

BEFORE YOU START

Things You Need To Know

Number of people required to assemble

Two people are required to assemble this item



Time to assemble



Guidelines

**FAILURE TO FOLLOW THESE WARNINGS
WHEN IN USE COULD RESULT IN INJURY**

DO



- We suggest you spend a short time reading through the leaflet before you start
- When you are ready to start. Make sure that you have the right tools. Plenty of Space and clean, dry area for assembly.
- Unwrap all packaging materials and place the components on a clean surface to protect it from damage, We recommend that the packaging is used to protect the surfaces during assembly.
- Carefully check that you have all the parts before beginning assembly.
- Due to the size of the product we recommend that it is assembled in the room intended for use.
- Ensure the product is fully assembled as illustrated and all fixings fully tightened before use.
- Wipe occasionally with a soft cloth slightly dampened with water. Then buff with a dry clean soft cloth.
- Wood will mellow and change color over time, we recommend that ornaments and items placed on the surface are moved regularly for the first few months to prevent uneven mellowing.
- Check all bolts and screws every 90 days. As necessary tighten if any are loose.
- Keep small parts and pieces away from children and pets until fully assembled.

DON'T



- Do not drag or pull your furniture.
- Do not rub or scrub the surface when cleaning.
- Do not use silicone based furniture polish. Silicone in furniture polishes can break down the finish.
- Never allow any kind of liquid to remain on your furniture. Absorption can cause wood to warp or finishes to de-laminate.
- Do not place hot items (e.g. hot drinks) directly on to the wood surface. Please make sure you use a placement or coaster.
- Do not stand on the item or use as a step ladder.

● **WARNING:DO NOT LET CHILDREN PLAY IN OR AROUND THE UNIT DUE TO THE POSSIBLE RISK OF INJURY.**

Queen Bed

Product Dimension

Actual product size
H51"(130cm) x W54"(163cm) x D84"(215cm)

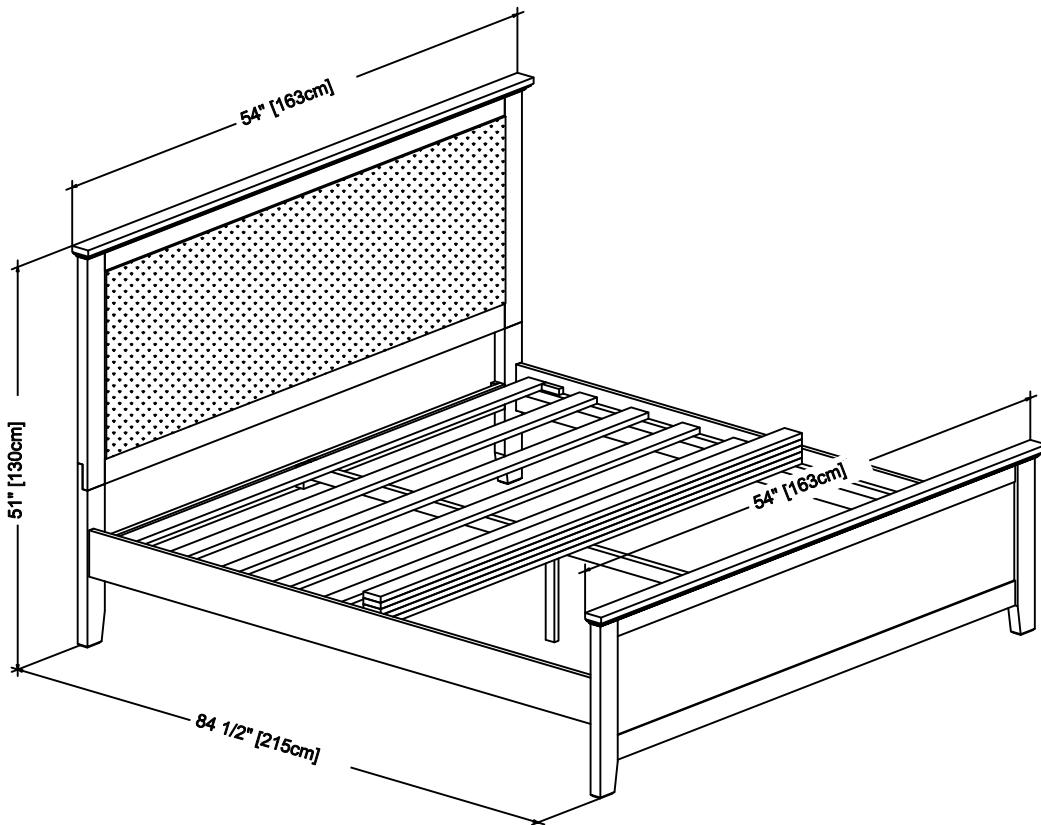

IMPORTANT-RETAIN FOR FUTURE REFERENCE

Should you prefer to speak with a customer service representative, you may call toll free.

Queen Bed

Things You Need To Know

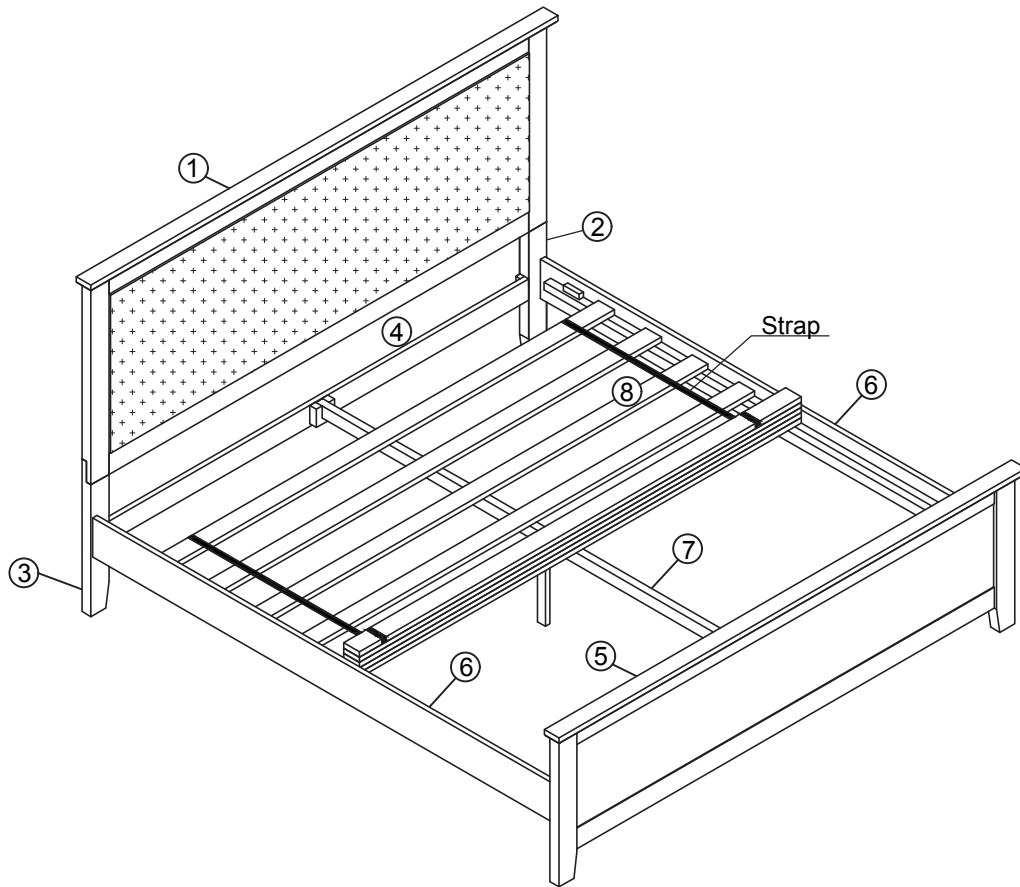

① Head Board x 1pc

⑤ Foot Board x 1pc

② Right Leg x 1pc

⑥ Side Rail x 2pcs

③ Left Leg x 1pc

⑦ Center Rail x 1set

④ Stretch Rail of Head Board x 1pc

⑧ Slats x 1set

Queen Bed

Things You Need To Know

**Components supplied. Please use this guide if you require replacement parts.
Fixtures and fittings supplied (not to scale)**



M8 x 35mm

Ⓐ Allen Bolt x 10pcs



Ⓑ Allen Key x 2pcs

Queen Bed

Assembly Instructions

1

STEP

1. Ensure all parts have been removed from the carton and place on a protected surface or carpet.

2. Check all parts and hardware are the same as the "Parts List".

3. Secure Right Leg (2) and Left Leg (3) to Stretch Rail (4) with Allen Bolt (A) by using Allen Key (B).

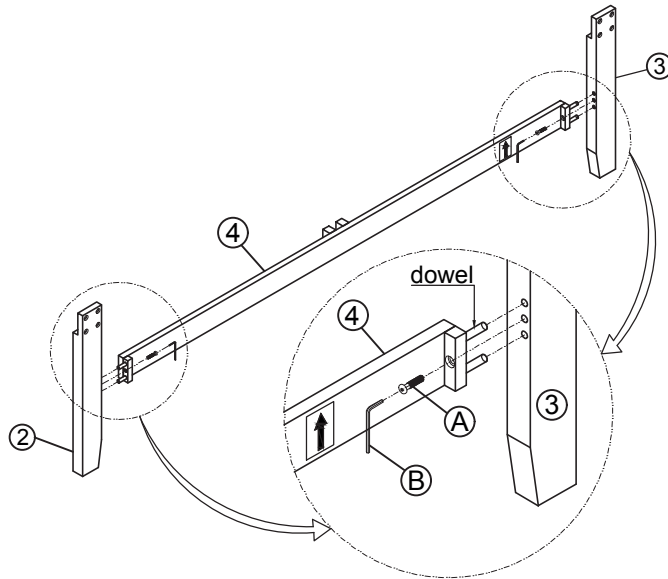

2

STEP

1. Secure the assembled Right Leg (2), Left Leg (3) and Stretch Rail (4) to Head Board (1) with Allen Bolt (A) by using Allen Key (B).

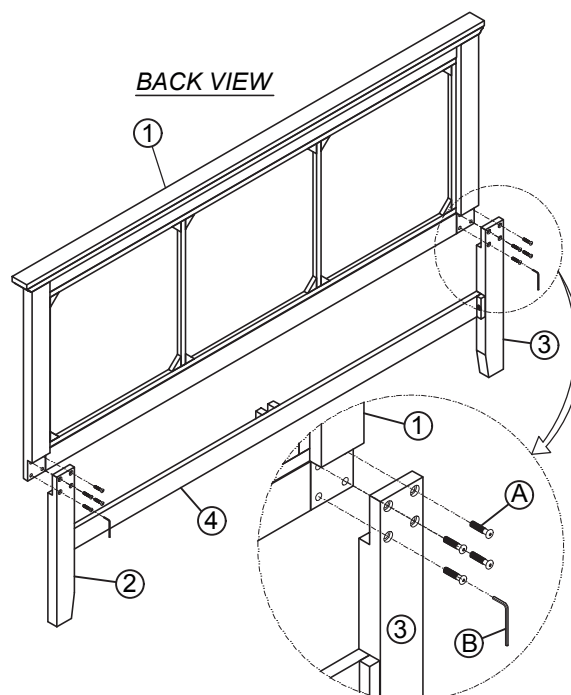

Queen Bed

Assembly Instructions

3

STEP

1. Secure Side Rails (6) to Head Board (1) and Foot Board (5) by inserting the hook hardware to the Bolts attached in the Head Board (1) and Foot Board (5) by using Allen Key (B) to tighten all Bolts.

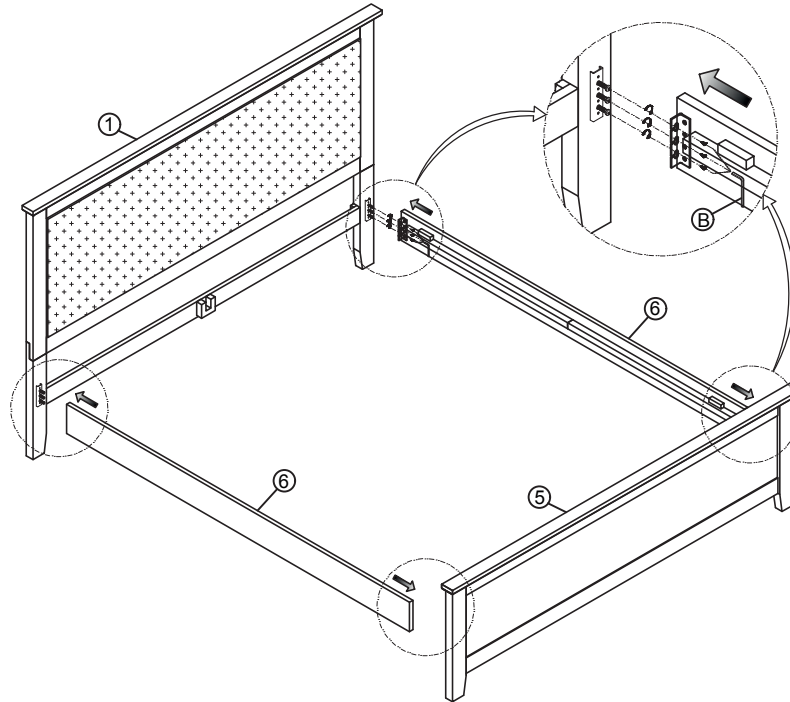

4

STEP

1. The Center Rail (7) set is already assembled. Just rotate and lock the dowel, then tighten the bolt.

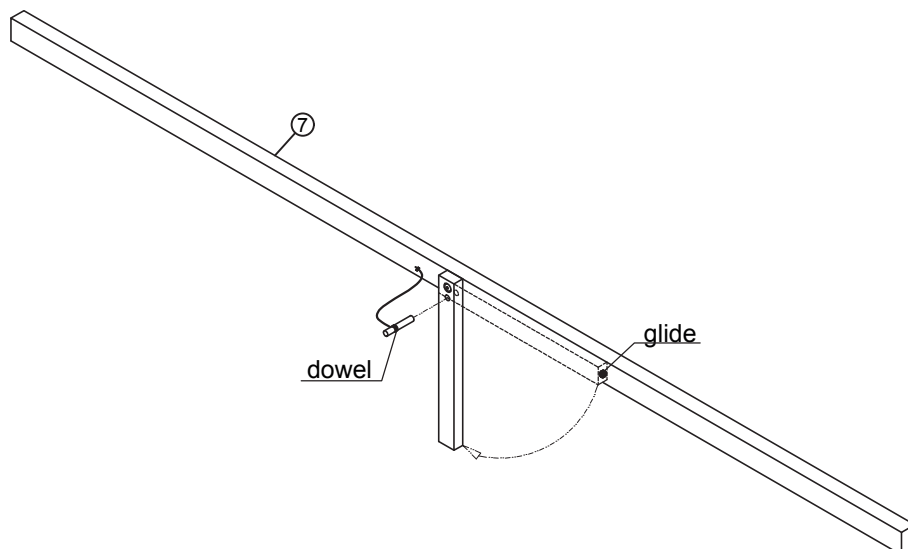

Queen Bed

Assembly Instructions

5
STEP

1. Attach the assembled Center Rail (7) set to Head Board (1) and Foot Board (5).

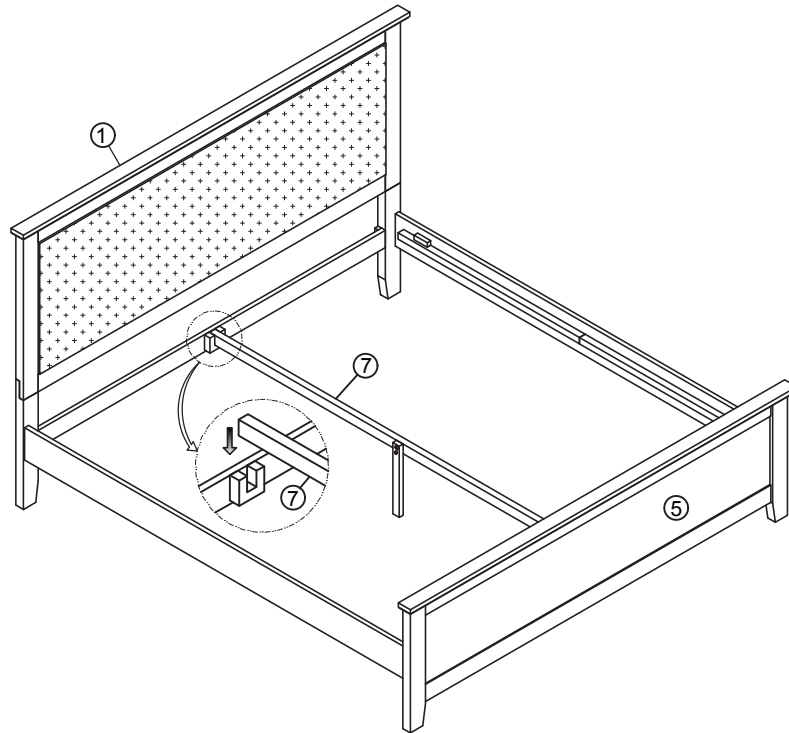

6
STEP

1. Place the remaining Slats (8) on the bed to complete the assembly.

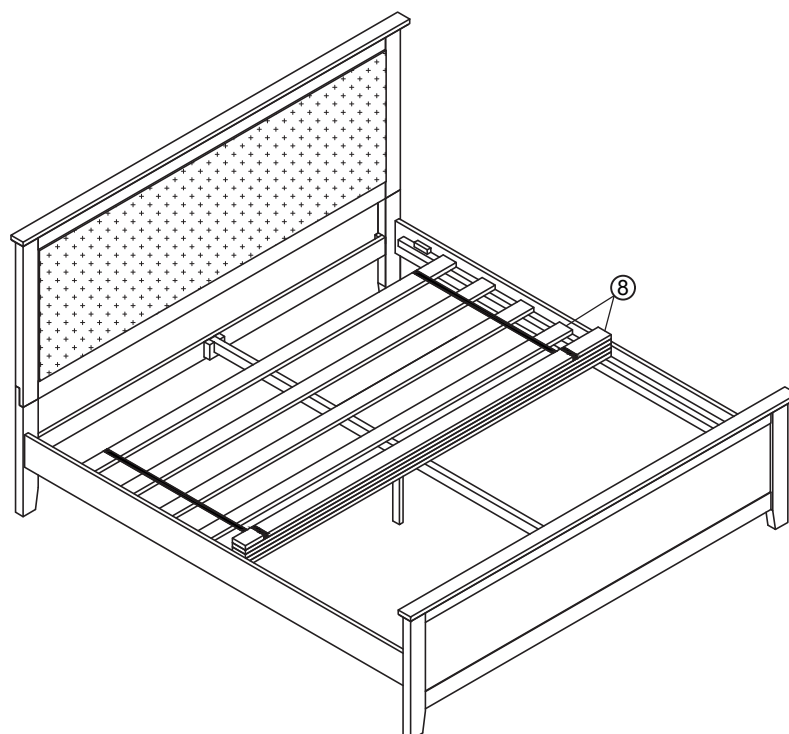

Limited Warranty

The product you have purchased is warranted against defects in material and workmanship while owned by the “Original Purchaser”. The term “Original Purchaser” is defined as that party or entity which purchases these products from an authorized dealer or retailer as shown by the original sales receipt. This warranty does not apply to “as is” or previously owned products.

The manufacturer warrants its products to be free from defects in materials and workmanship (normal wear and tear, fading and stretching excepted), for one year from the date of purchase, except as provided below under the limited warranty.

This warranty gives you specific rights, and you may also have other rights, which vary from state to state (or country to country). All warranties are limited to the Original Purchaser for normal use.

The exceptions or exclusions to this warranty are:

- Upholstery material and foam cushion material is warranted against defects in material and workmanship for a period of one year, beginning on the date of purchase as shown on the original sales receipt.
- Any warranty claim that is submitted after the limited warranty period, or without proper proof of purchase will not include the cost of parts, labor, or delivery on the warranted parts within a reasonable amount of time. We reserve the right to require damaged parts to be returned to us upon request. Natural markings such as scars, brands, grain variations, wrinkles, color variations, etc. will be considered normal characteristics and not construed as defects.
- For claims or questions concerning this warranty, please contact the Customer Service Department on the web. Be prepared to provide your name, address, daytime phone number, the model and purchase order number of the product, date of purchase, and the store where it was purchased. The manufacturer requires that the original sales receipt be submitted with all requests to confirm that you are the Original Purchaser according to our written warranty.