

ASSEMBLY INSTRUCTIONS.

ACCENT TABLE OAK

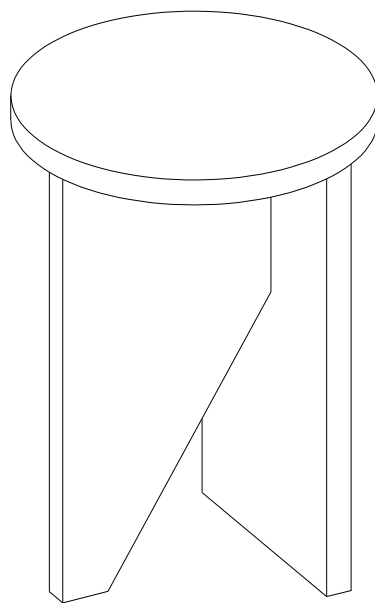

THANK YOU FOR YOUR PURCHASE!

PARTS LIST

A. Top = 1

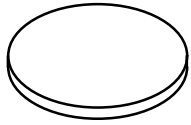

B. Leg I = 1

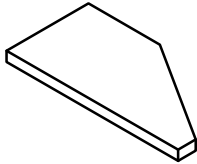

C. Leg II = 1

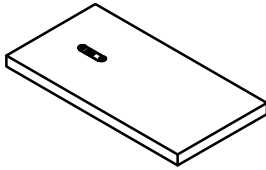

HARDWARE LIST

1. Bolt
M6x25 = 8

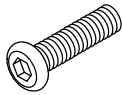

2. Spring Washer
M6.5x11 = 4



3. Flat Washer
M6.5x16 = 4



4. Allen key
M4 = 1



5. Pat = 1

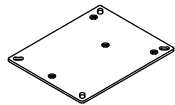

Step 1

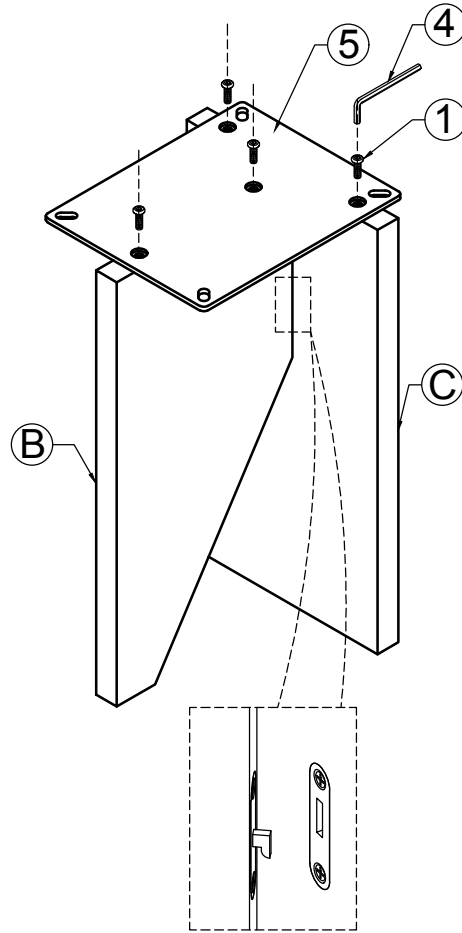

Step 2

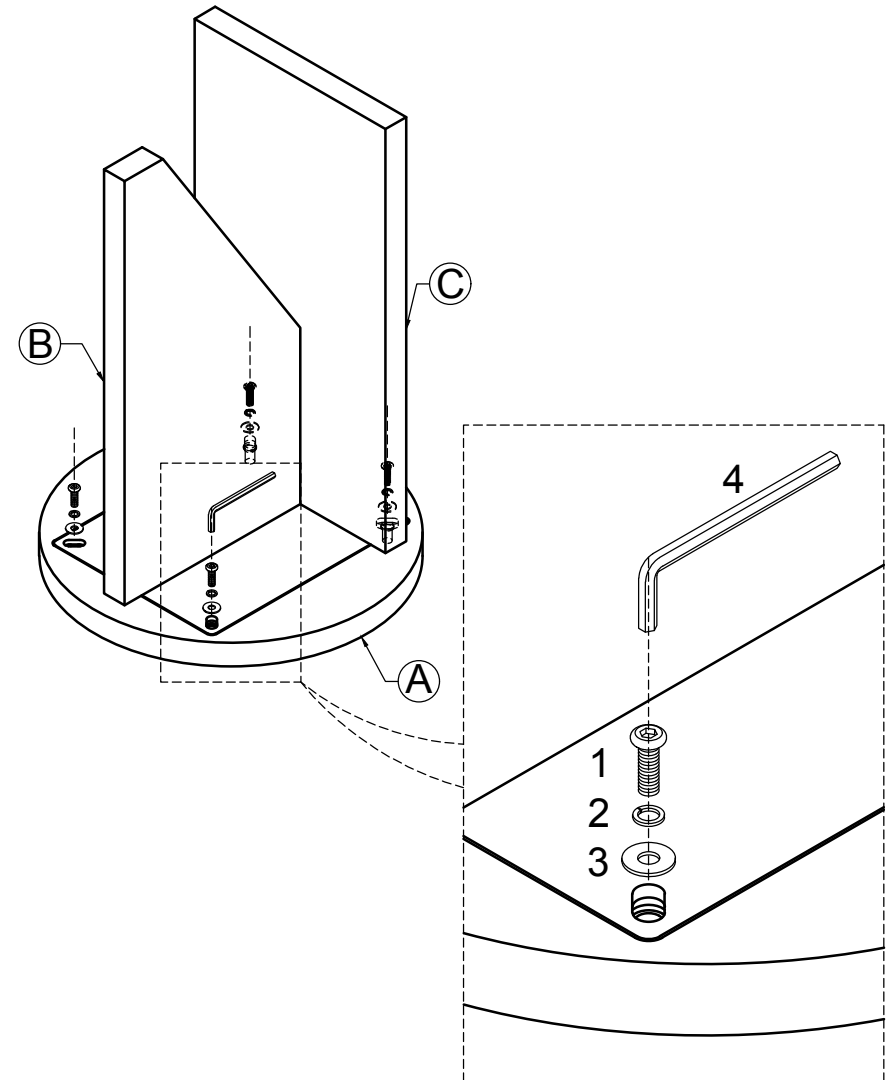

NOTES.

Thank you for purchasing this quality product! Be sure to check all packing material carefully for small part that may have come loose inside the carton during shipping.