

Computer Desk

User Manual

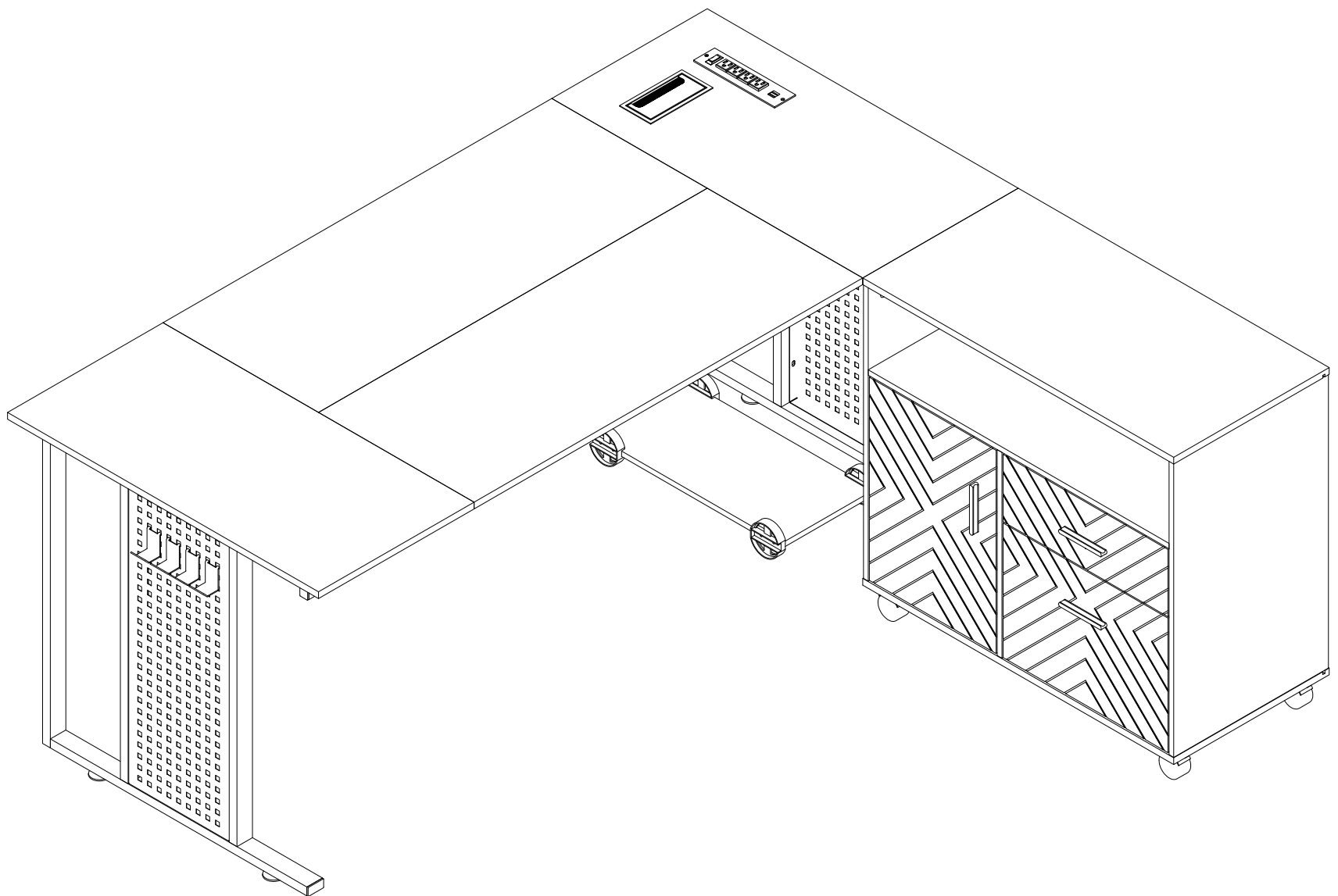

Installation takes  x 2~4hour

 Please read this instruction manual carefully before using the product

Package Contents

Plates and
iron components

Assembly tool kit

Instruction manual

⚠ Precautions

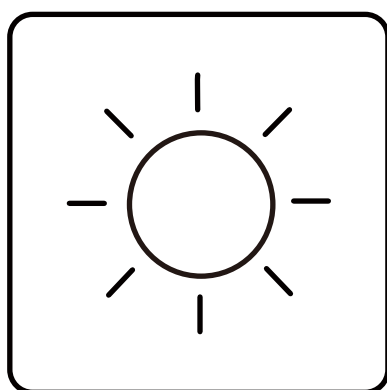

1. Avoid extended periods of direct sunlight exposure.

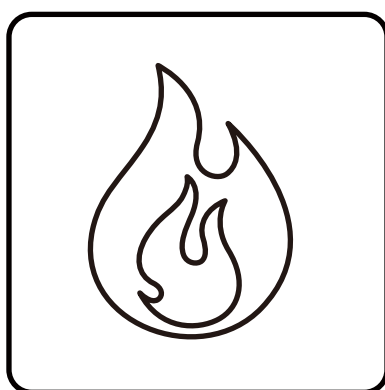

2. Stay away from fire.

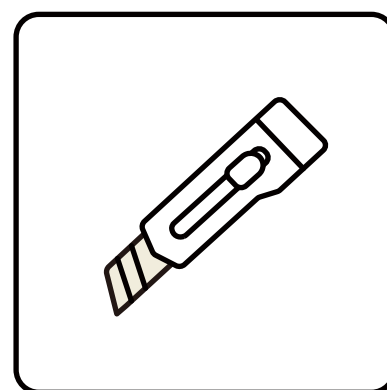

3. Keep away from sharp objects.

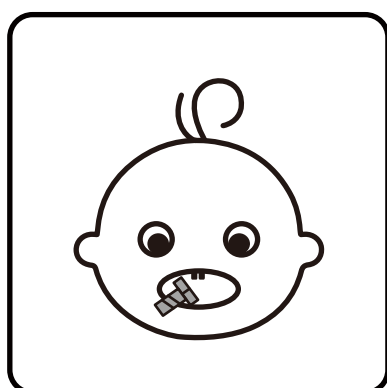

4. Keep infants and children away from assembly parts to avoid choking and suffocation.



5. Keep away from corrosive substances.

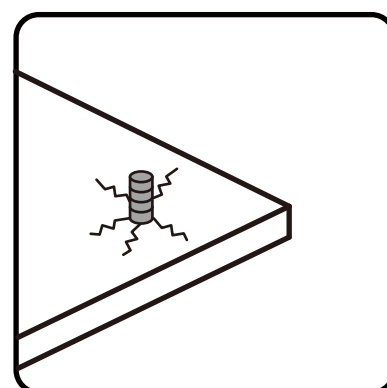

6. Pay attention to avoid over-tightening fasteners, as they may cause cracking within the board.

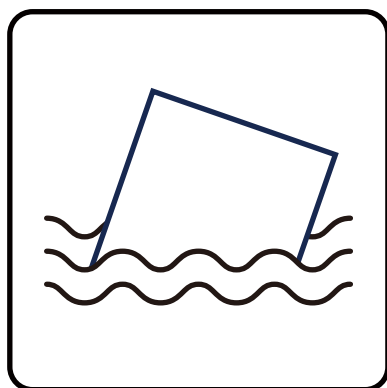

7. Prevent objects from being damaged by immersion in water.

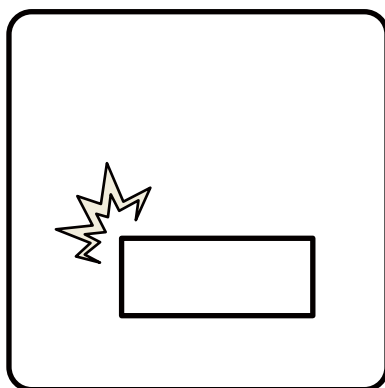

8. Prevent object collision and damage.

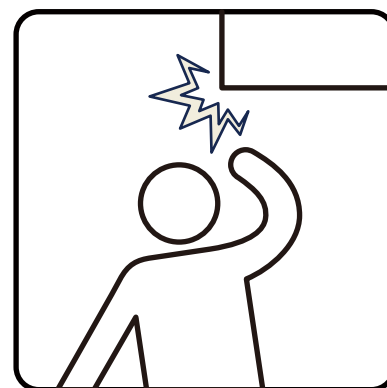

9. Be careful to avoid collisions.

⚠ Installation of Cams and Pins

Be sure to use the proper screws to avoid damaging the parts

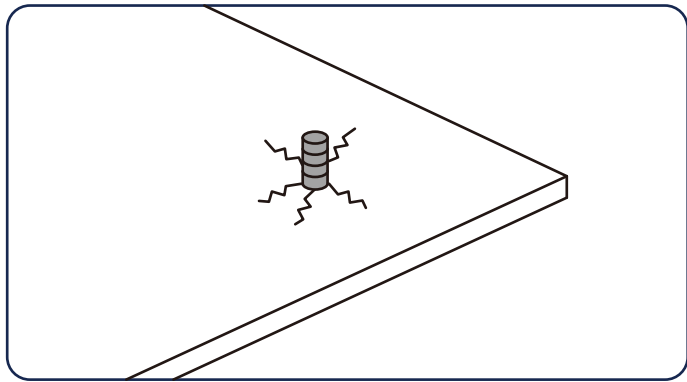
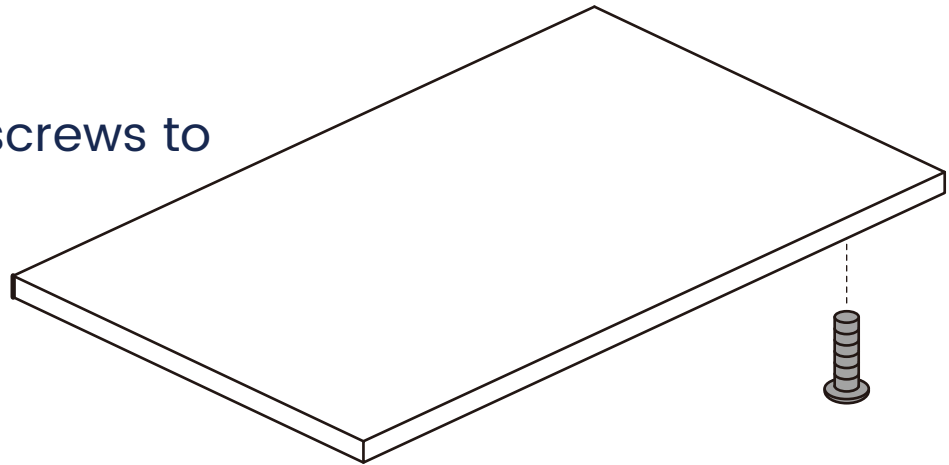

Wrong screws can cause the plank to crack

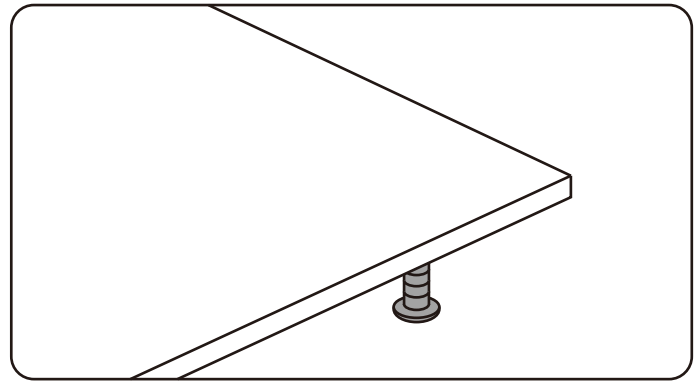

The right screw is the right size

⚠ Matters needing attention

1. When installing the screws in the installation step, the screws do not need to be tightened.

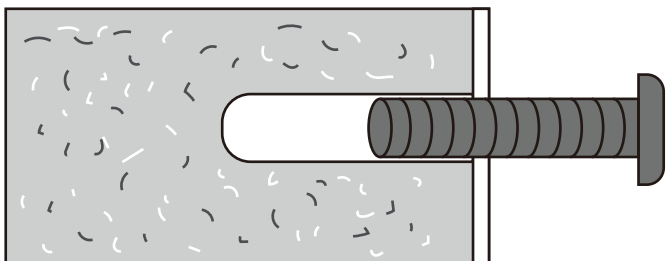

2. After this installation step is confirmed and the holes are aligned, then tighten all the screws.

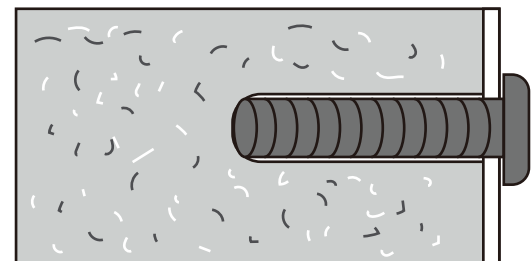

3. If the screws are tightened during the installation process, it will cause problems such as misalignment of the screw holes and misalignment of the board in subsequent installations

Disassembly Diagram

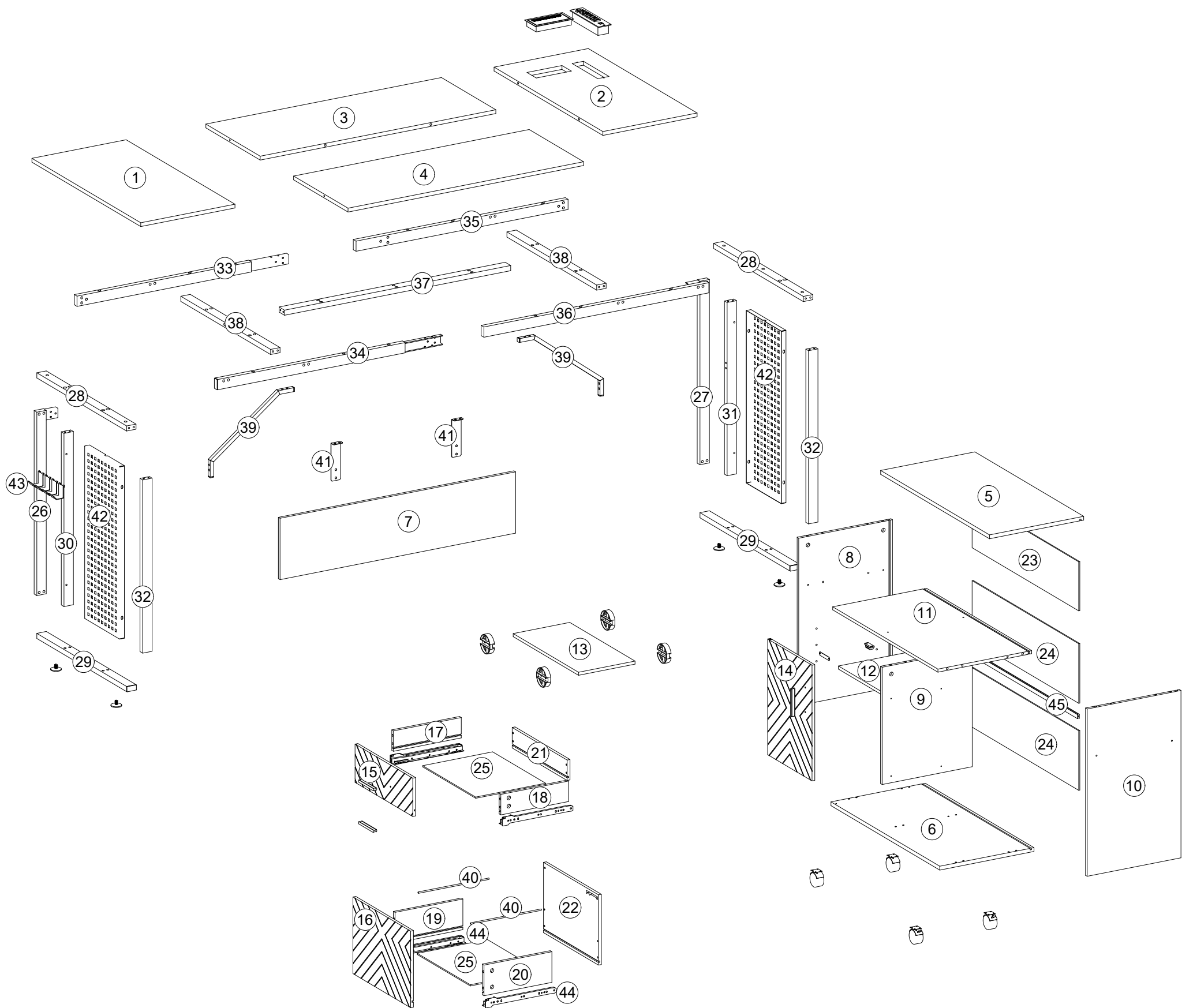

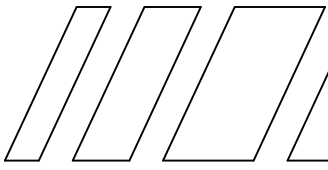

8

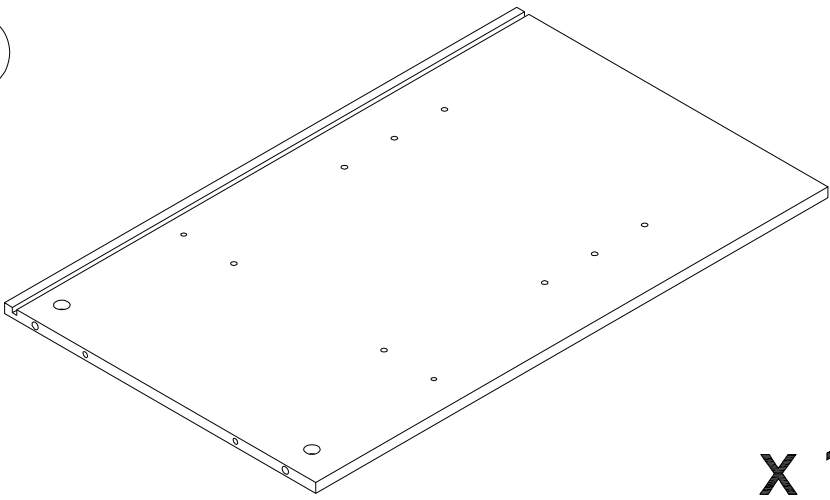

x 1

10

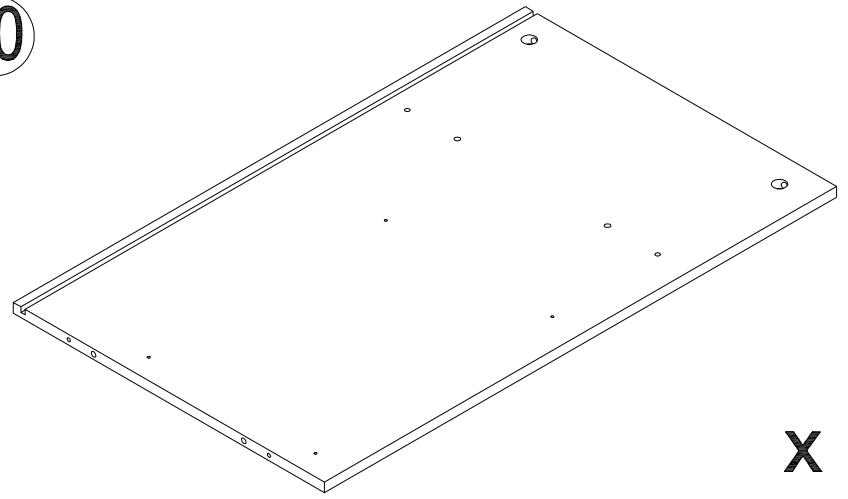

x 1

12

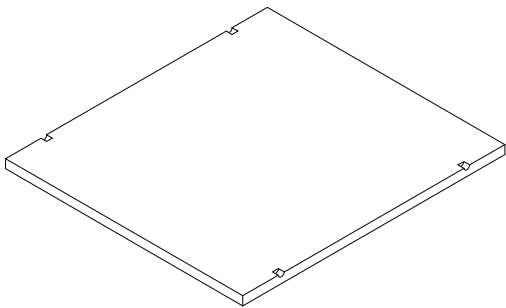

x 1

14

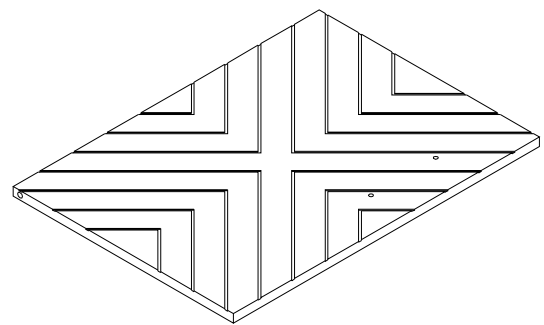

x 1

16

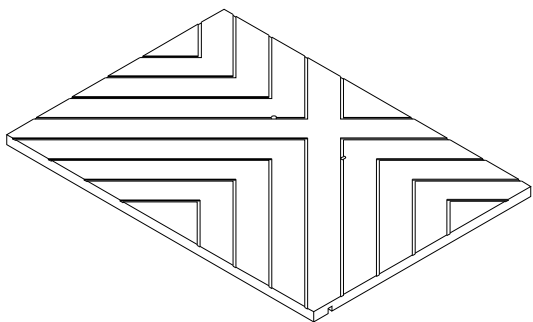

x 1

17

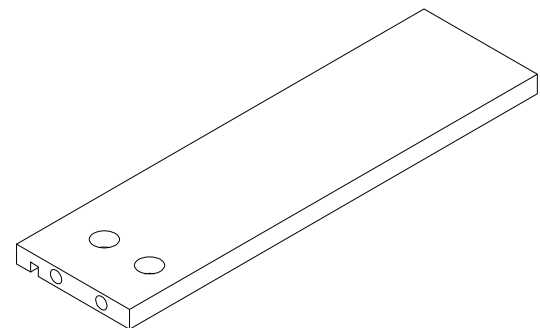

x 1

18

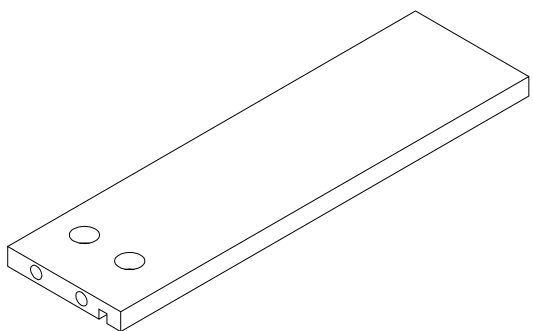

x 1

21

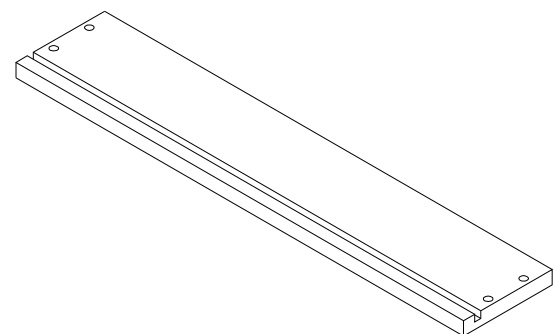

x 1

28

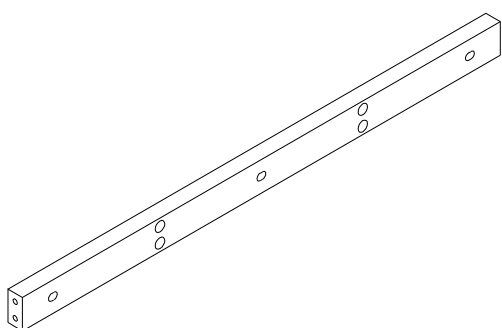

x 2

29

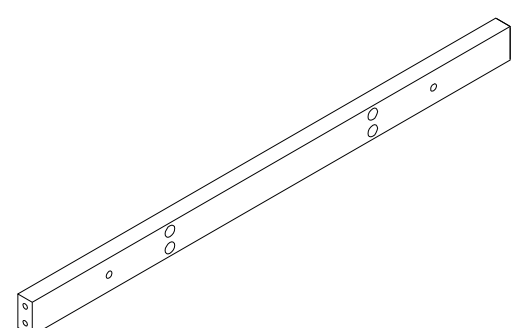

x 2

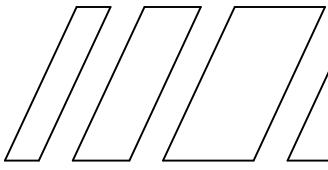

Package A

P 5

30

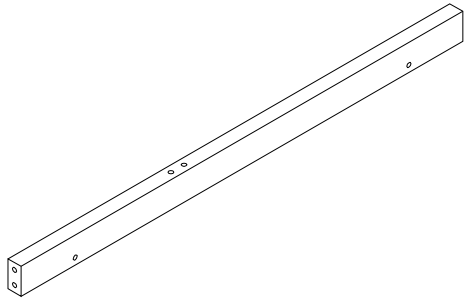

x 1

31

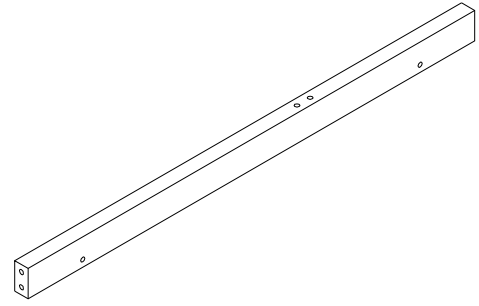

x 1

32

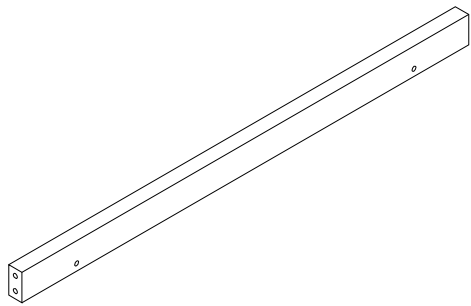

x 2

38

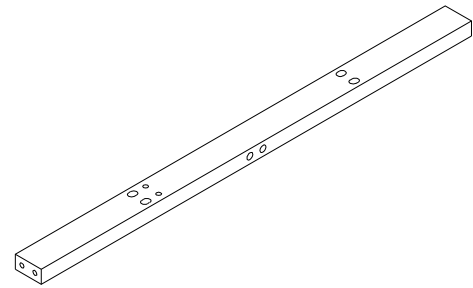

x 2

39

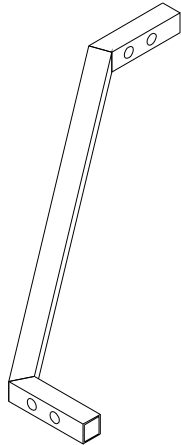

x 2

42

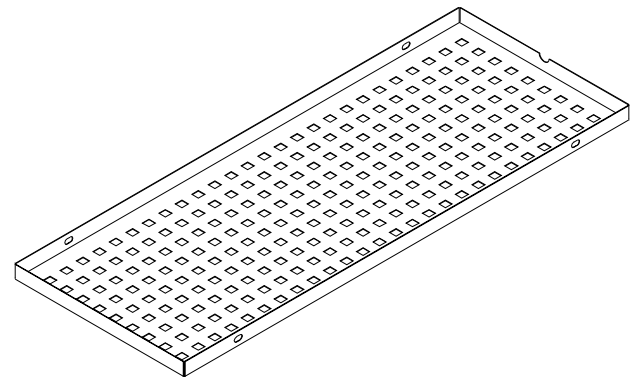

x 2

44

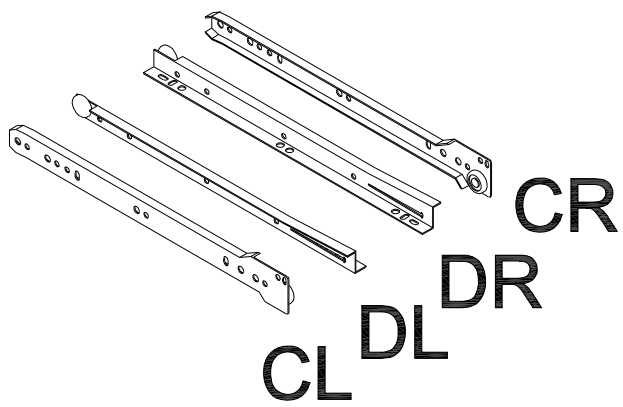

x 2

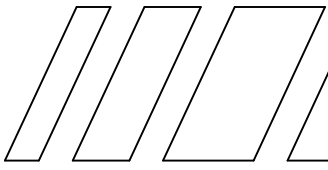

Package B

P 6

1

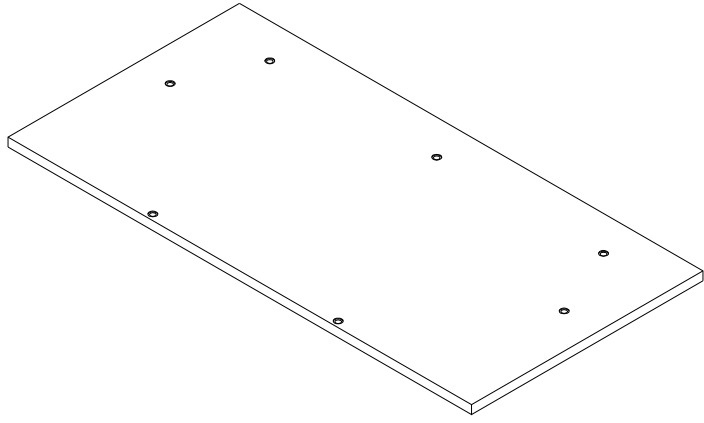

x 1

2

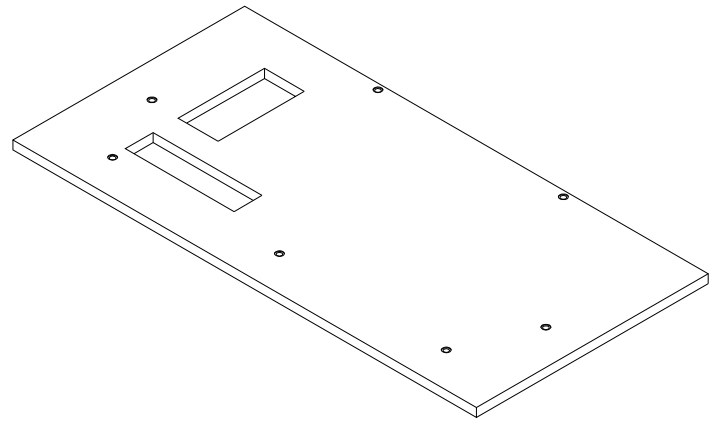

x 1

3

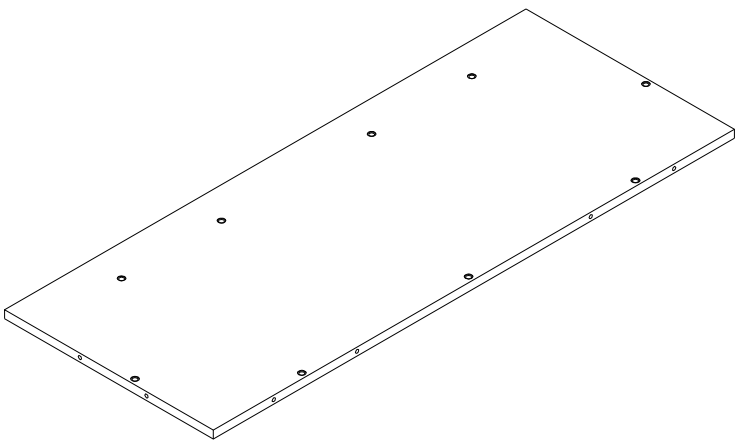

x 1

4

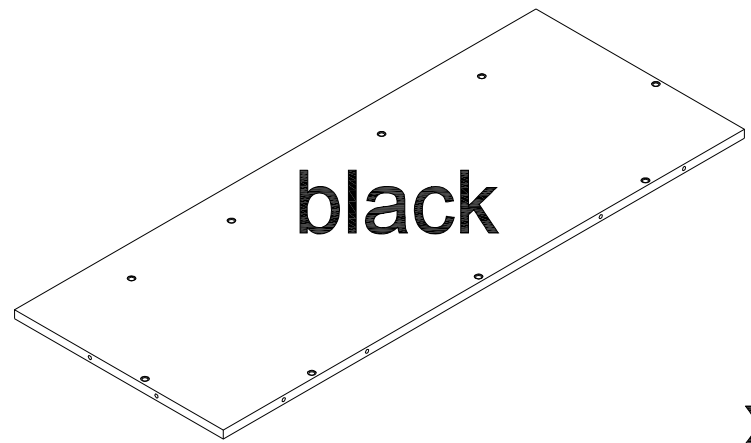

x 1

5

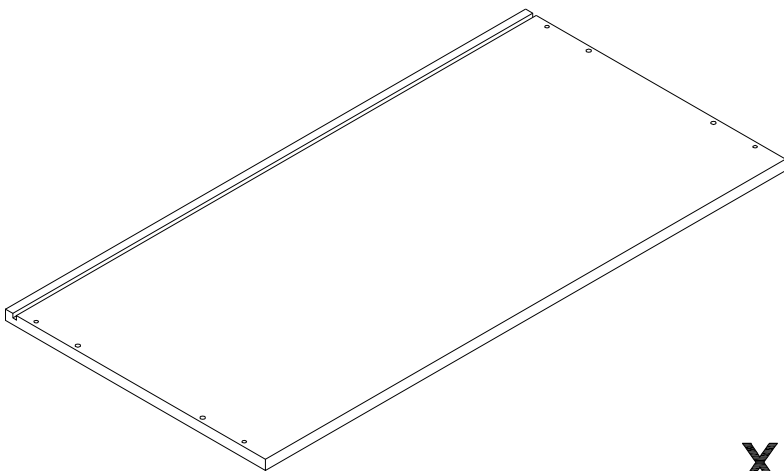

x 1

6

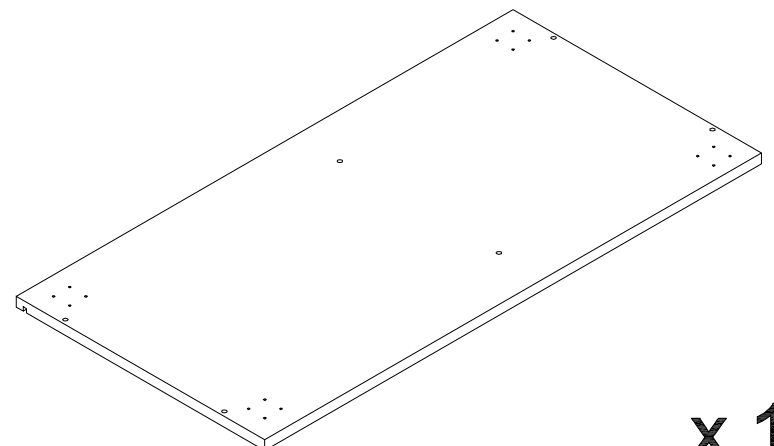

x 1

7

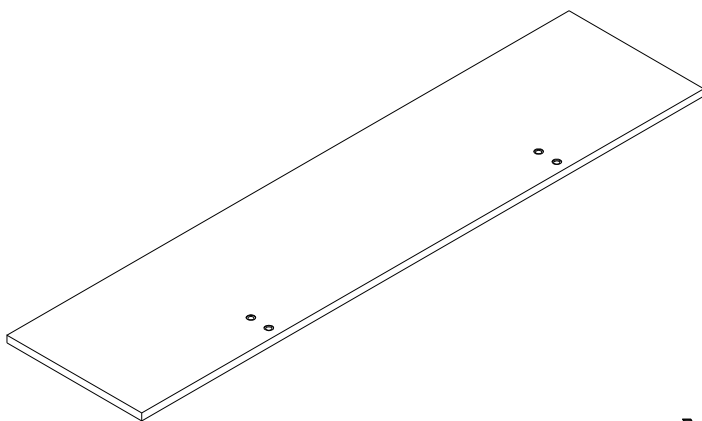

x 1

9

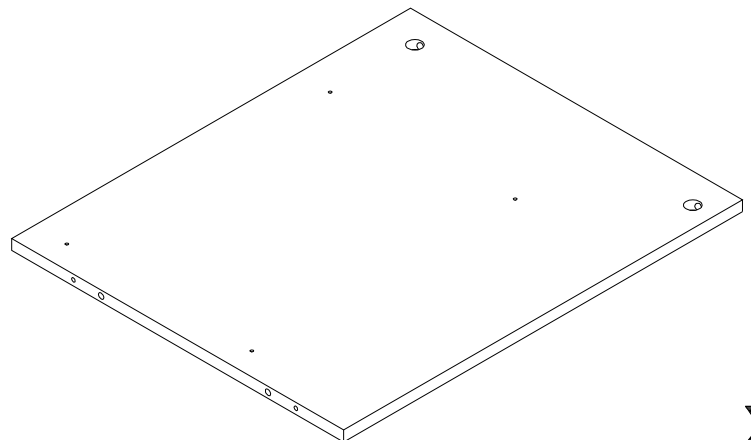

x 1

11

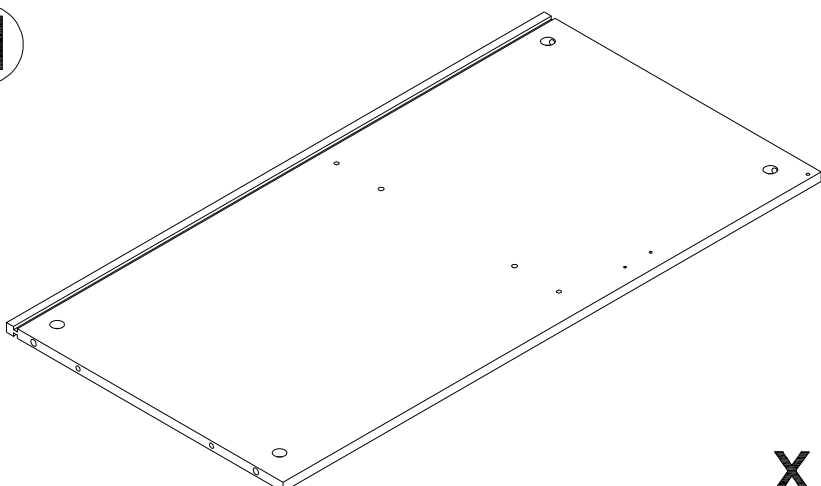

x 1

13

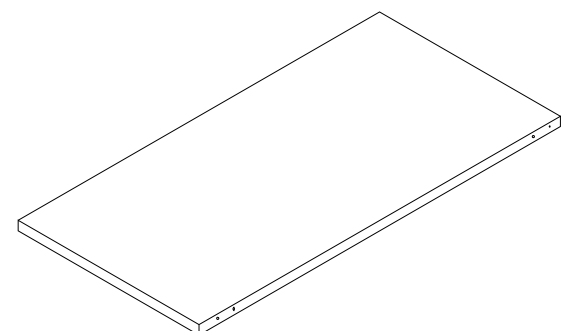

x 1

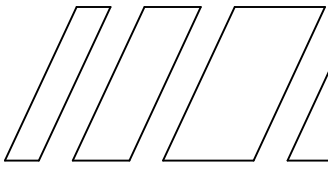

15

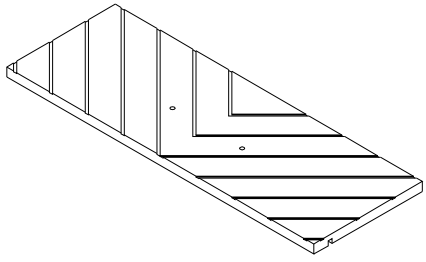

x 1

19

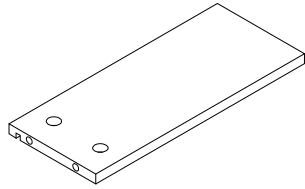

x 1

20

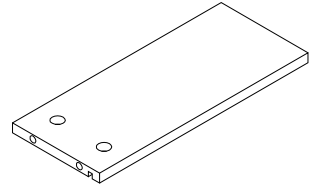

x 1

22

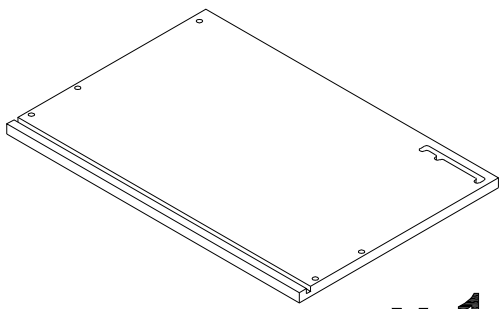

x 1

23

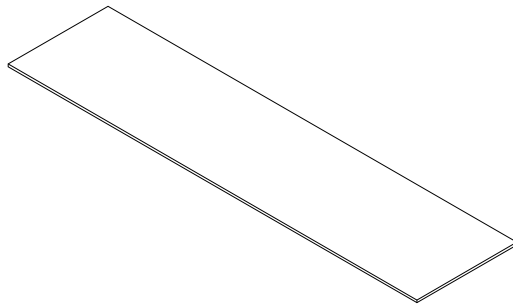

x 1

24

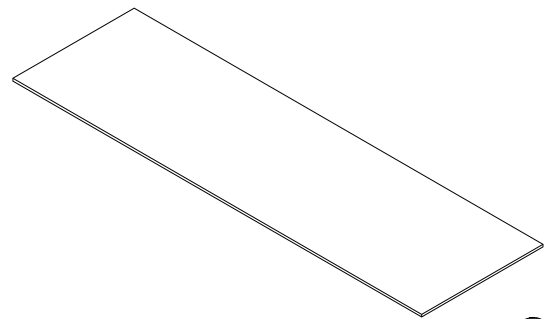

x 2

25

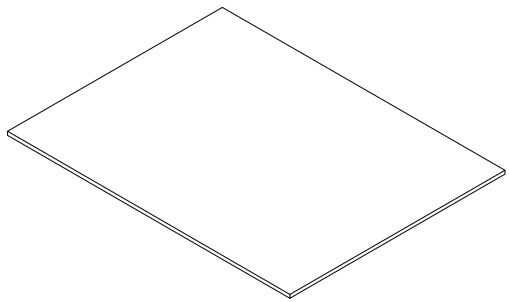

x 2

26

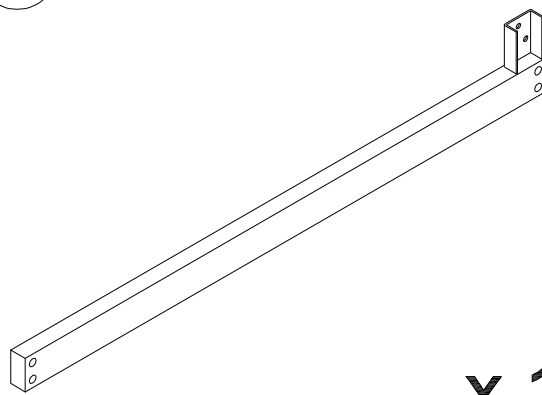

x 1

27

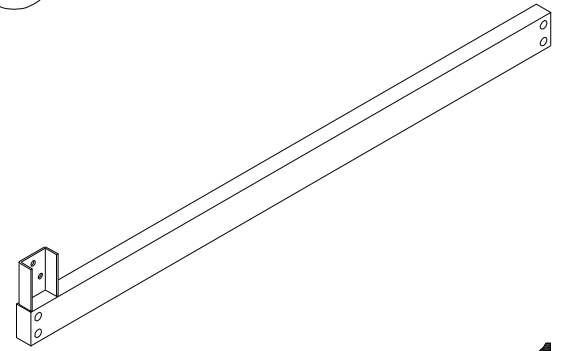

x 1

33

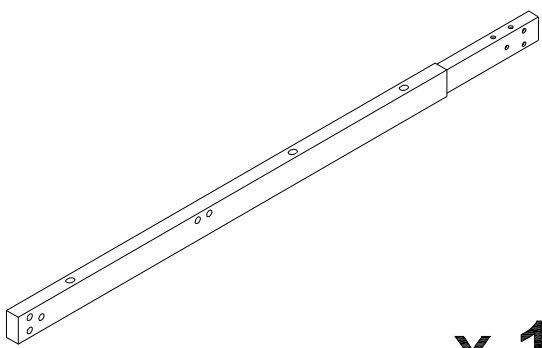

x 1

34

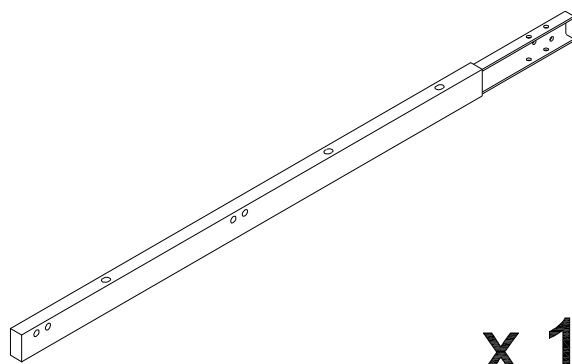

x 1

35

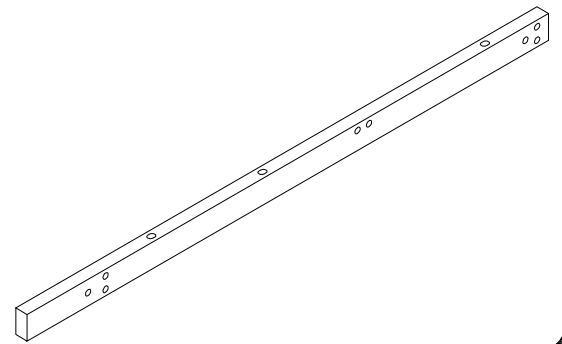

x 1

36

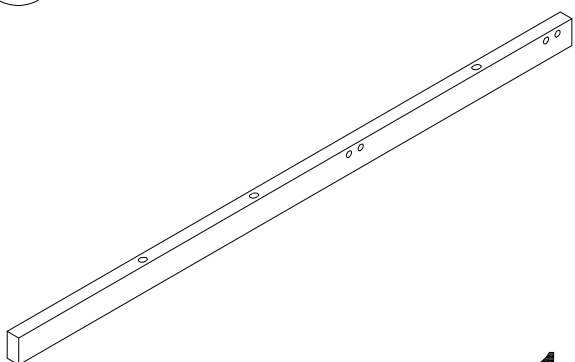

x 1



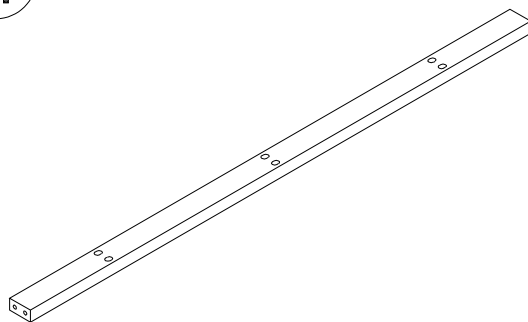







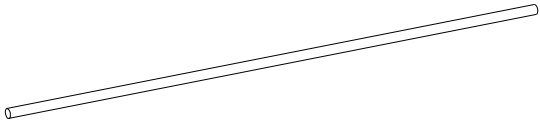
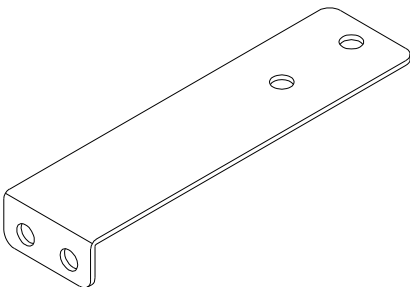
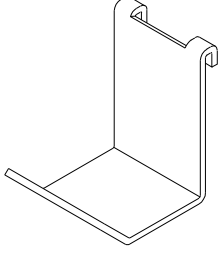
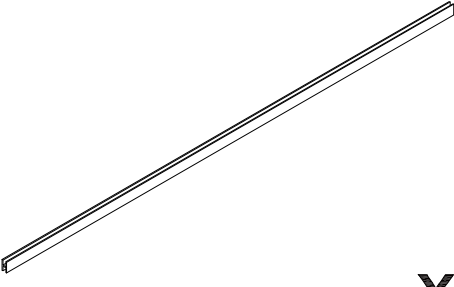







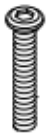



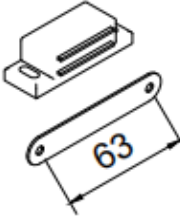

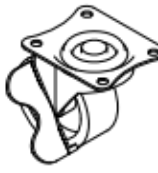
37

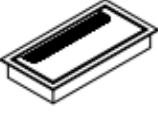

x 1

Package B

P 8

 40 x 2		 41 x 2		 43 x 4			
 45 x 1							
A M5X42  18 PCS	B Ø15x10  18 PCS	C Ø6x40  28 PCS	D M3.5X12  28 PCS	E M5X40  14 PCS	F M4X16  6 PCS	G M6X10  32 PCS	H M6X40  36 PCS
J M6X60  4 PCS	K M6X30  28 PCS	L M3.5X14  30PCS	M M6X50  12 PCS	N  1 PCS	P  2 PCS	Q  2 PCS	R  12 PCS
S  4 PCS	T  2 PCS	U 063-96  3 PCS	V A200 M8  4 PCS	W  4 PCS	Y  1 PCS	Z  1 PCS	
4#  1 PCS	3#  1 PCS	 1 PCS					

All the screws
are in "Package B"

1

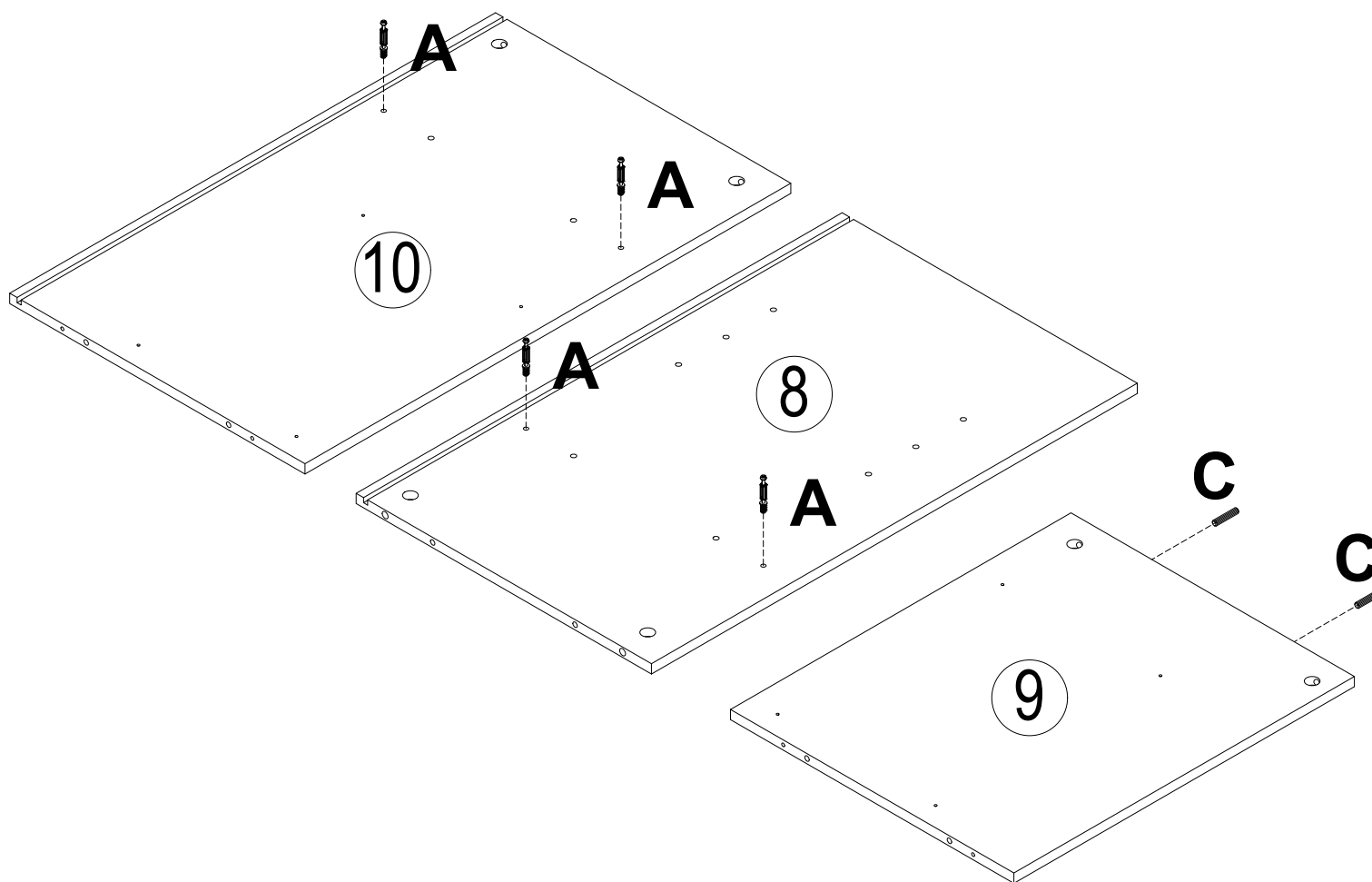
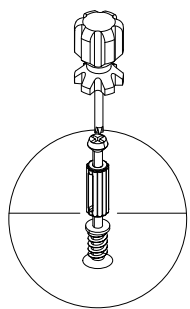

A M5X42



4 PCS

C Ø6x40



2 PCS

2

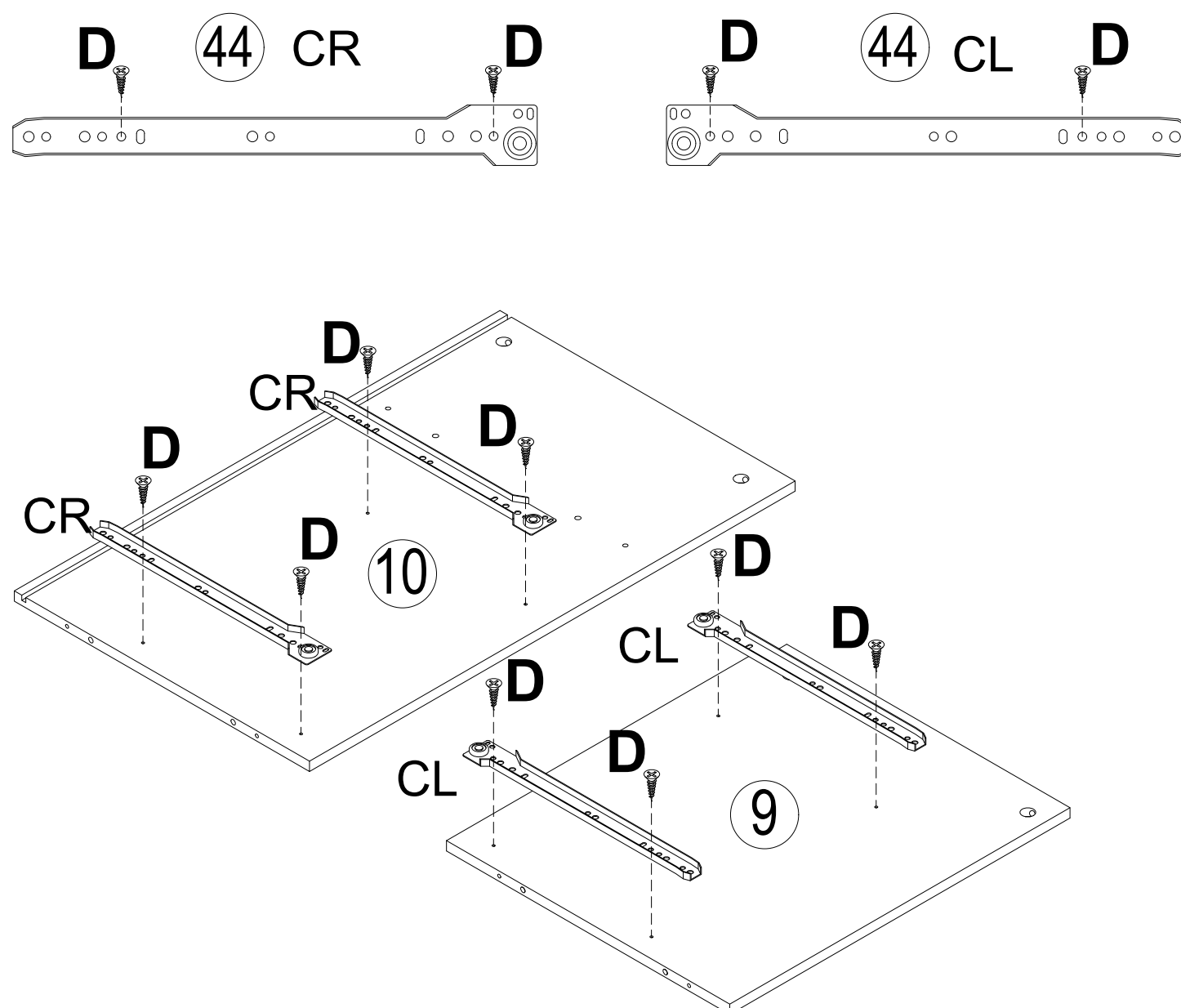
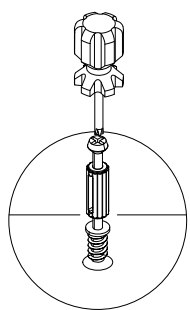

D M3.5X12



8 PCS

3

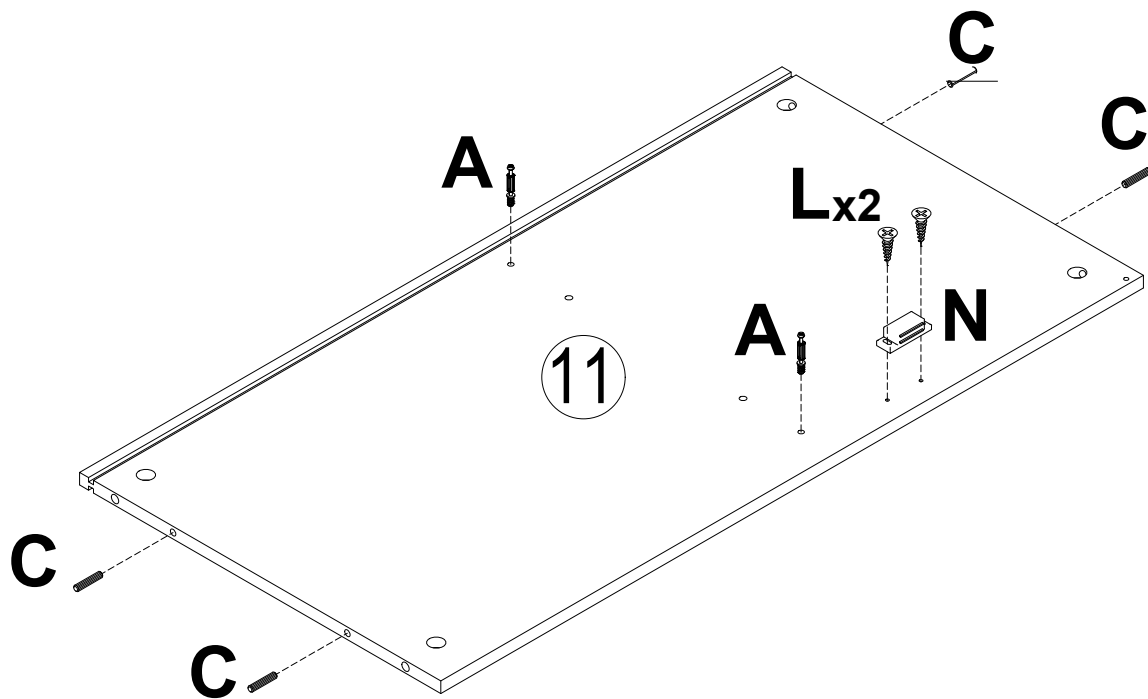
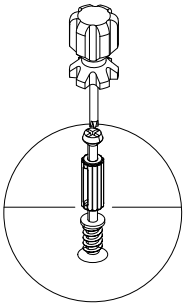

N

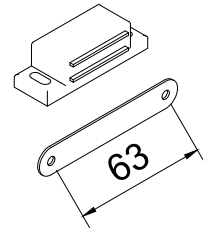

1 PCS

A M5X42

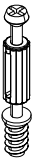

2 PCS

C Ø6x40



4 PCS

L M3.5X14



2PCS

4

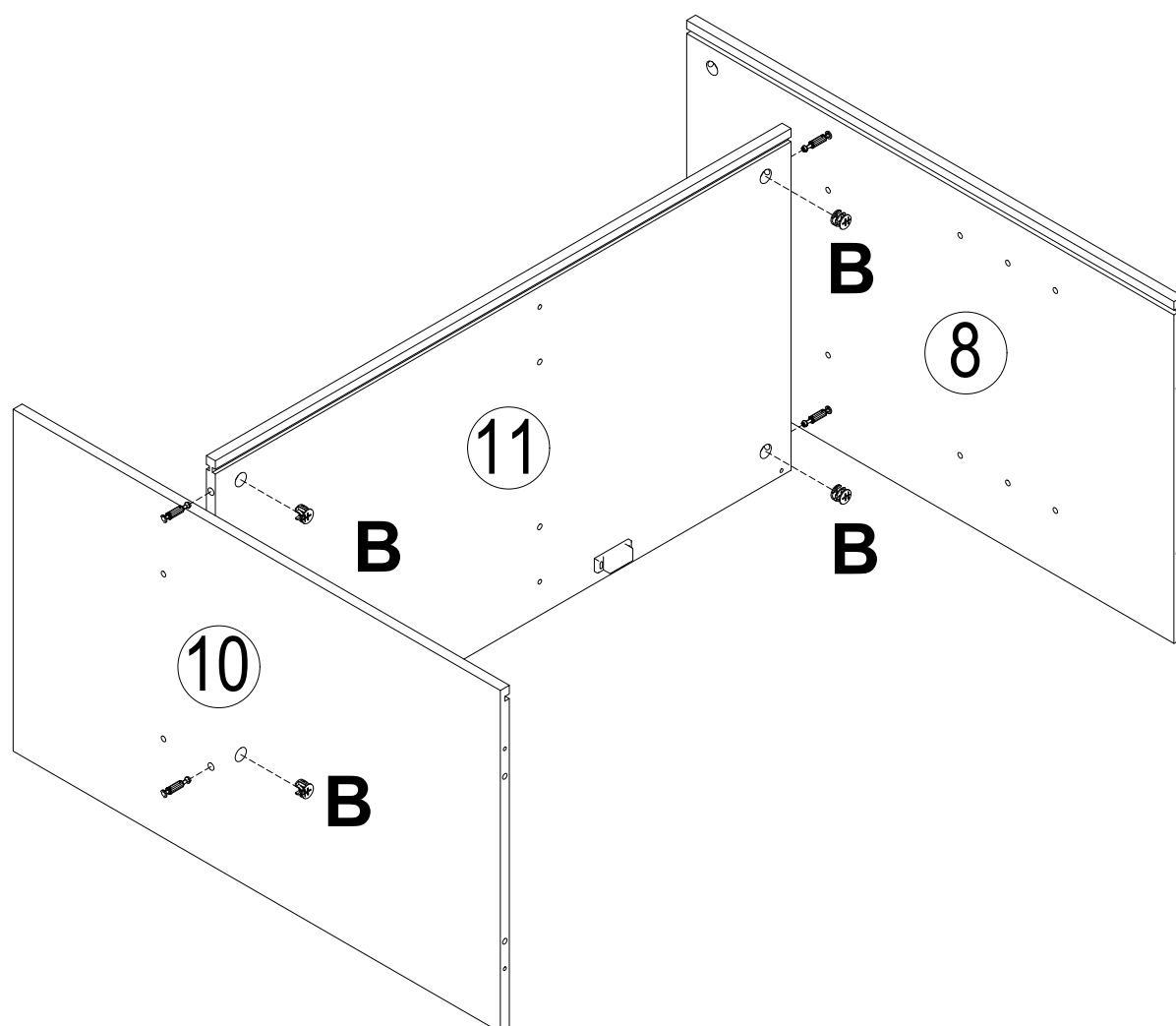
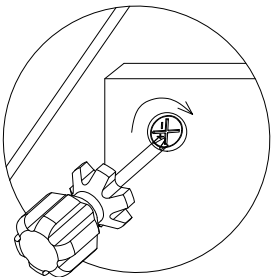
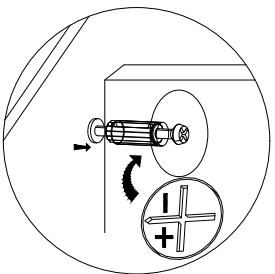

B Ø15x10

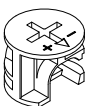

4 PCS

5

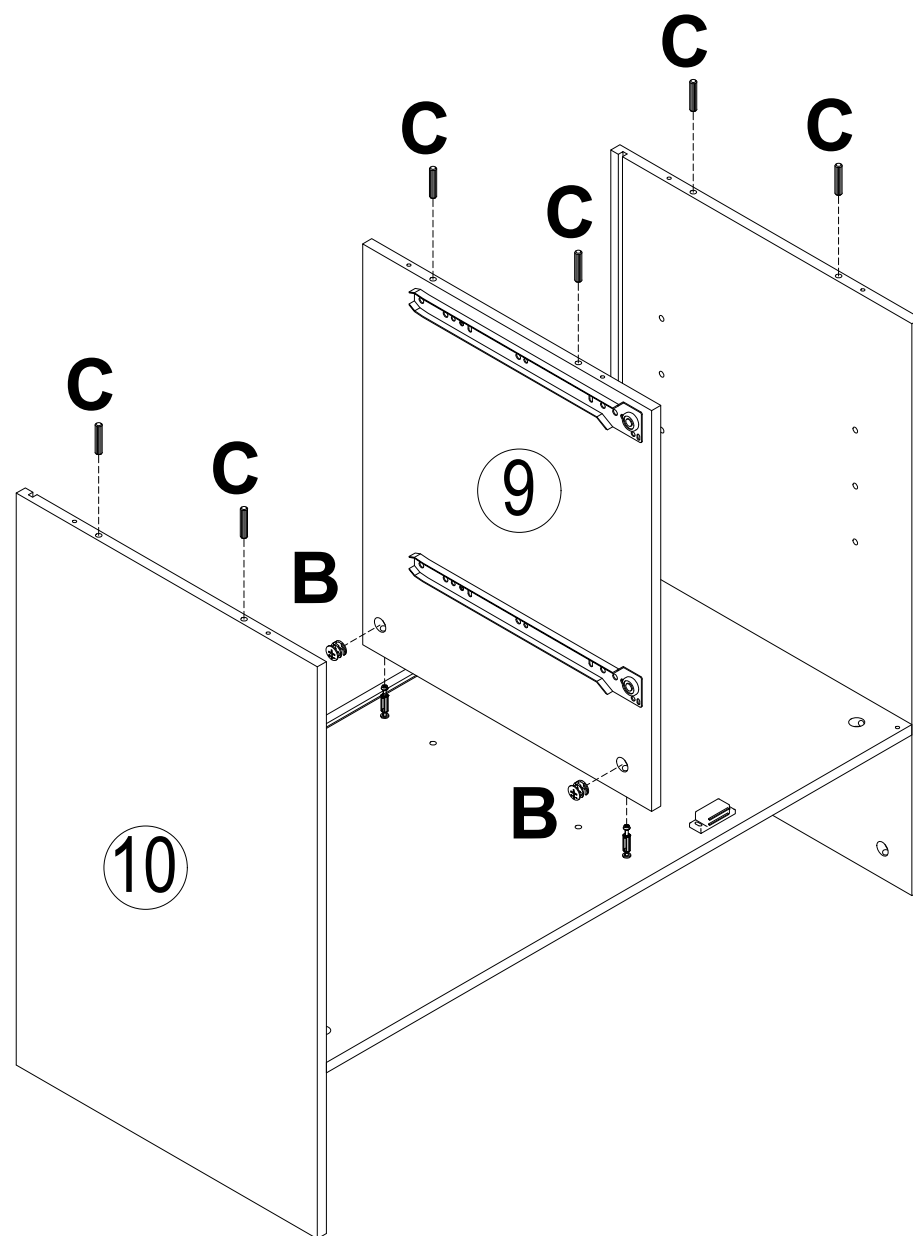
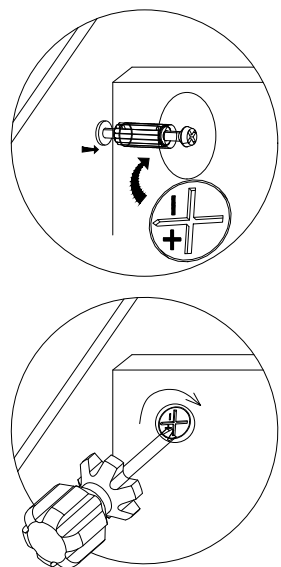

B Ø15x10

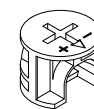

2 PCS

C Ø6x40



6 PCS

6

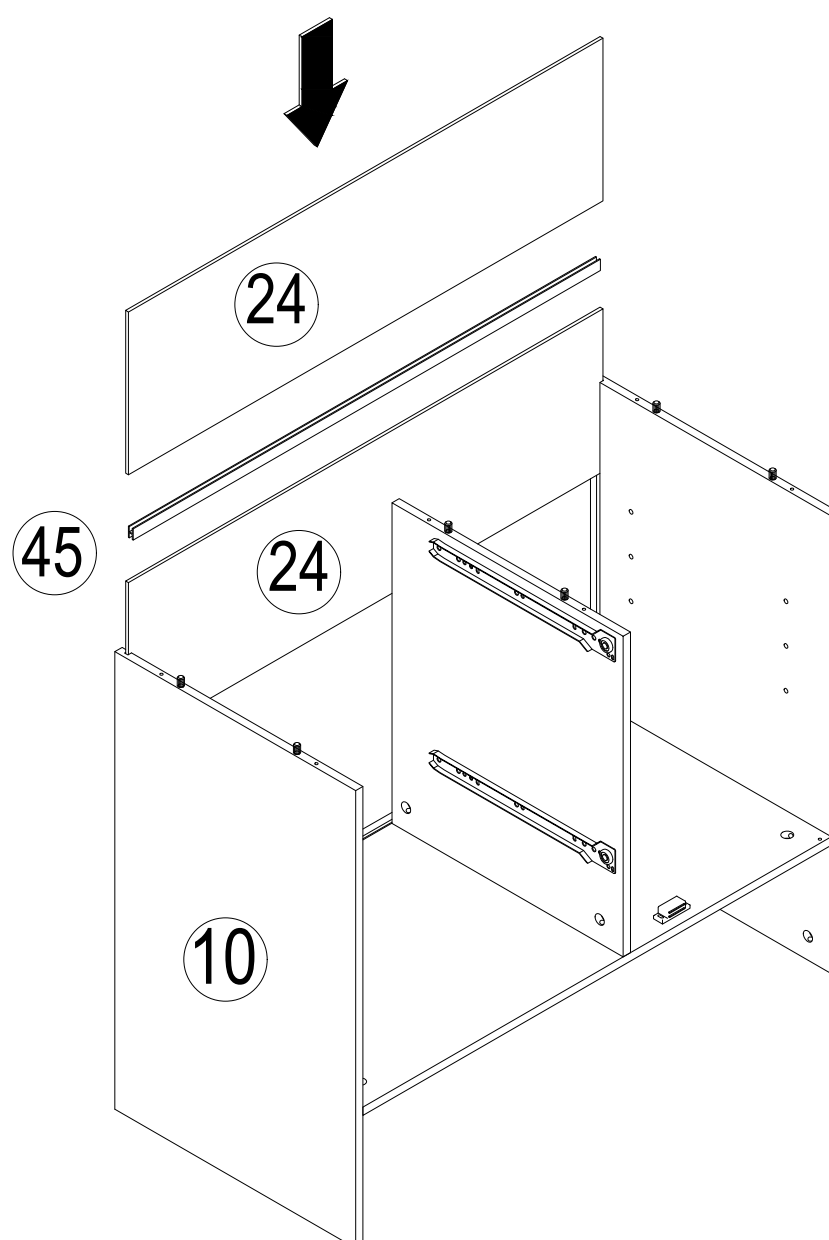

7

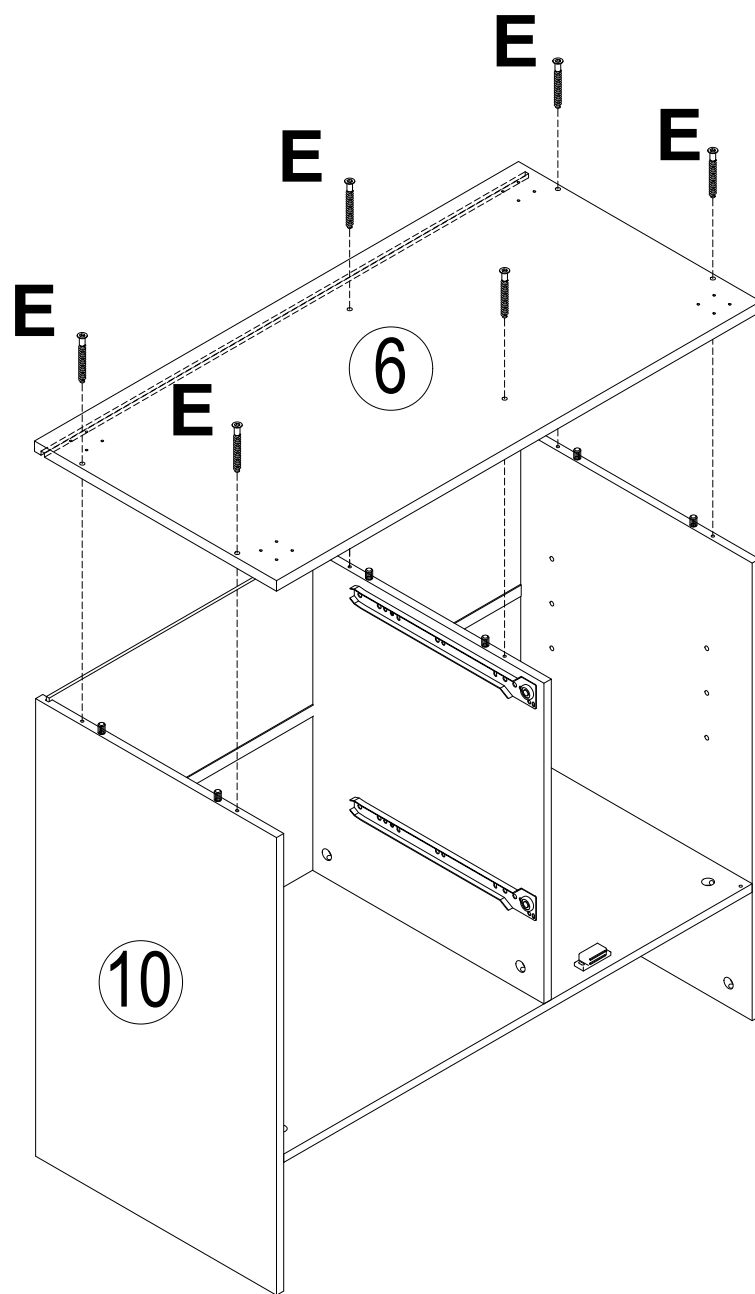

E M5X40



6 PCS

8

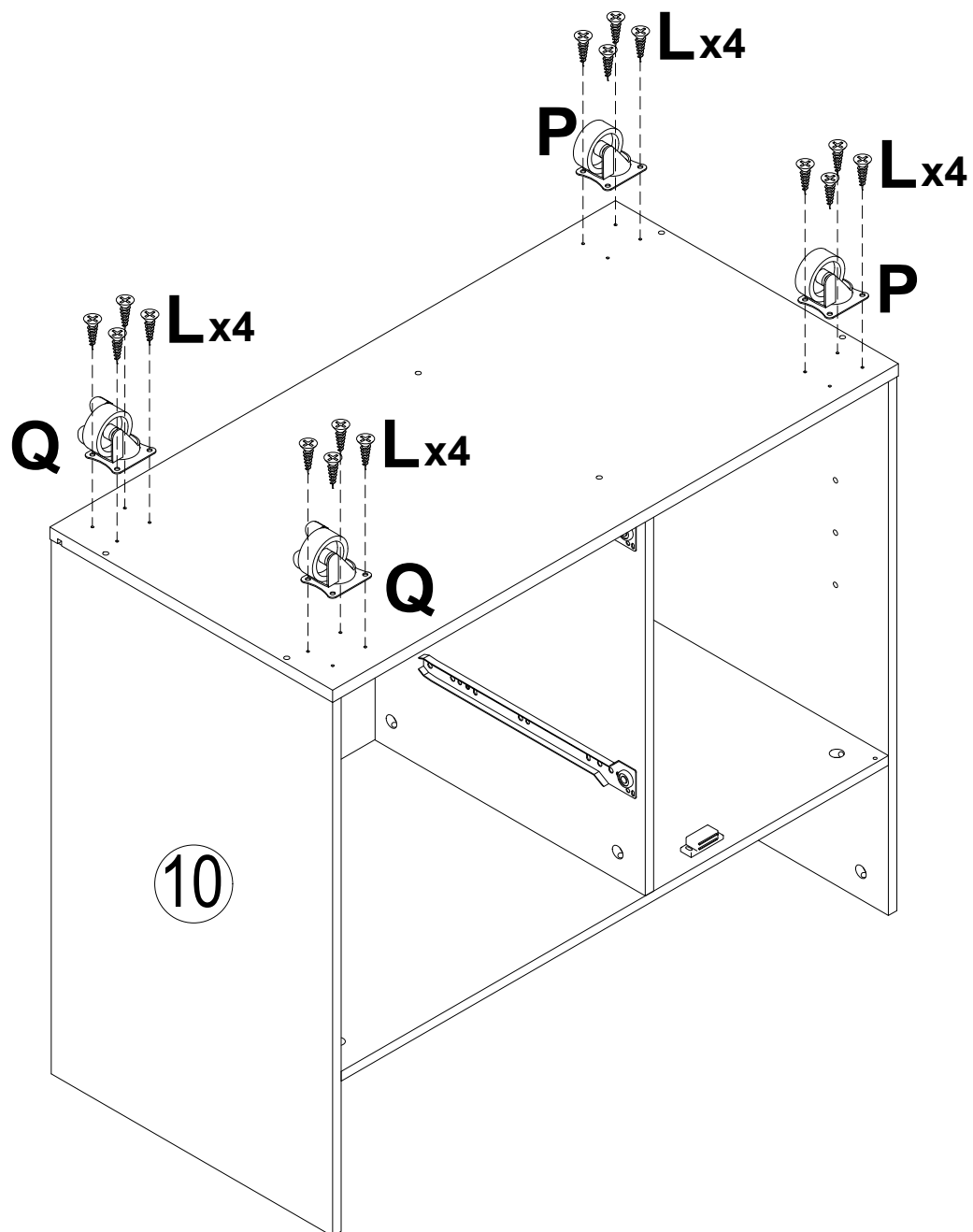

L M3.5X14



16 PCS

P

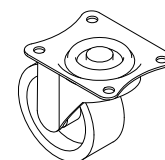

2 PCS

Q

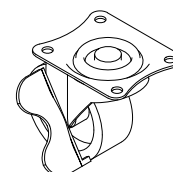

2 PCS

9

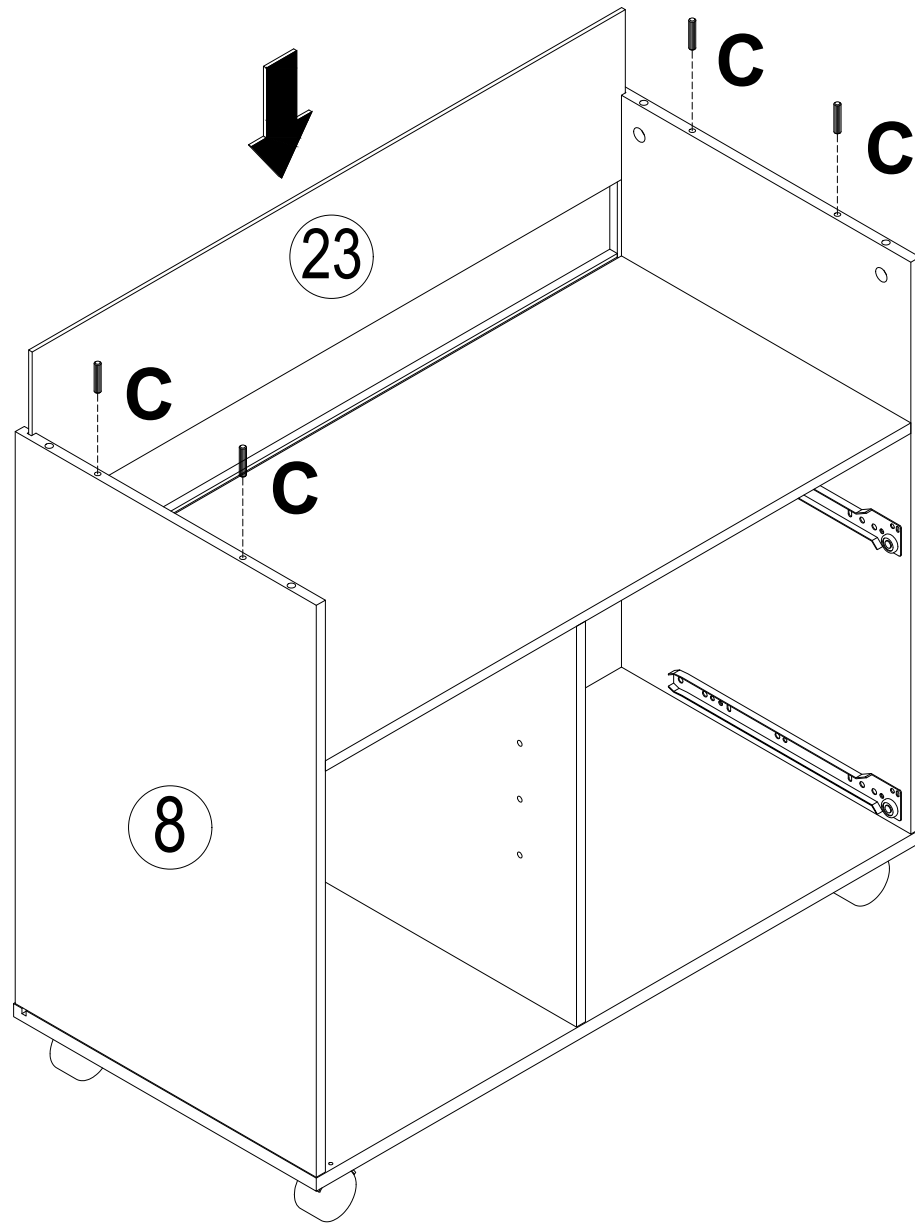

C Ø6x40



4 PCS

10

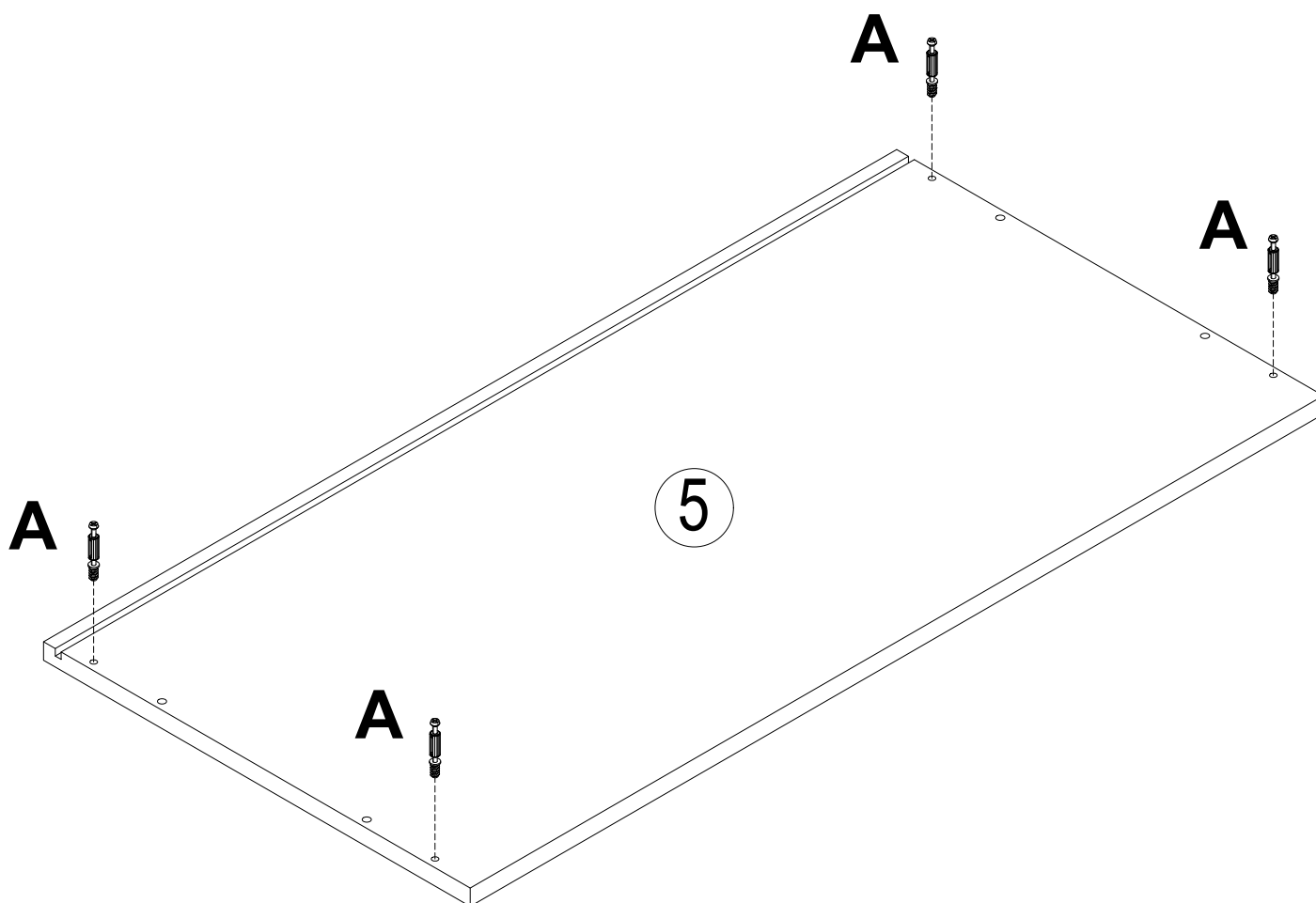
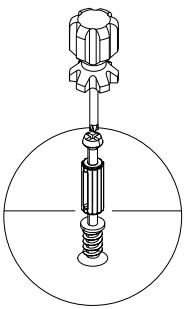

A M5X42



4 PCS

11

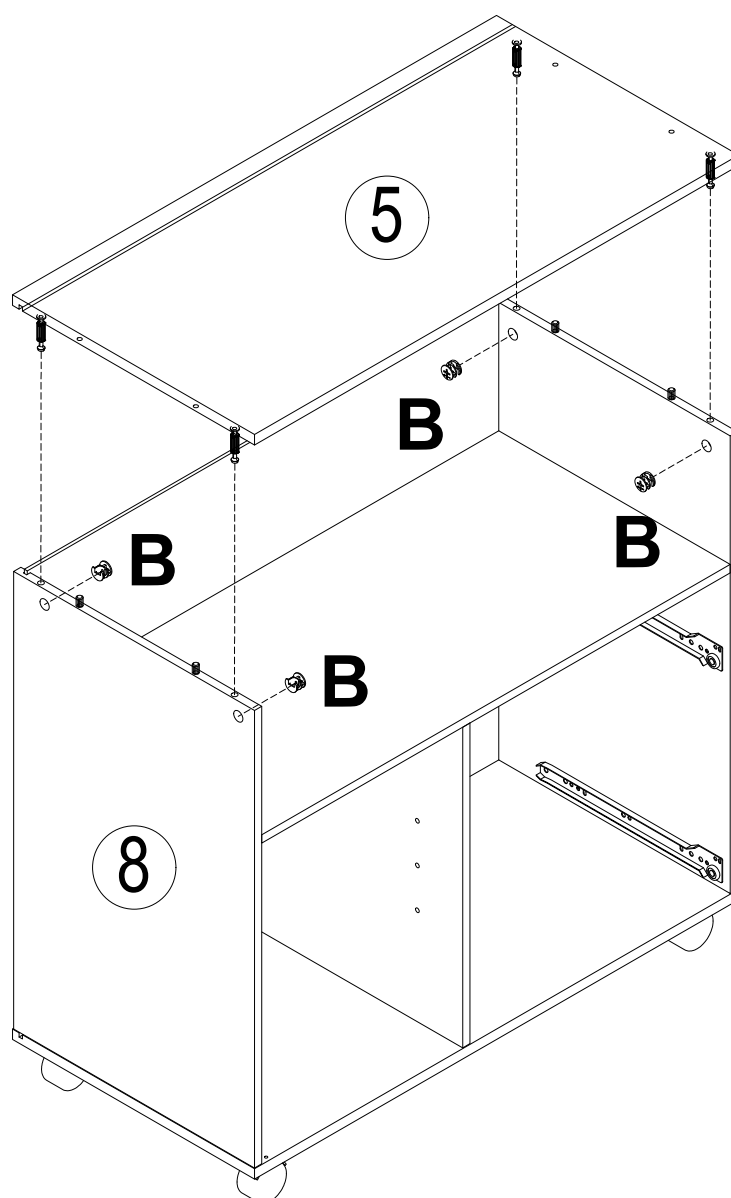
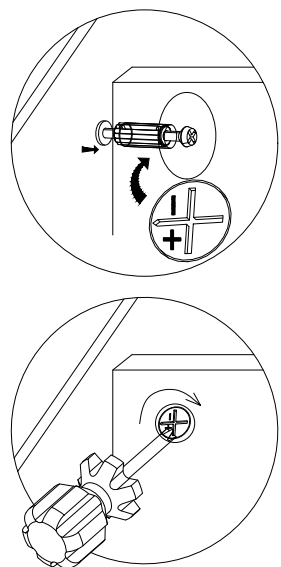

B Ø15x10

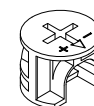

4 PCS

12

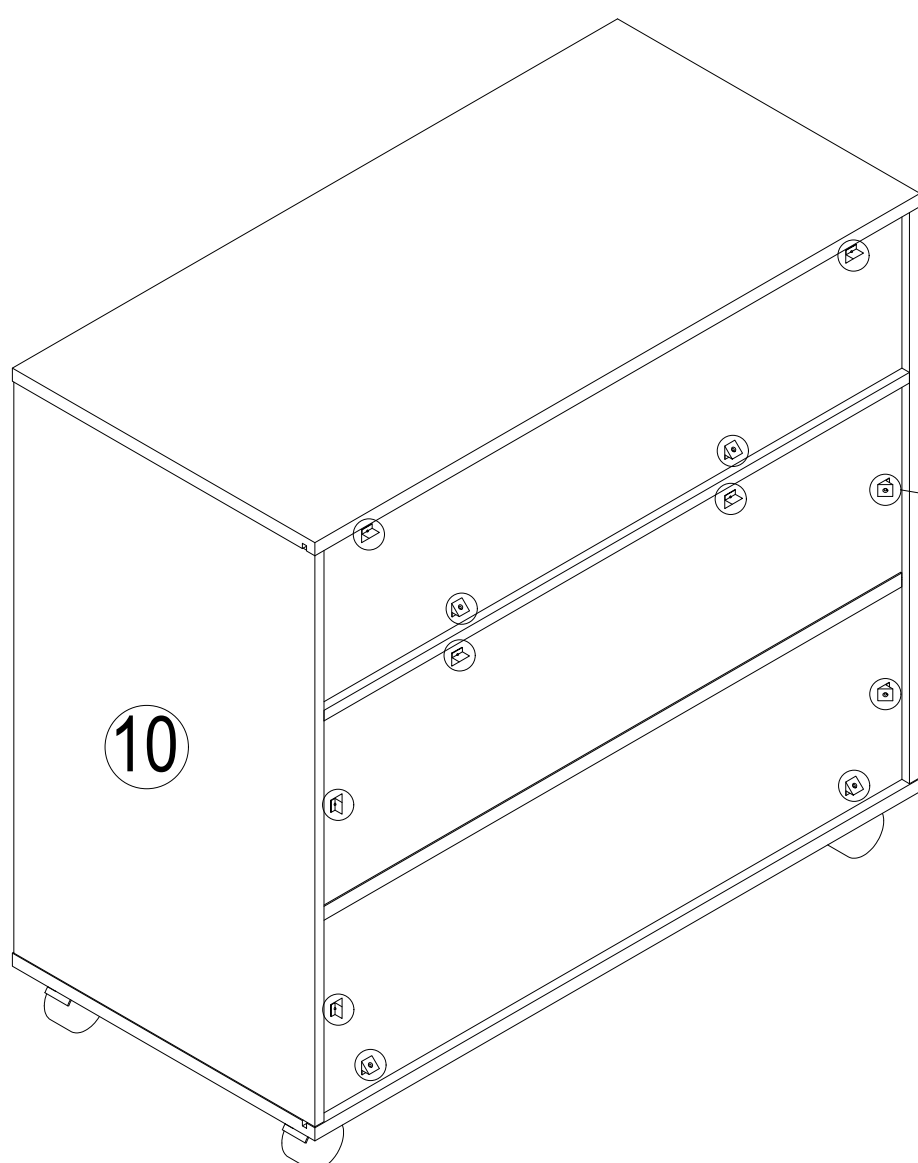

L M3.5X14



12 PCS

R

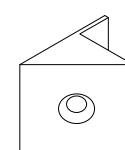

12 PCS

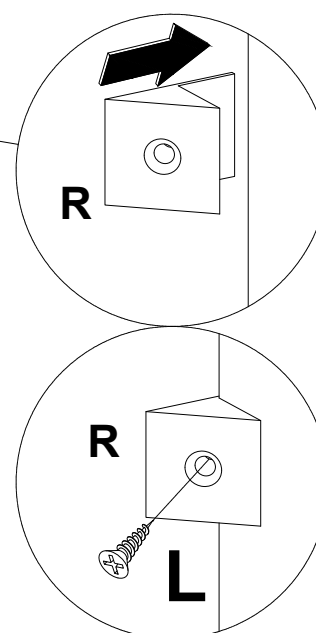

13

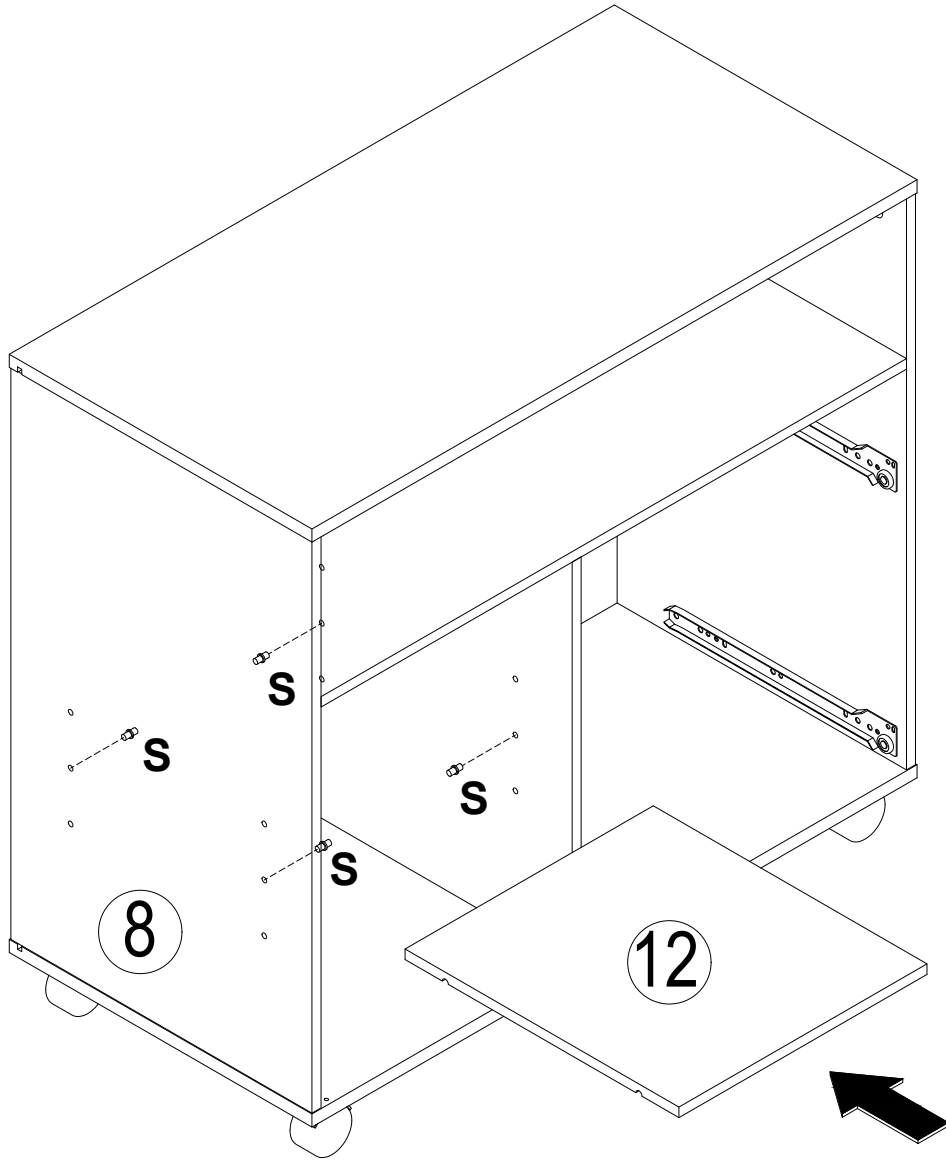
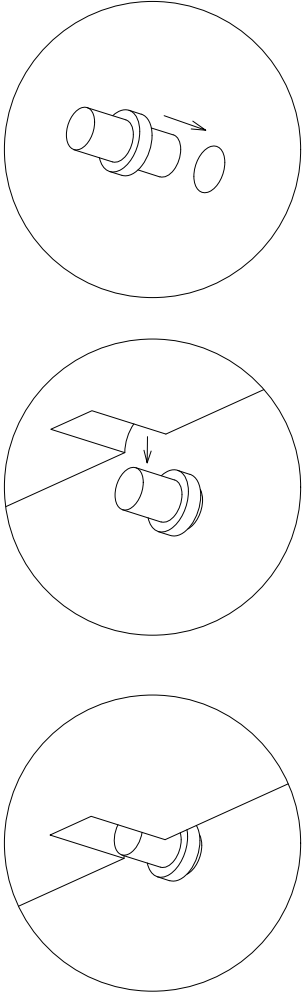

S

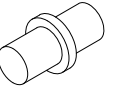

4 PCS

14

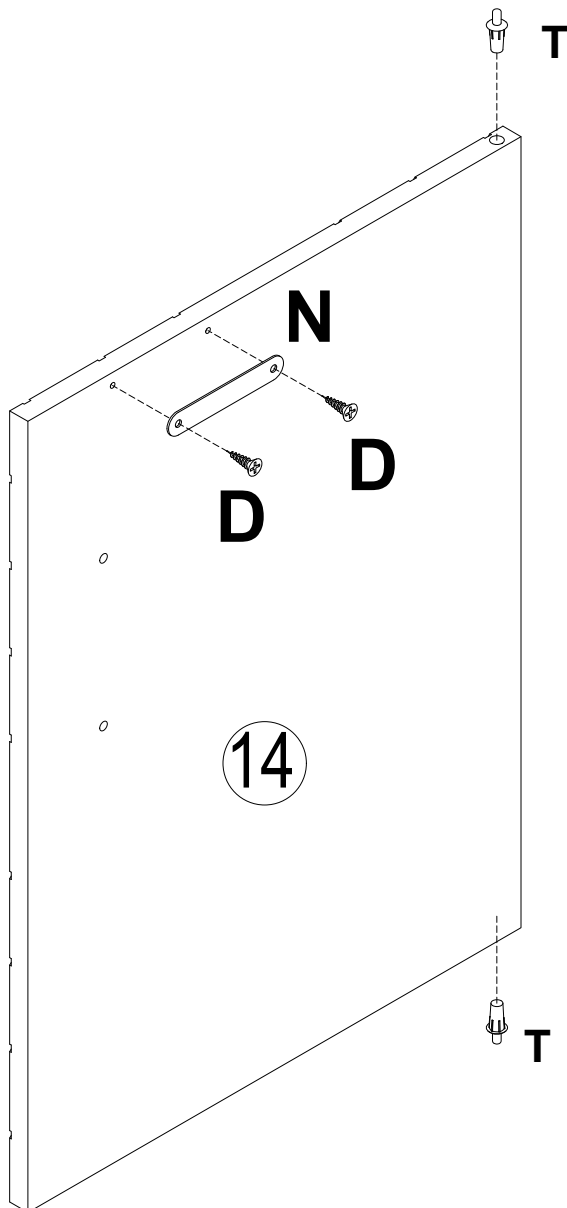

D M3.5X12



2 PCS

N

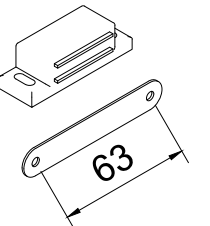

1 PCS

T

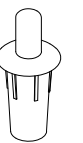

2 PCS

15

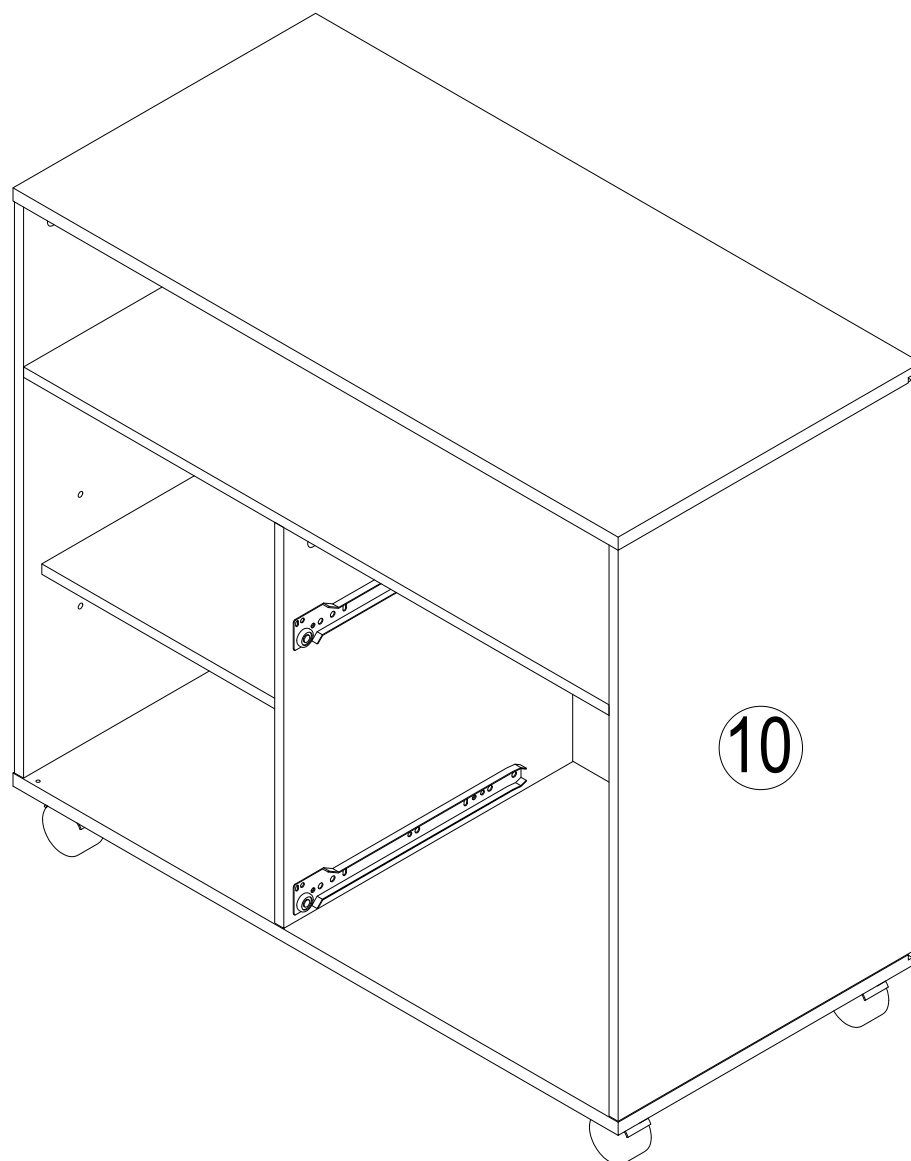
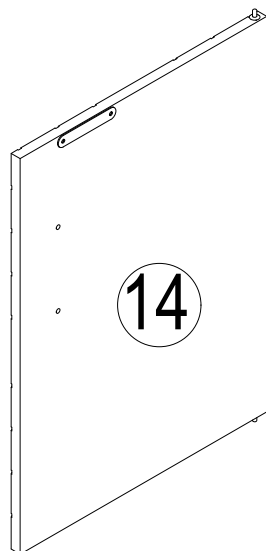
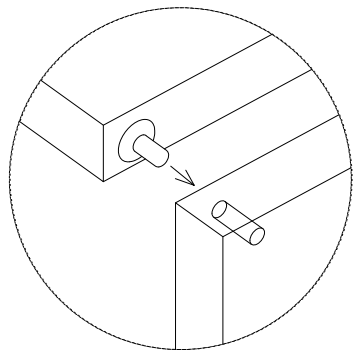
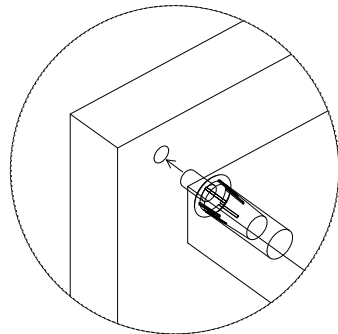

16

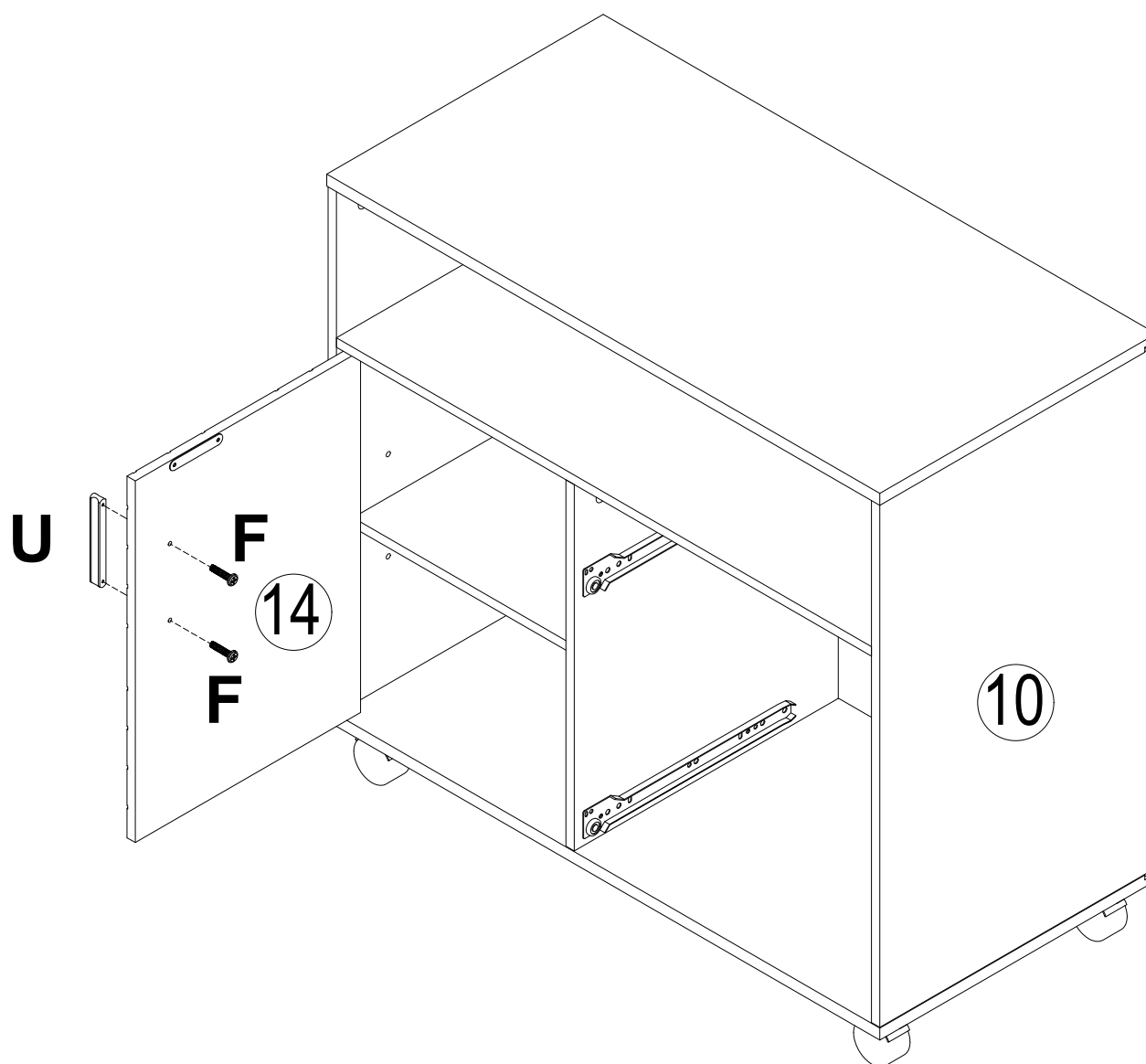

F M4X16



2 PCS

U 063-96



1 PCS

17

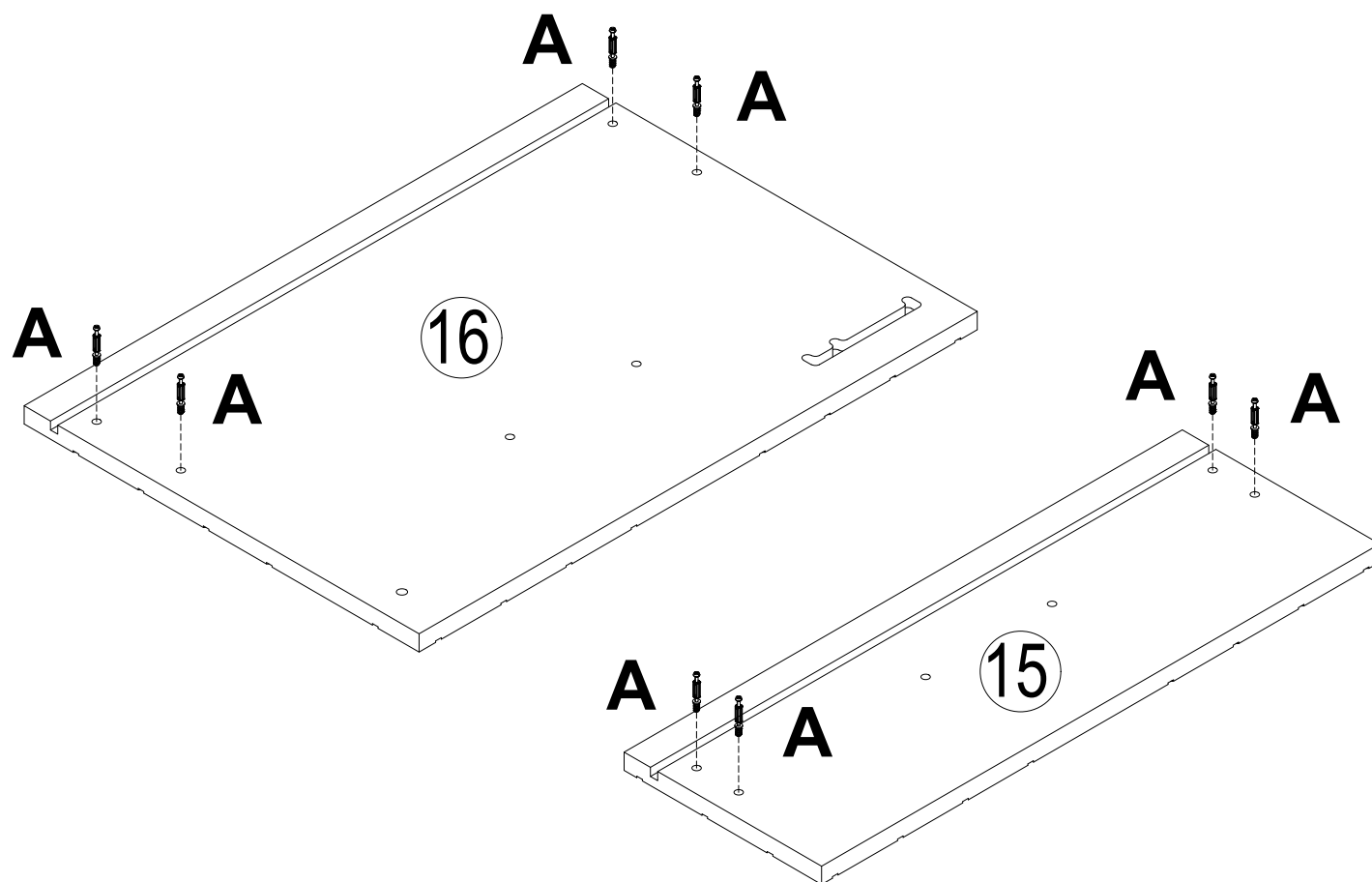
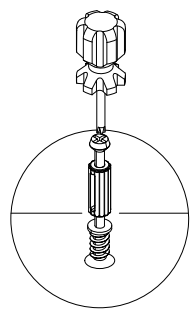

A M5X42



8 PCS

18

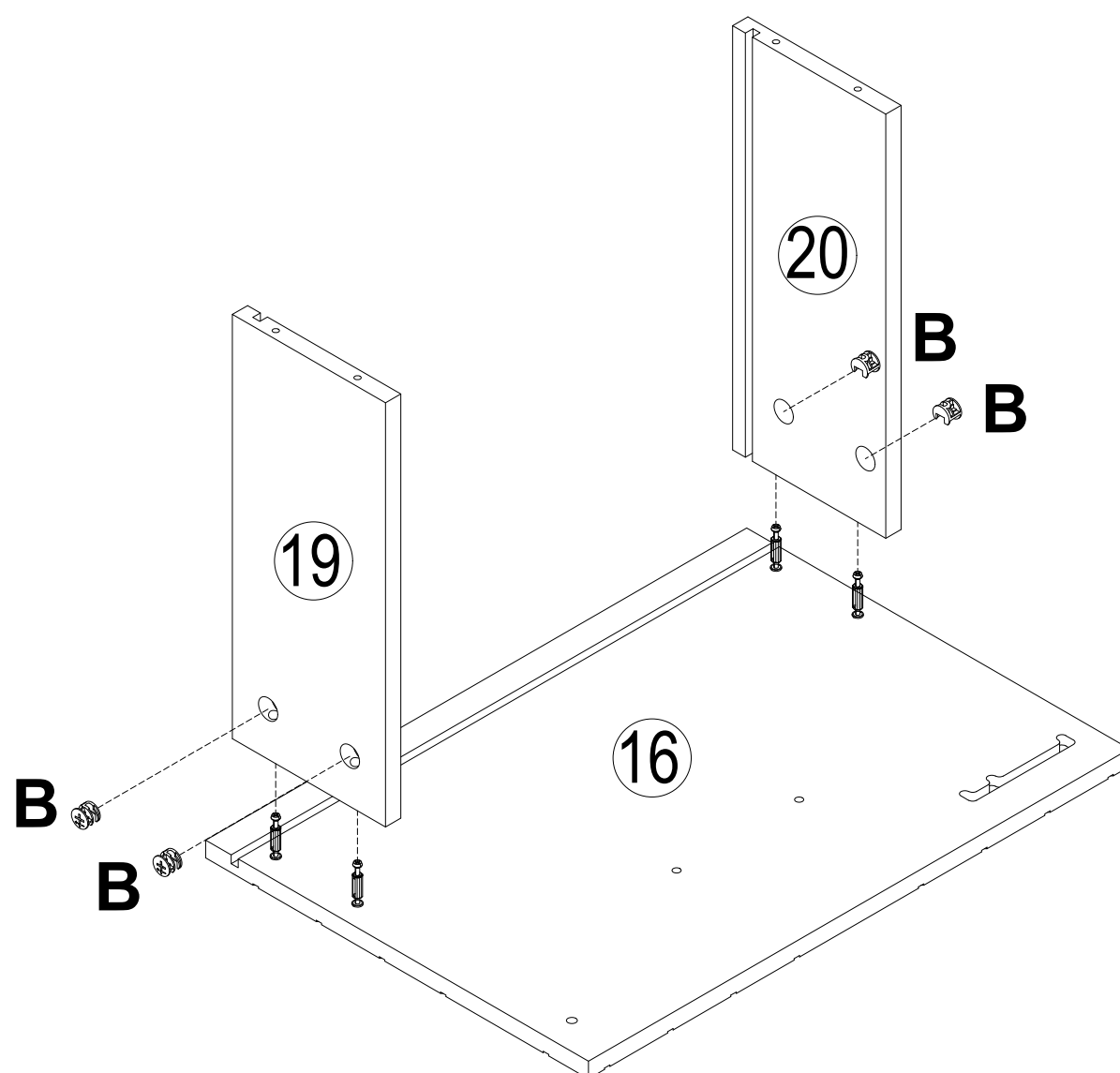
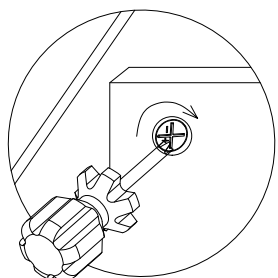
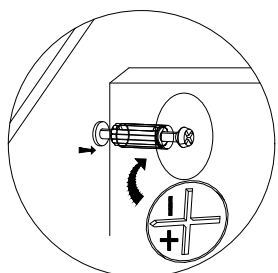

B Ø15x10

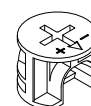

4 PCS

19

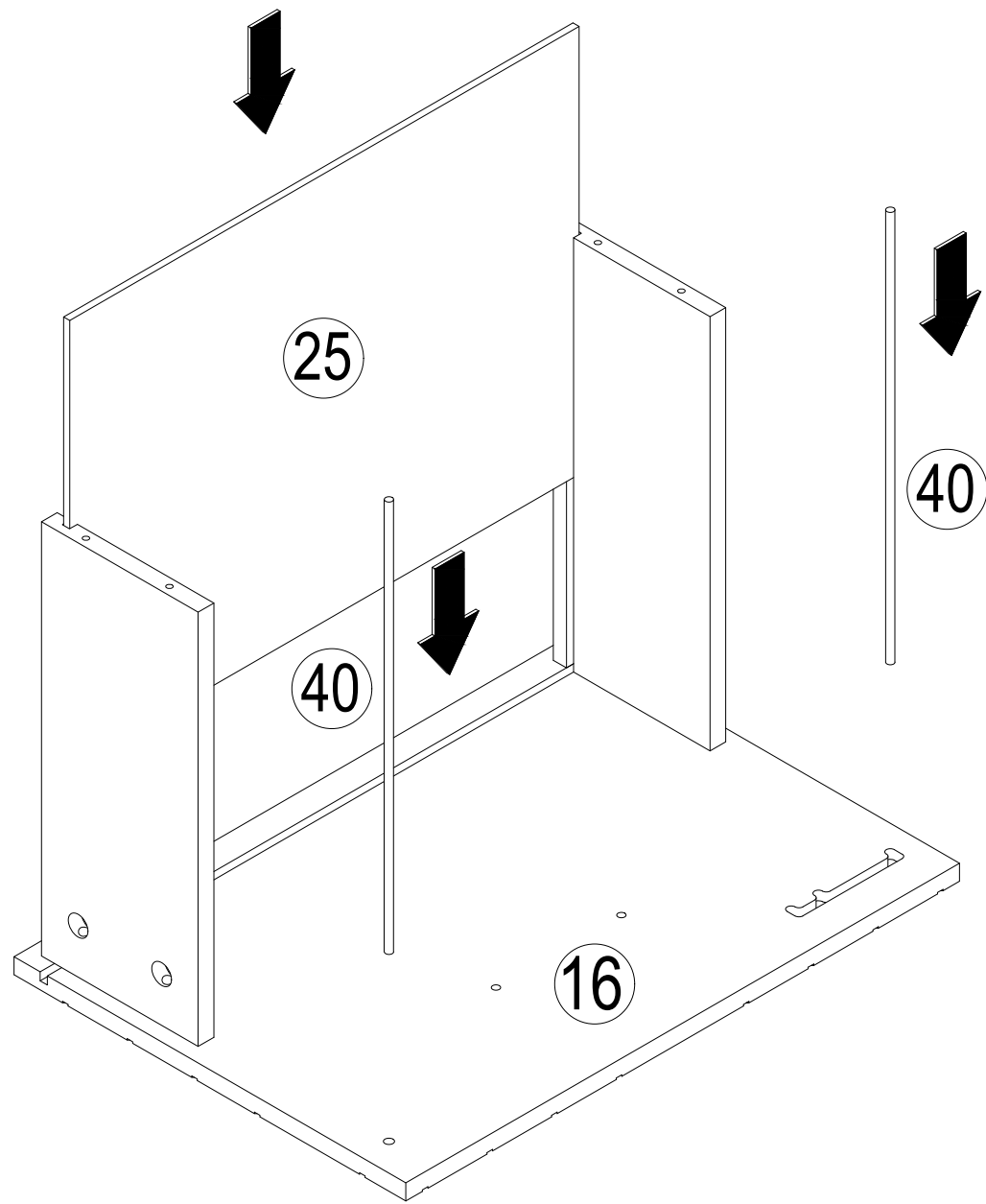

20

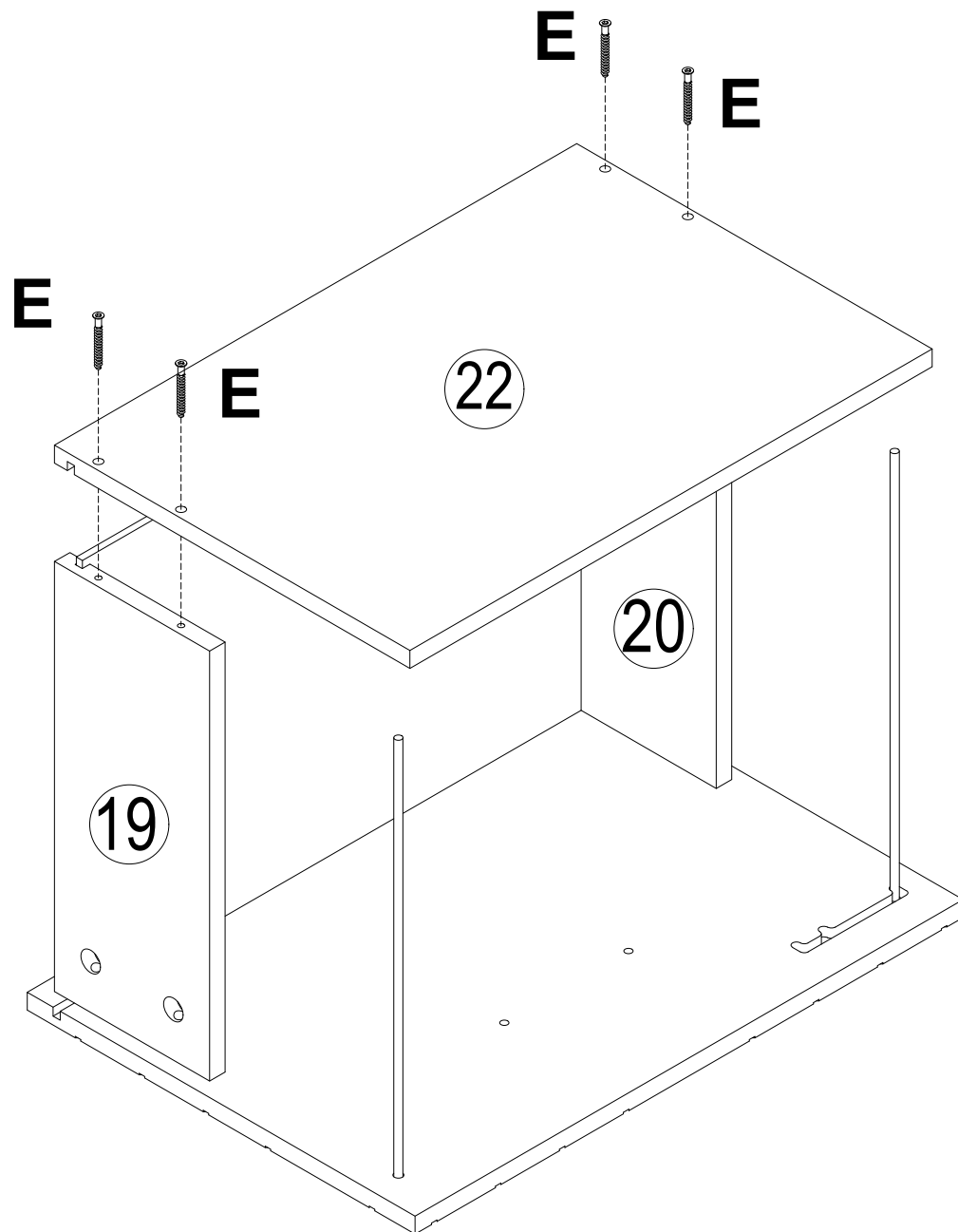

E M5X40



4 PCS

21

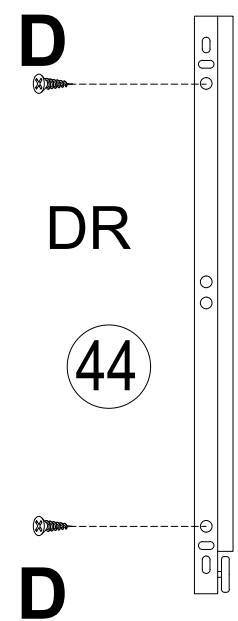
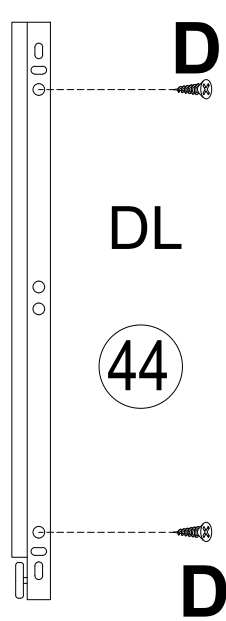
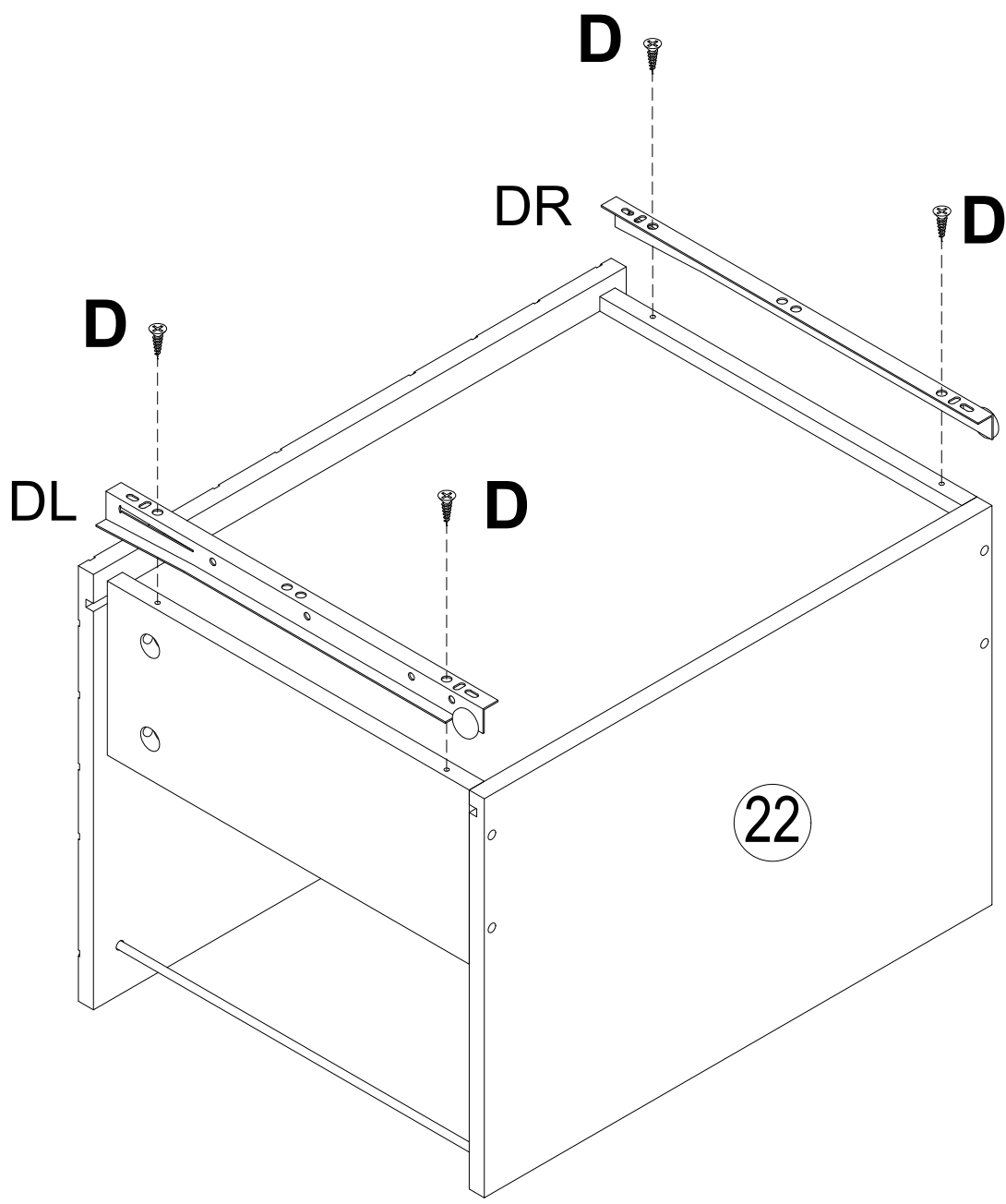

D M3.5X12



4 PCS

22

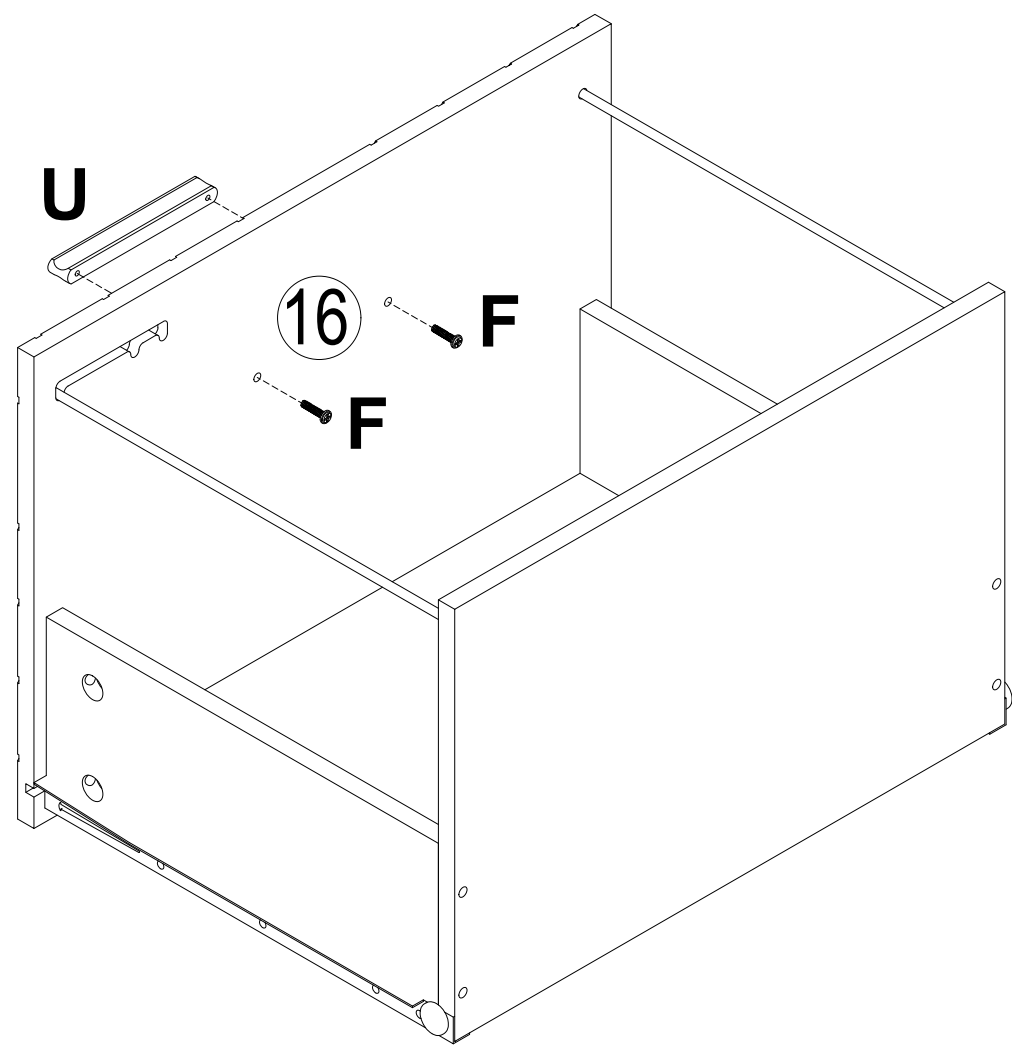

F M4X16

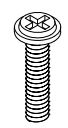

2 PCS

U 063-96

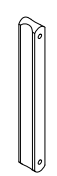

1 PCS

23

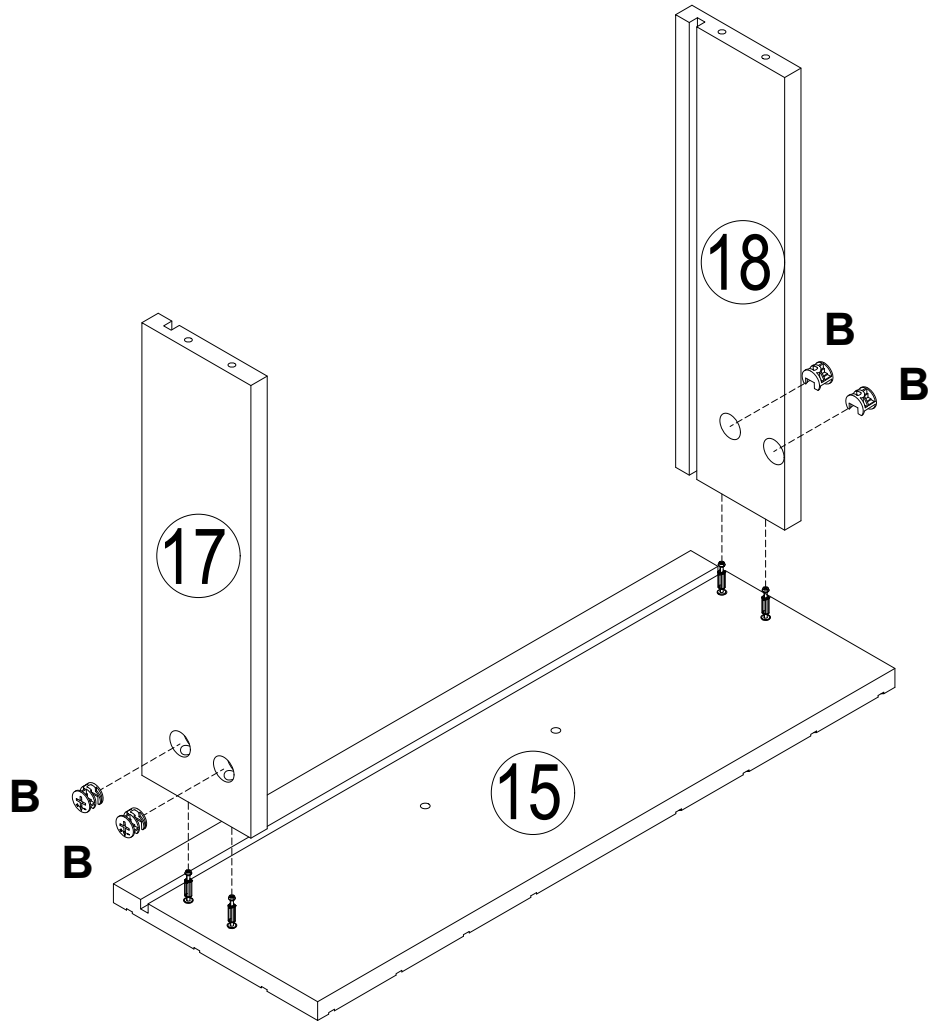
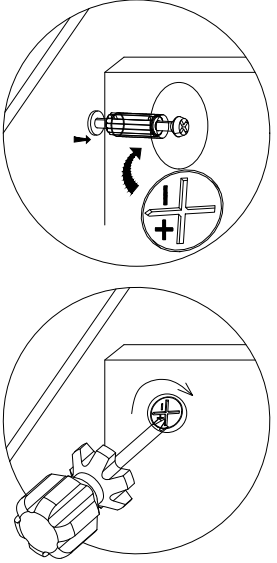

B Ø15x10

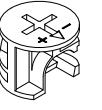

4 PCS

24

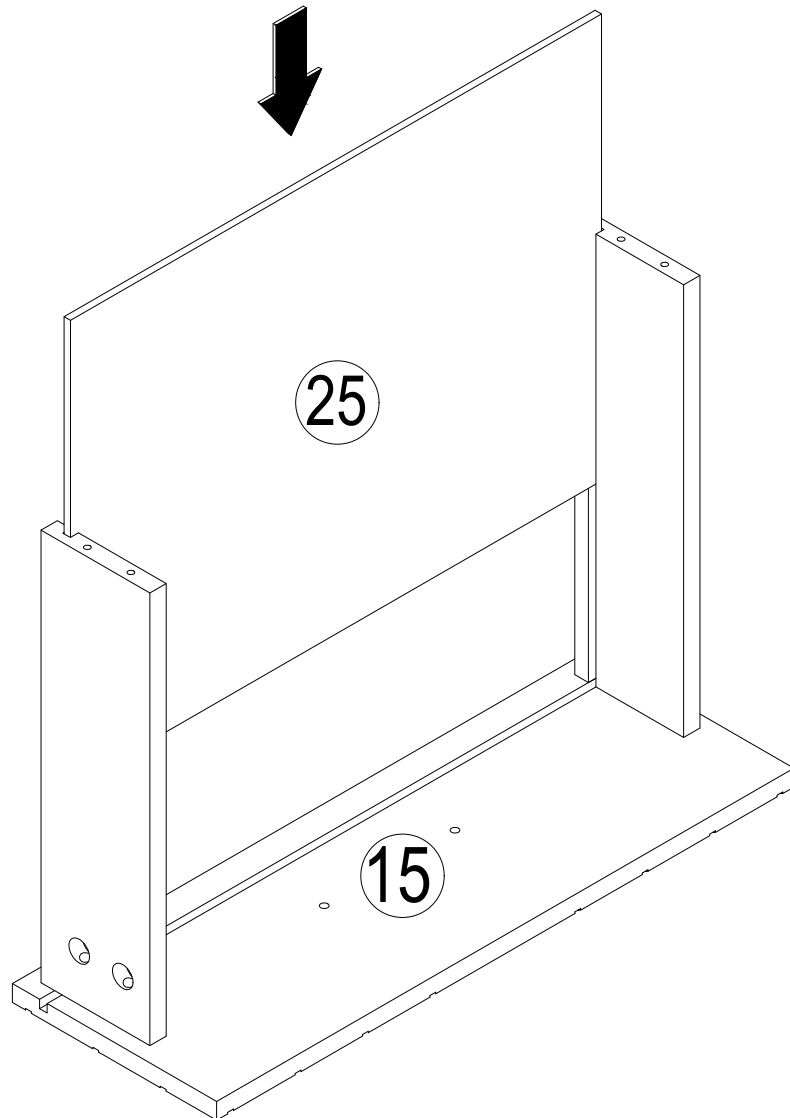

25

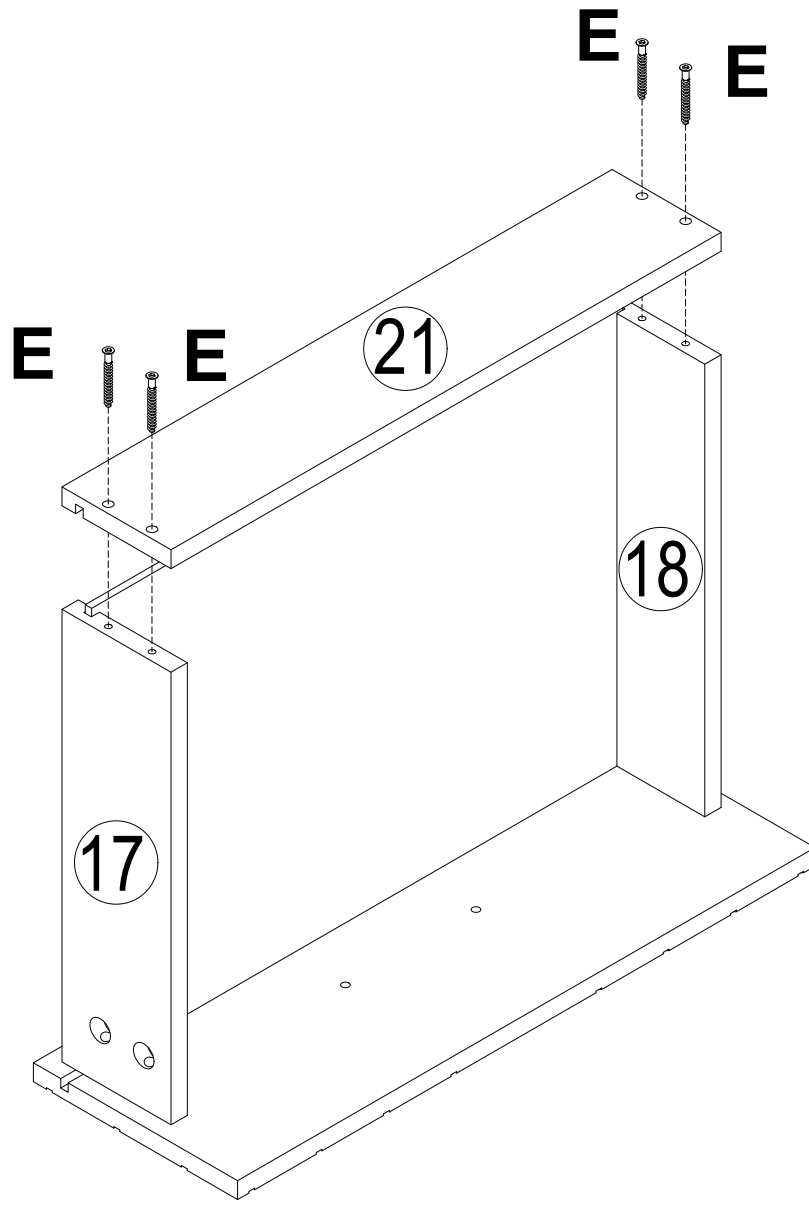

E M5X40



4 PCS

26

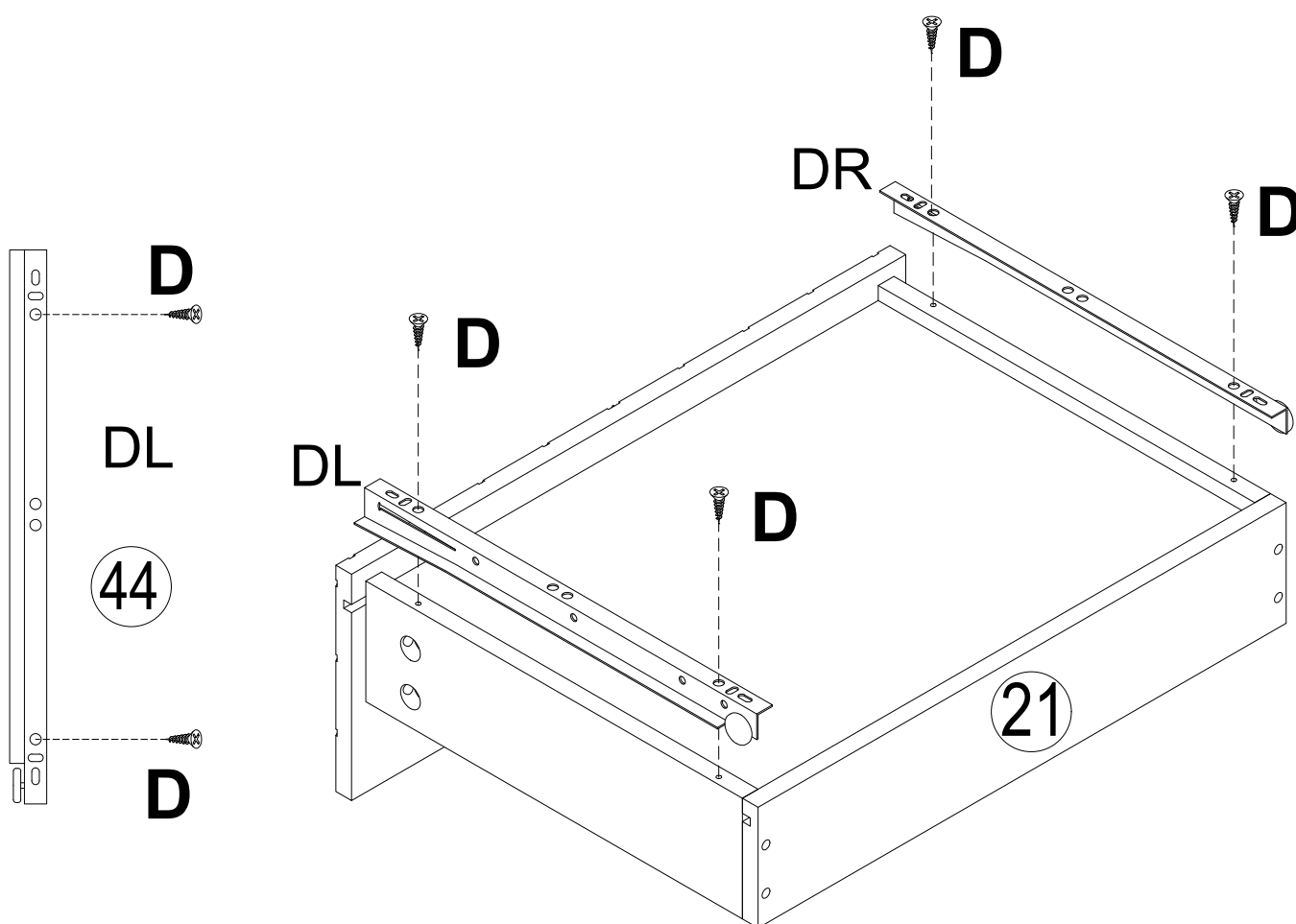

D M3.5X12



4 PCS

27

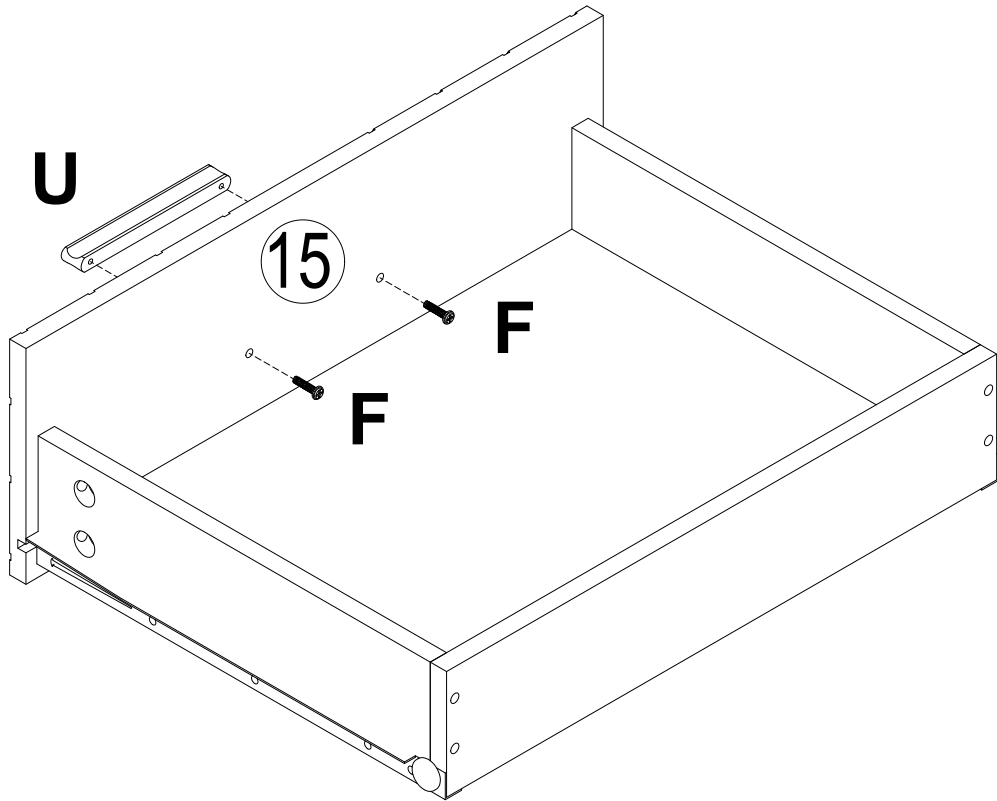

F M4X16

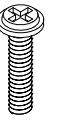

2 PCS

U 063-96



1 PCS

28

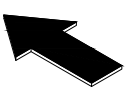
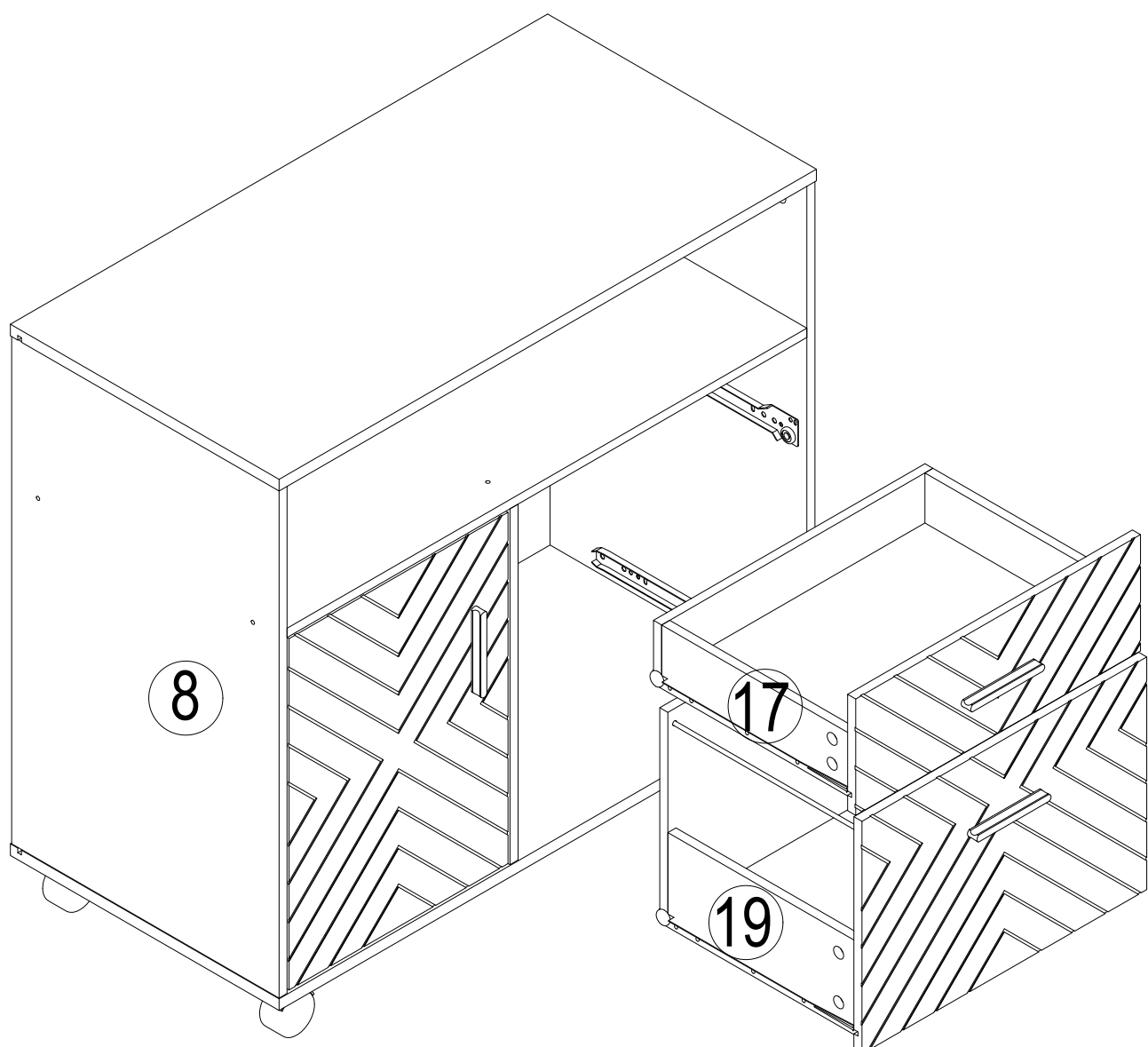
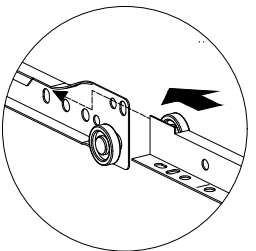
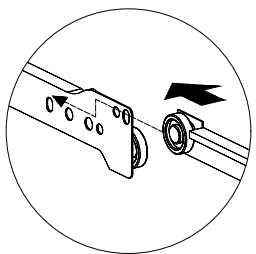

29

V A200
M8

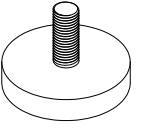

4 PCS

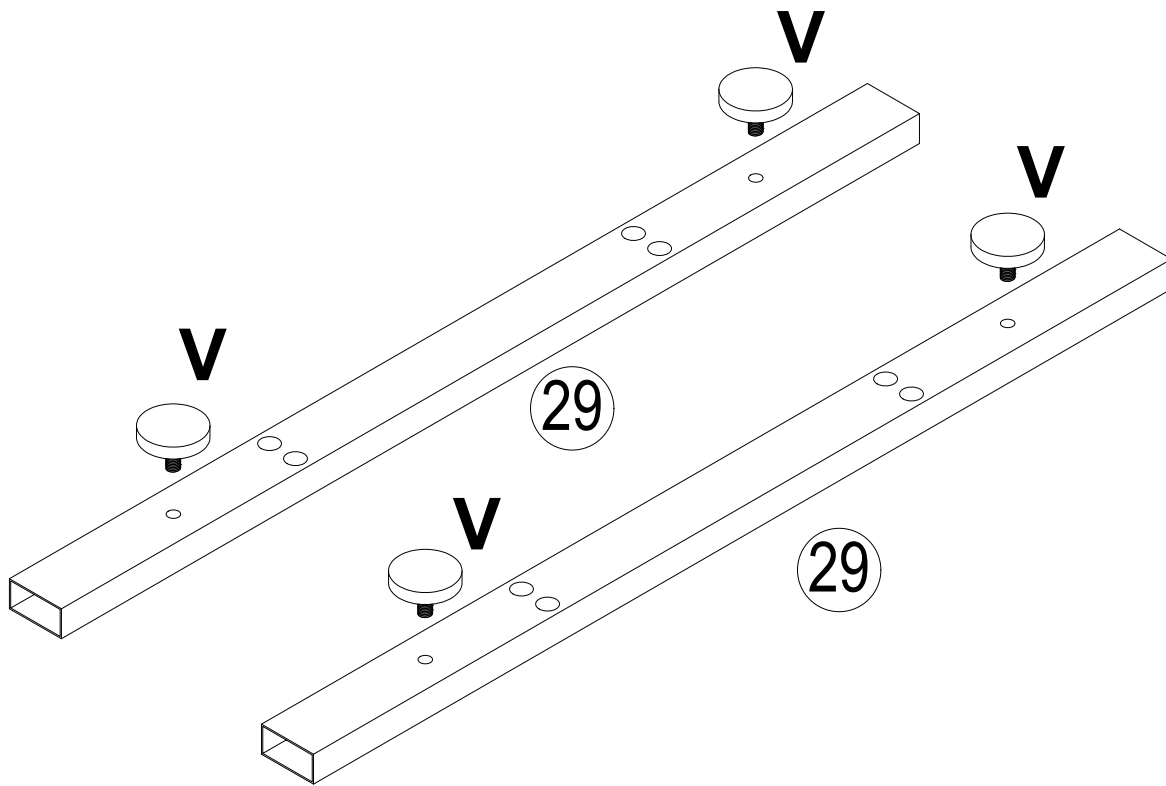

30

G M6X10

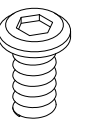

4 PCS

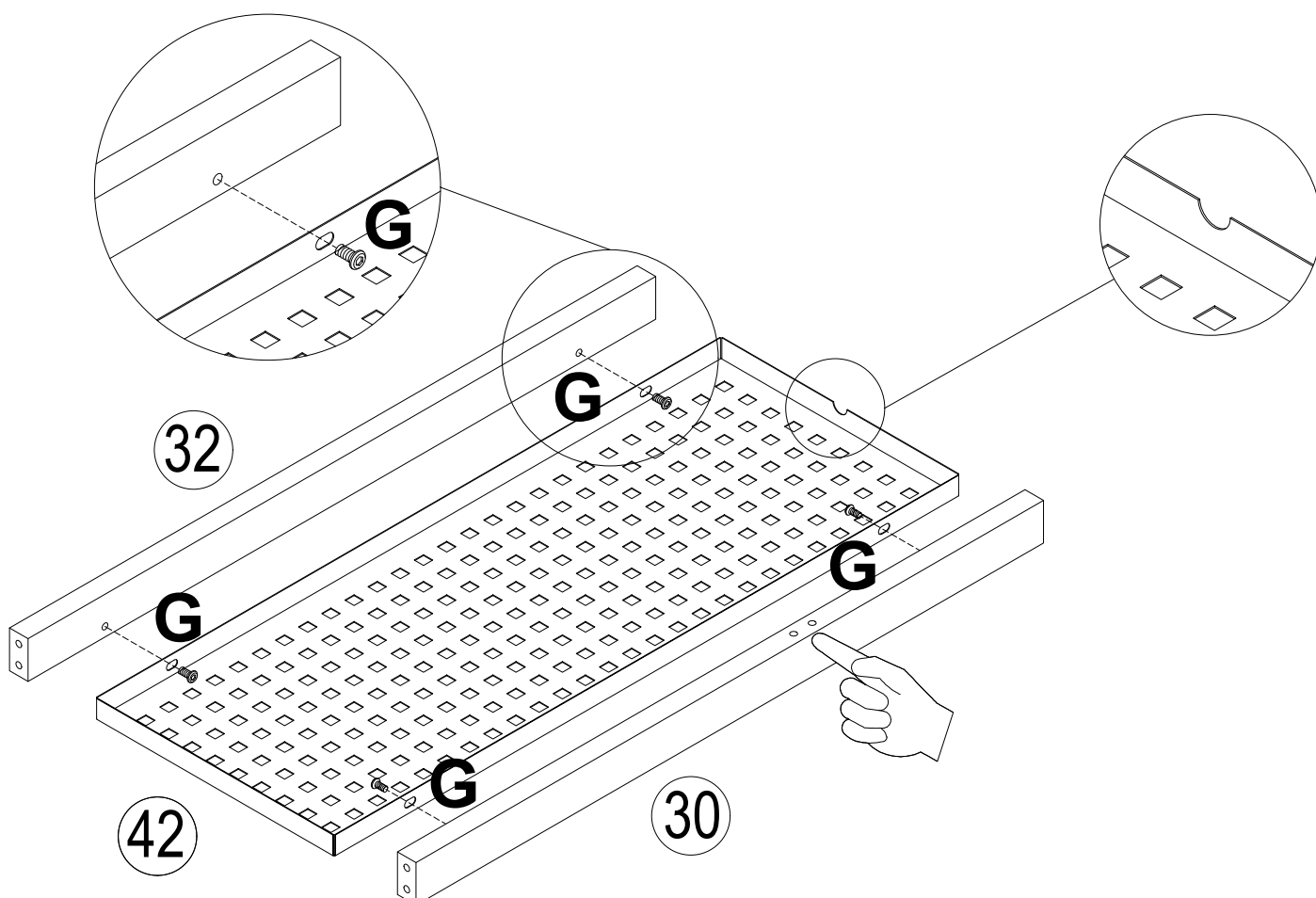

31

H M6X40



8 PCS

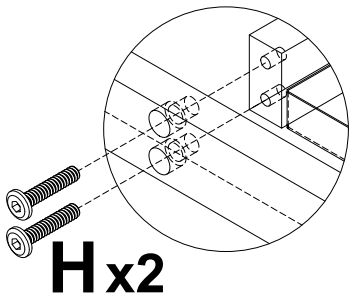

Hx2

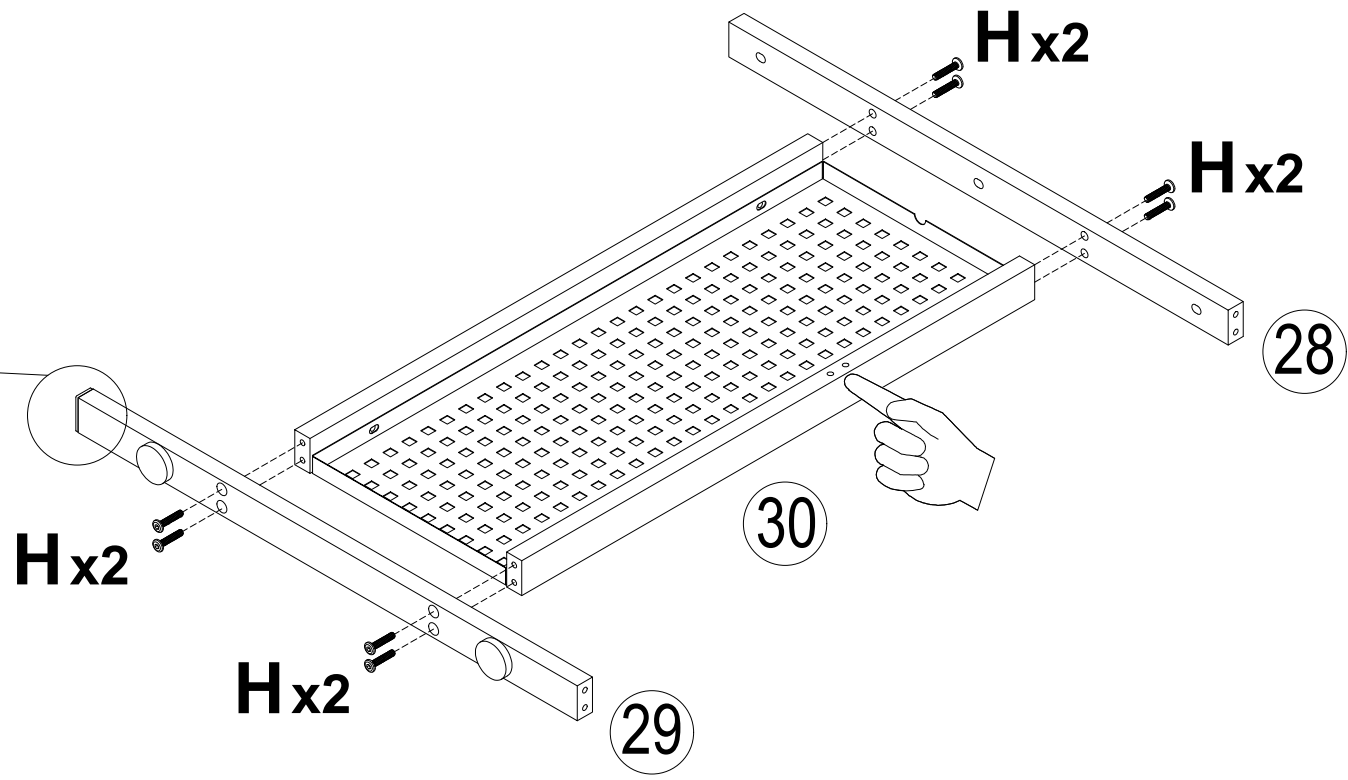
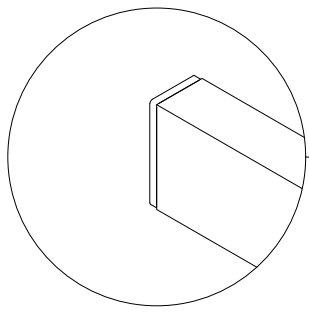

32

H M6X40

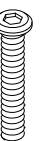

4 PCS

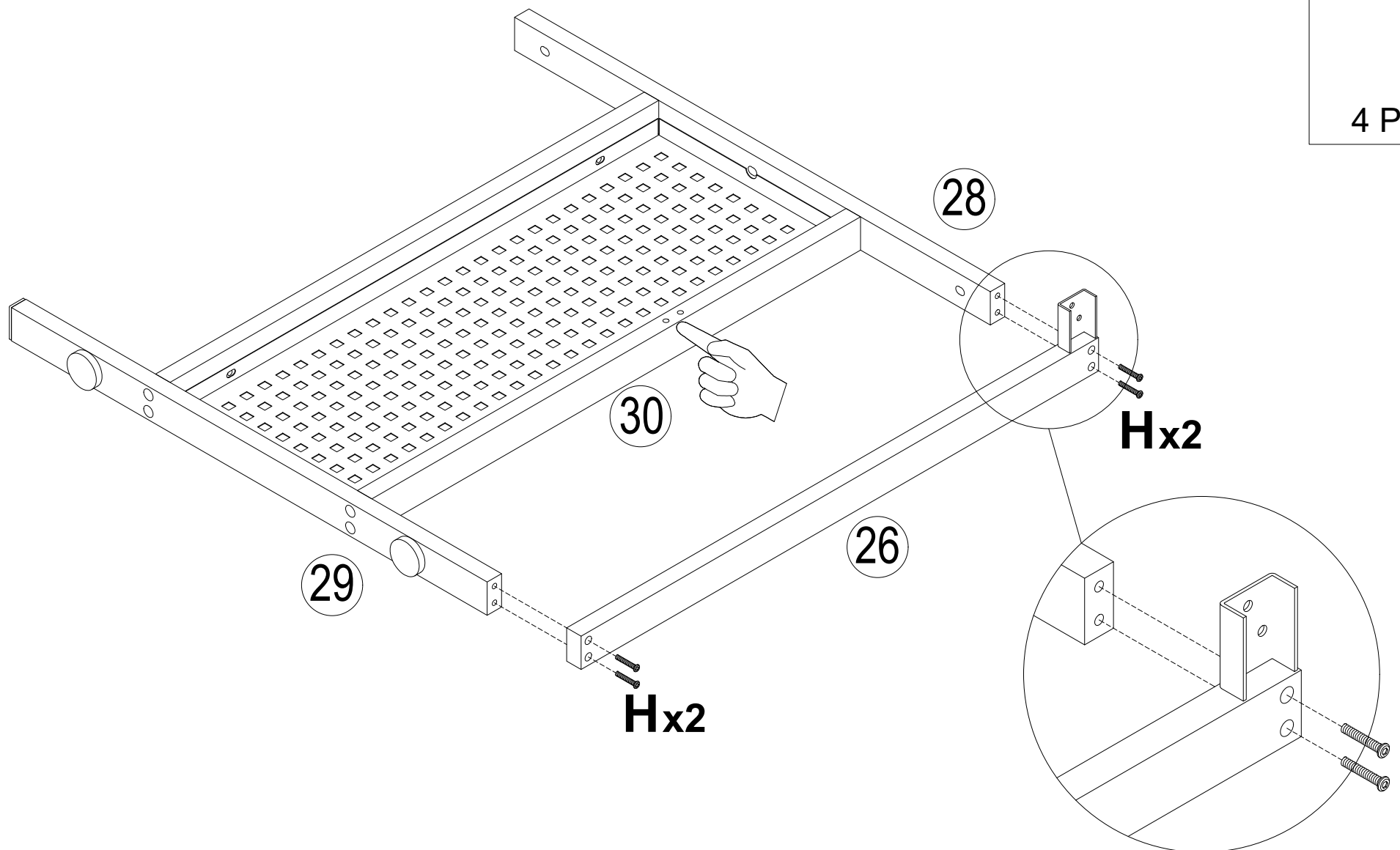

33

G M6X10

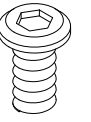

4 PCS

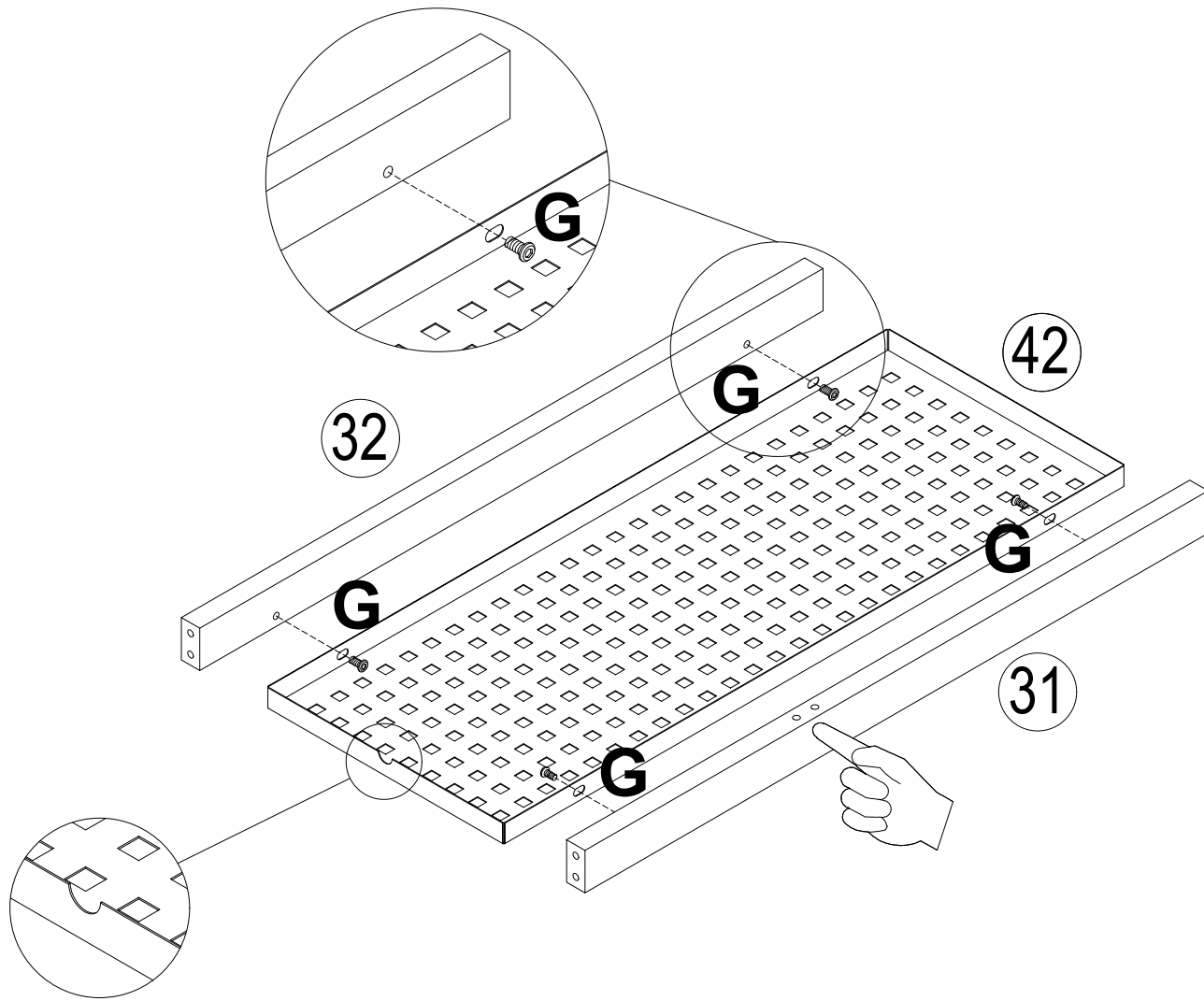

34

H M6X40



8 PCS

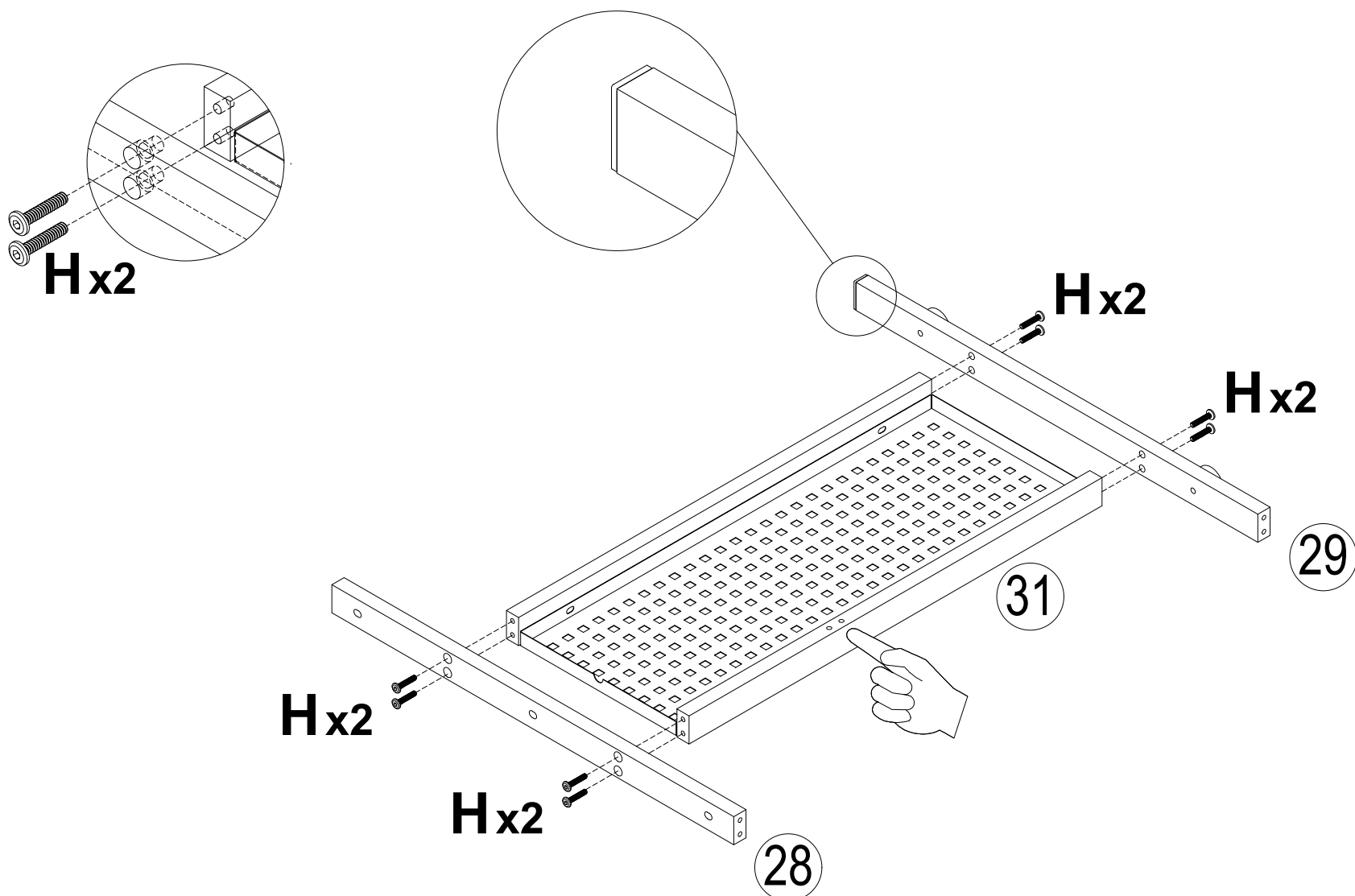

35

H M6X40

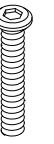

4 PCS

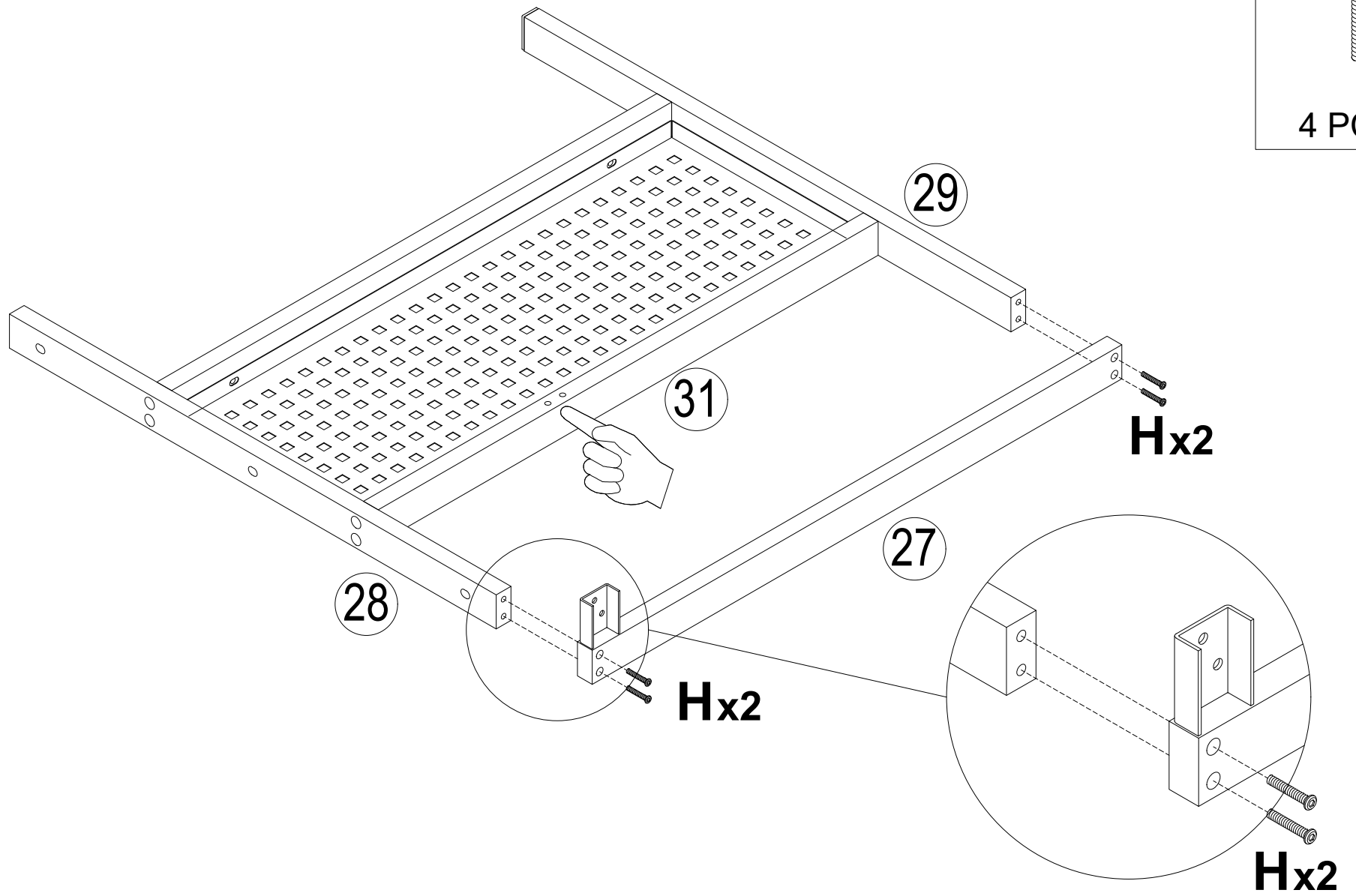

36

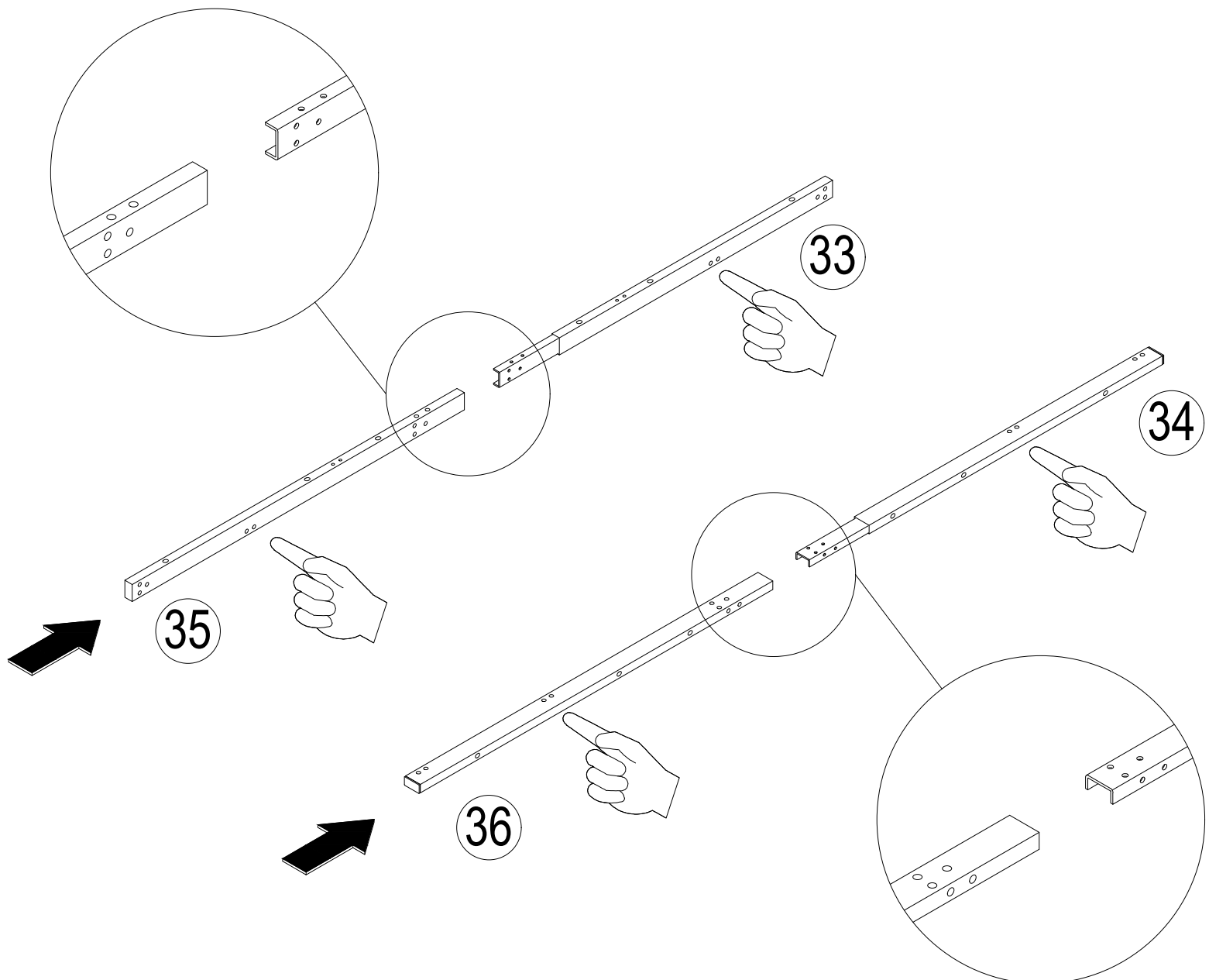

37

G M6X10

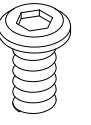

10 PCS

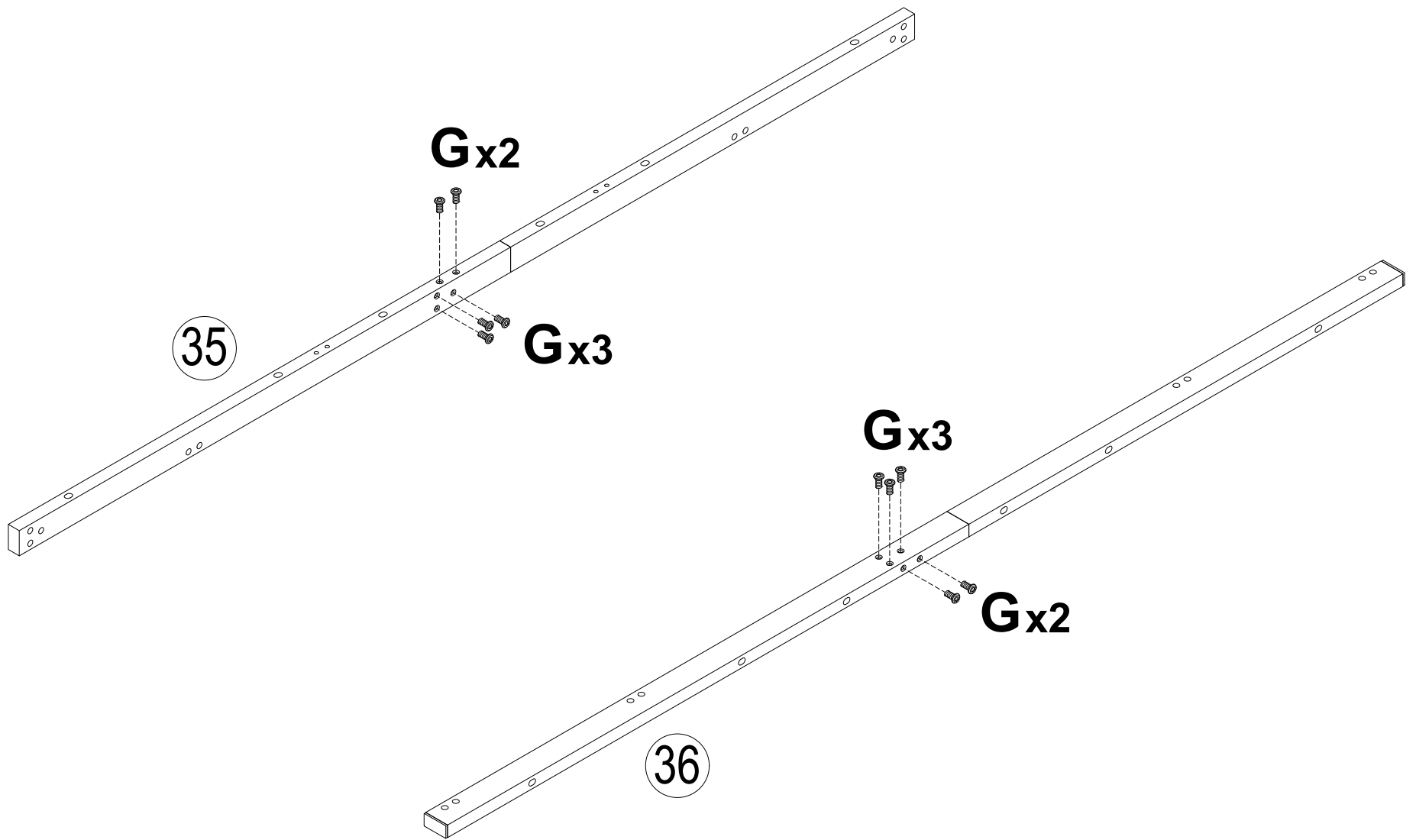

38

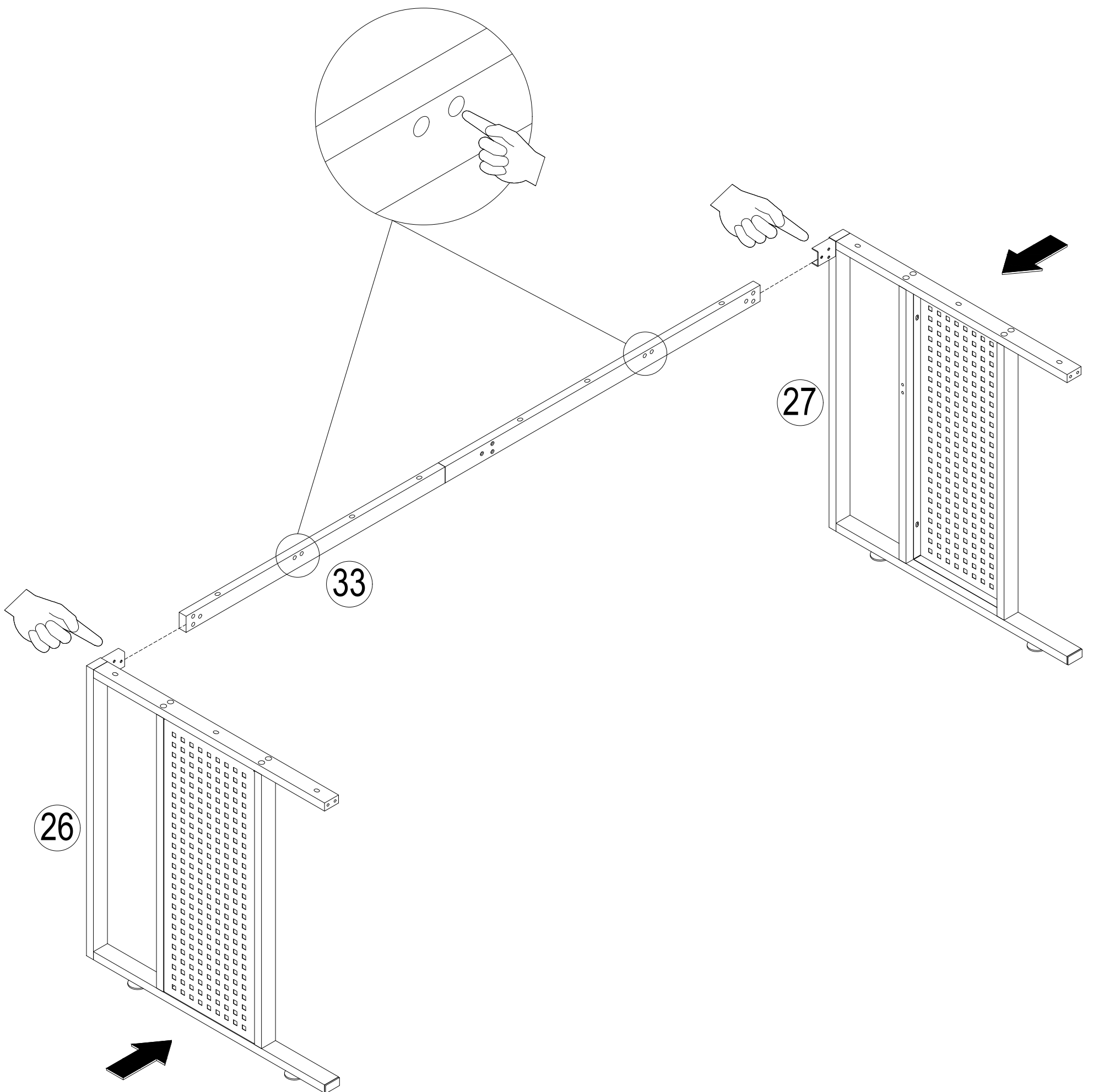

39

Pre-tighten screws to 70%,
then finally tighten all screws
simultaneously to 99%.

G M6X10



6 PCS

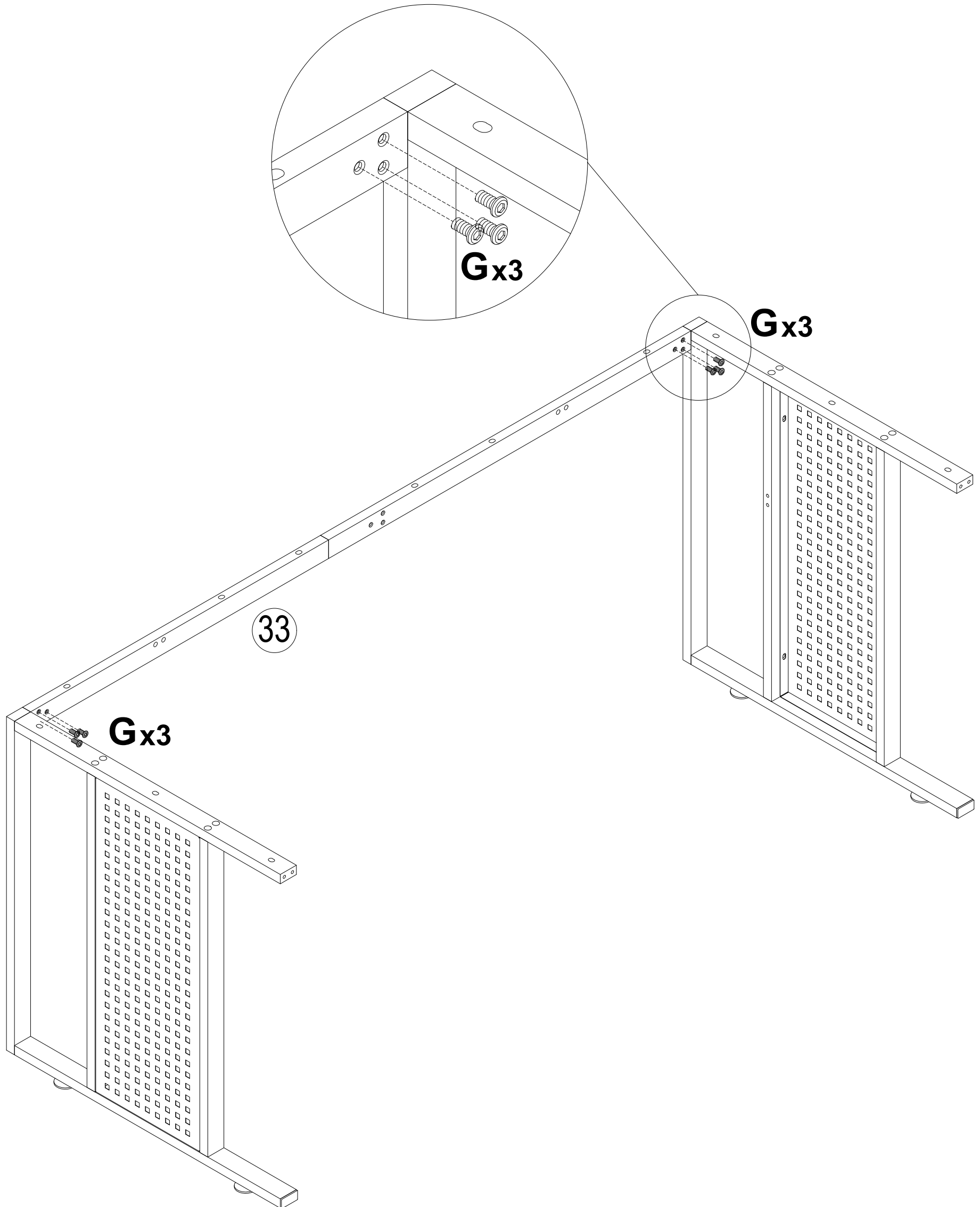

40

Pre-tighten screws to 70%,
then finally tighten all screws
simultaneously to 99%.

H M6X40

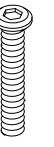

4 PCS

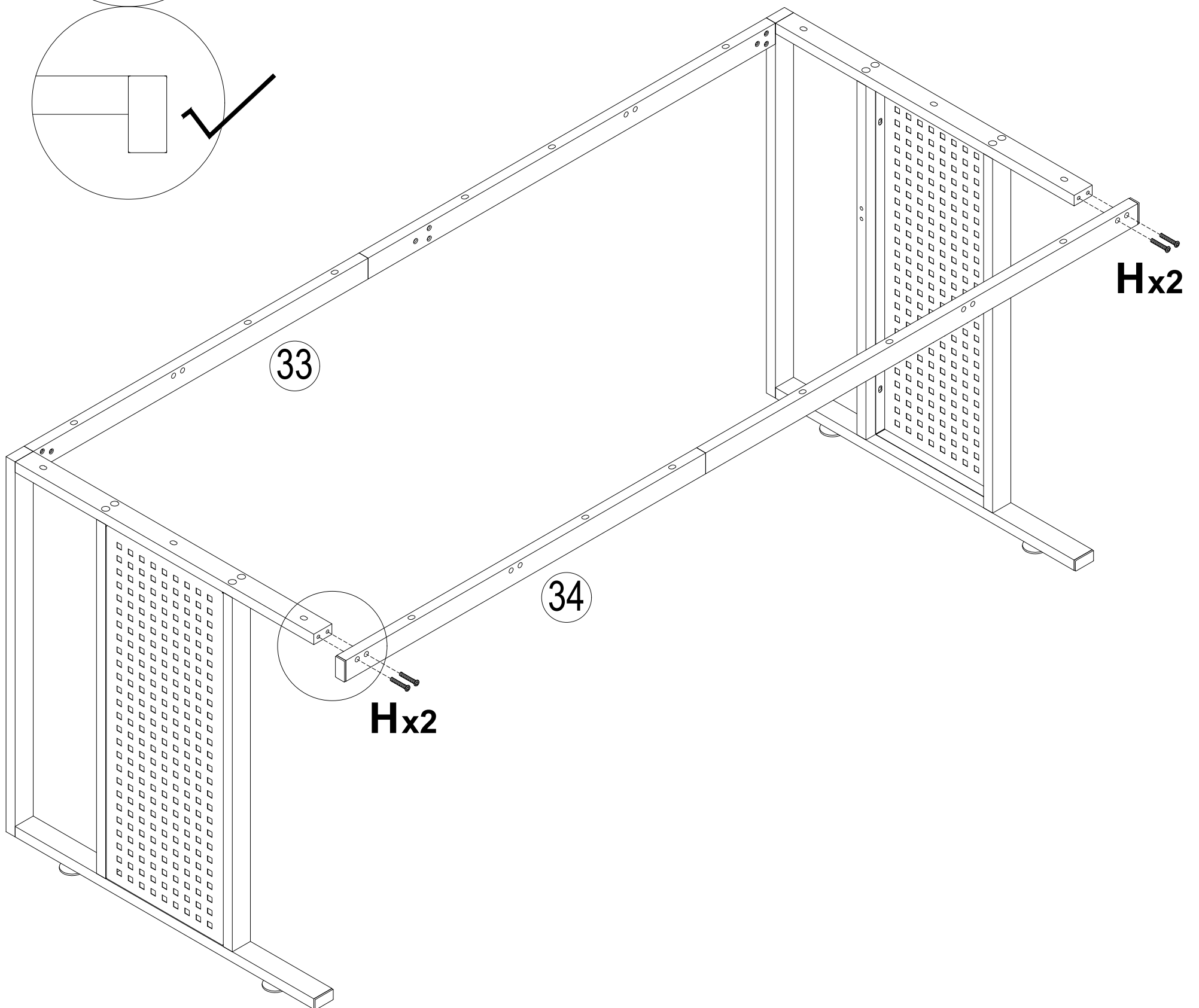
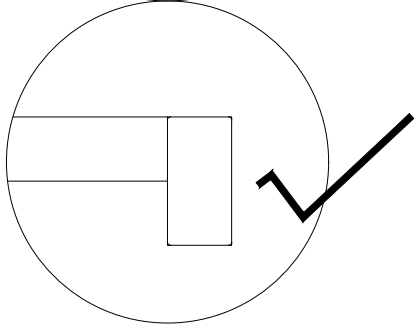
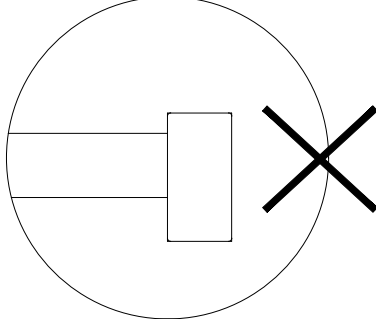
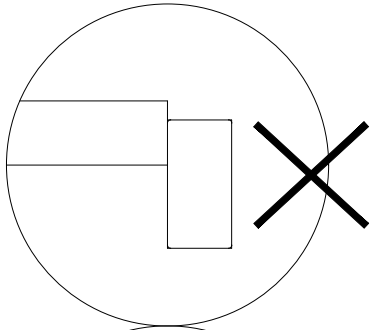

41

Pre-tighten screws to 70%,
then finally tighten all screws
simultaneously to 99%.

H M6X40

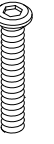

8 PCS

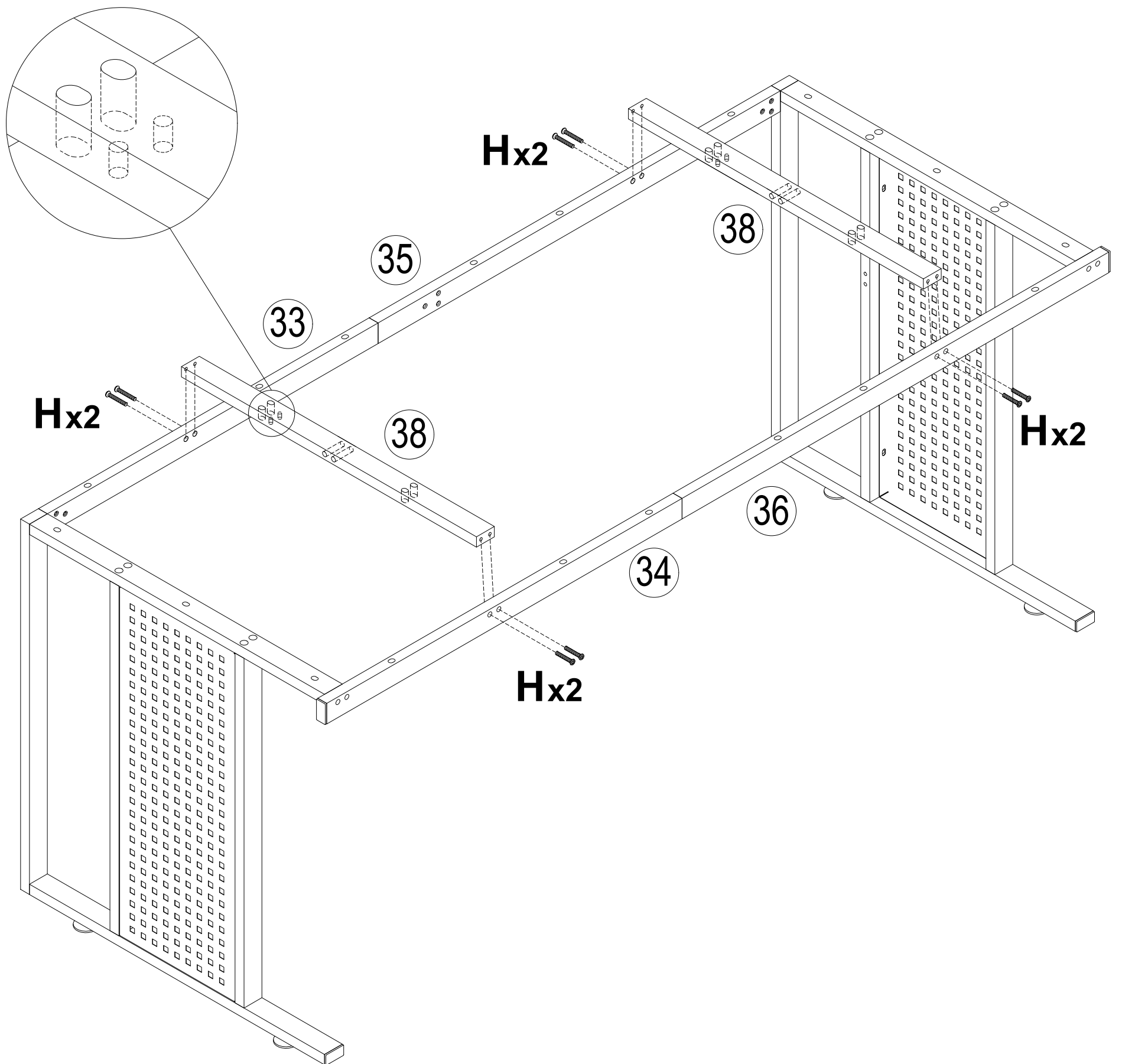

42

Pre-tighten screws to 70%,
then finally tighten all screws
simultaneously to 99%.

J M6X60

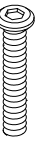

4 PCS

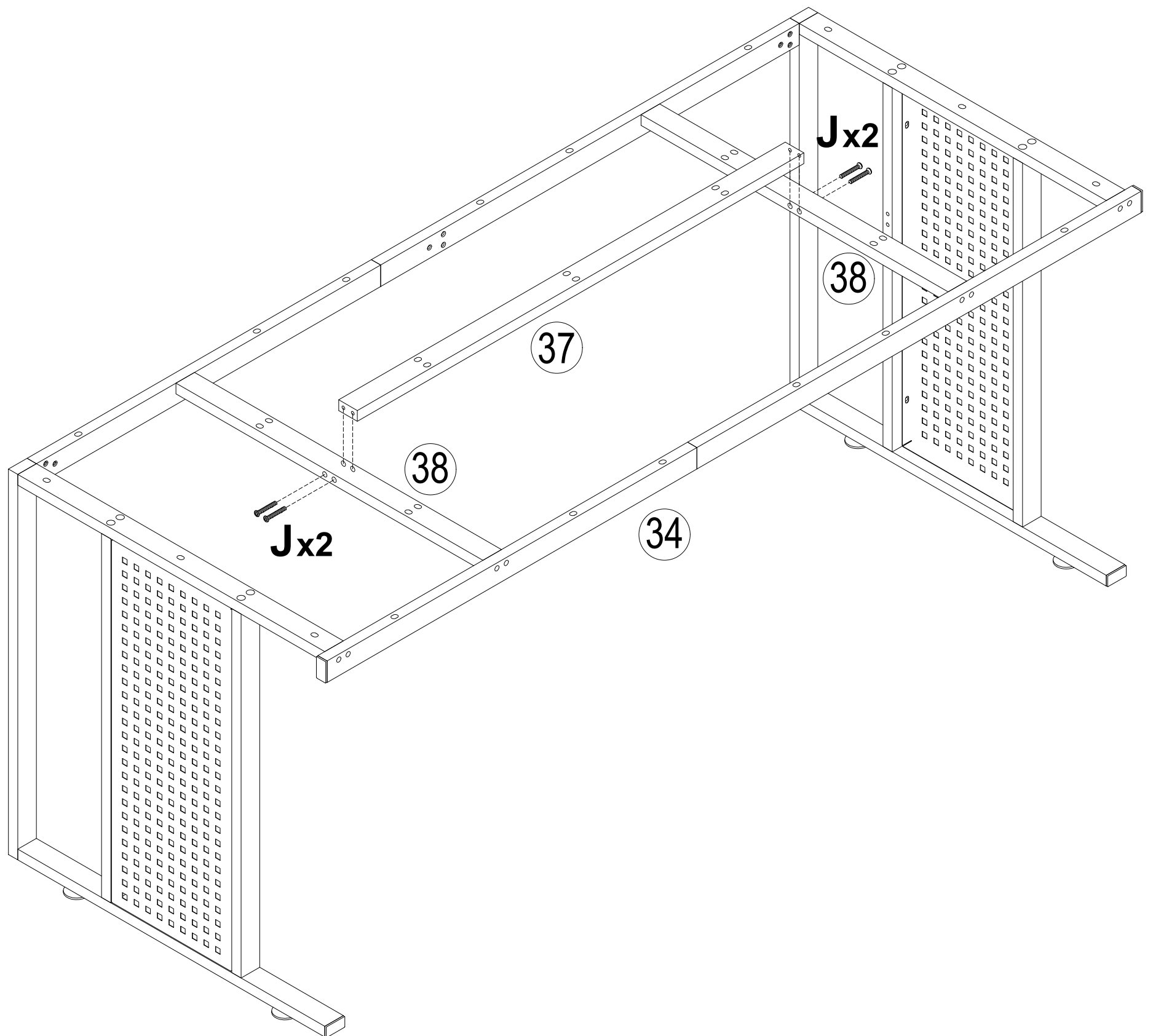

43

C Ø6x40



12 PCS

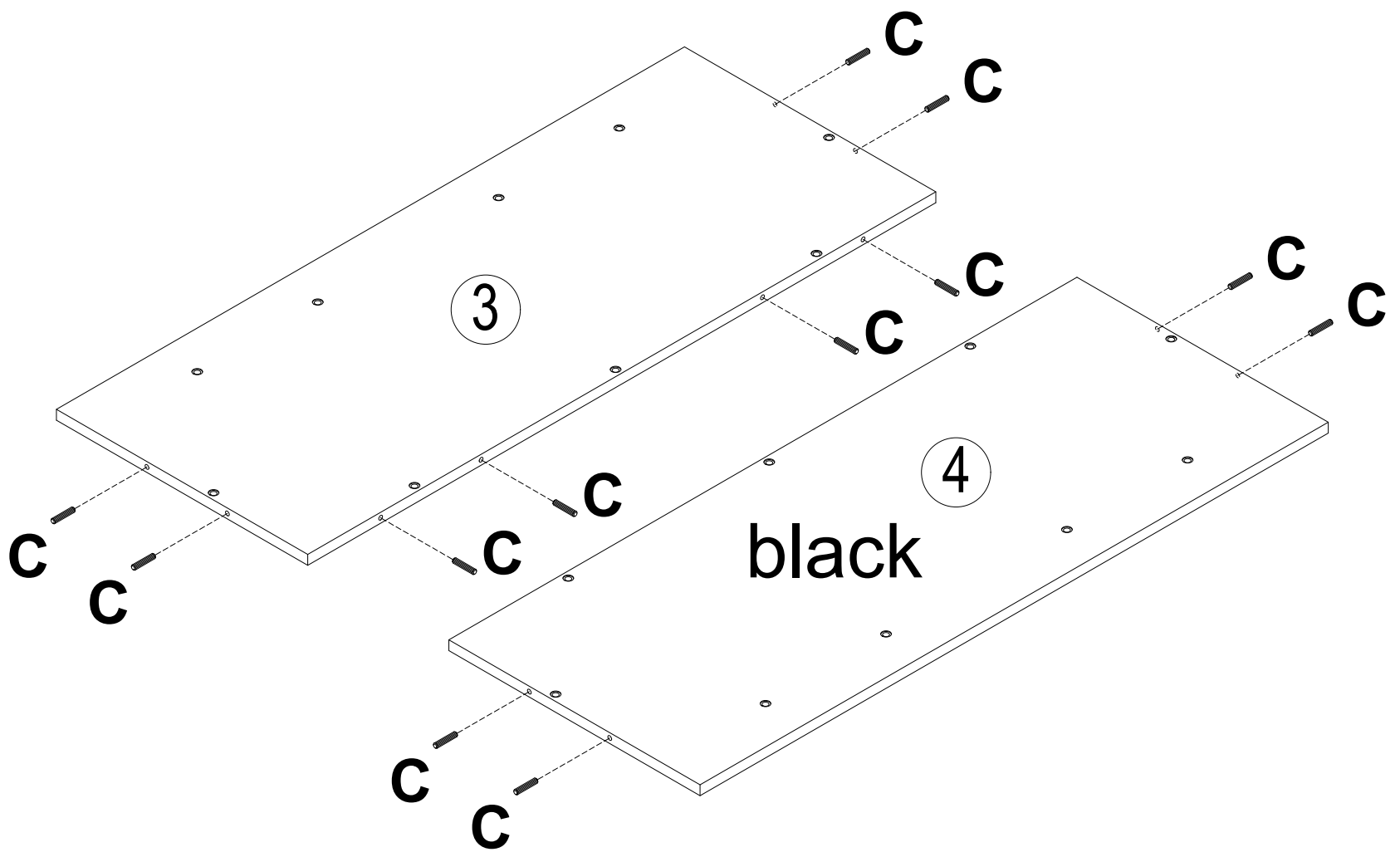

44

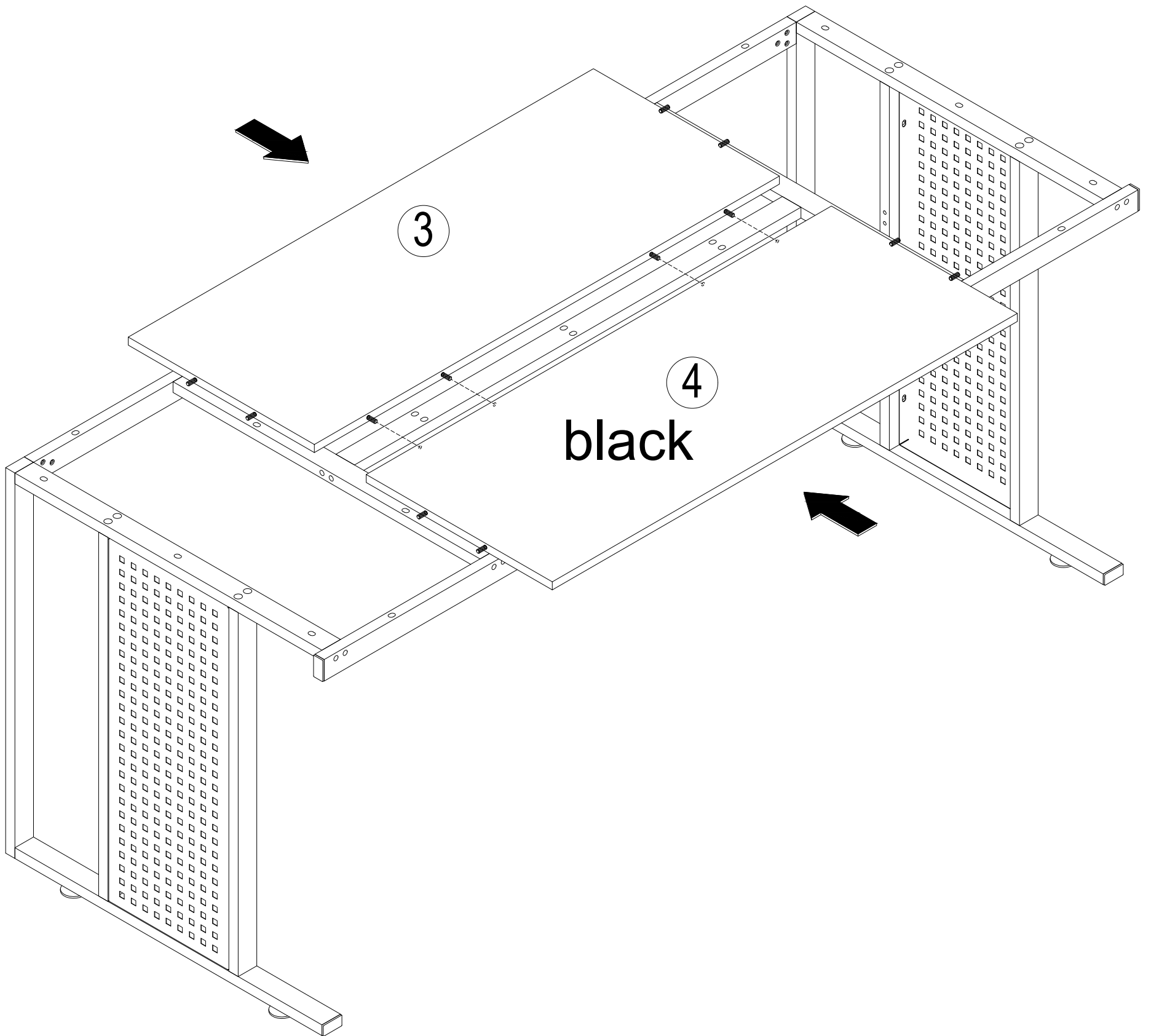

45

K M6X30



10 PCS

M M6X50

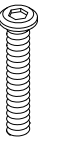

8 PCS

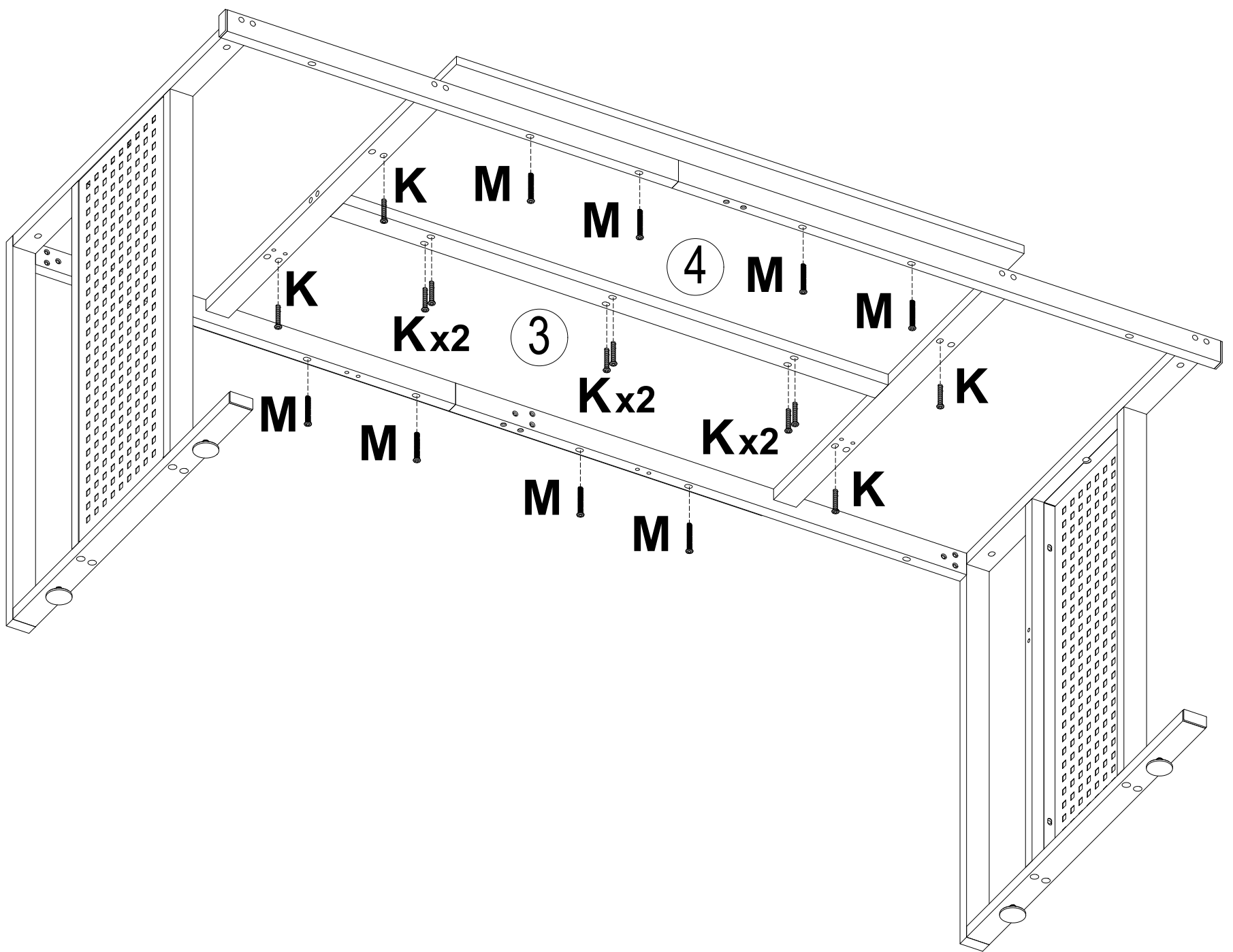

46

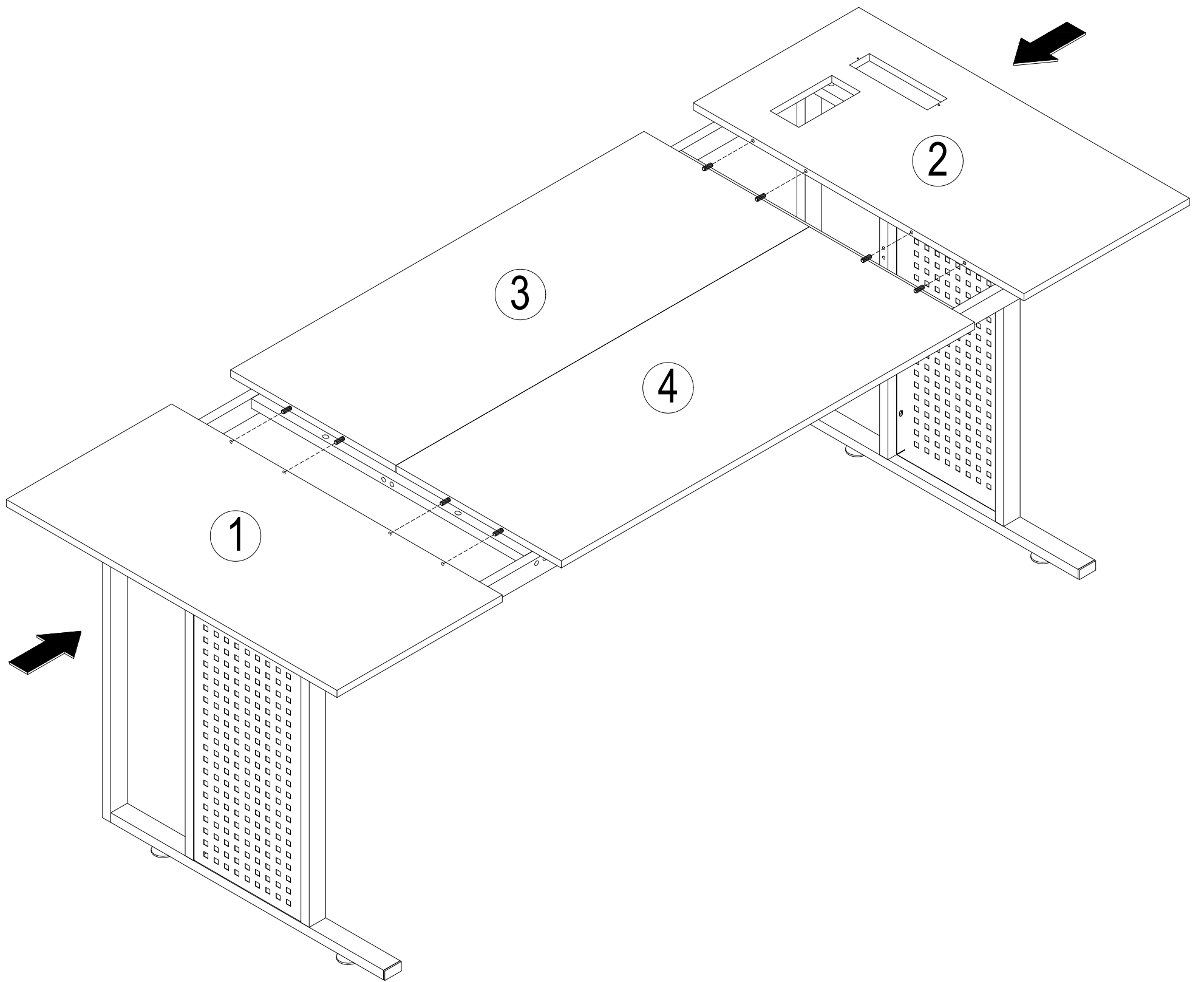

47

K M6X30

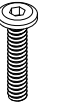

5 PCS

M M6X50

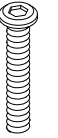

2 PCS

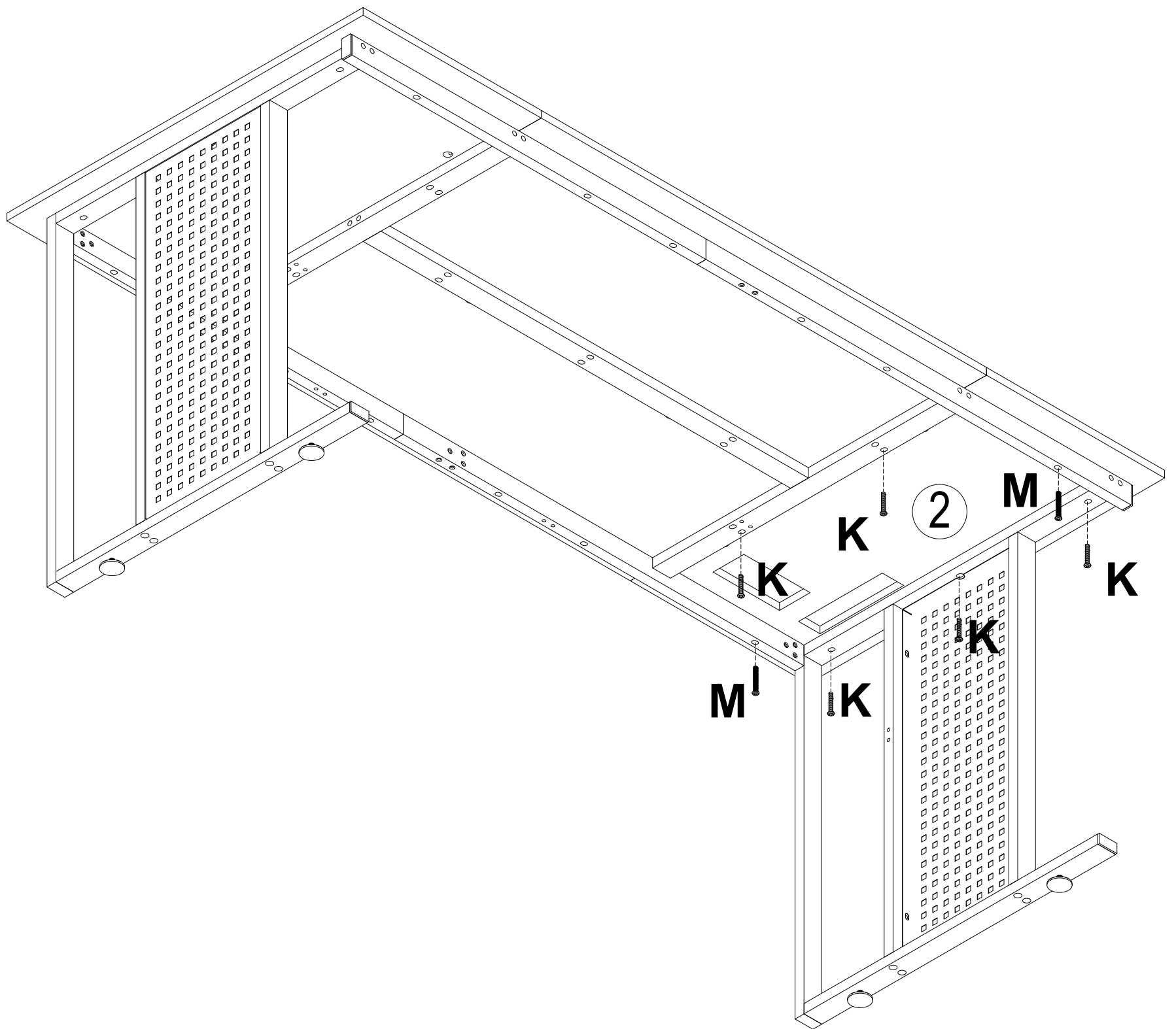

48

K M6X30



5 PCS

M M6X50

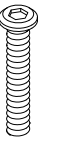

2 PCS

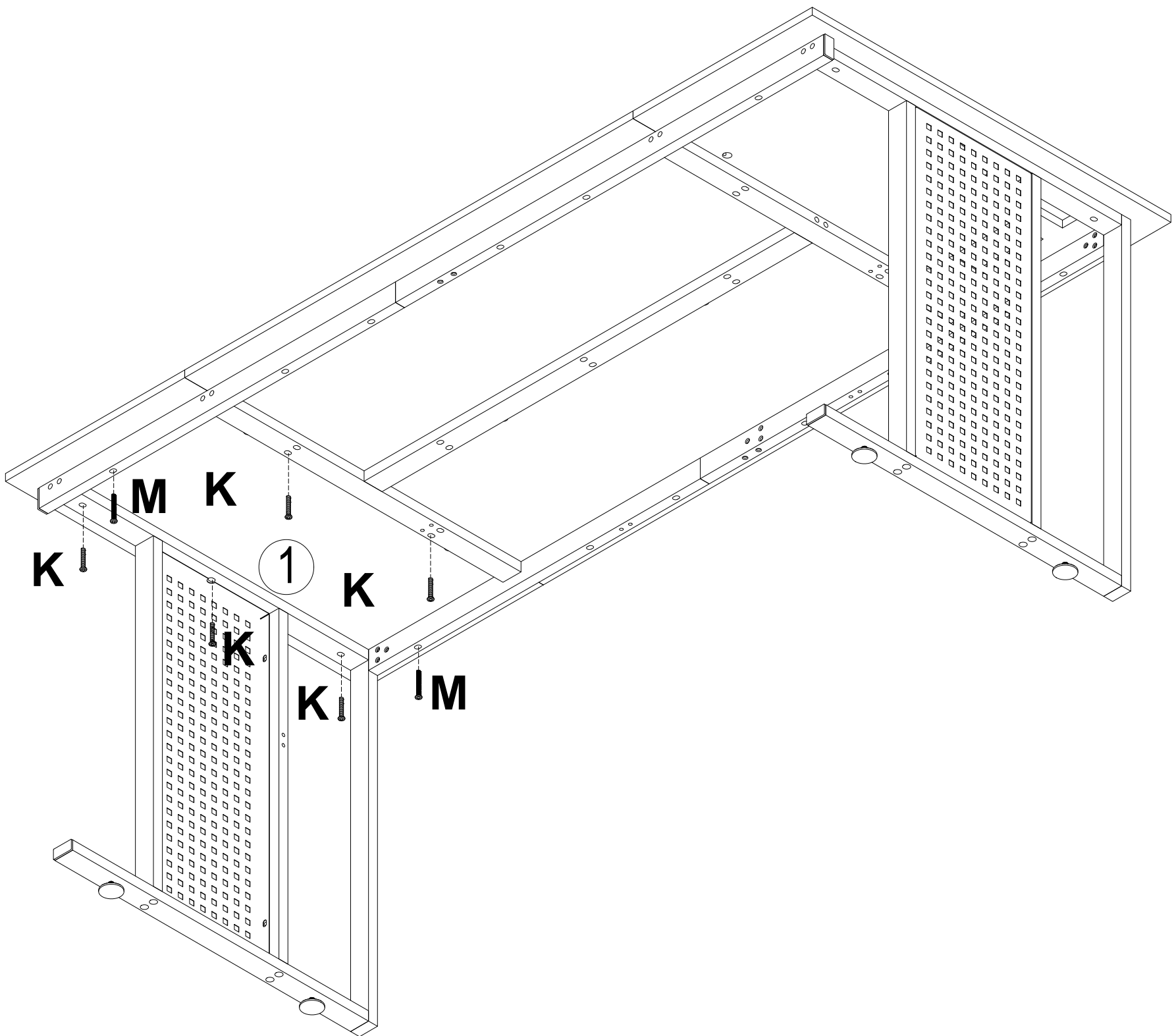

49

K M6X30



4 PCS

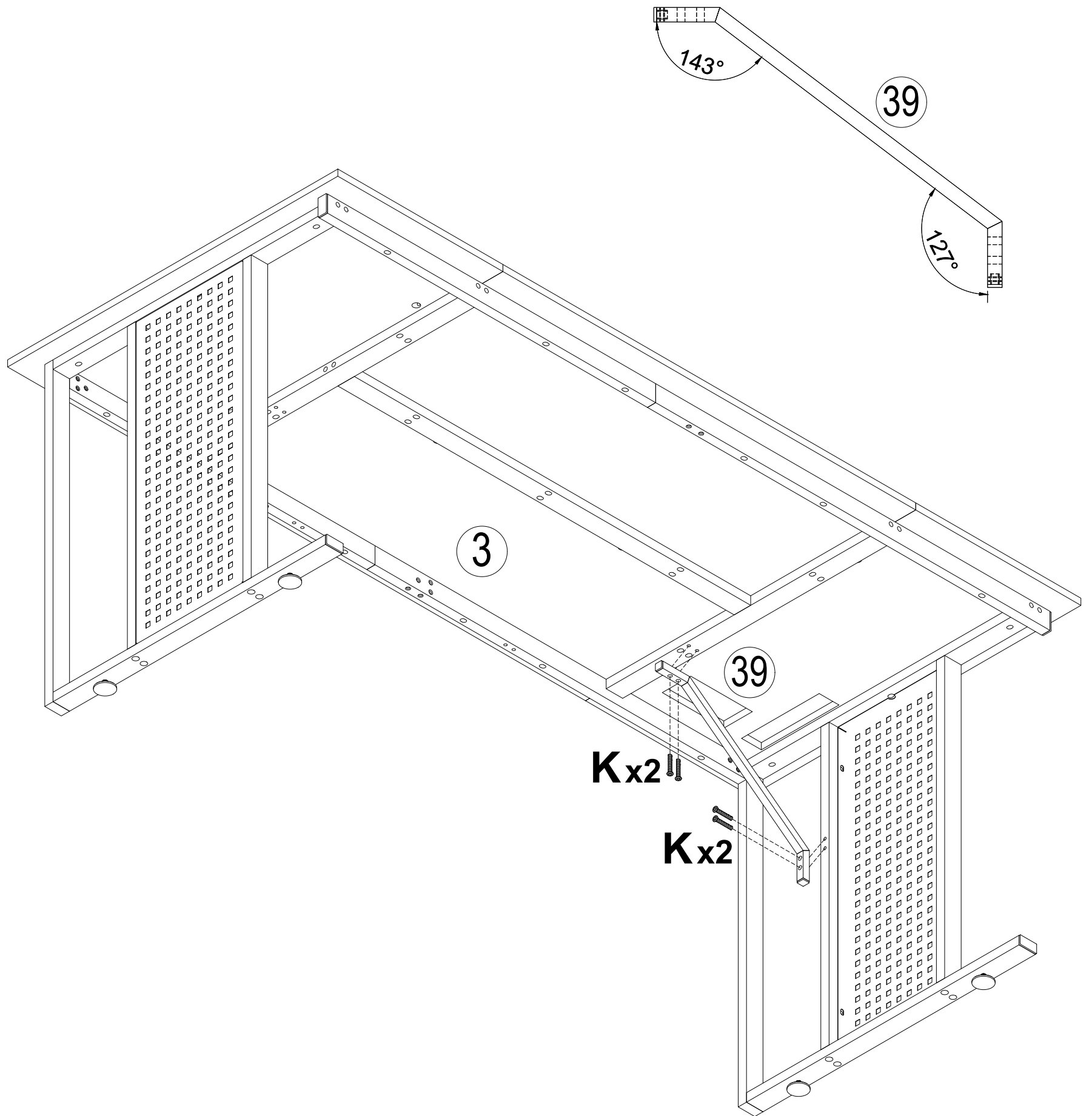

50

K M6X30

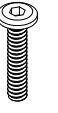

4 PCS

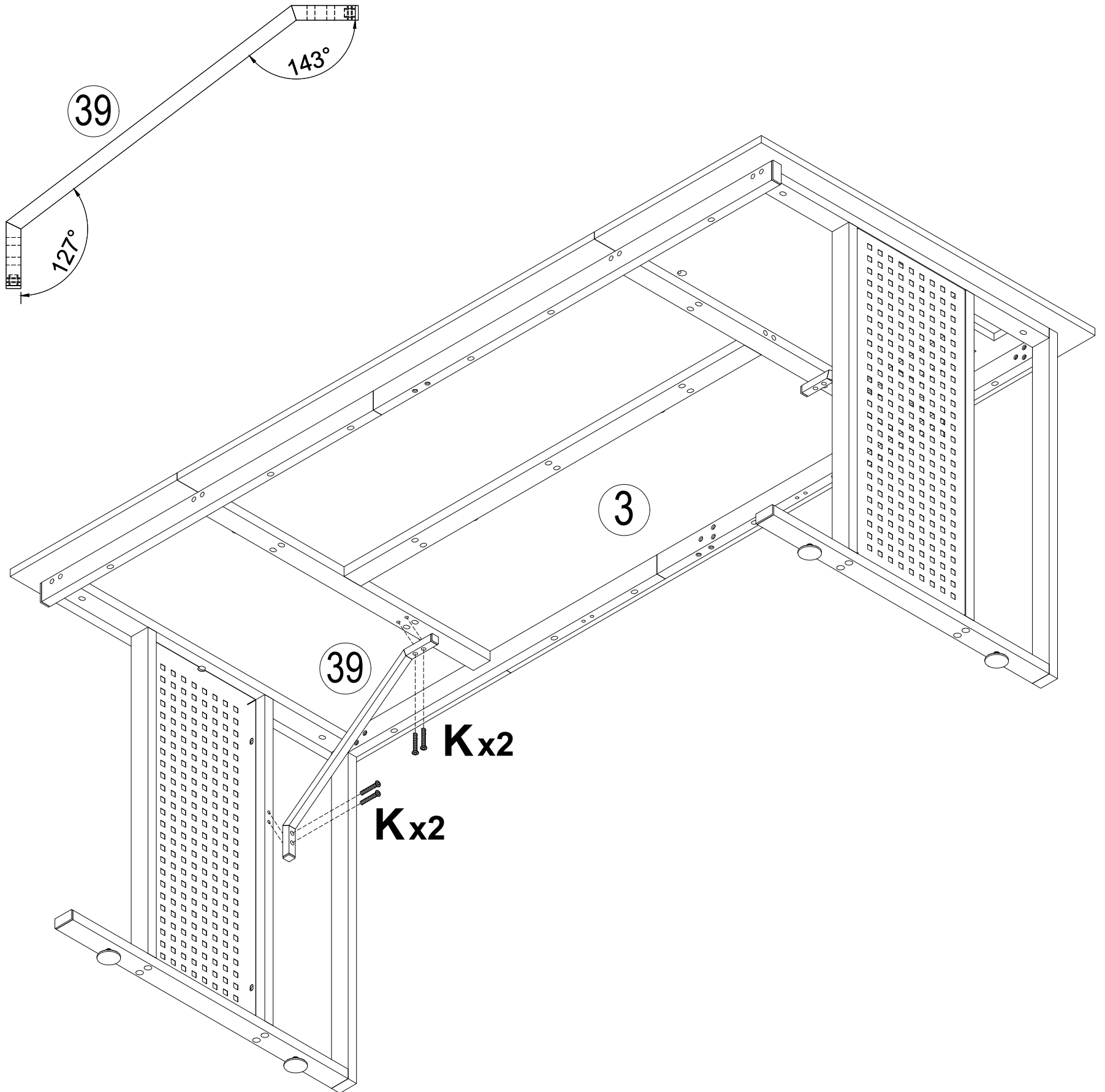

51

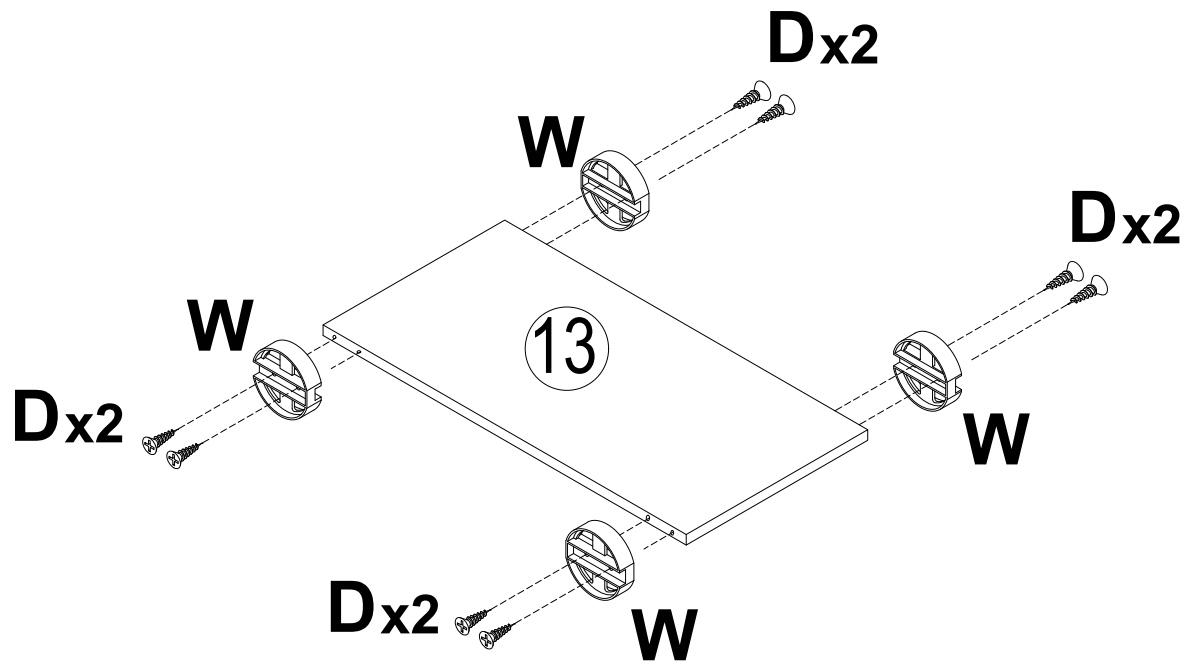

D M3.5X12



8 PCS

W



4 PCS

52

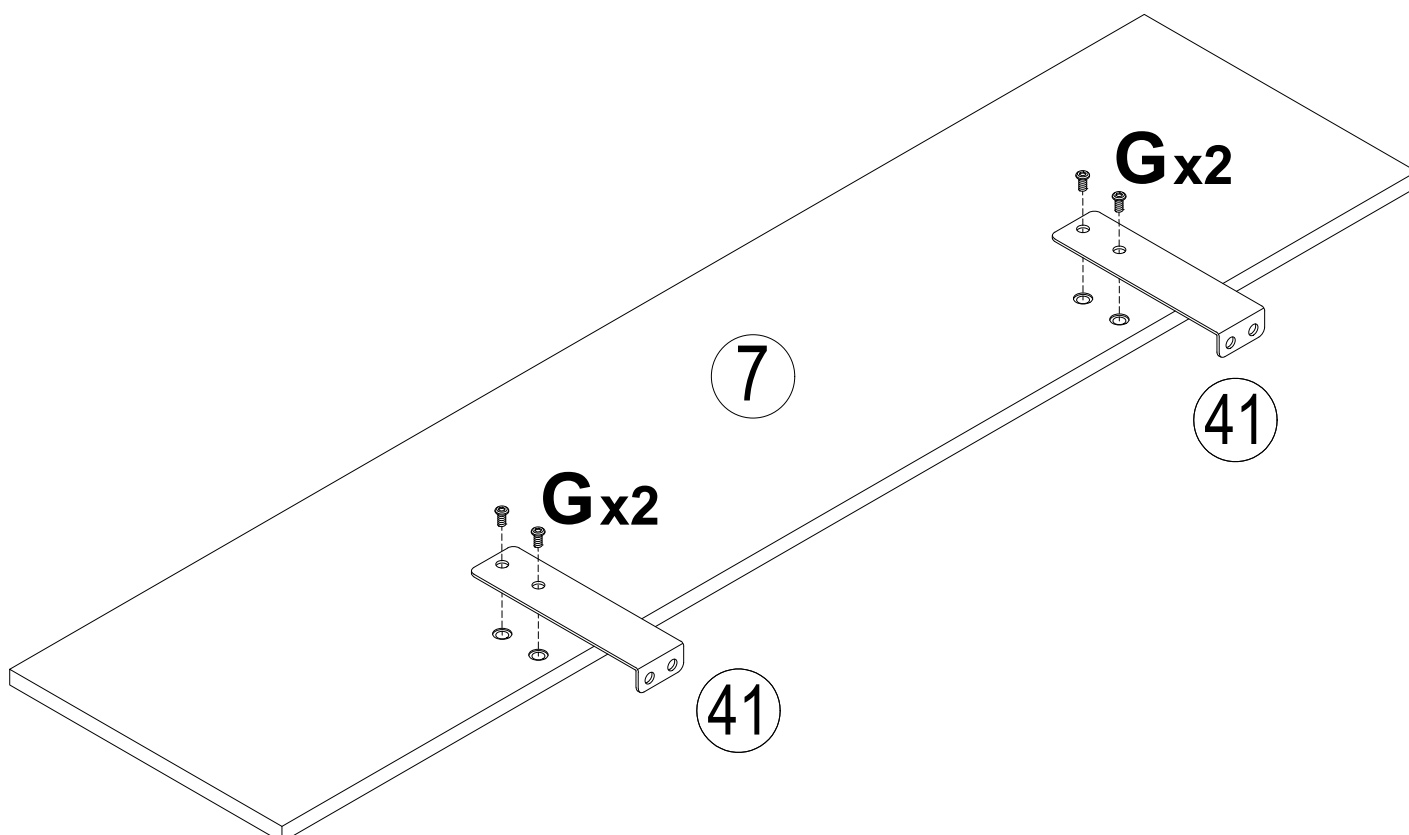

G M6X10



4 PCS

53

G M6X10

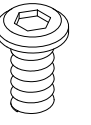

4 PCS

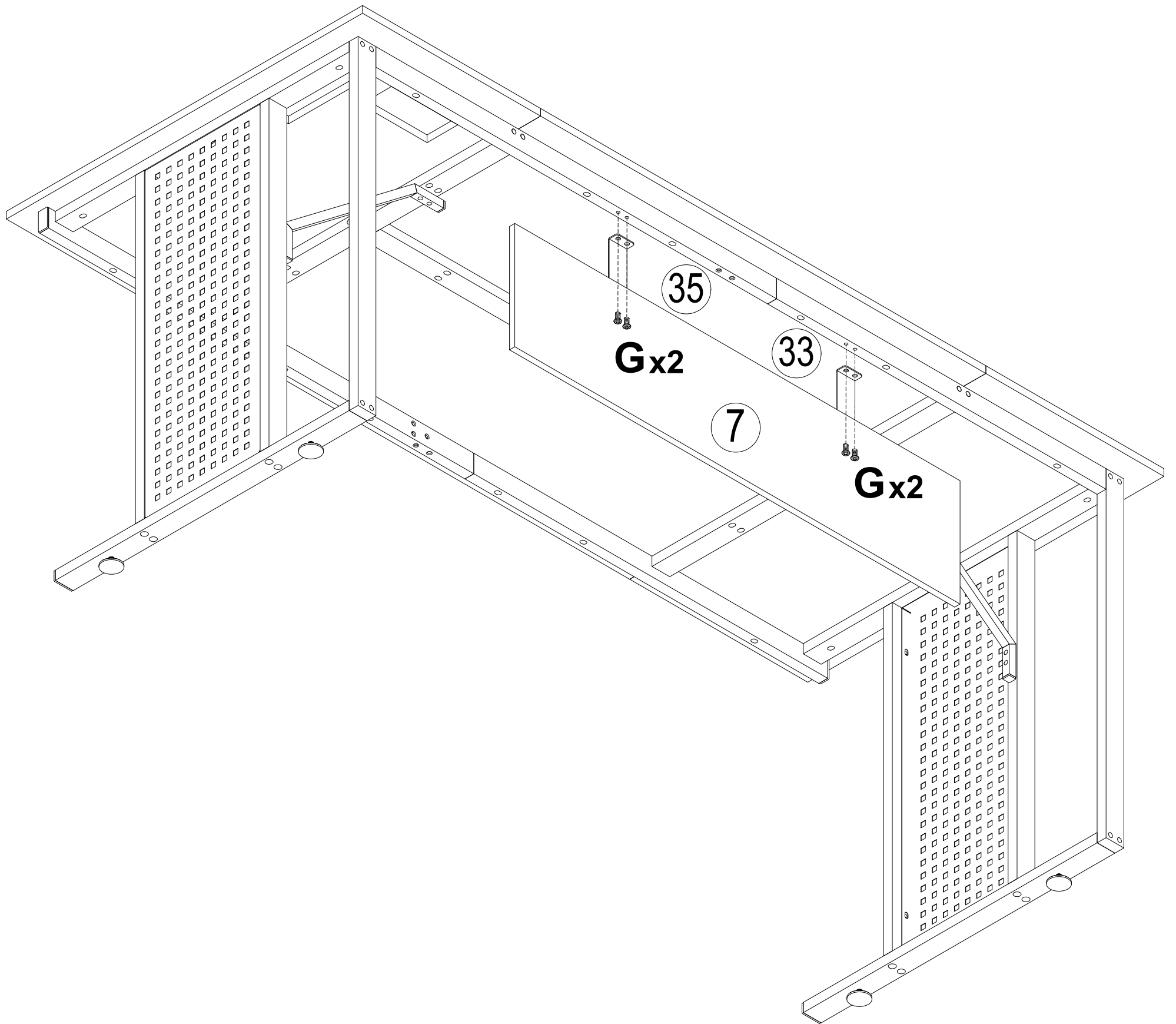

54

Y

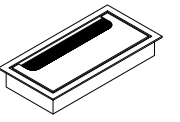

1 PCS

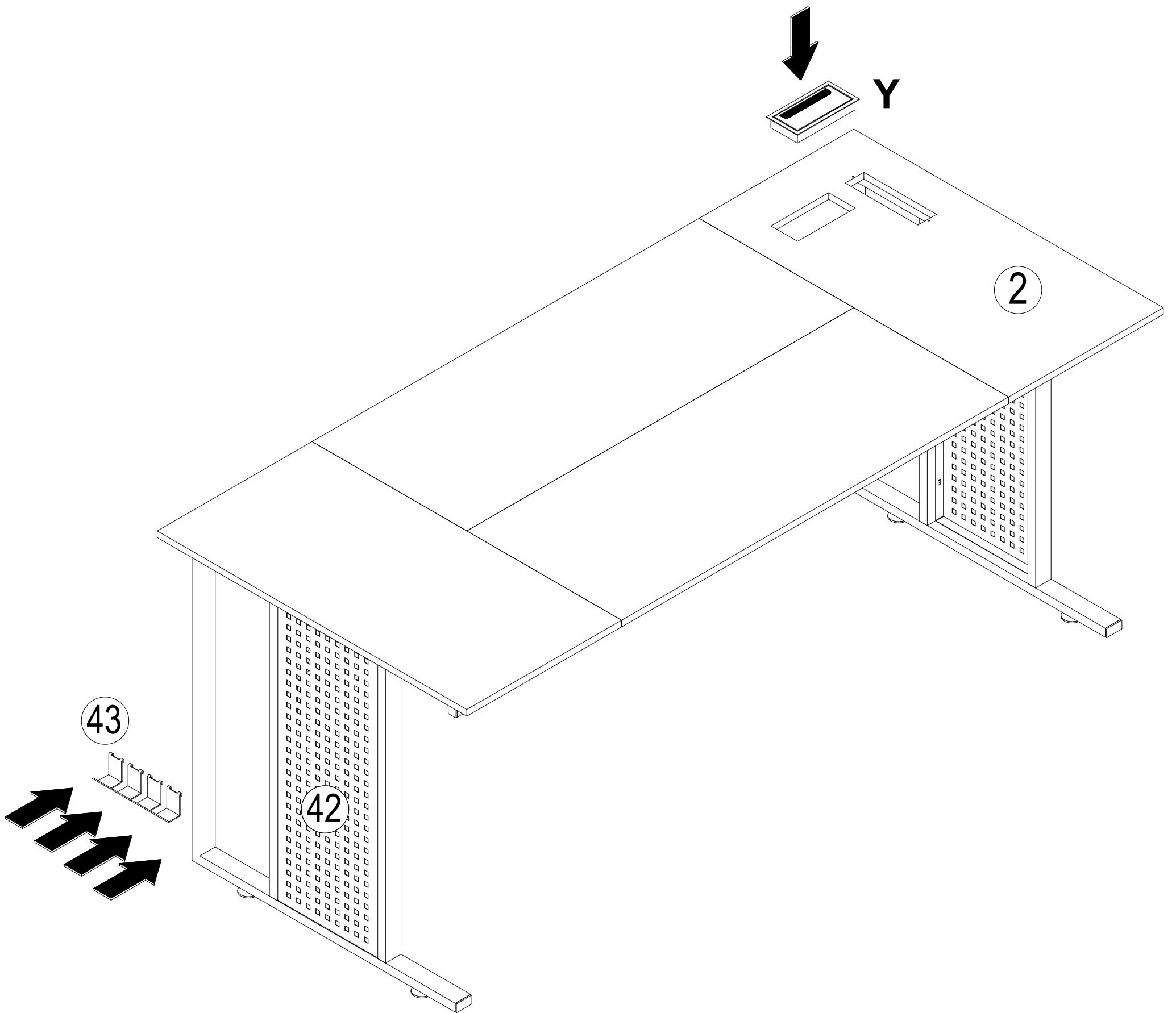

55

D M3.5X12



2 PCS

Z

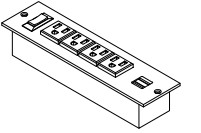

1 PCS

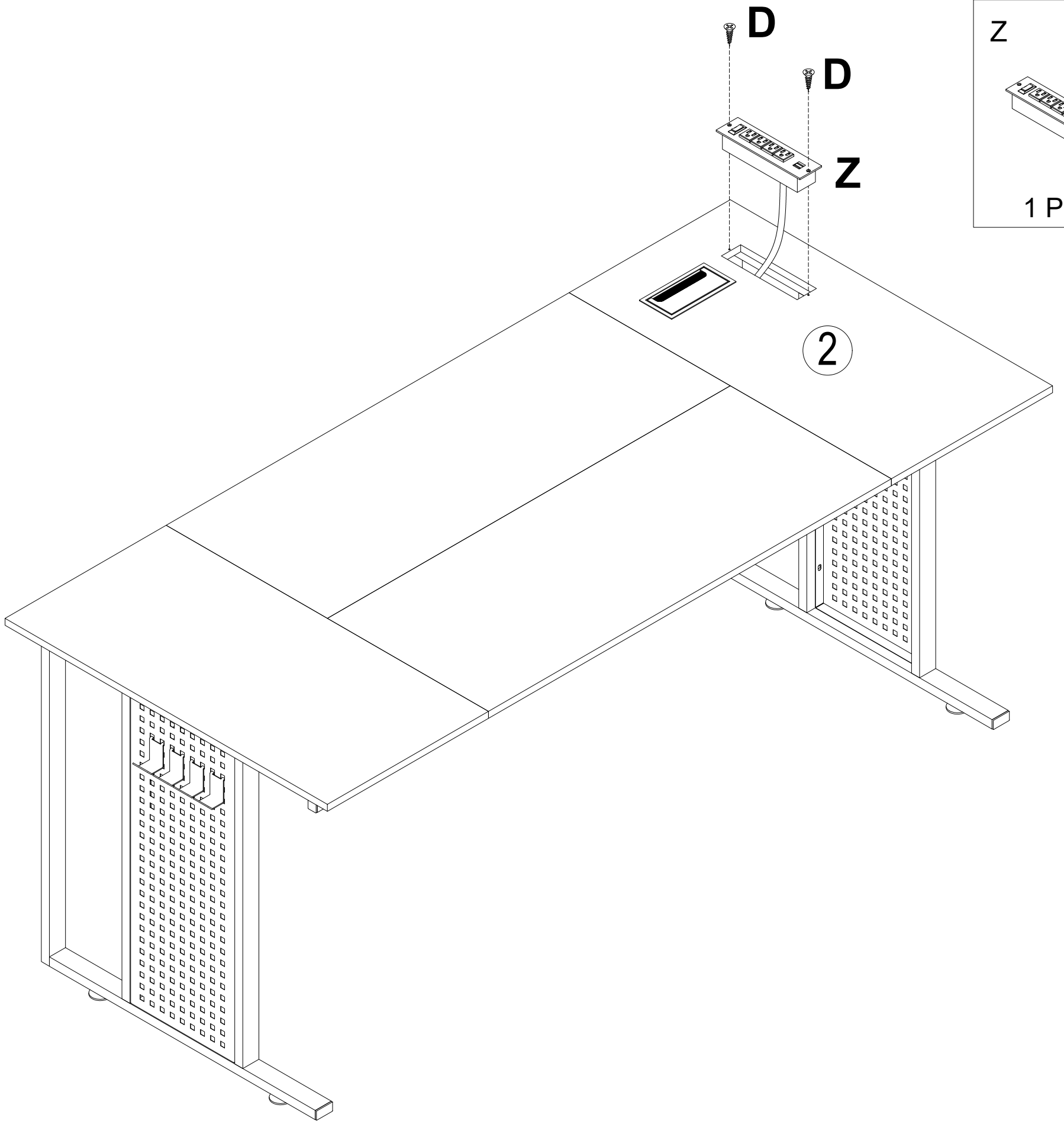

56

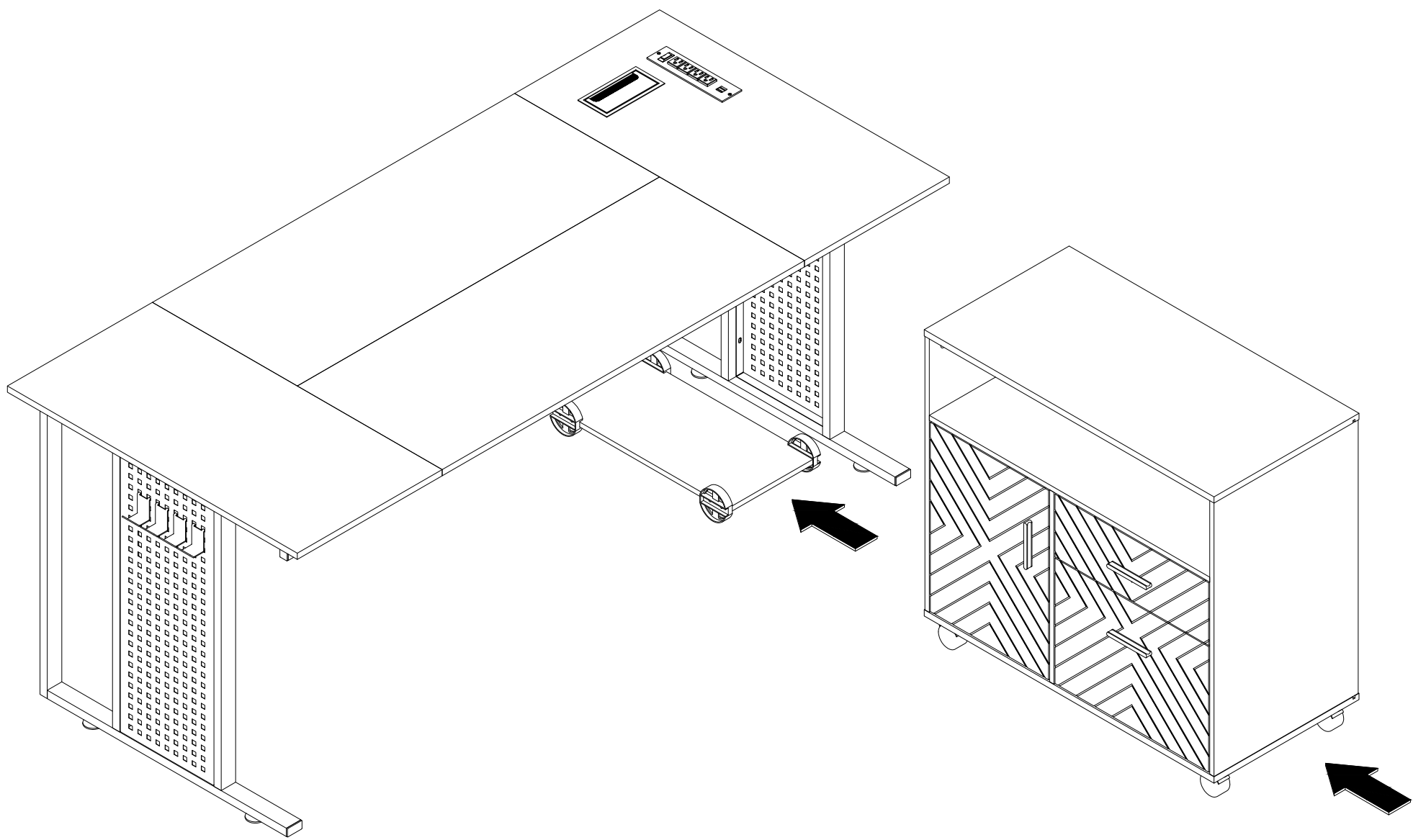

Thank you
for choosing our product