

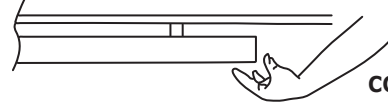

THANK YOU FRO PURCHASING THIS QUALITY PRODUCT. BE SURE TO CHECK ALL PACKING MATERIAL CAREFULLY FOR SMALL PARTS THAT MAY HAVE COME LOOSE INSIDE THE CARTON DURING TRANSIT.

Notice: Not to hold or raise the table from holding the top/extension together. But need to hold the metal frame of the table to raise the table to move to the locations preferred



CORRECT WAY

PART LIST

NO	DESC	SIZE (MM)	SKETCH	QTY
A	TOP	1600*1000*158		1PC
B	LEGS	827*684*150		2PCS
C	CONNECTING PLATE	100*100*6		1PC
D	CONNECTING PLATE	190*190*20		1PC

HARDWARE LIST

NO	DESC	SIZE(MM)	SKETCH	QTY
1	BOLT	M8*20		20PCS
2	ALLEN KEY	5#		1PC
3	SOCKET WRENCH	M6		1PC

Step 1

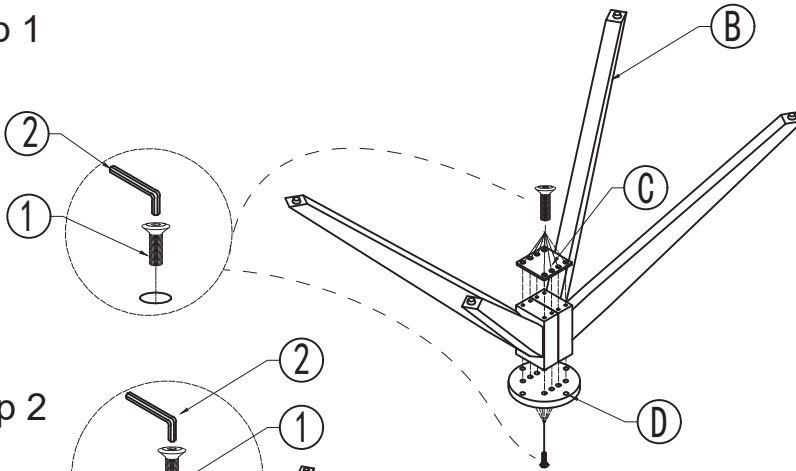

Step 2

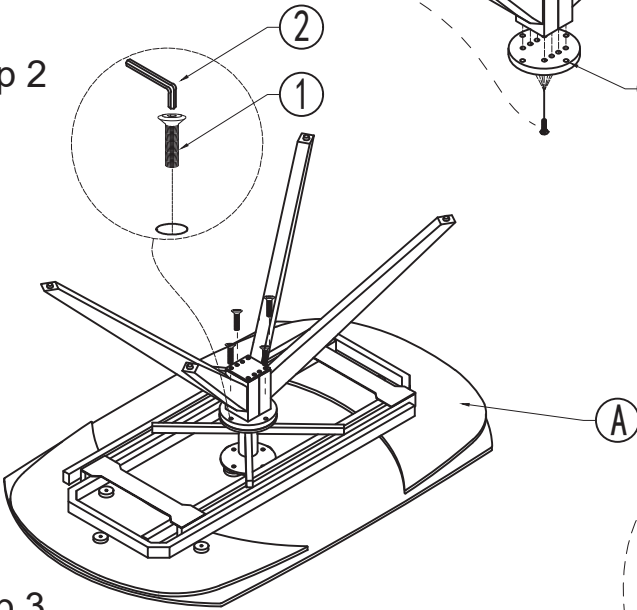

Step 3

Ensure both handles at unlock positions, then proceed to swivel the table top

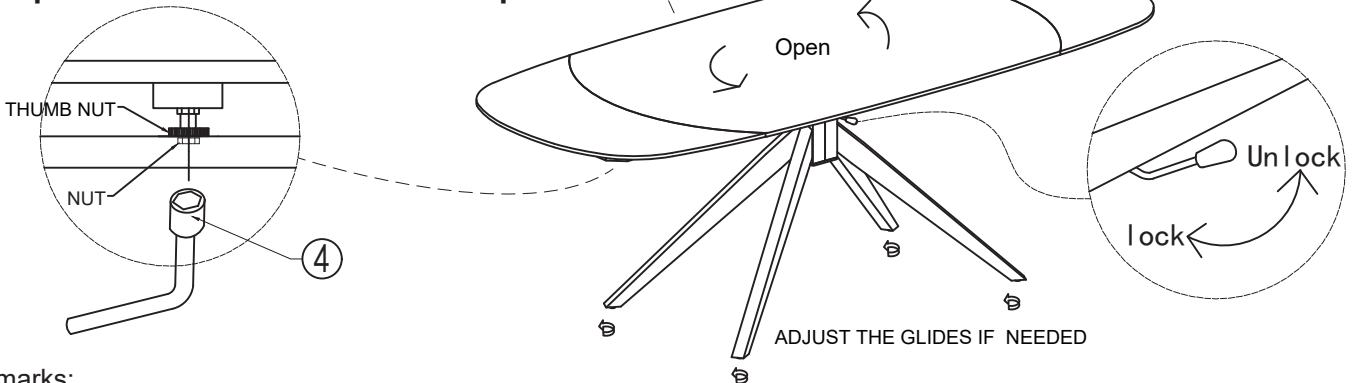

Remarks:

In case the table tops are not leveled, Using the wrench supplied (part 4) loosen the nut under the track, and adjust the height by turning the thumb nut. Turn clockwise to raise the leaf and anti clockwise to lower the leaf position. Once the table top is level re tighten the nut under the track.

FINISHED