

Entertainment Center

Assembly Instructions

Please keep for future reference



Important - Please read these instructions fully before starting assembly

Safety and Care Advice

Important – Please read these instructions fully before starting assembly

- Check you have all the components and tools listed on the following pages.
- Remove all fittings from the plastic bags and separate them into their groups.
- Keep children and animals away from the work area, small parts could choke if swallowed.
- Make sure you have enough space to layout the parts before starting.

- During assembly do not stand or put weight on the product, this could cause damage.
- Assemble the item as close to its final position (in the same room) as possible.
- Assemble on a soft level surface to avoid damaging the unit or your floor.
- Parts of the assembly will be easier with 2 people.



- To reduce the likelihood of damaging your product please ensure that your power drill is set on a low torque setting.

• Only clean using a damp cloth and mild detergent, do not use bleach or abrasive cleaners.

• From time to time check that there are no loose screws on this unit.

• This product should not be discarded with household waste. Take to your local authority waste disposal centre.

• Assemble all parts and bolts loosely during assembly, only once the product is complete should you fully tighten the bolts

• Regularly check and ensure That all bolts and fittings are tightend properly.

WARNING In order to help prevent overturning – please follow these instructions

To help prevent product toppling over please follow the below steps:-

Use the anti tip stap or wall fixing method provided (if applicable)
Do not allow children to climb or hang on the furniture
Do not open more than one drawer at a time
Do not place heavy items in the top drawers
Do not place heavy items on top of the furniture, unless the furniture has been designed for this purpose

Using Camlocks

Step 1

Connect the male camlock as directed in the assembly instructions using a screwdriver.

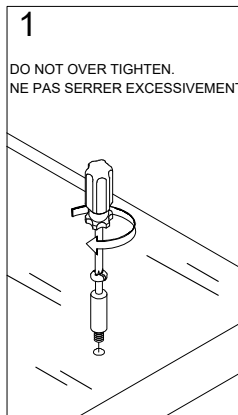

Step 2

Push the male camlock into the entry hole.

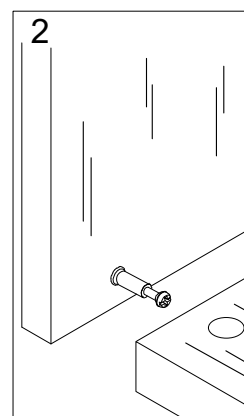

Step 3

Insert the female camlock as shown in the instruction.

Note: ensure that the arrow on the top of the camlock points towards the entry hole for the male camlock.

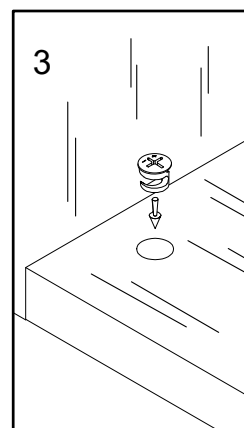

Step 4

Turn the female camlock clockwise with a screwdriver.

You should feel a click when the camlock is locked in place.



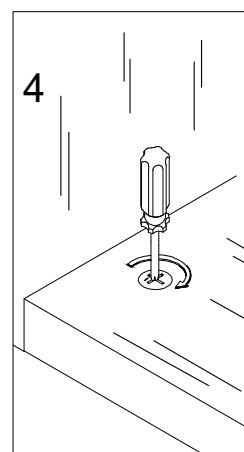

The joint is now secure.

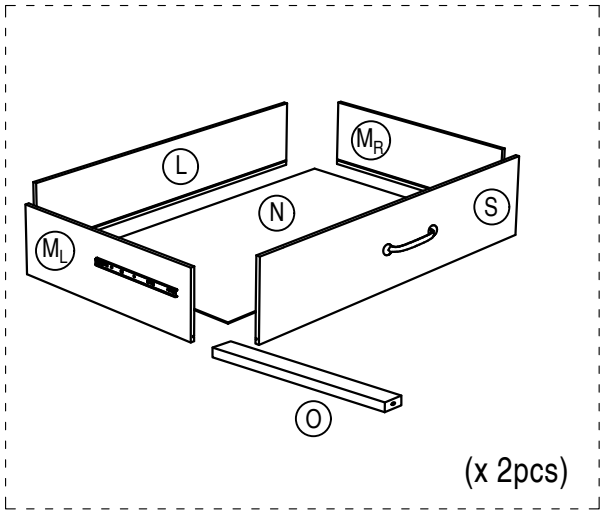
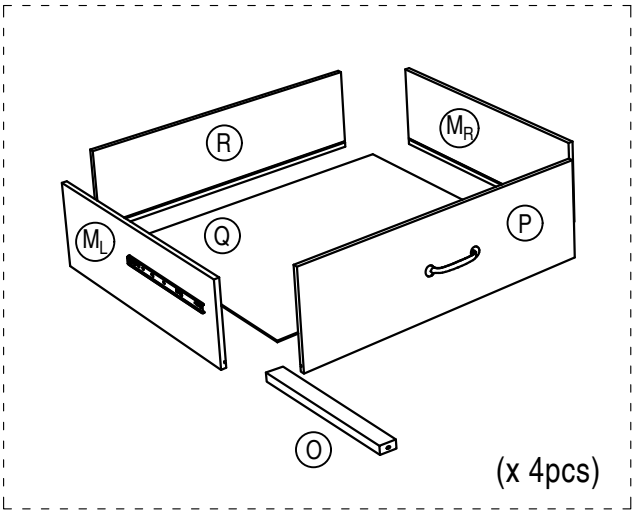
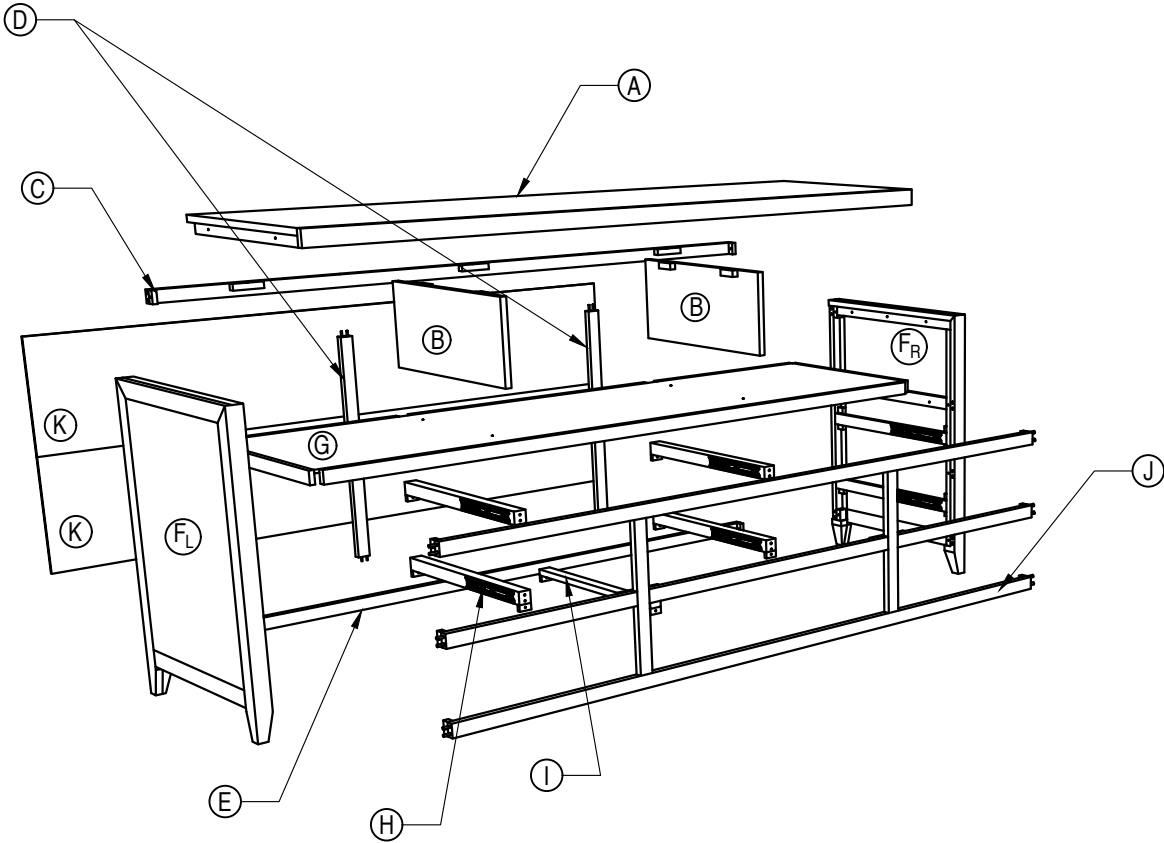

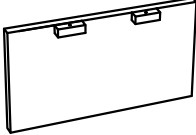
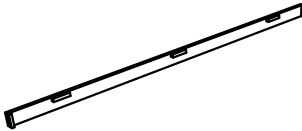

COMPONENTS - KEY DIAGRAM

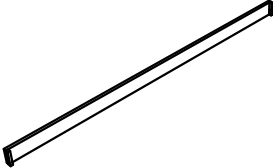
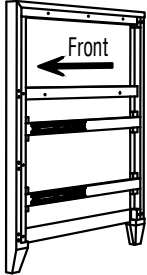
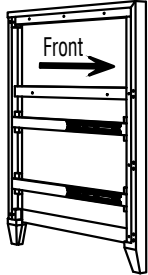
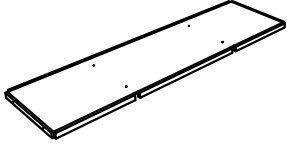

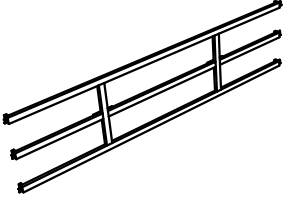
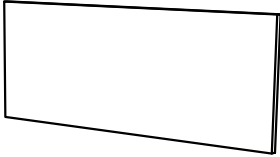



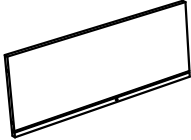
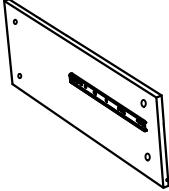
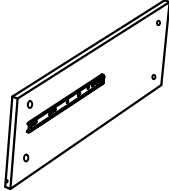
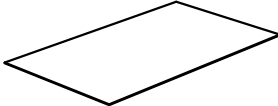

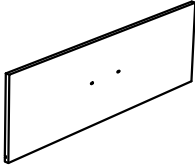
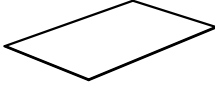
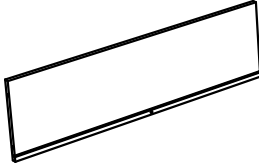
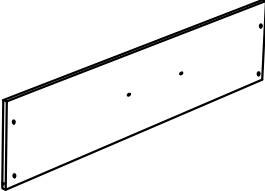



Part List

<p>(A)</p>	<p>(B)</p>	<p>(C)</p>	<p>(D)</p>
			
<p>Quantity: 1 pc</p>	<p>Quantity: 2 pcs</p>	<p>Quantity: 1 pc</p>	<p>Quantity: 2 pcs</p>
<p>(E)</p>	<p>(F_L)</p>	<p>(F_R)</p>	<p>(G)</p>
			
<p>Quantity: 1 pc</p>	<p>Quantity: 1 pc</p>	<p>Quantity: 1 pc</p>	<p>Quantity: 1 pc</p>
<p>(H)</p>	<p>(I)</p>	<p>(J)</p>	<p>(K)</p>
			
<p>Quantity: 4 pcs</p>	<p>Quantity: 1 pc</p>	<p>Quantity: 1 pc</p>	<p>Quantity: 2 pcs</p>

Part List

<p>(L)</p> 	<p>(M_L)</p> 	<p>(M_R)</p> 	<p>(N)</p> 
<p>Quantity: 2 pcs</p>	<p>Quantity: 6 pcs</p>	<p>Quantity: 6 pcs</p>	<p>Quantity: 2 pcs</p>
<p>(O)</p> 	<p>(P)</p> 	<p>(Q)</p> 	<p>(R)</p> 
<p>Quantity: 6 pcs</p>	<p>Quantity: 4 pcs</p>	<p>Quantity: 4 pcs</p>	<p>Quantity: 4 pcs</p>
<p>(S)</p> 			
<p>Quantity: 2 pcs</p>			

Hardware List

①	②	③	④
			
<p>Allen key Quantity: 1 pc</p>	<p>6x30mm Quantity: 35 pcs</p>	<p>6x16mm Quantity: 35 pcs</p>	<p>8x30mm Quantity: 24 pcs</p>
⑤a	⑤b	⑥	⑦
			
<p>Cam bolt Quantity: 36 pcs</p>	<p>Cam lock Quantity: 36 pcs</p>	<p>4x20mm Quantity: 12 pcs</p>	<p>4x30mm Quantity: 38 pcs</p>
⑧	⑨	⑩	
			
<p>3x15mm Quantity: 36 pcs</p>	<p>Handle Quantity: 6 pcs</p>	<p>Screwdrivers Quantity: 1 pc</p>	

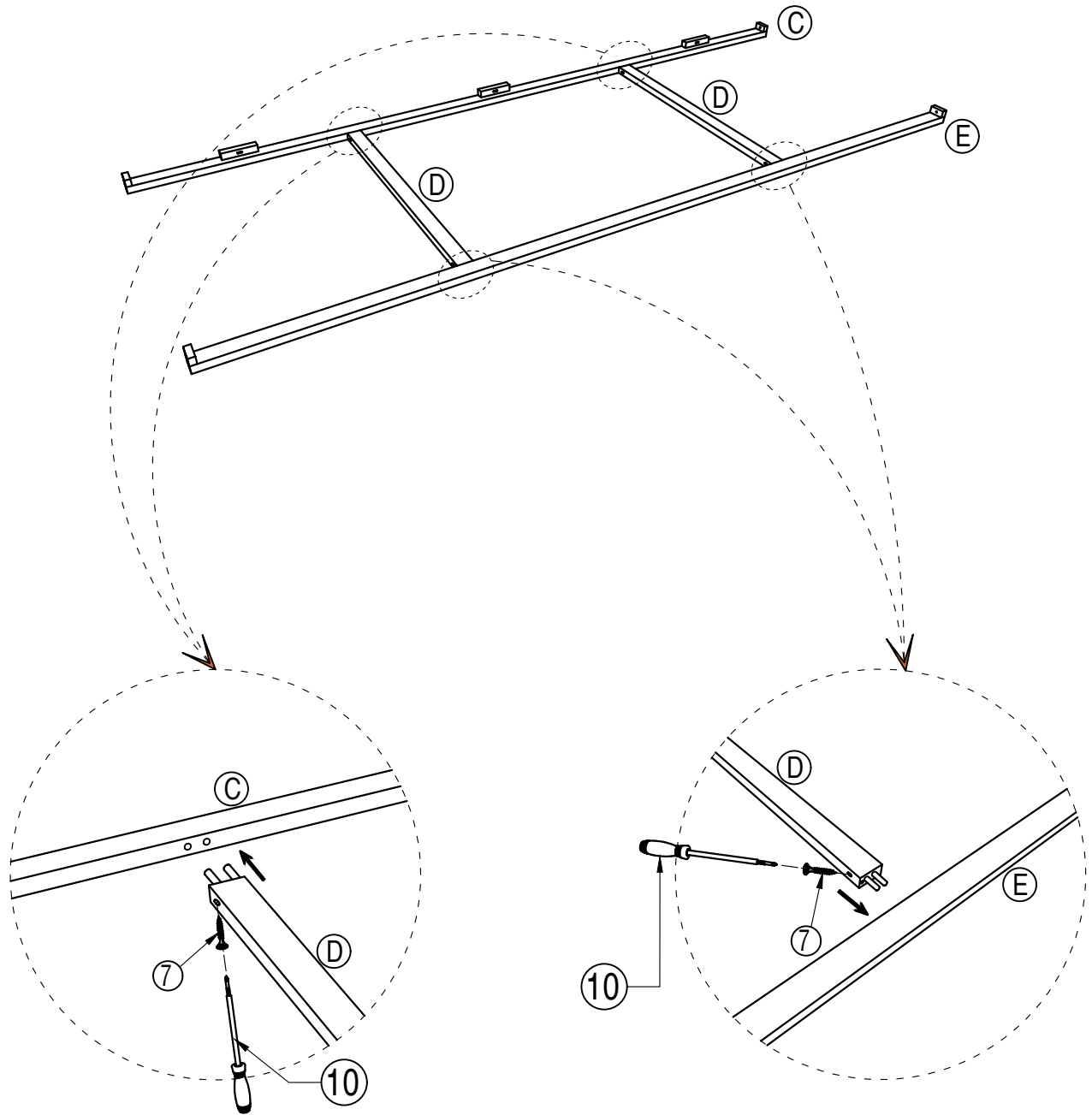

STEP 1

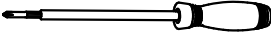

⑦	⑩
 4x30mm 4 pcs	

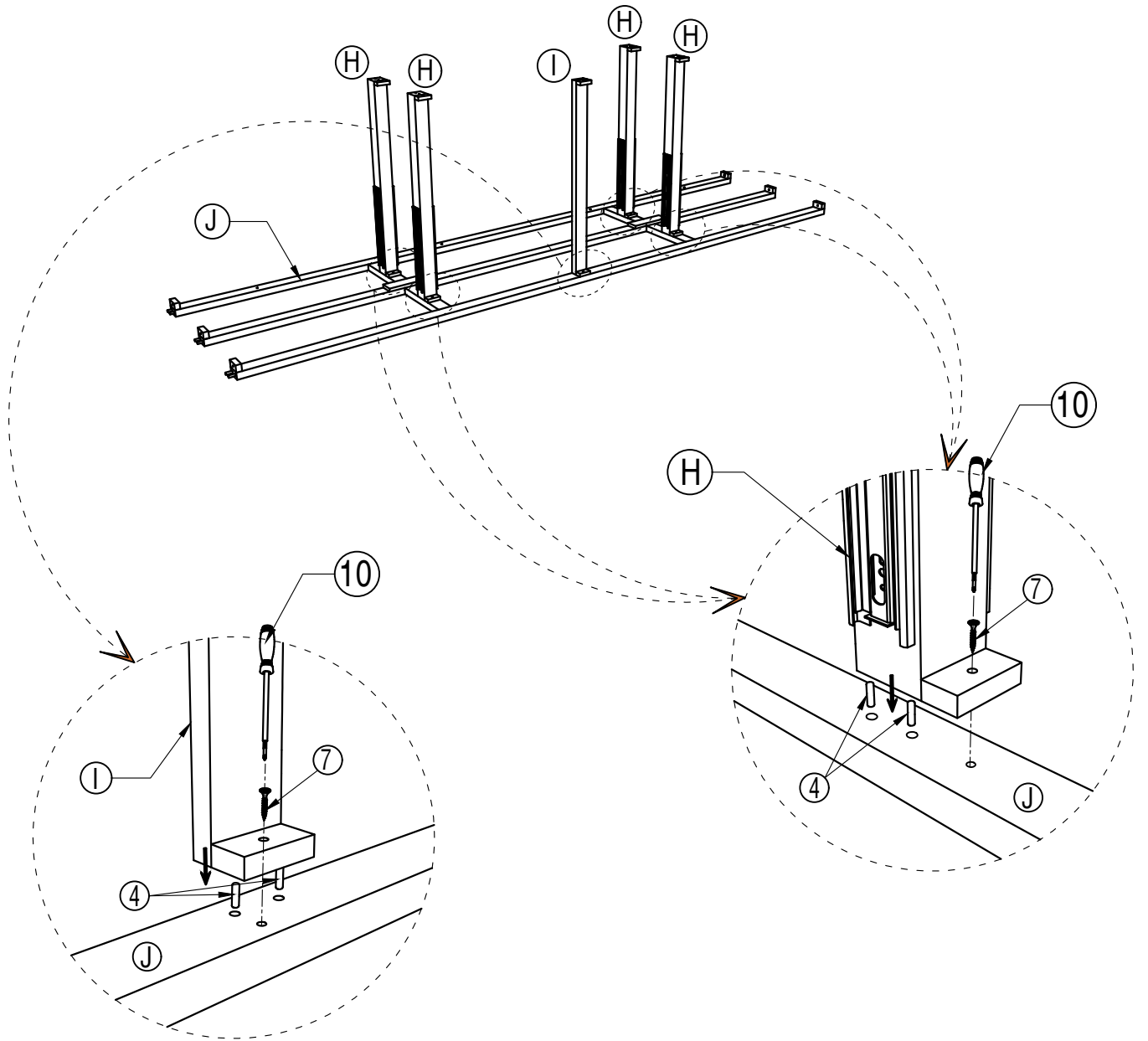
STEP 2

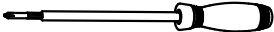

④	⑦	⑩
 8x30mm 10 pcs	 4x30mm 5 pcs	



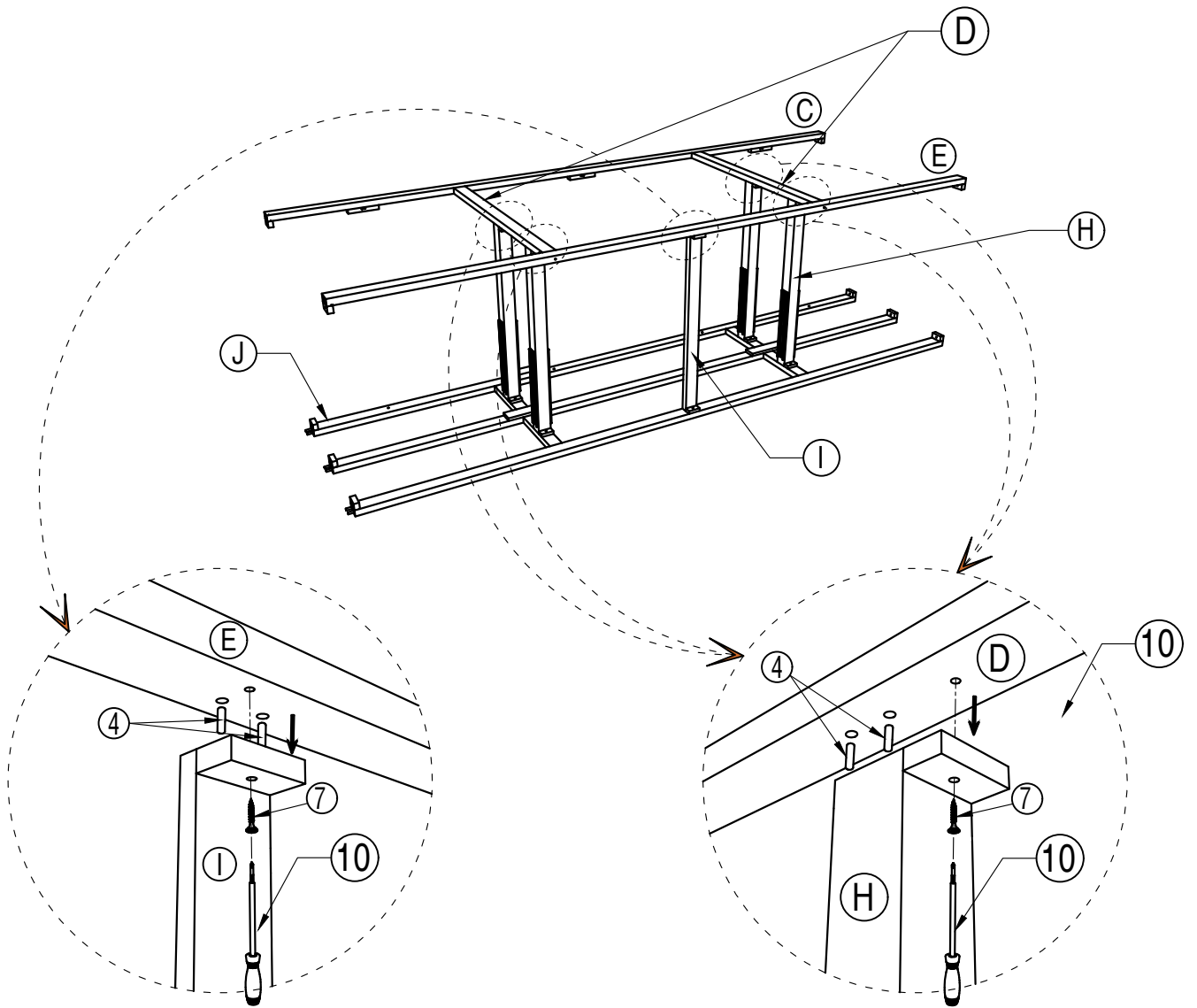

STEP 3

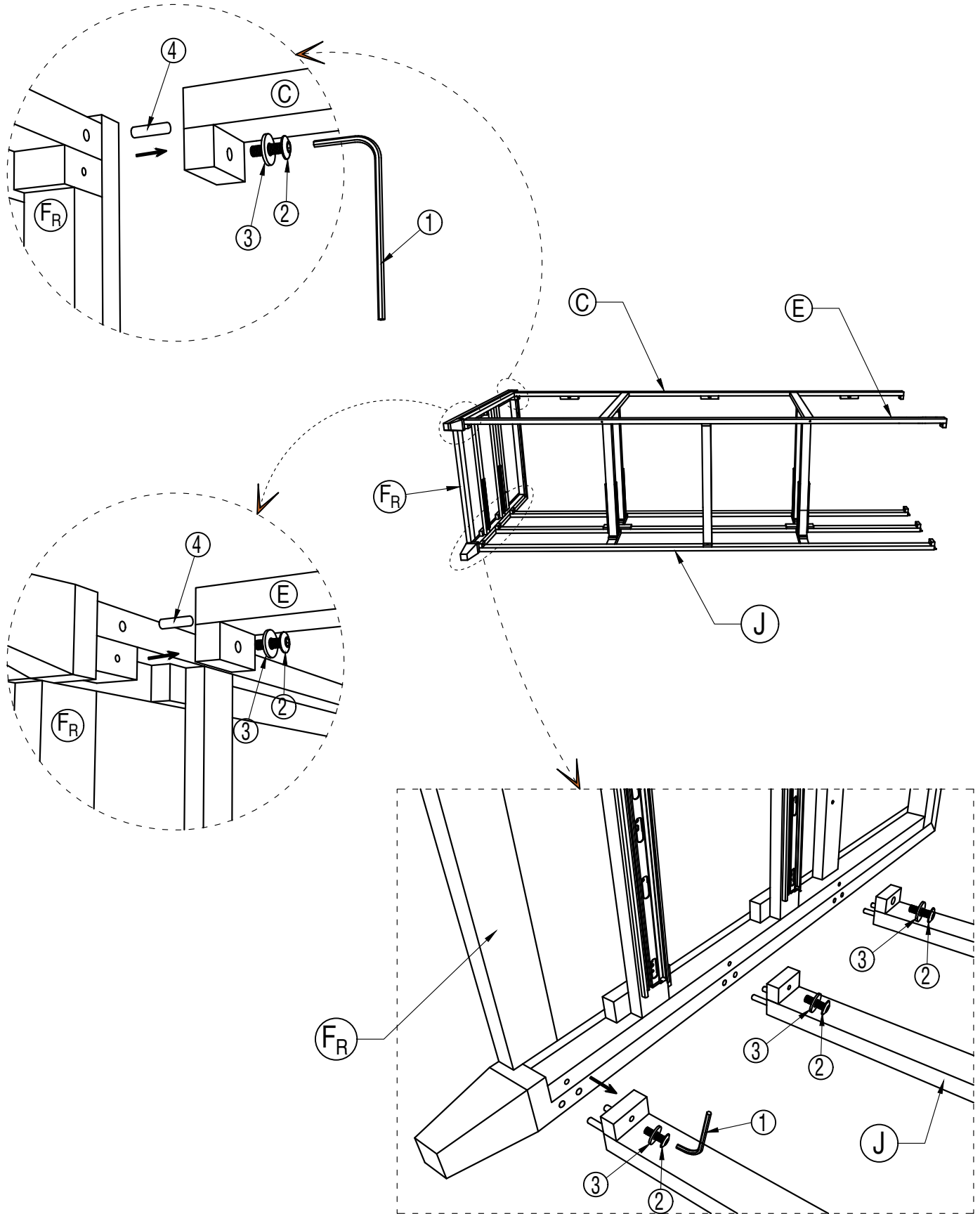

④	⑦	⑩
 8x30mm 10 pcs	 4x30mm 5 pcs	





STEP 4

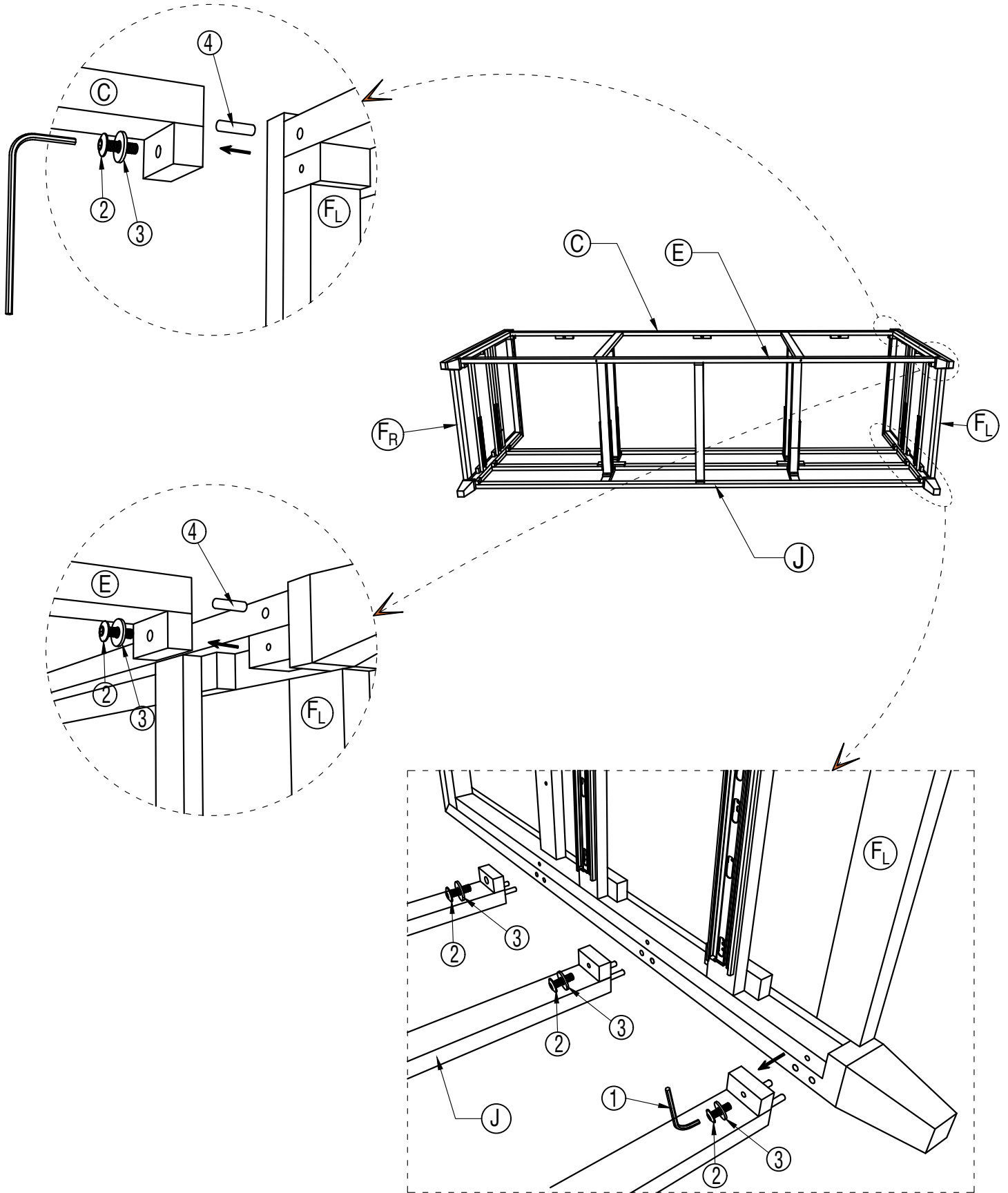

①	②	③	④
			
	6x30mm 5 pcs	6x16mm 5 pcs	8x30mm 2 pcs



STEP 5



①	②	③	④
			
	6x30mm 5 pcs	6x16mm 5 pcs	8x30mm 2 pcs

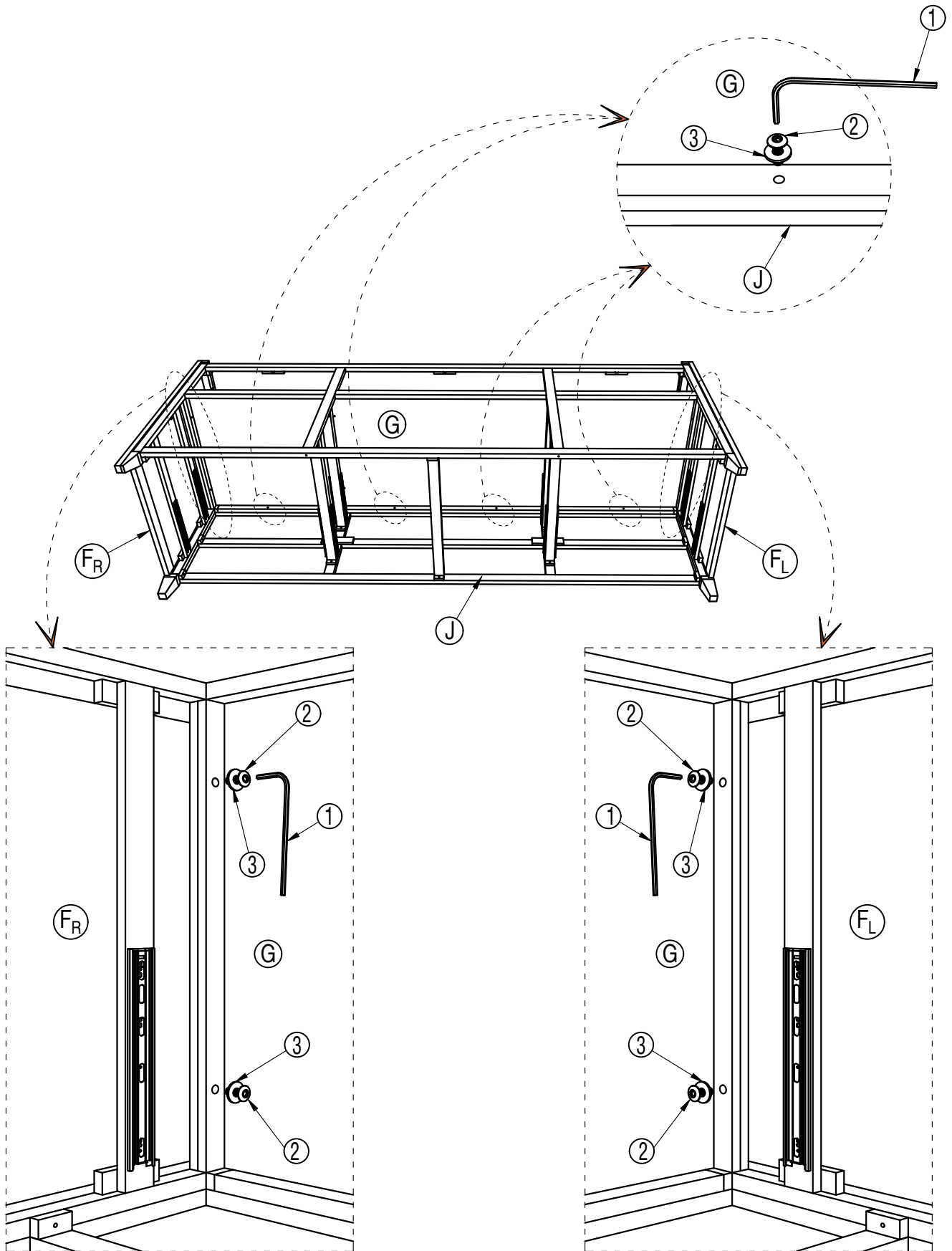

STEP 6



①	②	③
	 6x30mm 8 pcs	 6x16mm 8 pcs

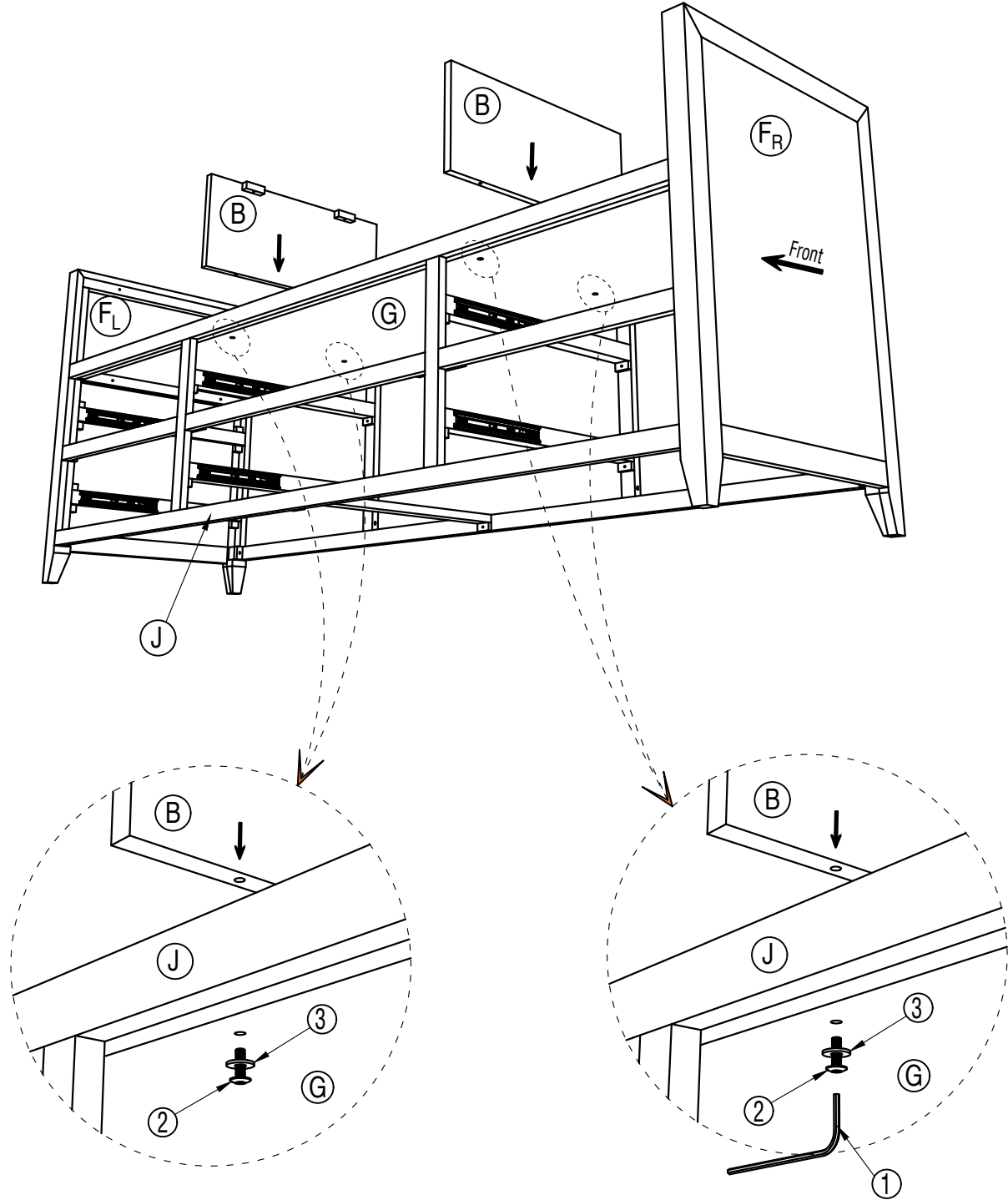

STEP 7

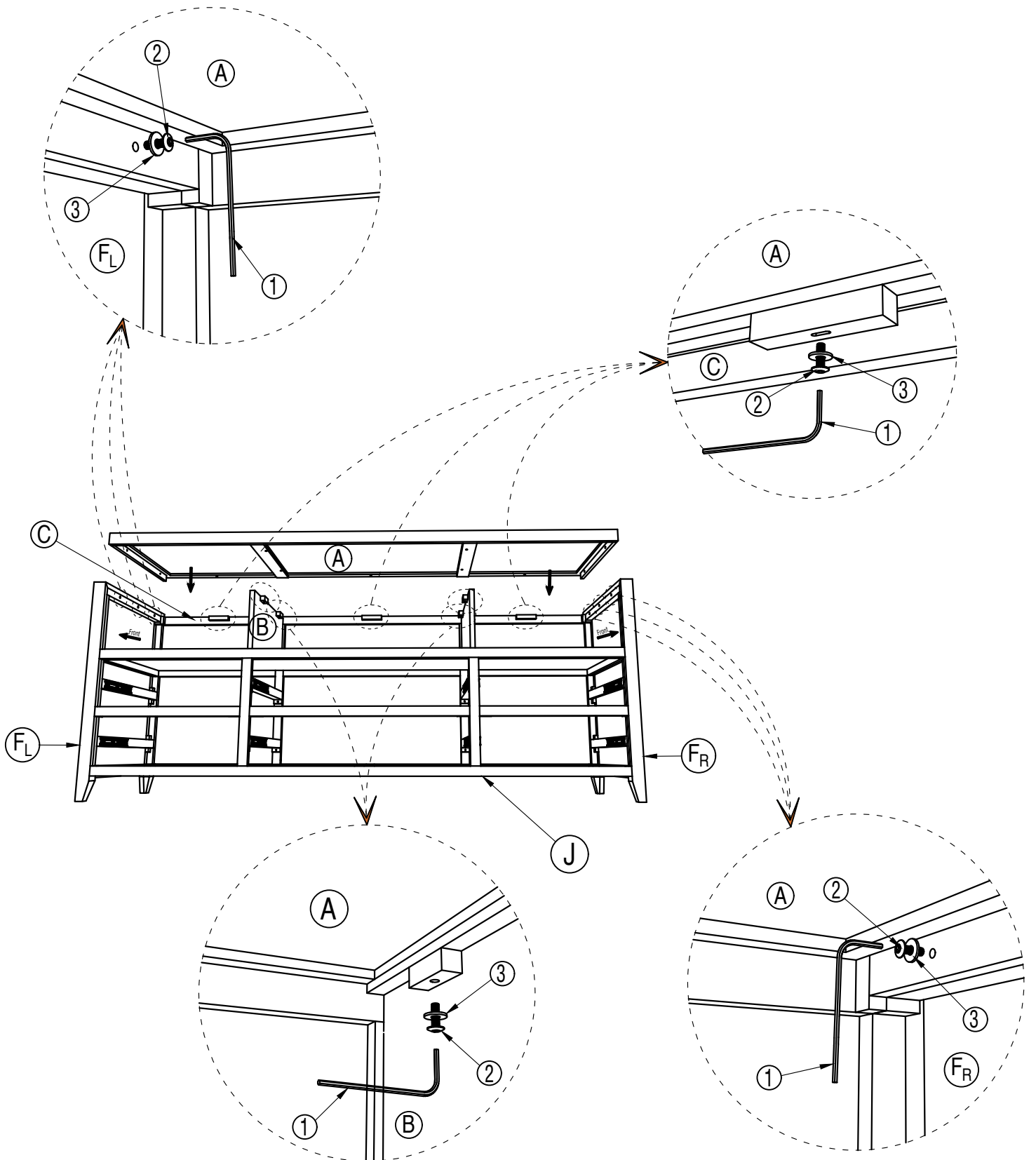

①	②	③
	 6x30mm 4 pcs	 6x16mm 4 pcs

STEP 8



①	②	③
	 6x30mm 13 pcs	 6x16mm 13 pcs

STEP 9

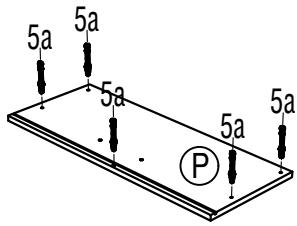

(x4 pcs)

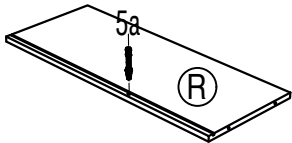

(x4 pcs)

STEP 11

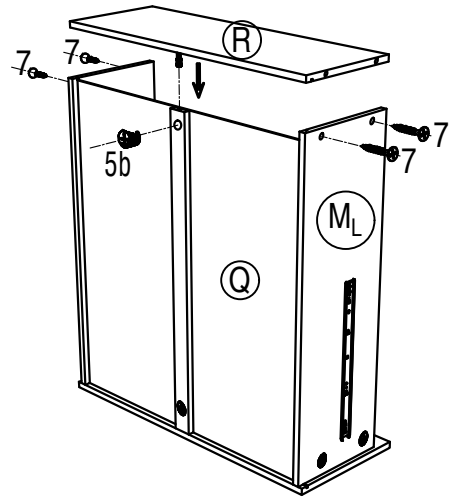

(x4 pcs)

STEP 10

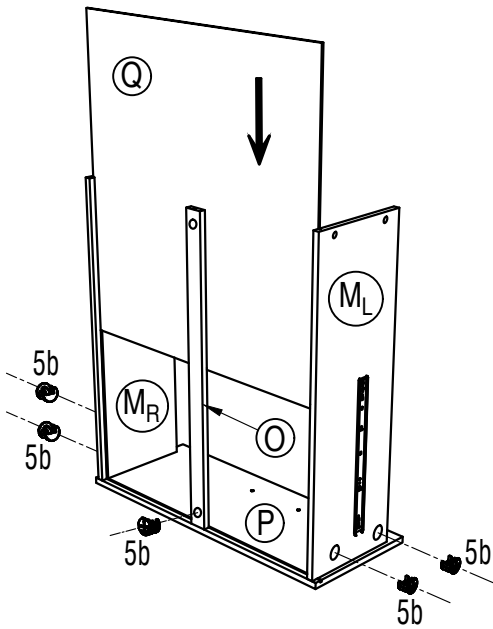

(x4 pcs)

STEP 12

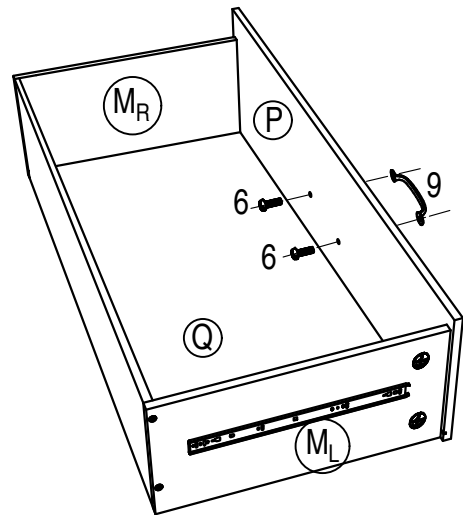

(x4 pcs)

5a



Cam bolt
24 pcs

5a



Cam lock
24 pcs

6



4x20mm
8 pc

7



4x30mm
16 pcs

9

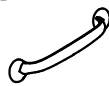

Handle
4 pcs

10

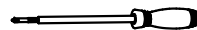

Screwdrivers

STEP 13

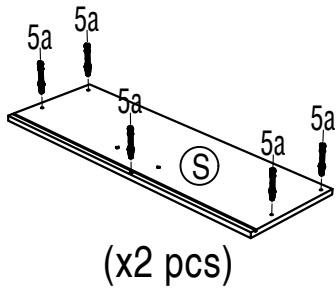

(x2 pcs)

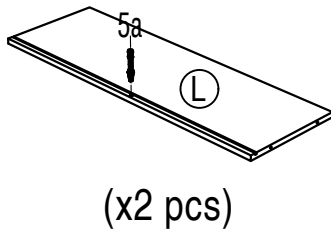

(x2 pcs)

STEP 15

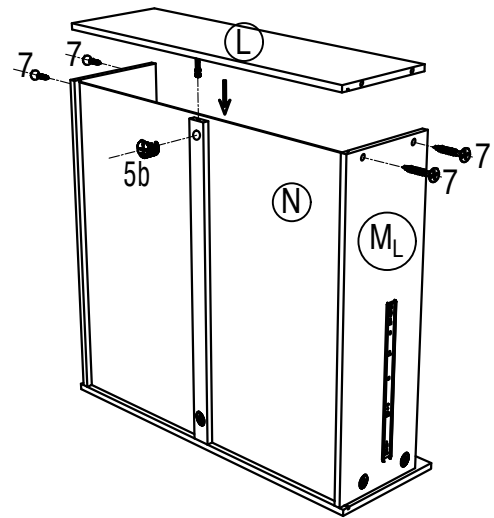

(x2 pcs)

STEP 14

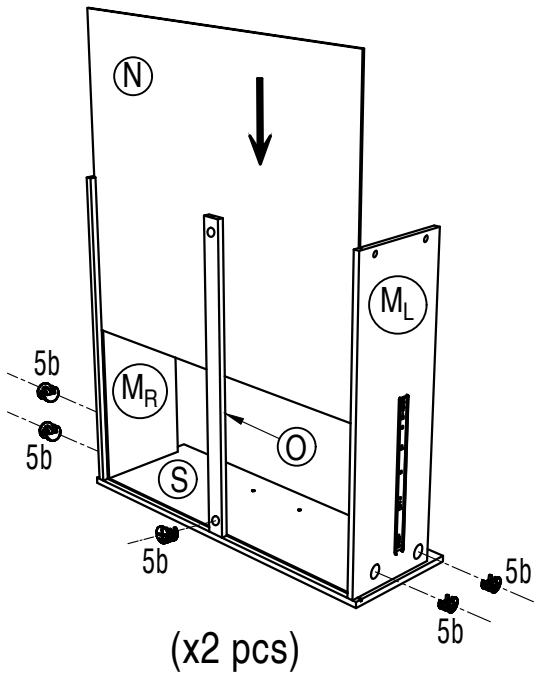

(x2 pcs)

STEP 16

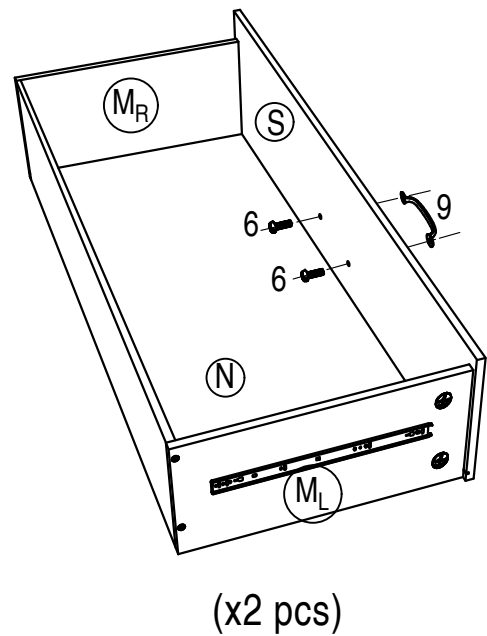

(x2 pcs)

5a



Cam bolt
12 pcs

5a



Cam lock
12 pcs

6



4x20mm
4 pc

7



4x30mm
8 pcs

9

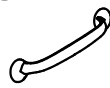

Handle
2 pcs

10

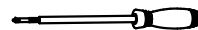

Screwdrivers

STEP 17

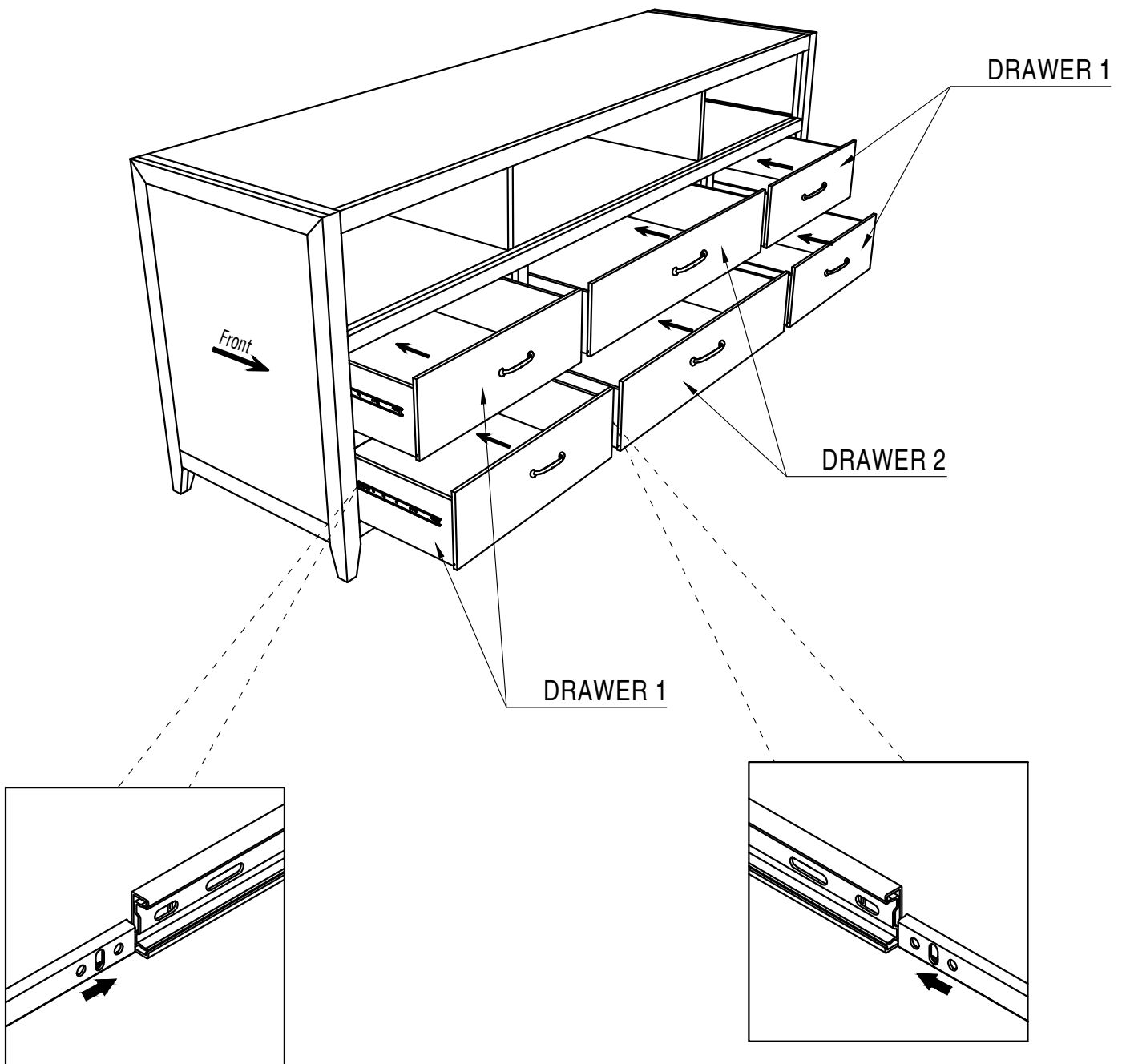

STEP 18

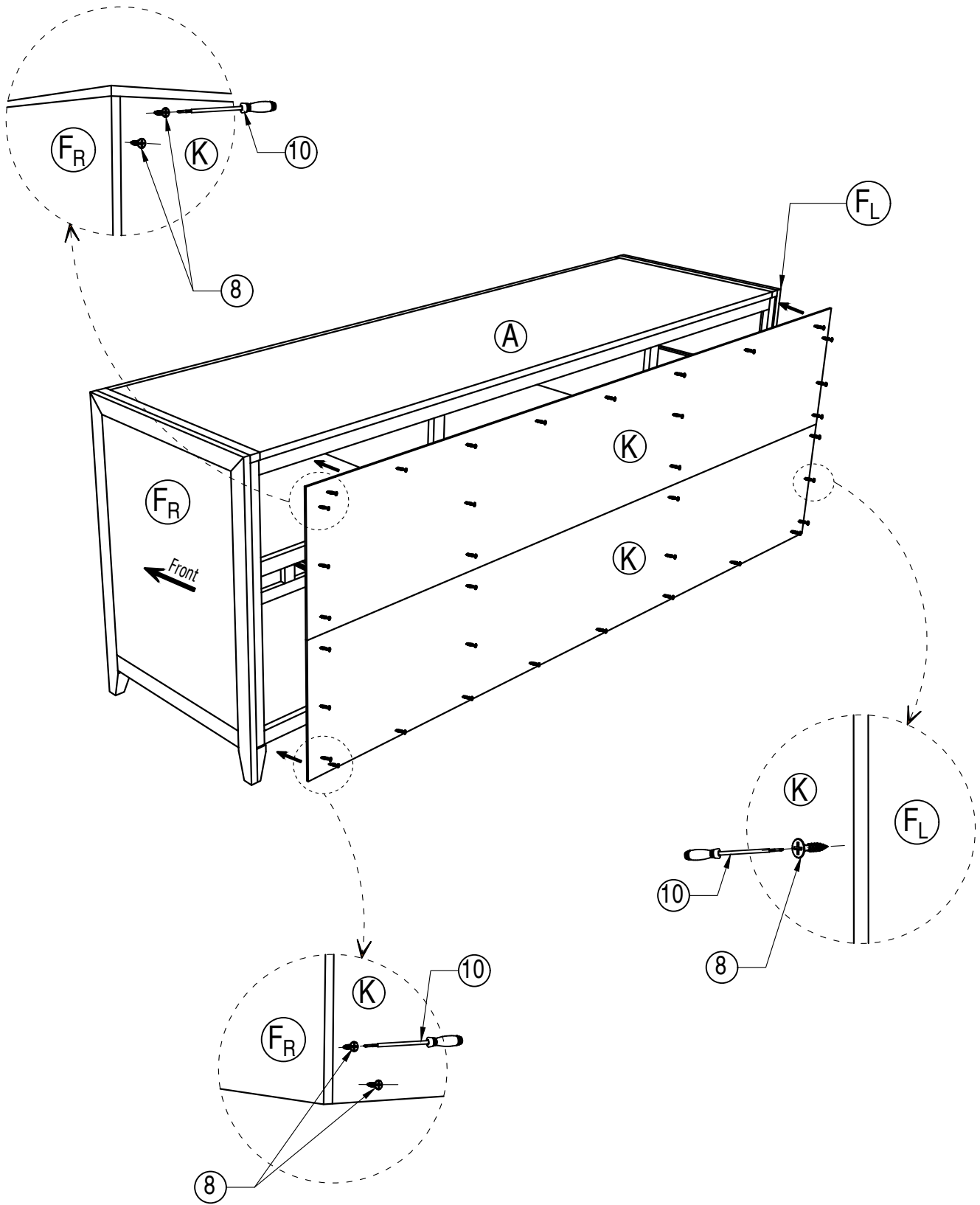

8



3x15mm
36 pcs

10

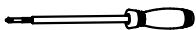

Screwdrivers

STEP 19

