

**Operation Instruction**

**Built-in gas hob**

## **1. Dear customers:**

Thanks a lot for choosing our brand, please read the following instructions carefully before using this appliance. These instructions provide all the information necessary for correctly use of this appliance to avoid damage and danger.

If you have any question in usage, please do not hesitate to contact us. We are ready to do our utmost to give you satisfactory service. Please keep well of this operation instruction.

This appliance must be used in explicit functions, for example cooking. It isn't right to use it in others ways which are dangerous, incorrect or irregular, we will not be responsible for improper usage or damage caused by delivery.

## **2. Operation instruction & suggestion:**

Using this appliance should follow some elementary regulations, ESPECIALLY:

Do not touch the electrical appliance with wet hands or feet.

Do not operate the appliance without wearing shoes

Make sure children should be far away from the appliance and should not use the appliance without anybody watching on.

We will not be responsible for improper usage or damage caused by delivery.

## **3.Note for your safety:**

Before installation, please make sure the appliance is fine, in case of any problems, do not use it then contact the producer or technician.

Make sure children should be far away from the packing materials. Such as plastics sack, foam, nail and packing belt.

For all of them may cause serious danger or damage.

It is dangerous to alter the specifications or modify the product in any way.

Do not clean or maintain the appliance without power off.

When not use it or change it, before you do that, make sure it can't work, especially make sure children should be far away from it.

After usage, turn the switch knob to "off" position, make sure the flame is completely out, shut off the general gas valve.

This appliance is designed to be operated by adults, children should not be allowed to use it or play with this appliance.

During operating the appliance, the outer surface will be hot. Take care not to touch these surfaces during using.

During usage make sure children should be far away from the appliance.

## 10. Electrical part

### (1) Detail instruction

The manufacturer recommends that all units with electrical components be installed by a qualified electrician or serviceman to make certain that.

The electrical outlet supplies volts and of proper ampere rating.

The unit is firmly grounded as shown below. The power wire should not be touched to hot surface and the temperature around the wire should be less than 75 degrees.

After installation, power switch or plug should be at proper place.

### (2) The manufacturer

recommends that all units with electrical components be installed by a qualified electrician or serviceman.

The electrician or serviceman should make certain that the electrical outlet supplies of proper ampere rating.

## 11. Technical Data

Gas type	LPG	Natural gas	Unnatural gas	
Fixed pressure(Pa)	2800	2000	1000	
Inner diameter(mm)	□9.5			
Fixed heat flux(kw)	□120:3.3	□90:3	□65:1.75	□45:1.0

## 12. Packing List

gas stove	1
instruction booklet	1
plastic bag	1
hole board	1
foam	1

## 13. After-sale Service

Warranty period is half a year for the whole utensil(from the day you purchased, judging on the date showed in the purchsing invoice).Please contact our maintenance centre when you need necessary consultation or repair the appliance.In case of the expiry of warranty period, we will only charge you for the necessary costs.(We will not be responsible for improper usage or damage caused by delivery.)

Notes : due to technology improvement, the gas hob available in your hand may be a little different from the picture showed in the booklet.

Please forgive us for not informing you again.

## 14. Warranty Card

Customer name	Address		
Purchasing date	Purchasing shop	Model number	
Invoice date	Customer telephone number	Post code	
Date			Repair personnel
Please keep this card and Purchasing Invoice for after-sale service			

9

## 4. Bulit-in structure design feature:

### (1)Gas Burner:

1. left-front burner□65mm(90mm)
2. left burner□120mm
3. left-back burner□120mm
4. right-front burner□65mm
5. right-back burner□45mm
6. right burner□120mm
7. Middle burner□120mm(90mm)

### (2)Control panel:

8. left-front switch
9. left switch
- 10.left-back switch
- 11.right-front switch
- 12.right-back switch
- 13.right switch
- 14.middle switch

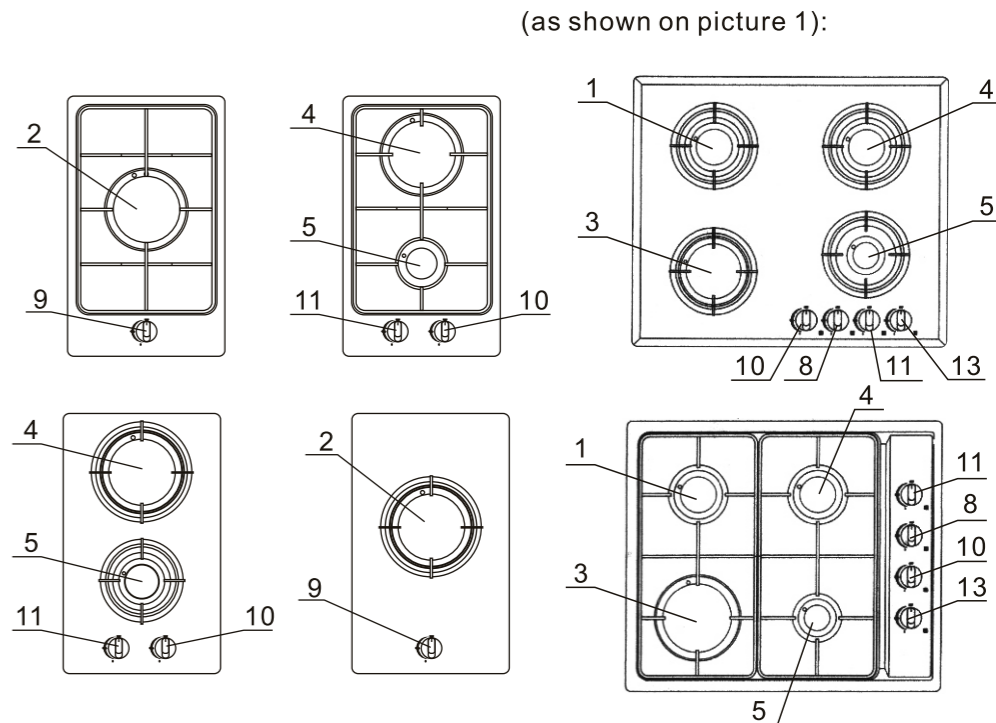

2

Picture 1

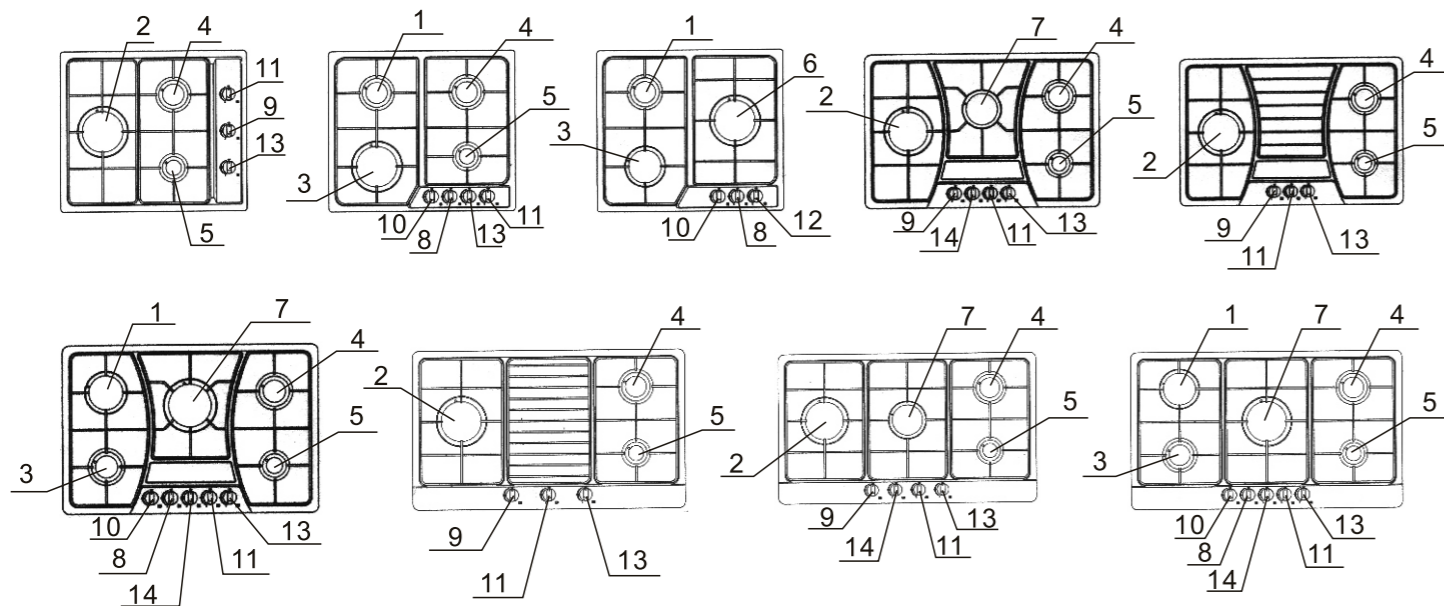

### IMPORTANT:

Make sure that the place you select provides easy access to electricity or gas for the unit to operate and should provide adequate ventilation. If use the appliance for a long time, open the window or install a ventilating hood at the same time add the function.

## 8. Installation

### (1) Remarks:

In order to install built-in gas hob, you should first put the template on the cooktop, then put the appliance in after.

#### REMEMBER:

The free space under the appliance and over it should not be less than 30mm.

From wall to the appliance, the distance should not be less than 35mm

If a ventilating hood is provided, distance from the working top to the bottom of the hood should not be less than 650mm.

For not built-in structure design there should be a heat insulation device between the appliance's bottom and other units.

For built-in structure design the distance between the appliance and the oven should not be less than 30mm, both should be connected to gas individually.

## 9. Gas part

### (1) Usually use 3 types of gas

LPG

Unnatural gas

Natural gas

### (2) Installation

Before installation, make sure gas type used must be in accordance with the required gas type, mixing with other gas type is forbidden.

### (3) Important

Please check to make sure all connections are tight, check for leakage in your tank or the connecting hose by using soap and water around the connections.

If rubber hose is used, it should be of minimum practical length so as to avoid bending. Periodic inspection is recommended for added safety.

### (4) Replace the nozzle

Take off the burner cap and the aluminium cap, then use suitable instrument for replacing the nozzle (as show on the picture)

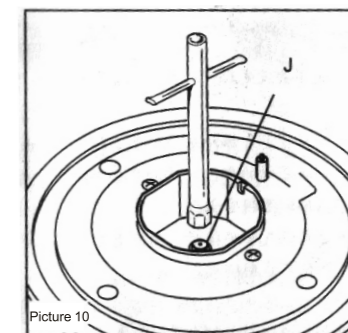

### Choose proper place:

Make sure air can go into the room easily so that the flame is on the best condition.

Pay attention to ventilation, making wind-in opening more than one and the square should not be less than 100cms  
The model without safety device=s square of vent should be at least 200cms

The wind-in opening should be near the floor, it would be better face to vent window.

The air will come from other room (but not bedroom or any dangerous places), in this case, keep the door open.

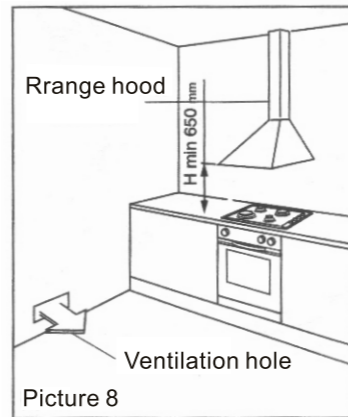

### Burning resultant discharge:

Vent cover should be connected to outdoors (as shown on picture 6)

You may also use blower the efficiency should reach to 3-5 times than kitchen air current quantity(as shown on picture 7)  
As above refer, if only the room with proper vent can it be installed blower.

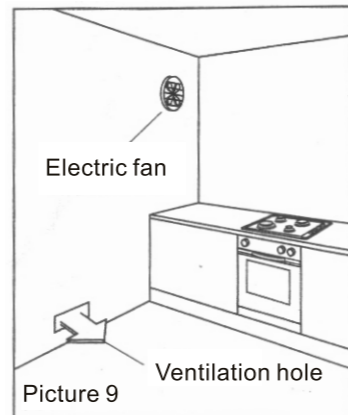

## 5.Operation Instruction.

### A. Gas Burner:

The gas is adjusted by the switch(as shown on picture 2). Press the switch fully and revolve to the opposite direction of clock until it reached the position as followed:

- Sign OFF □ gas valve is shut off
- Sign □ largest flame
- Sign □ smallest flame

The position of largest flame liquid material will boil very soon. When the switch in the largest flame position, turn the thermostat knob to a desired temperature suitable for every slow cooking and warming up of food.

Press the switch fully and revolve to the opposite direction of clock until it reached the position of OFF

Move the switch position from the burner will burn with medium flame.

### B. Ignition :

Three steps are as follow:

- (1).Press the switch gently(as shown on picture 3) and revolve to the opposition direction of clock until it reached the position of largest flame. Press the switch then it will ignite.
- (2).You should press the switch for 5 to 10 seconds for safety device models.
- (3).Adjust the general gas valve to the flame you need.

If the flame is out for certain reasons, the safety device will cut off the gas power automatically. Turn the switch to OFF

position, then ignite again, you should wait for 1 minute when you do that; Due to the air in the tong, there may be unsmooth ignition ,revolve the switch to OFF position and ignite again.

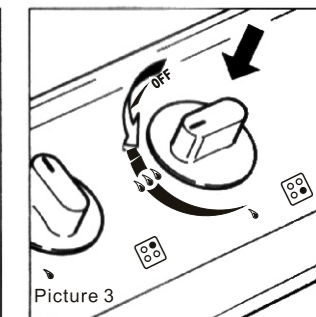
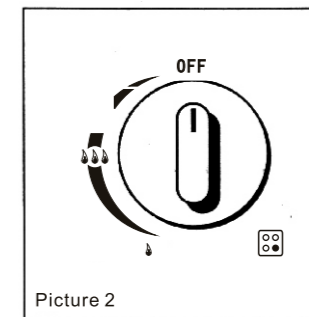

### C. Choices of burners

On the control panel, each knob has a sign marked control which burner. To use which burner should be according to the right pan size and efficiency.

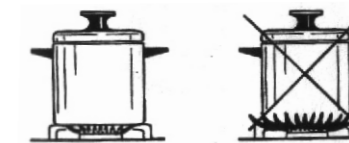

It is very important for good heating conduction that good utensil with flat bottom be used. Evenness of the pans bottom can be checked by a ruler or straight edge of the table. Use the right pan size to avoid waste of energy.

## 6. Cleaning & Maintenance

### (1) Suggestion:

Clean the appliance after the unit had cooled off, especially for the porcelain enameled part.

Do not leave alkaline with acid radical or chlorine radical Important

Be sure to pull out the electric cord from its service outlet

### (2) Porcelain enameled part

Use sponge or cloth soaked in soap and warm water

Avoid using cleaning powders or harsh abrasive which may cause scratching of the surface

### (3) Burner & trivet part

Clean the removable part using sponge or cloth soaked in soap, like burner and flame ring should be dried and put correctly

### (4) Stainless steel part

Use the soft rag or sponge to clean

Important:

Due to the temperature too high, the color around the burner will change by used too often

### (5) Trigger electrode □ safety valve sensor

Check electrode S (picture 6) always keep it clean bestow the burner correctly (only for the appliance with safety valve).

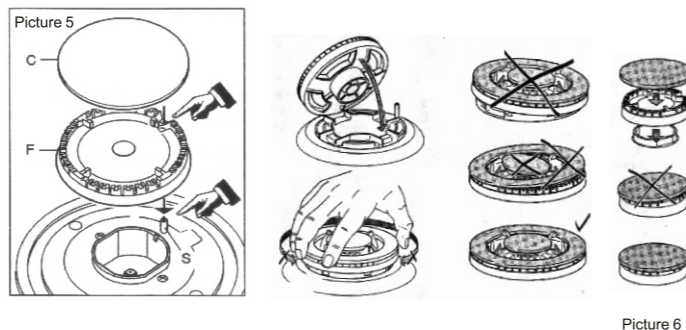

### (6) Put the burner cap correctly:

Install the flame lid ring correctly and carefully as picture arrowhead shown. The burner would not move if installed correctly.

Incorrectly installation will cause inequality flame and cause mangle at the same time.

5

## 7. Installation Suggestion:

### Important tips:

The manufacturer recommends that all units should be installed by a qualified person or serviceman to make certain that.

The installation of the appliance must follow the instruction provided by producers.

We suggest you choose cupboard or cooktop can resist temperature more than 75 degrees.

Make sure that the unit is well leveled in relation to the ground. Improper leveling can affect the function of the appliance.

Easy burning or easy explosion goods cannot be put near the appliance (for example, window curtain)

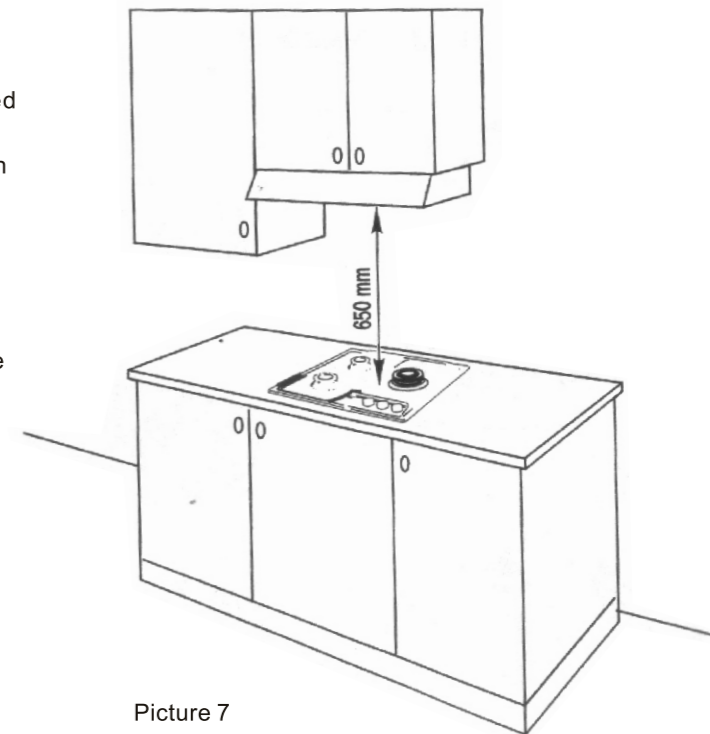

6