

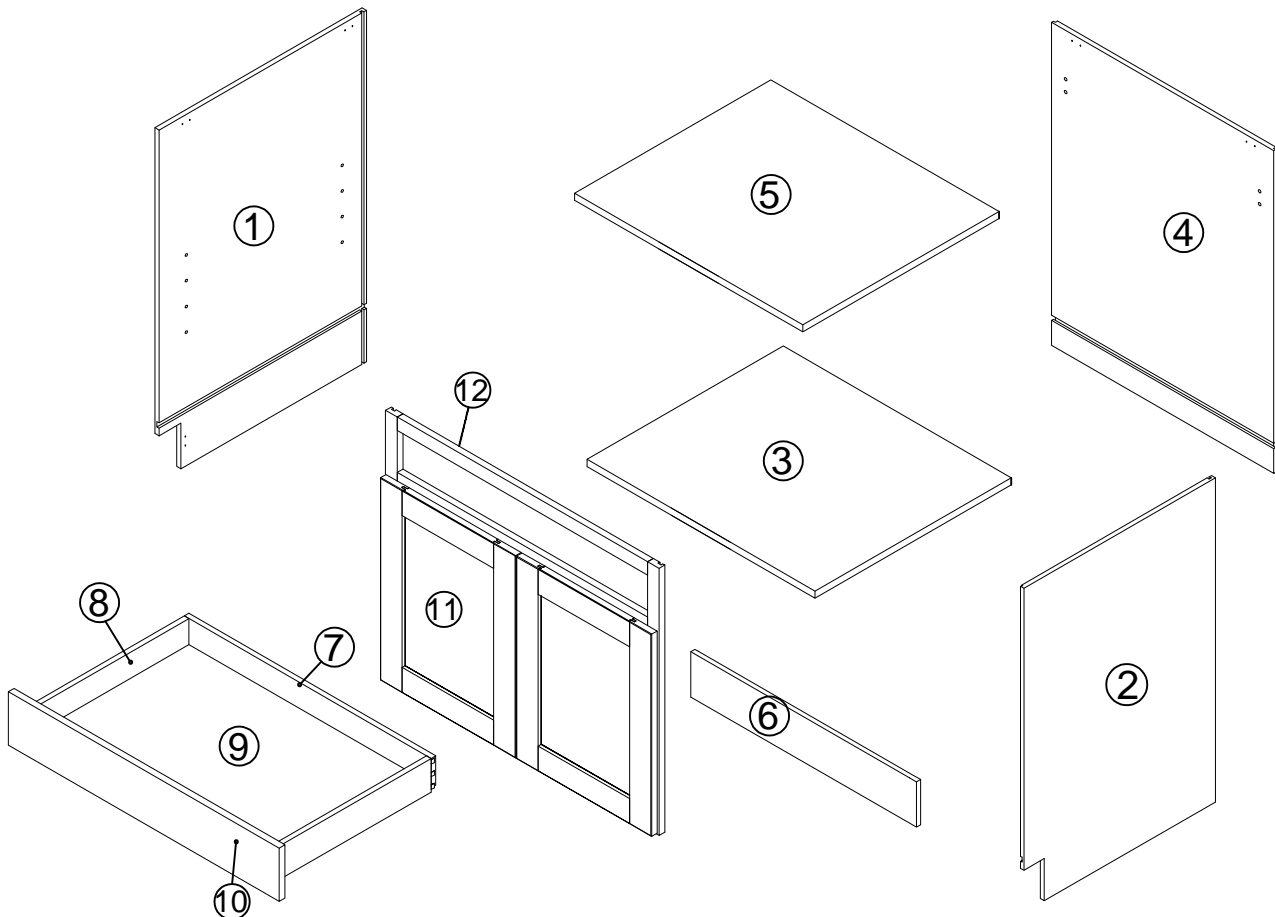

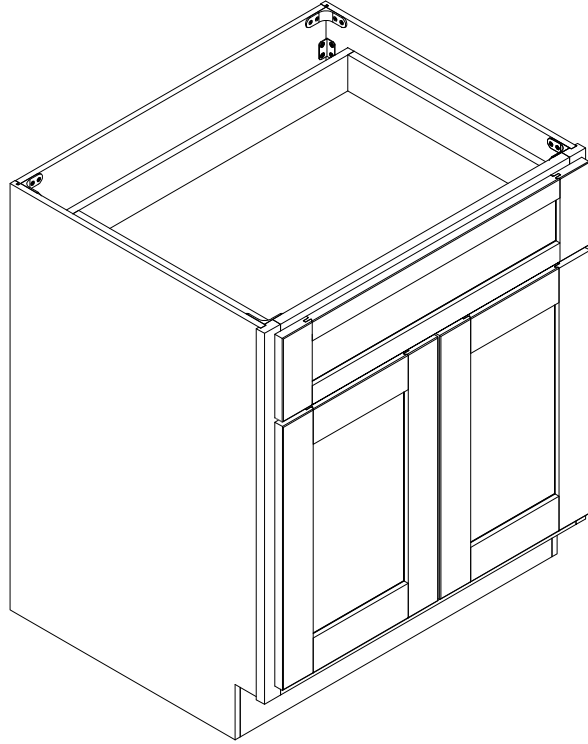



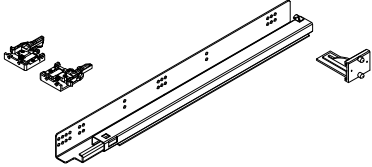
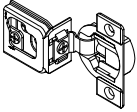
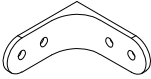

PROJECT NAME:  
 ITEM NAME: BASE CABINET\_2DOOR\_1DRAWER  
 ITEM CODE: B24, B27, B30, B33 , B36

PARST LIST

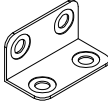
NO	NAME	QTY
1	LEFT SIDE PANEL	01pcs
2	RIGHT SIDE PANEL	01pcs
3	BOTTOM PANEL	01pcs
4	BACK PANEL	01pcs
5	SHELF	01pcs
6	TOE KICK	01pcs
7	DRAWER BACK PANEL	01pcs
8	DRAWER SIDE PANEL	02pcs
9	DRAWER BOTTOM PANEL	01pcs
10	DRAWER FACE&DRAWER FRONT PANEL	01pcs
11	DOOR	02pcs
12	FACE FRAME	01pcs





HARDWARE LIST

NO	NAME	picture	QTY
A	GLIDES		01pcs
B	HINGE 1-1/4		04pcs
C	90° METAL BRACKET		04pcs
D	SHELF PINS		04pcs
E	CORNER BRACKET		11pcs
F	Φ3.5×12mm SCREWS		61pcs
G	Φ4×25mm BACKBOARD SCREWS		3pcs
H	Φ4×19mm HINGE SCREWS		4pcs
k	Φ3.5×14mm HINGE SCREWS		8pcs
I	BUMPER		8pcs

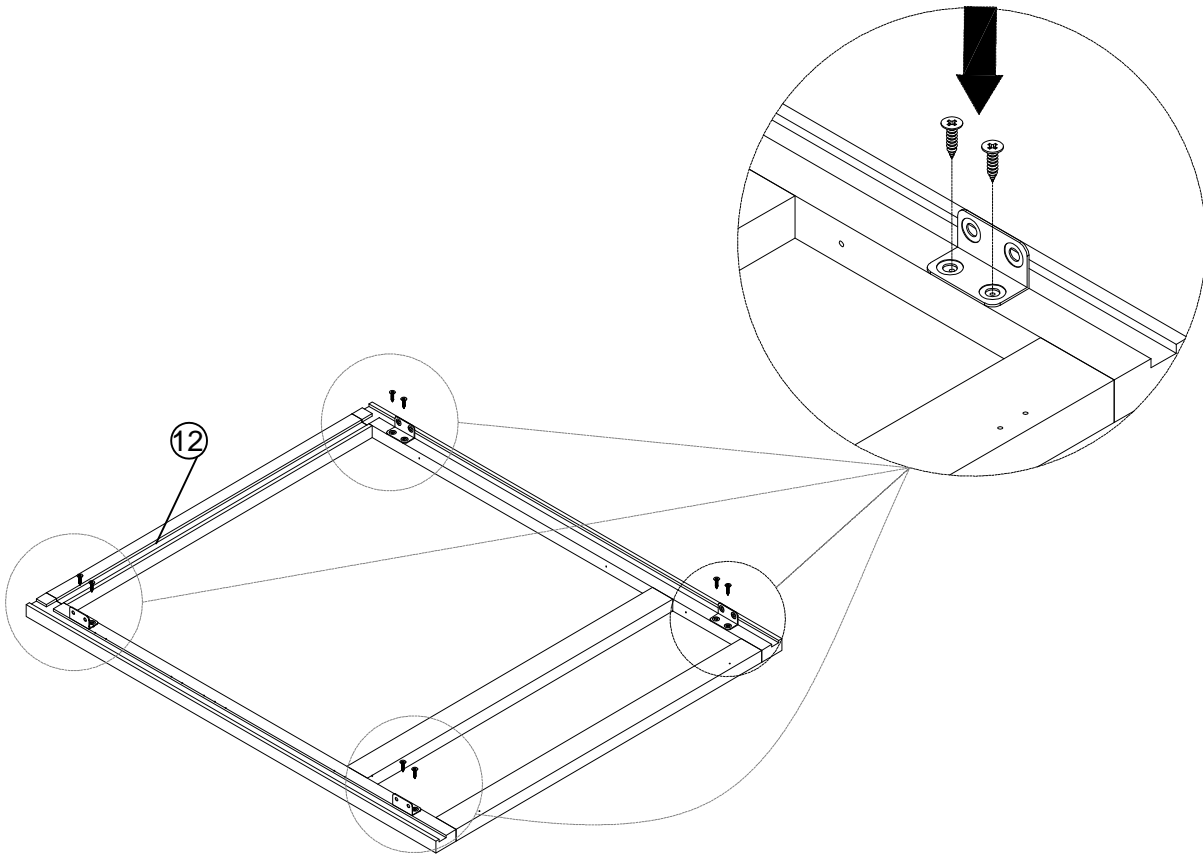
<b>STEP1</b>	<b>E x 4</b>	<b>F x 8</b>
		



<b>STEP2</b>	<b>E x 6</b>	<b>F x 12</b>
		

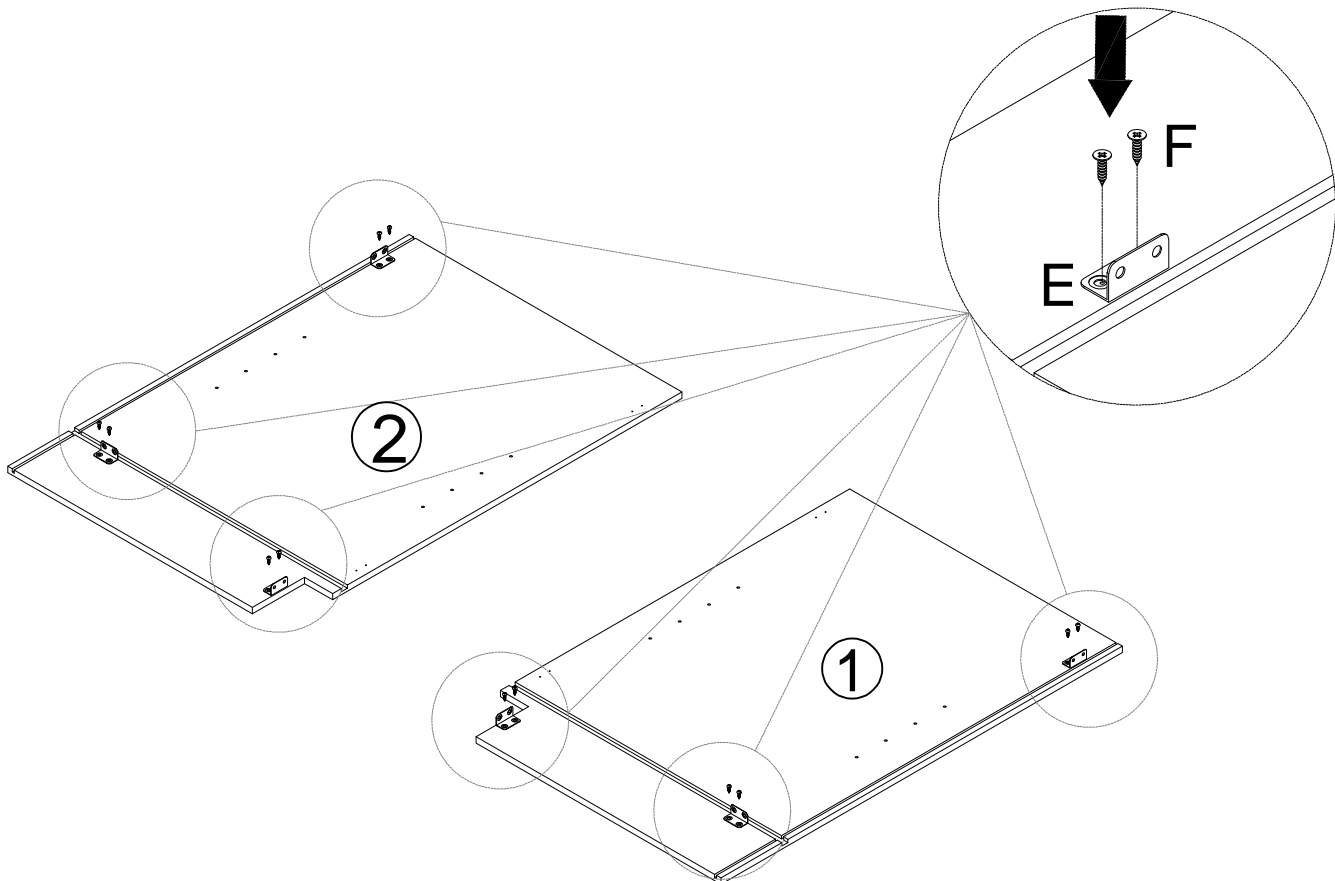

STEP3

F x 8

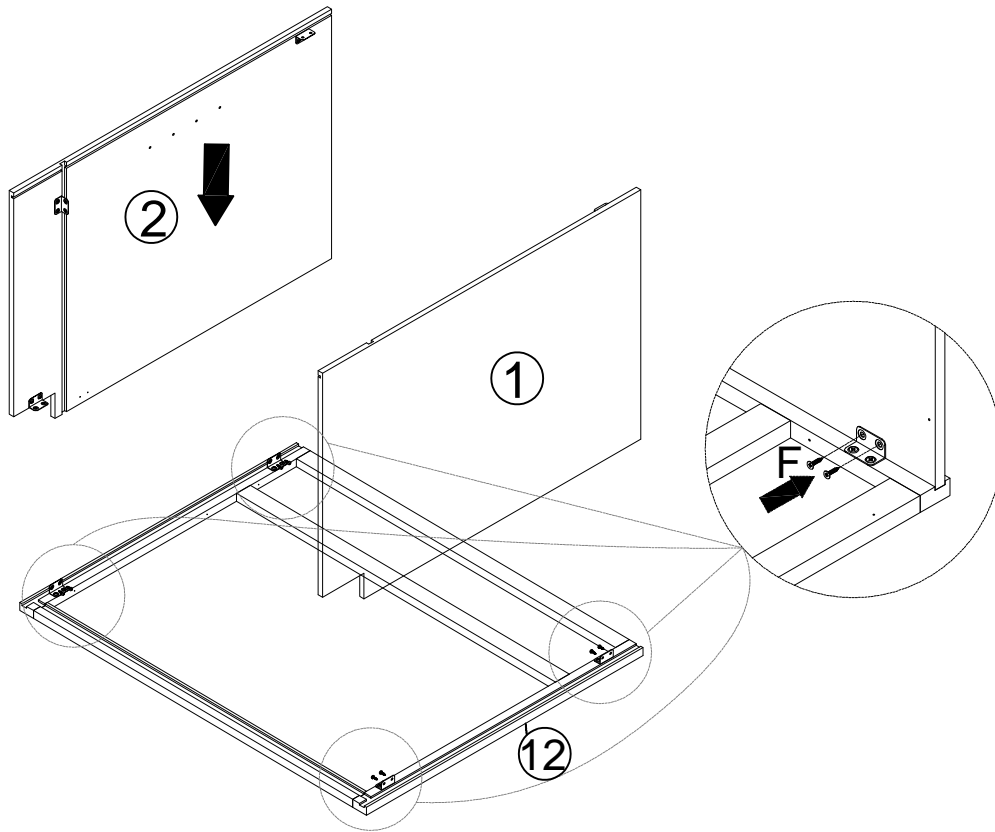

STEP4

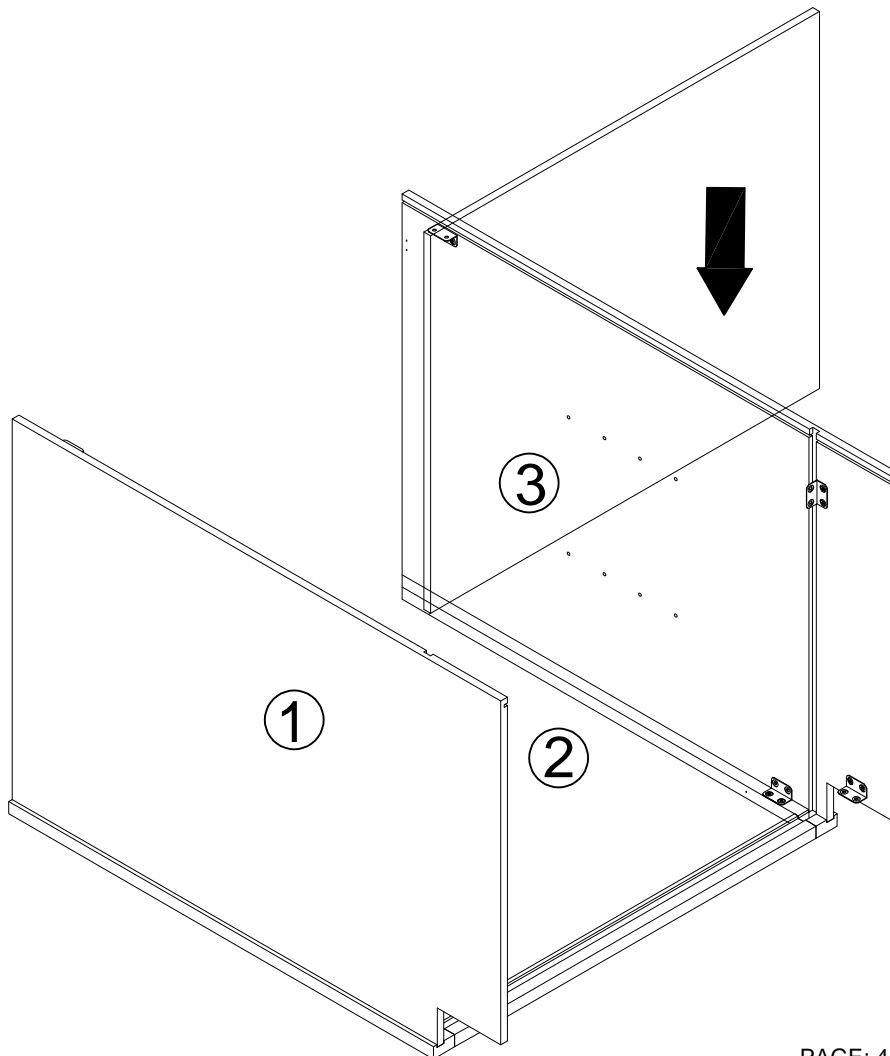

STEP5

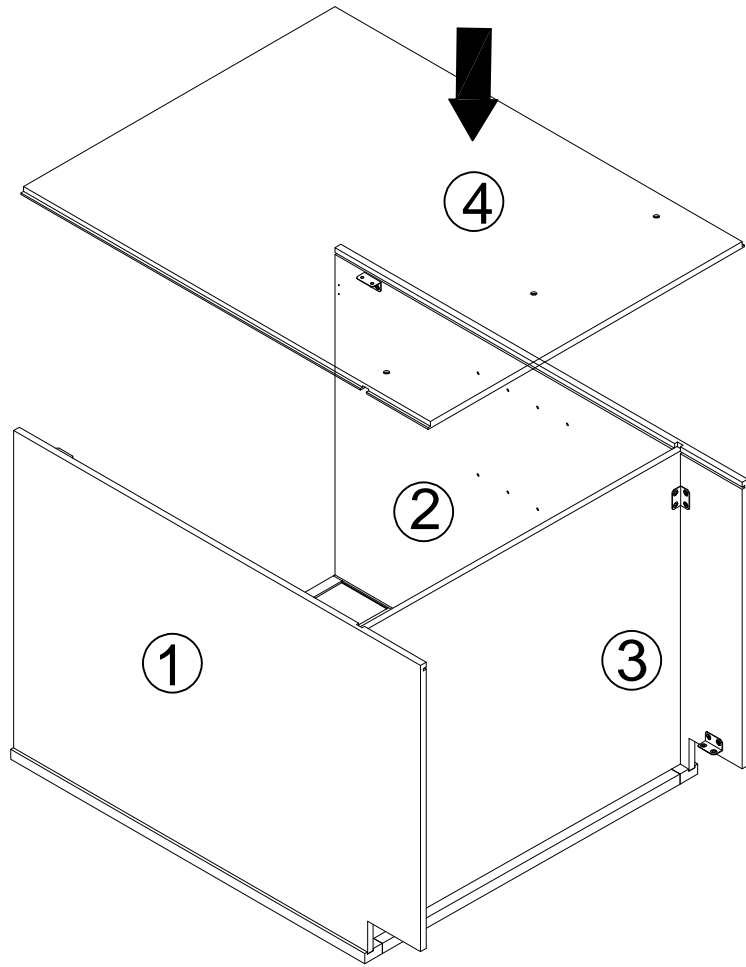

STEP6

F x 8

G x 3



30" and above  
have 3 pcs G

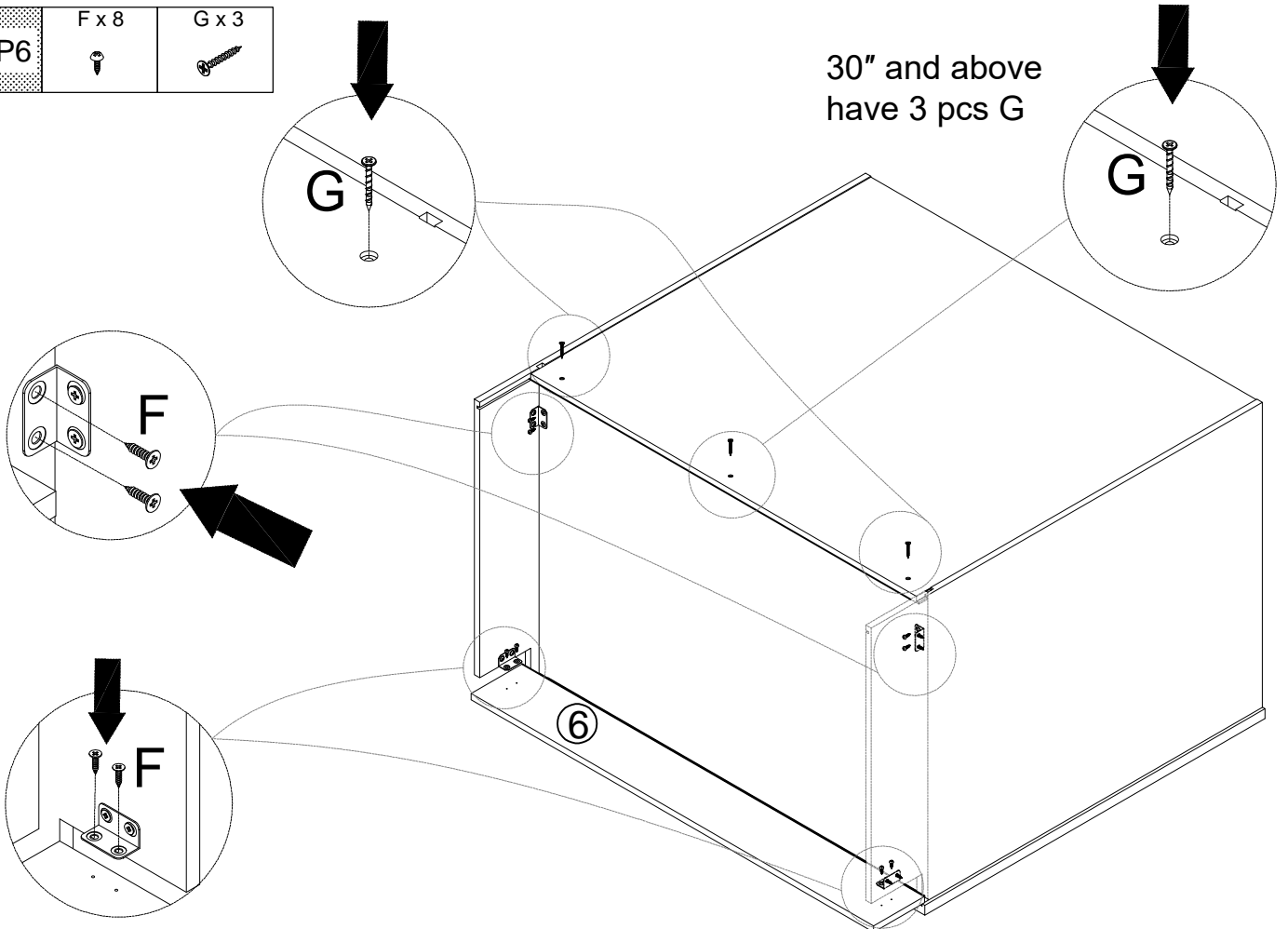

**STEP7**

F x 4

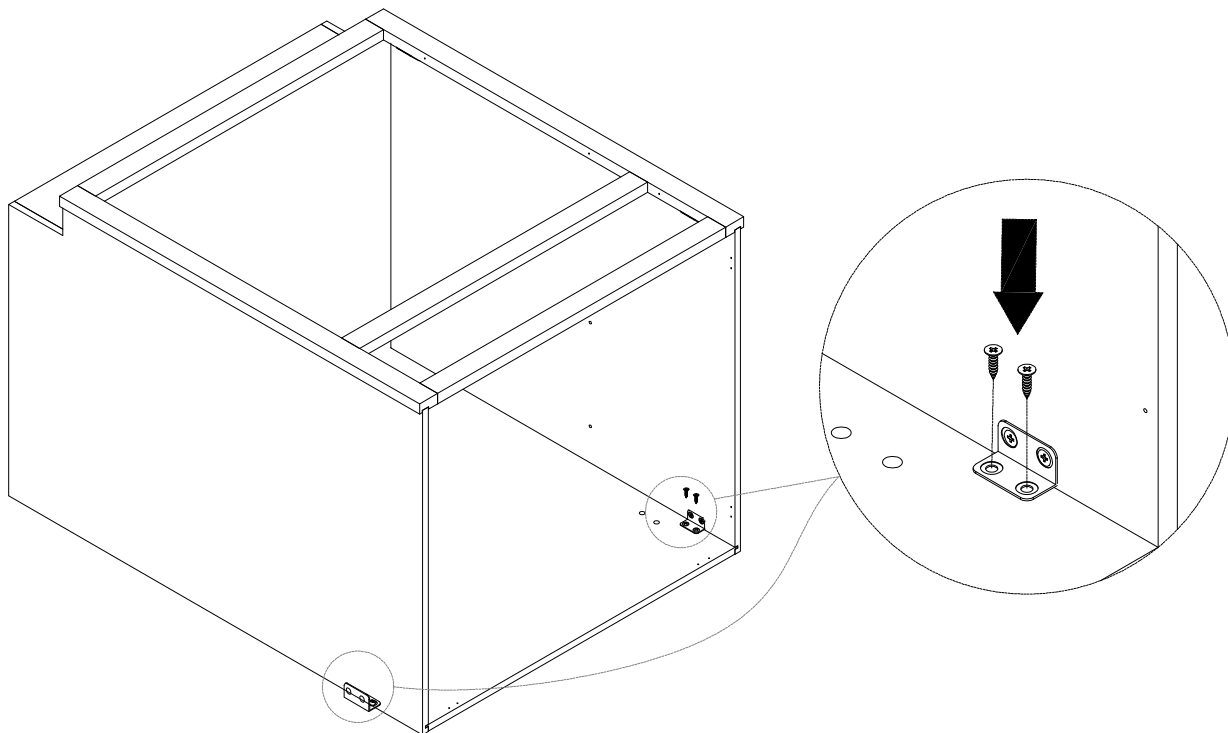

**STEP8**

C x 4



F x 16

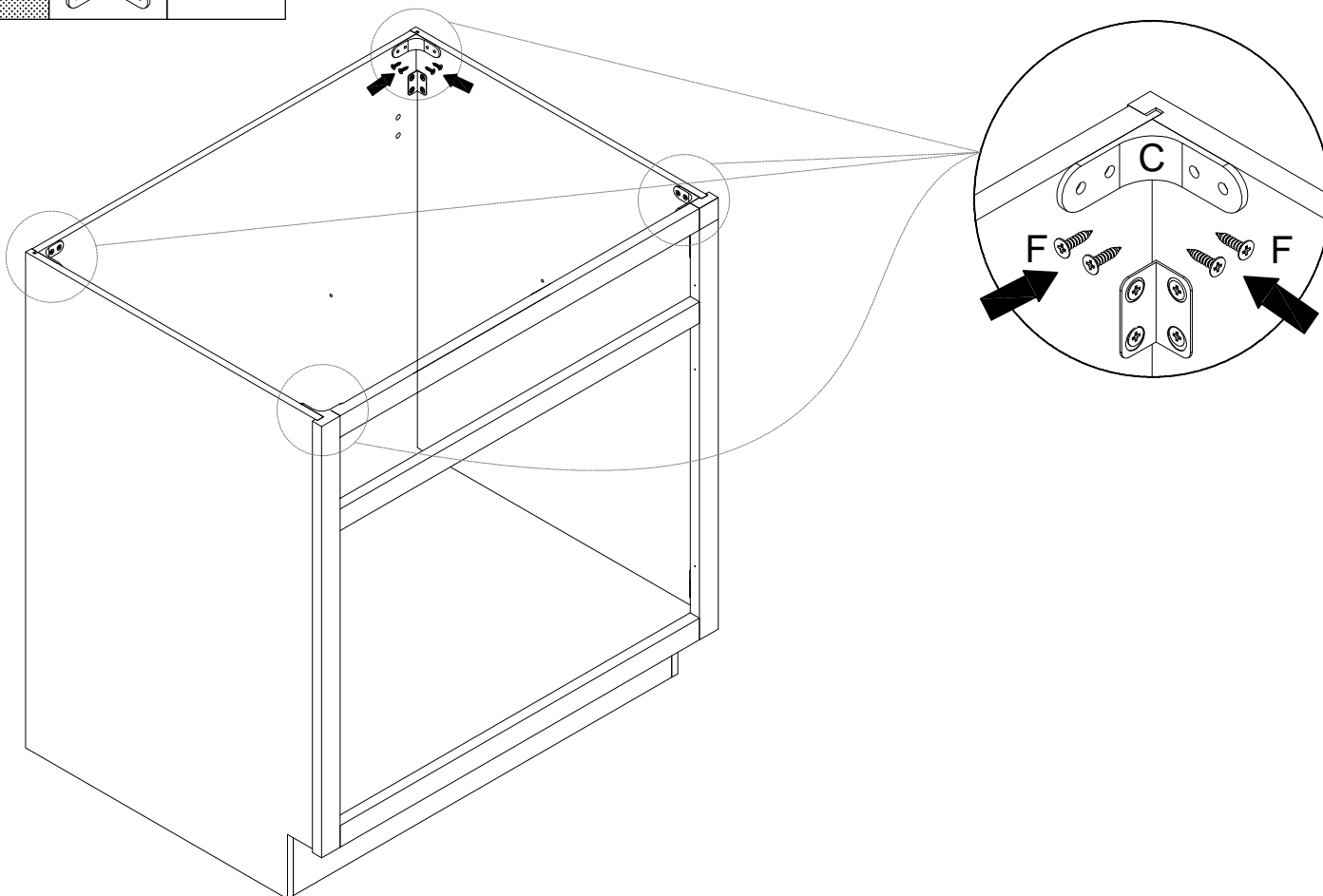

**STEP9**

B x 4



K x 8

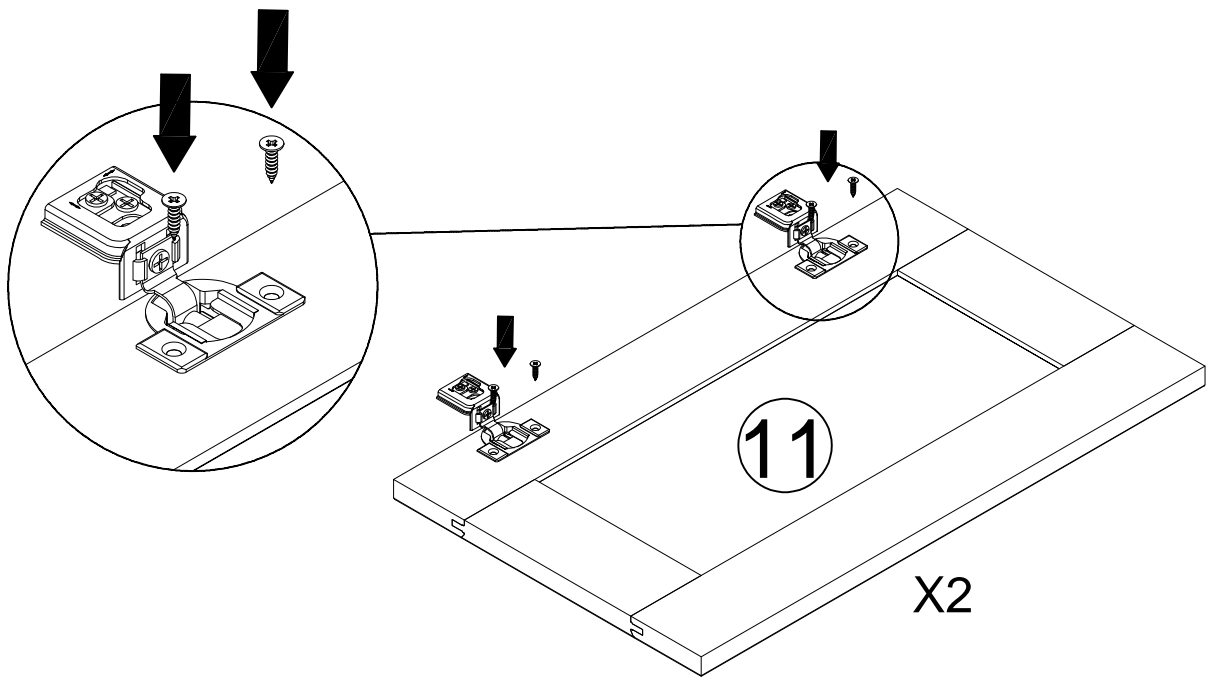

**STEP10**

H x 4

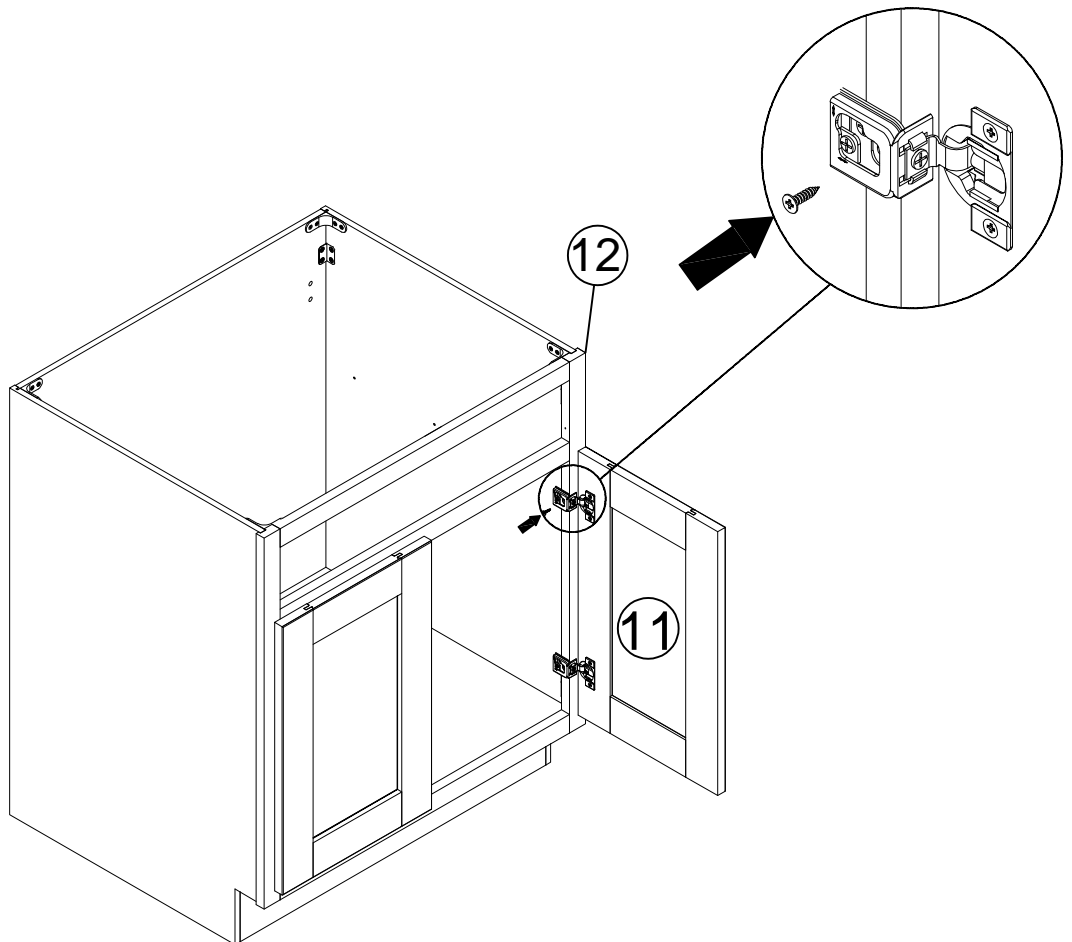

STEP11

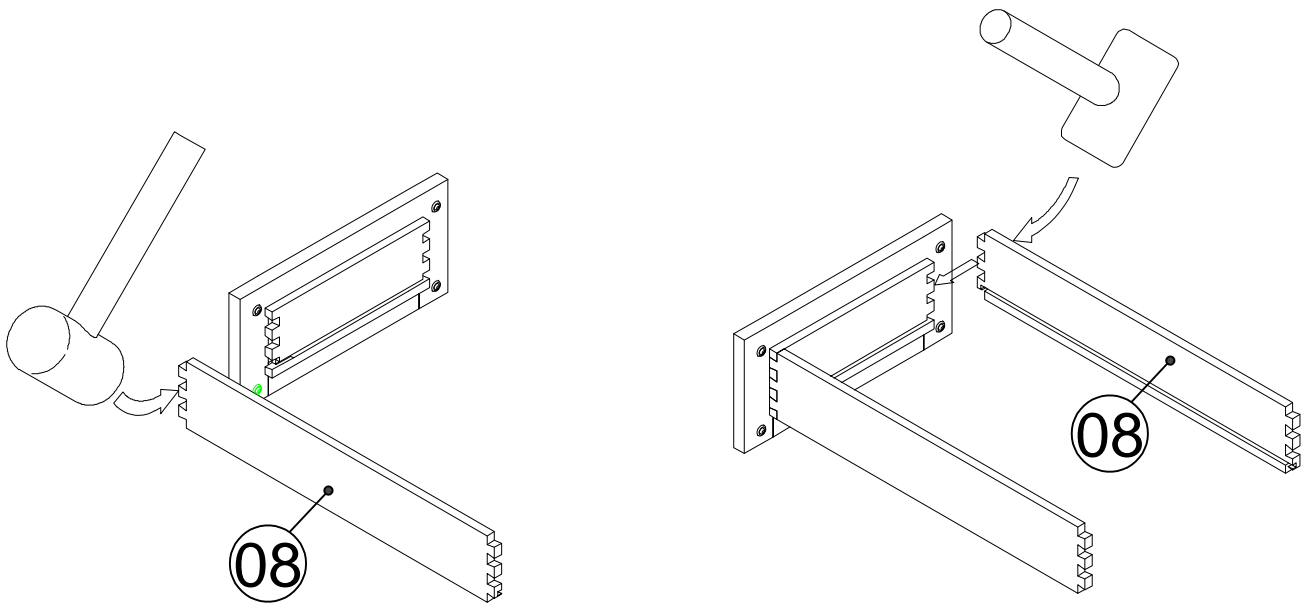

STEP12

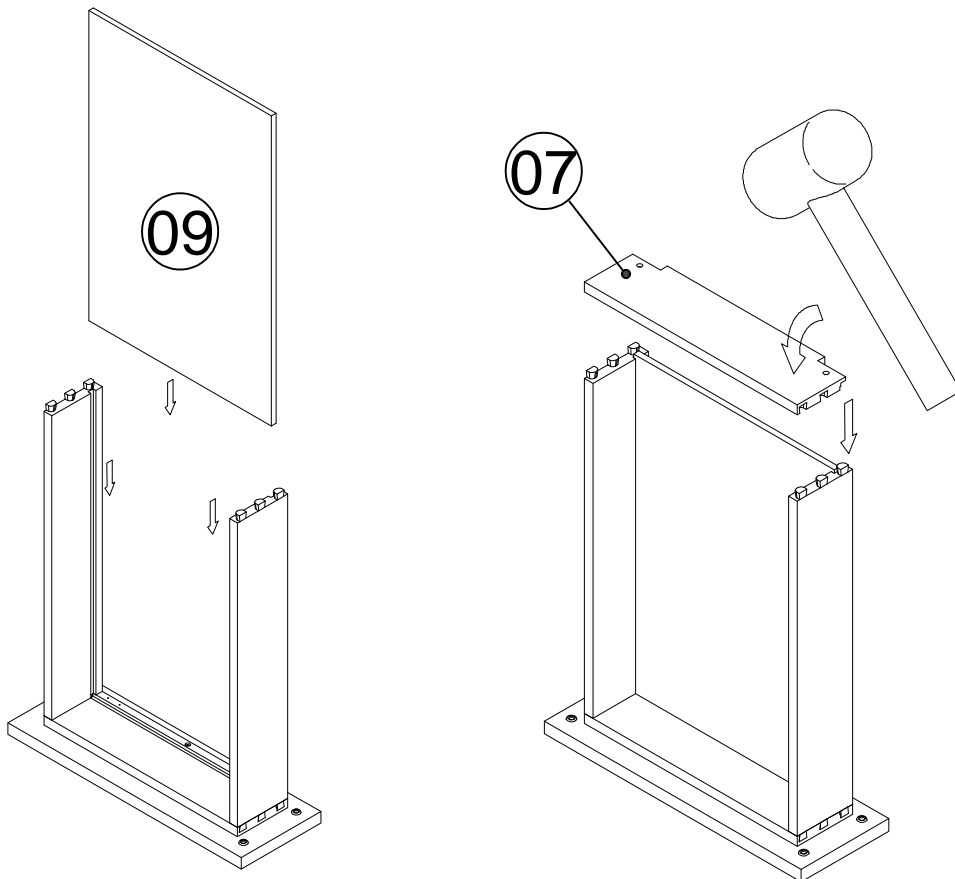

**STEP13**

A x 2

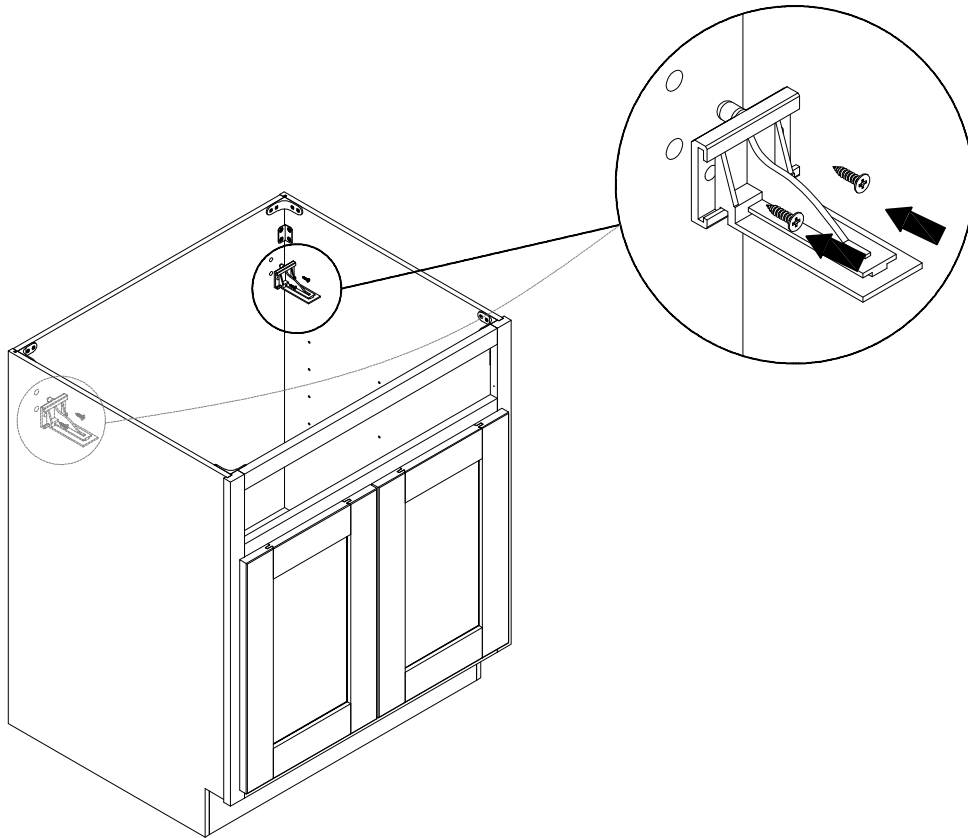

**STEP14**

A x 2

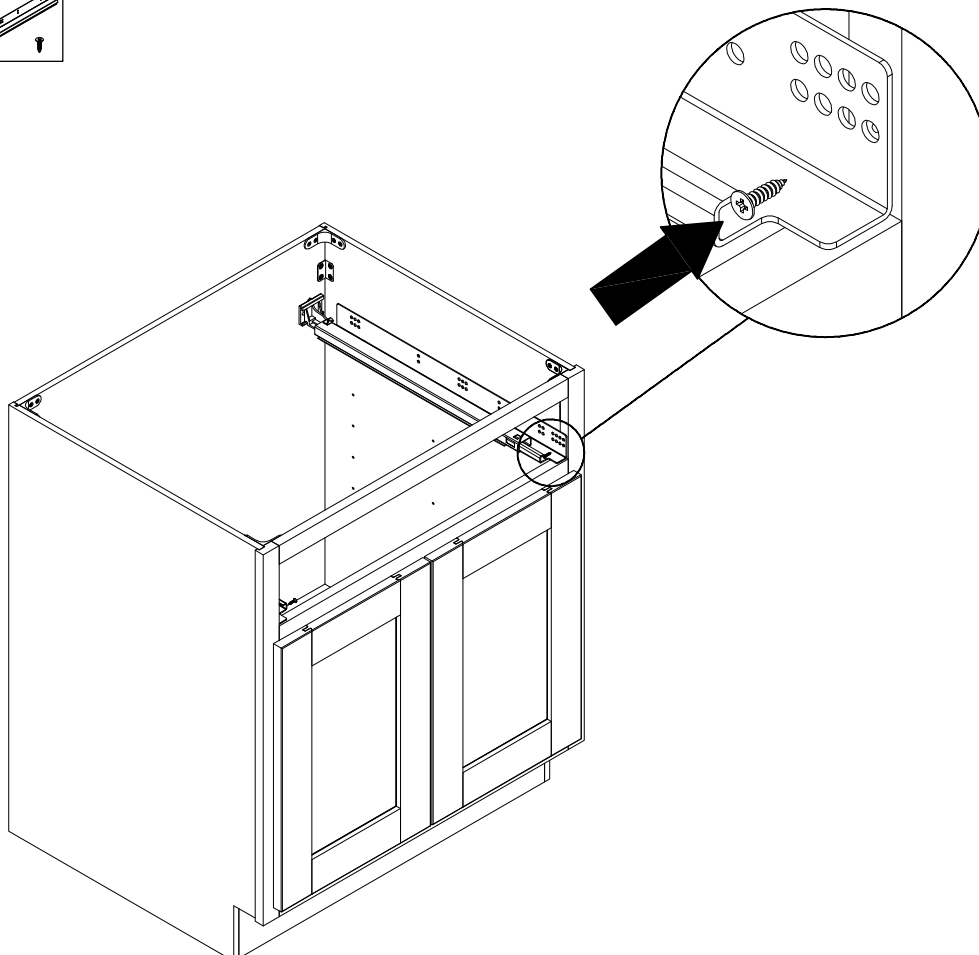
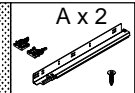

STEP15

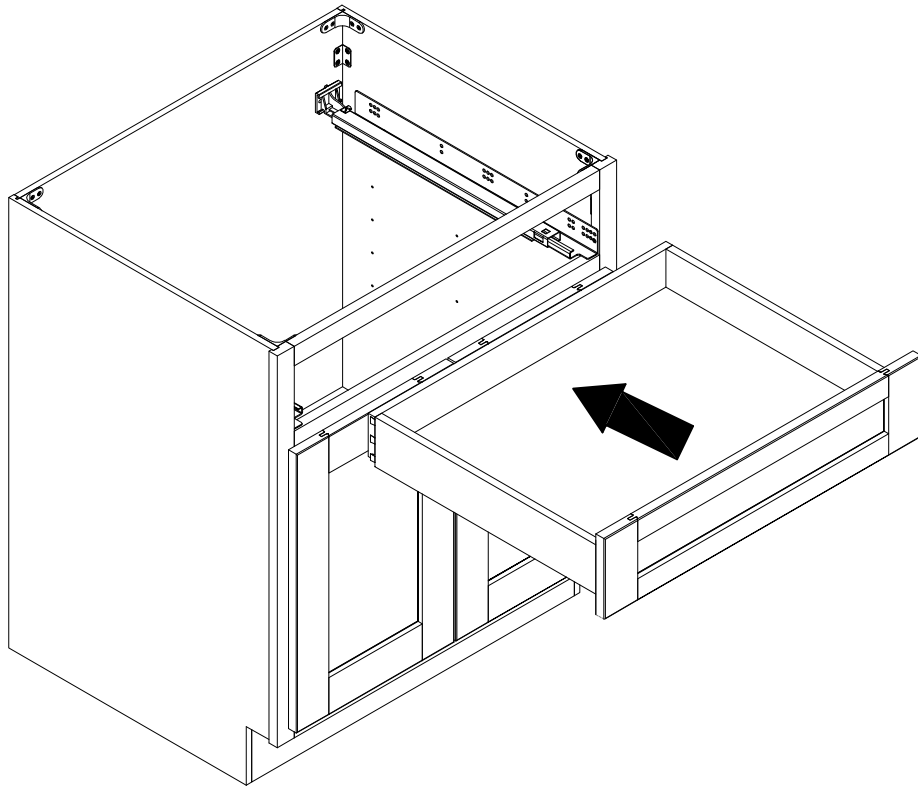

STEP16

D x 4

