

BEFORE YOU START PLEASE READ INSTRUCTIONS CAREFULLY

- Check the pack and make sure you have all the parts listed.
- When you are ready to start, make sure you have the right tools at hand (**not supplied**) including a Phillips screwdriver, Stanley knife, wood saw, step ladder and drill with 2mm bit.
- Ensure there is plenty of space and a clean dry area for assembly.

TIMBER

As with all natural materials, timber can be affected during various weather conditions. For the duration of heavy or extended periods of rain, swelling of the wood panels may occur. Warping of the wood may also occur during excessive dry spells due to an interior moisture loss. Unfortunately, these processes cannot be avoided but can be helped. It is suggested that the outdoor building is sprayed with water during extended periods of warm sunshine and sheltered as much as possible during rain or snow.

Our buildings are pre treated with a water based treatment^{**}; this only helps to protect the product during transit and for up to 3 months against mould. To validate your guarantee and ensure longevity of the product, it is ESSENTIAL the building is treated with a wood preserver within the first three months of assembly and thereafter in accordance with the manufactures recommendations. Care must be taken to ensure the product is placed on a suitable base.

BUILDING A BASE

When thinking about where the building and base is going to be constructed: Ensure that there will be access to all sides for maintenance work and annual treatment.

Ensure the base is level and is built on firm ground, to prevent distortion. Refer to diagrams for the base dimensions, The base should be slightly smaller than the external measurement of the building, i.e. The cladding should overlap the base, creating a run off for water. It is also recommended that the floor be at least 25mm above the surrounding ground level to avoid flooding.

TYPES OF BASE

- Concrete 75mm laid on top of 75mm hard-core.
- Slabs laid on 50mm of sharp sand.

Whilst all products manufactured are made to the highest standards of Safety and in the case of childrens products independently tested to EN71 level, we cannot accept responsibility for your safety whilst erecting or using this product.



All building's should be erected by two adults

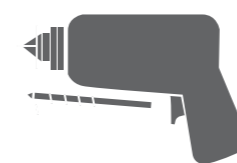

2mm Drill bit

For ease of assembly, it is advisable to pilot drill all screw holes and ensure all screw heads are countersunk.



Winter = High Moisture = Expansion
Summer = Low Moisture = Contraction



CAUTION

Every effort has been made during the manufacturing process to eliminate the prospect of splinters on rough surfaces of the timber. You are strongly advised to wear gloves when working with or handling rough sawn timber.

****Protim Fentex E5****

Biocidal Product Regulation (EU 528/2012) Article 58 Information

Protim Fentex E2 preserved wood is a "treated article" which incorporates biocidal products.
Wood correctly preserved with Protim Fentex E2 is protected against mould in storage.
Contains: IPBC (3-iodo-2-propynyl-N-butyl carbamate) and propiconazole.

Wear gloves when handling freshly treated wood.
Avoid breathing dust when cutting treated or untreated wood.
Dispose of off-cuts responsibly – do not burn.

Overall Dimensions:

Length = 3028mm
 Width = 2484mm
 Height = 2121mm

Base Dimensions:

Length = 3016mm
 Width = 2414mm

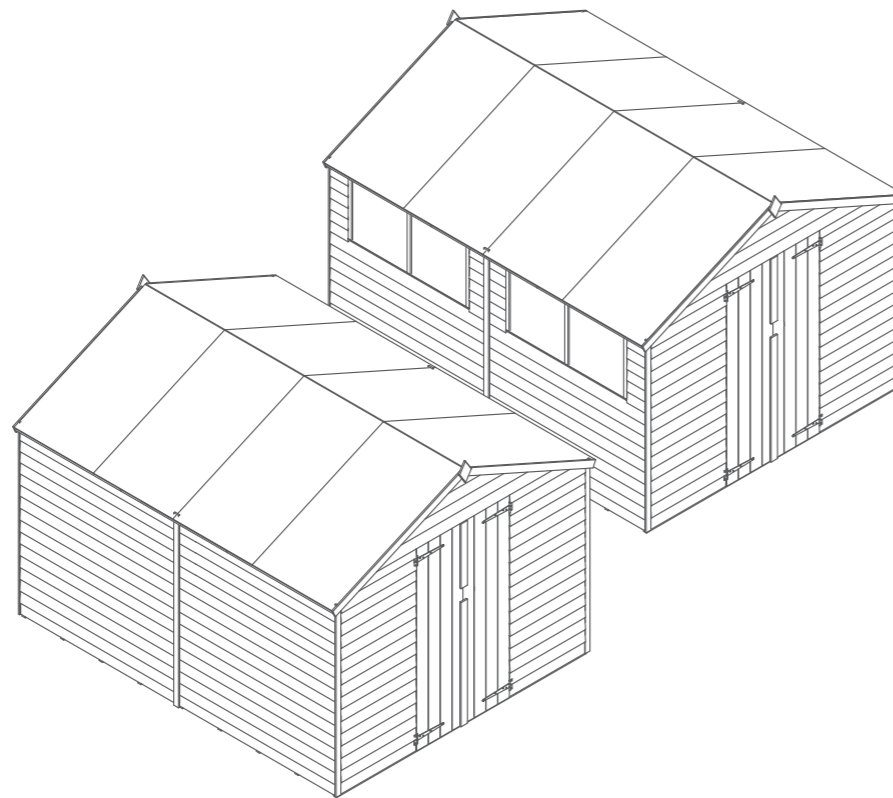

Before assembly please make sure you have a suitable base ready to erect your building

Building content

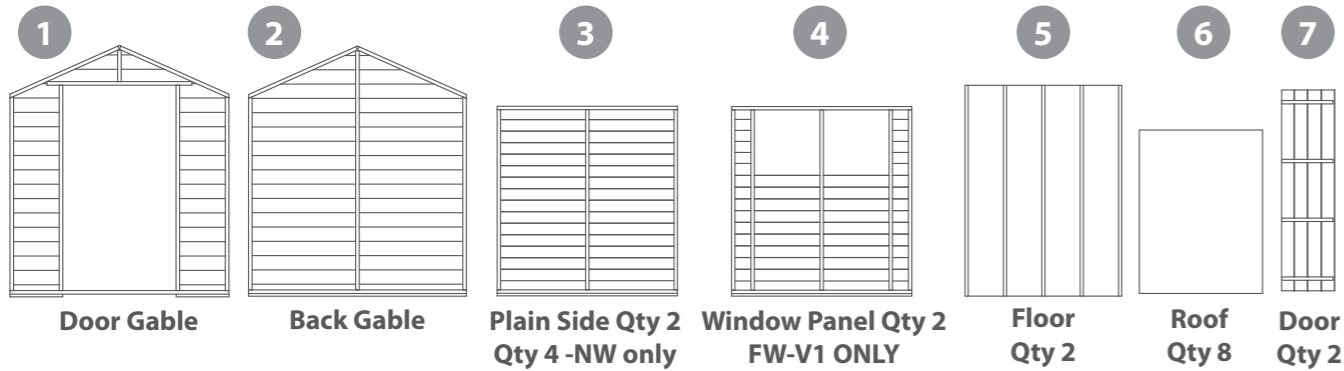

- 8 Ridge Bar - 1462mm Qty 2
- 9 Truss Frame - 1302mm Qty 6
- 10 Truss Support - 490mm Qty 3
- 11 Truss Block - 140mm Qty 6
- 12 Door Block - 140mm Qty 2
- 13 Fascia - 1333mm Qty 4
- 14 Door Strip - 1016mm Qty 1
- 15 Door Strip - 530mm Qty 1
- 16 Cover Trim - 1575mm Qty 6
- 17 Door Beading Strip - 1590mm Qty 2
- 18 Eaves Frame - 1001mm Qty 6
- 19 Window Strip - 546mm Qty 10 - FW Only
- 20 Finial Qty 2
- 21 Felt
- 22 T Hinge Qty 4
- 23 L-Bracket Qty 2
- 24 Turn Button Qty 3
- 25 Plastic Window Cill Qty 2 - FW Only
- 26 U Channel
- 27 Styrene Qty 4 - FW Only

Nail Bag

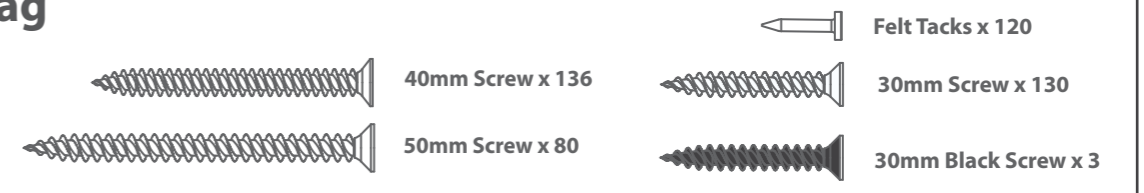

Pre Assembly

Remove transportation blocks from the bottom of each panel before beginning assembly. Each Panel should have two

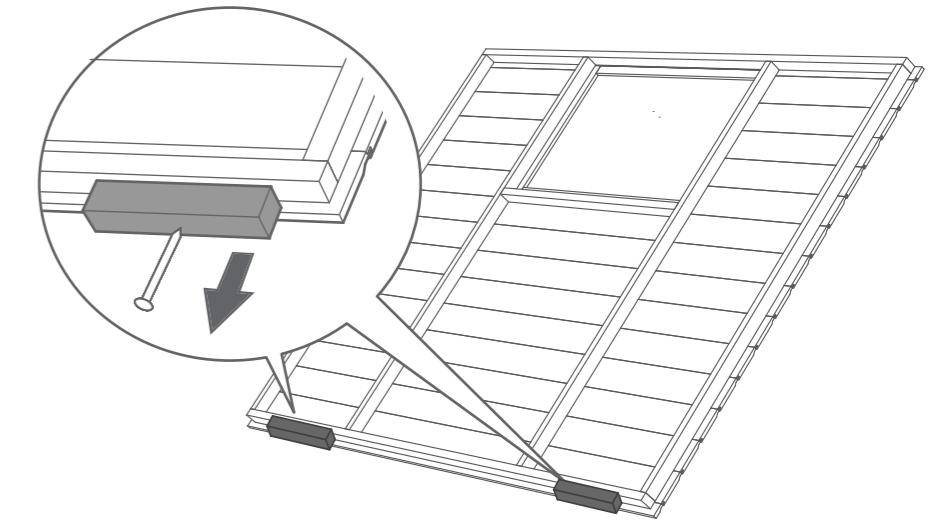

Fix the T Hinges onto the doors and door frame as shown. Ensure that the screws go through the cladding and into the framing behind.

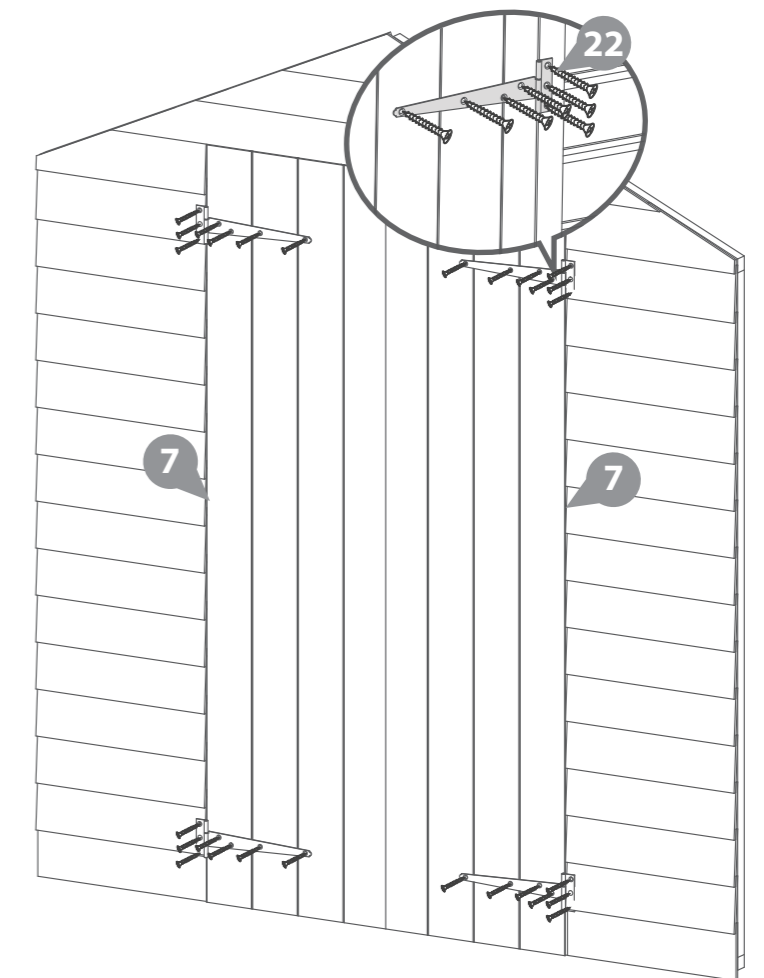
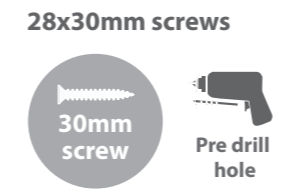

Step 1

Place floor on firm and level base, ensure base has suitable drainage free from areas where water can collect. (See front page on base requirements).

Attach the floors using 12 x 40mm screws

12x40mm screws

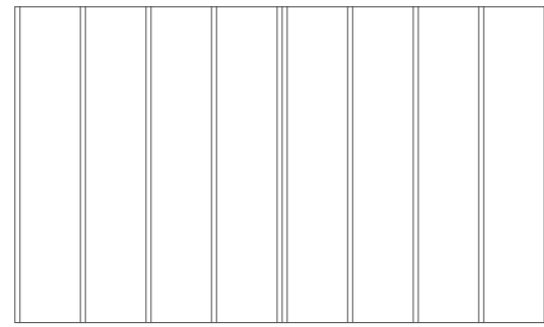
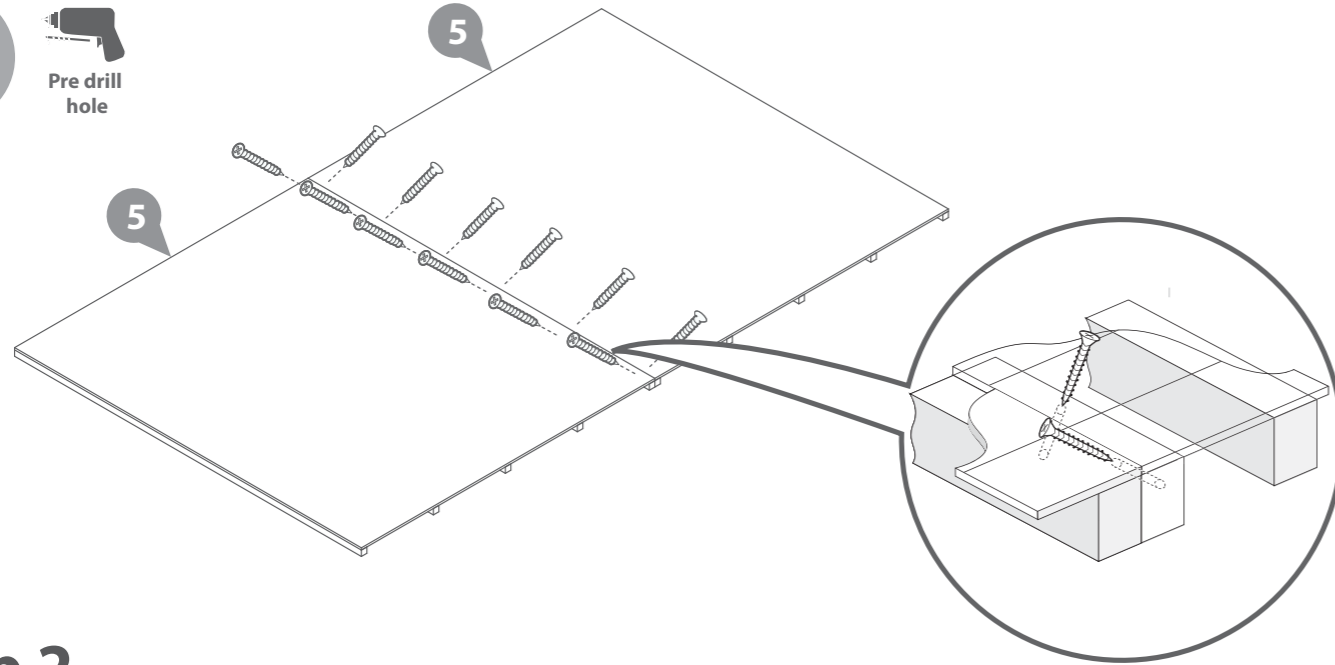
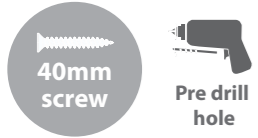

Step 3

Fix the remaining plain side and a window side at the corners with 50mm screws as shown in diagram.

6x50mm Screws

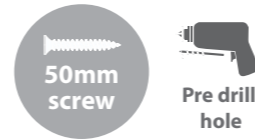

Use **3** for no window buildings

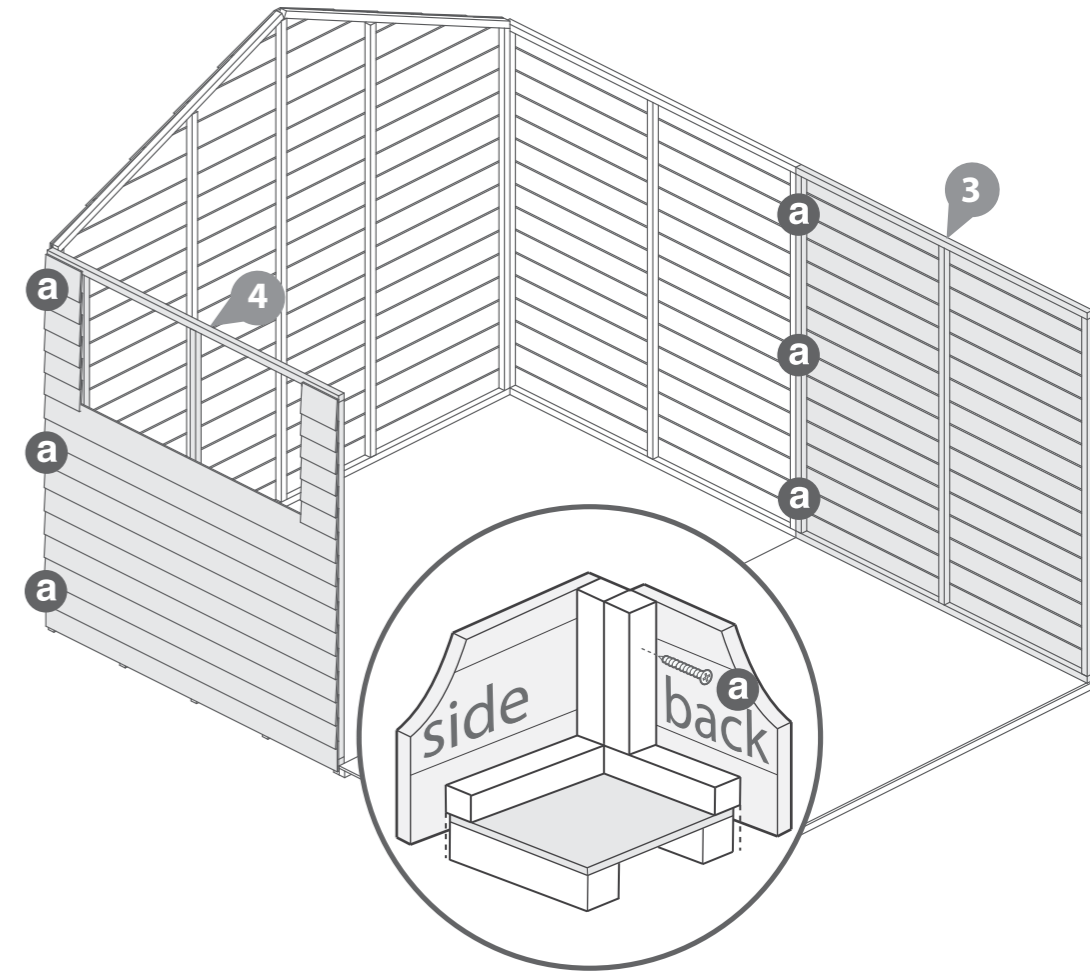

Step 2

a Fix the corners with 50mm screws as shown in diagram.

Position the panels so there is equal spacing between the floor and cladding on all 4 sides

3x50mm Screws

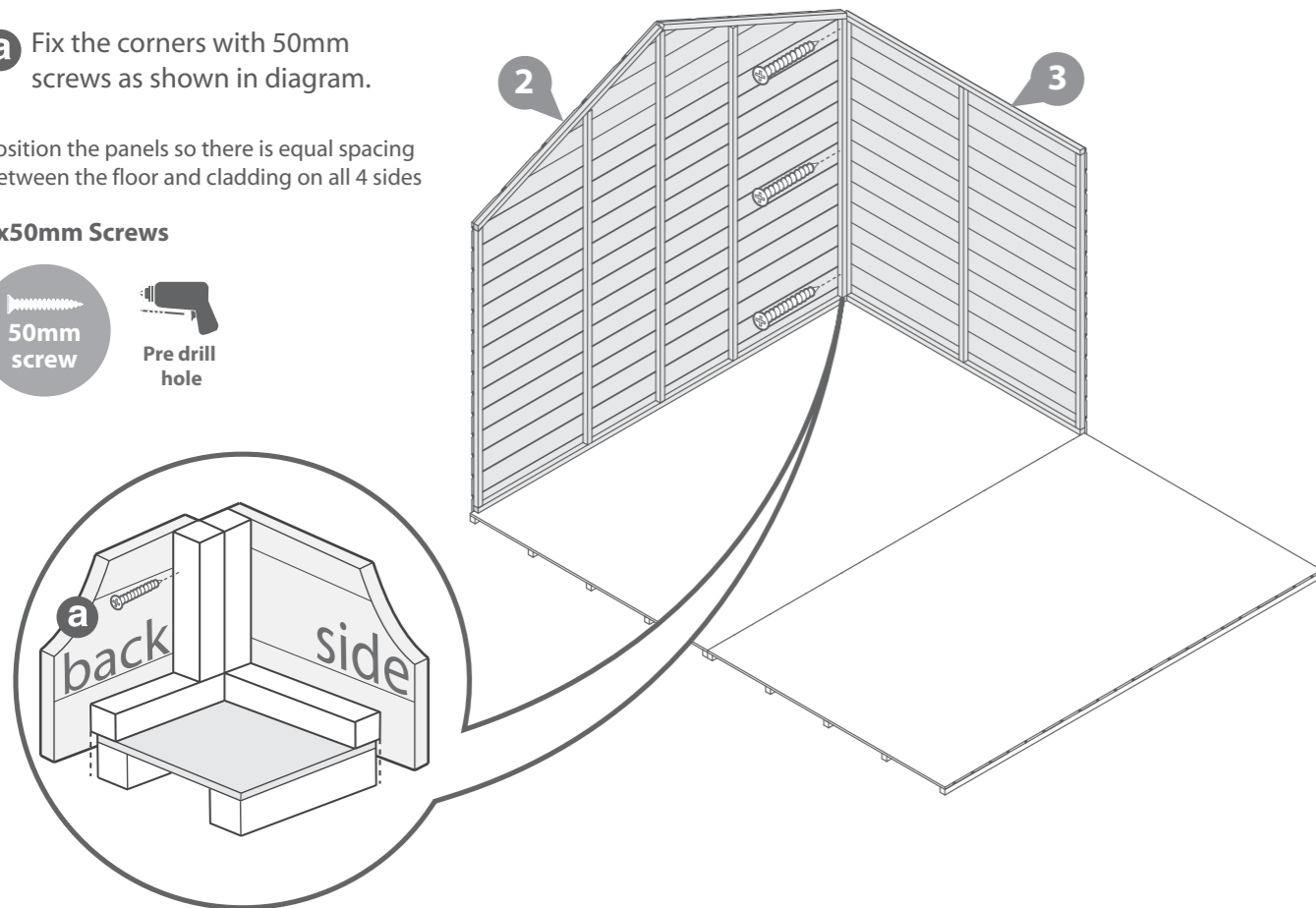
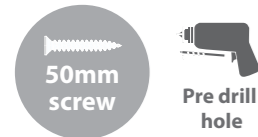

Step 4

Fix the remaining window side and the door gable at the corners with 50mm screws as shown in diagram.

9x50mm Screws

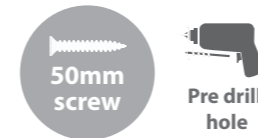

Use **3** for no window buildings

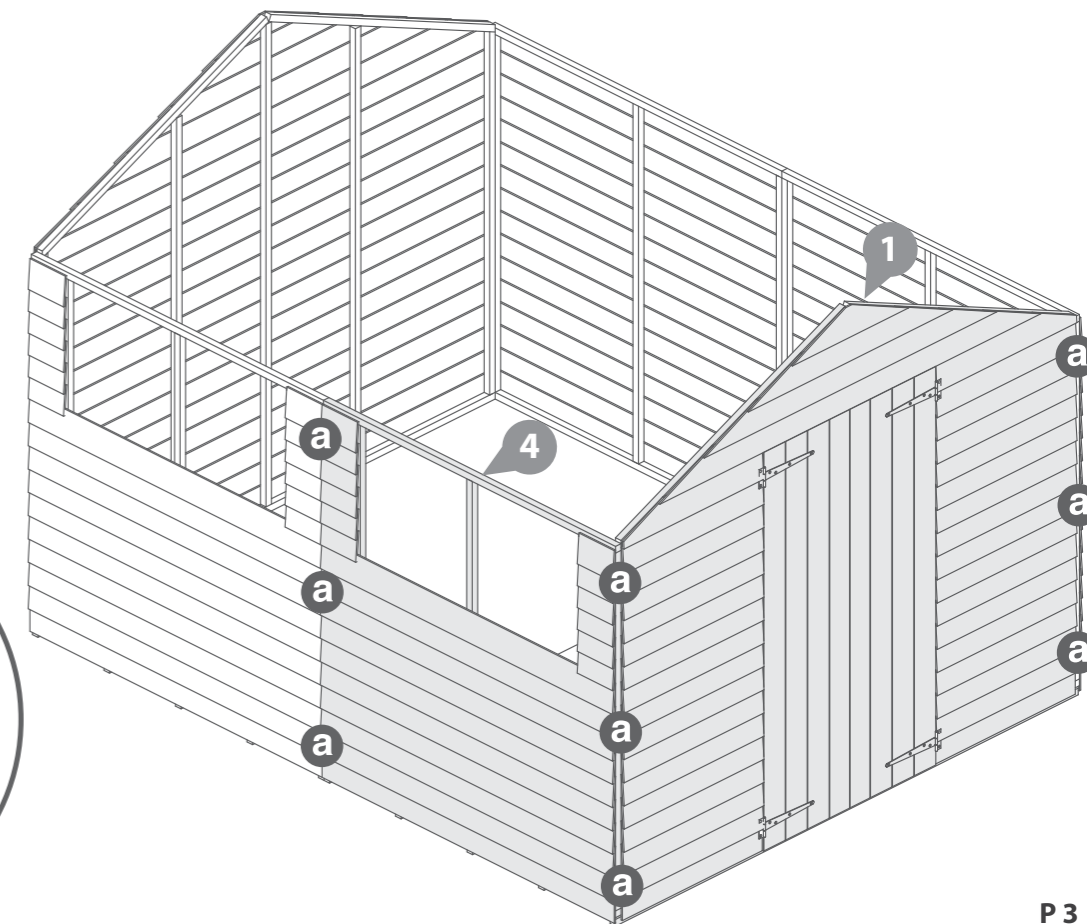
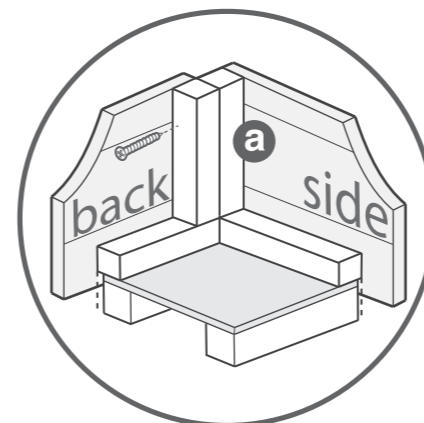

Step 5

Ridge Bar Assembly

Position the two parts of the ridge bar within the 'U' channel and secure from either side with 3 x 30mm screws and 4 x 30mm screws from underneath. Secure an 'L' bracket to either end of the ridge bar using 2 x 30mm screws per bracket.

Place the roof support bar in between the front and back panels. Ensure the top corners of the support bar are flush with each top point. Secure in place using the L Bracket on each end with 4x30mm screws.

18x30mm Screws

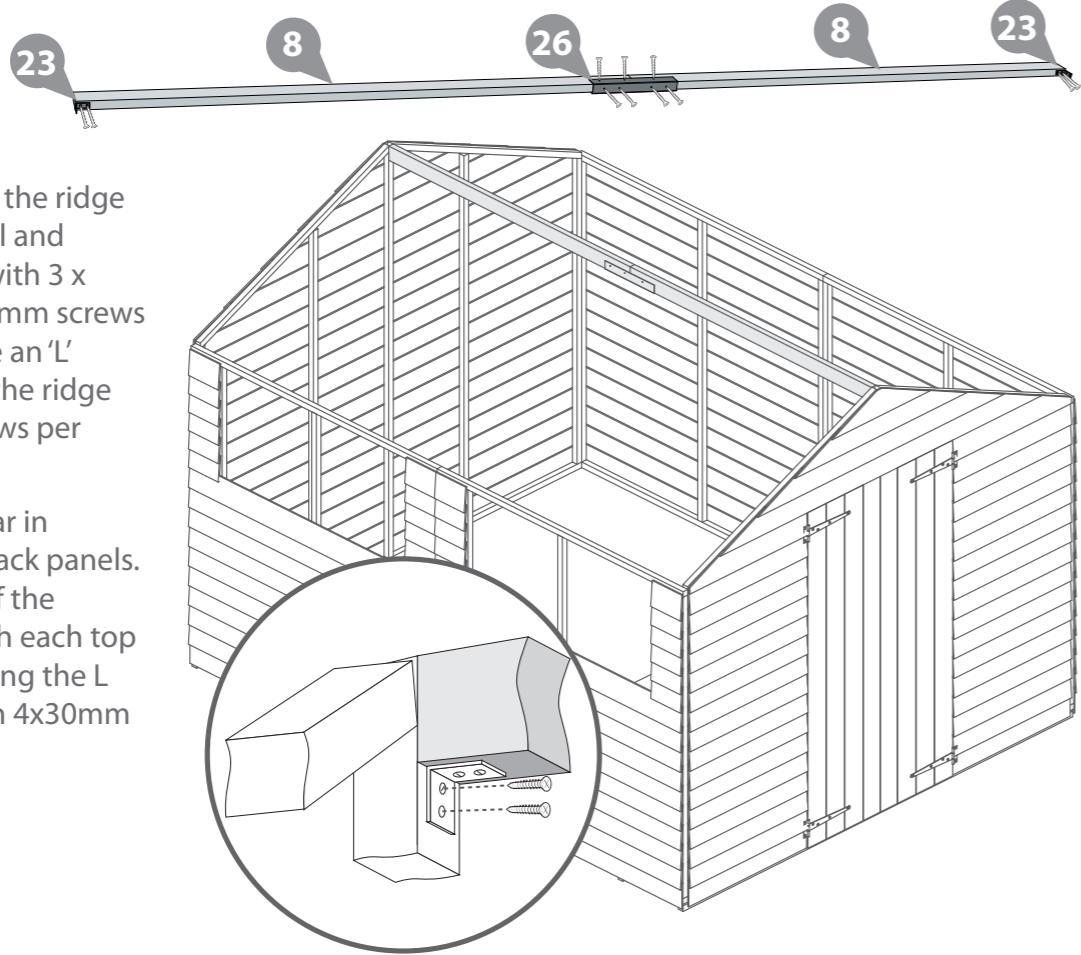

Step 6

i) Position a truss frame to the ridge bar sloping down towards the building side, ensure it is central to the middle upright of the panel. Fix with a 50mm screw through the ridge bar into the truss frame.

ii) Align the second truss frame with the first on the opposite side of the ridge bar and fix with a 50mm screw at an angle as illustrated.

2x50mm Screws

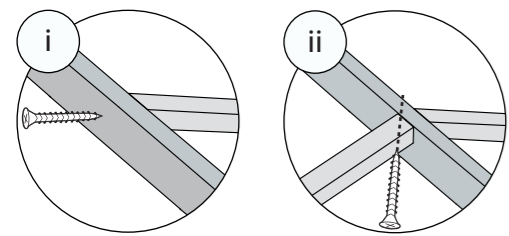

ENSURE SUPPORT BARS ARE MANUALLY SUPPORTED UNTIL FIXED AT BOTH ENDS

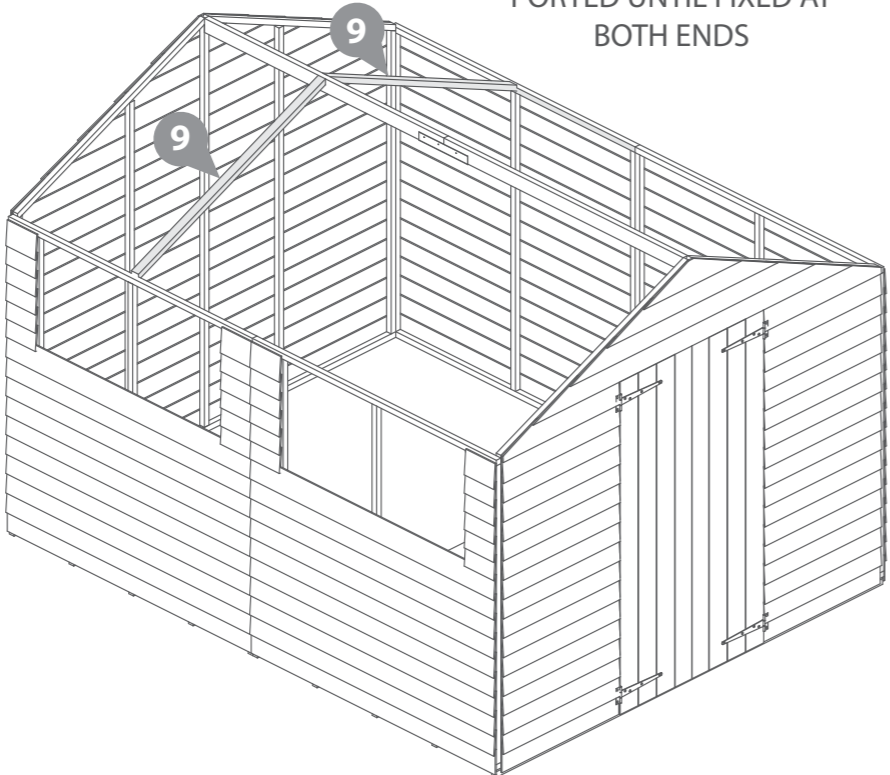

Step 7

i) Fix the truss block to the side panel framing with 2 x 50mm screws. Position the block at the top of the framing with the angle pointing upwards into the building, aligning the block centrally along the join between the side panels with one screw in each panel.

ii) Fix the support bar to the block using 1 x 50mm screw.

6x50mm Screws

i **ii**

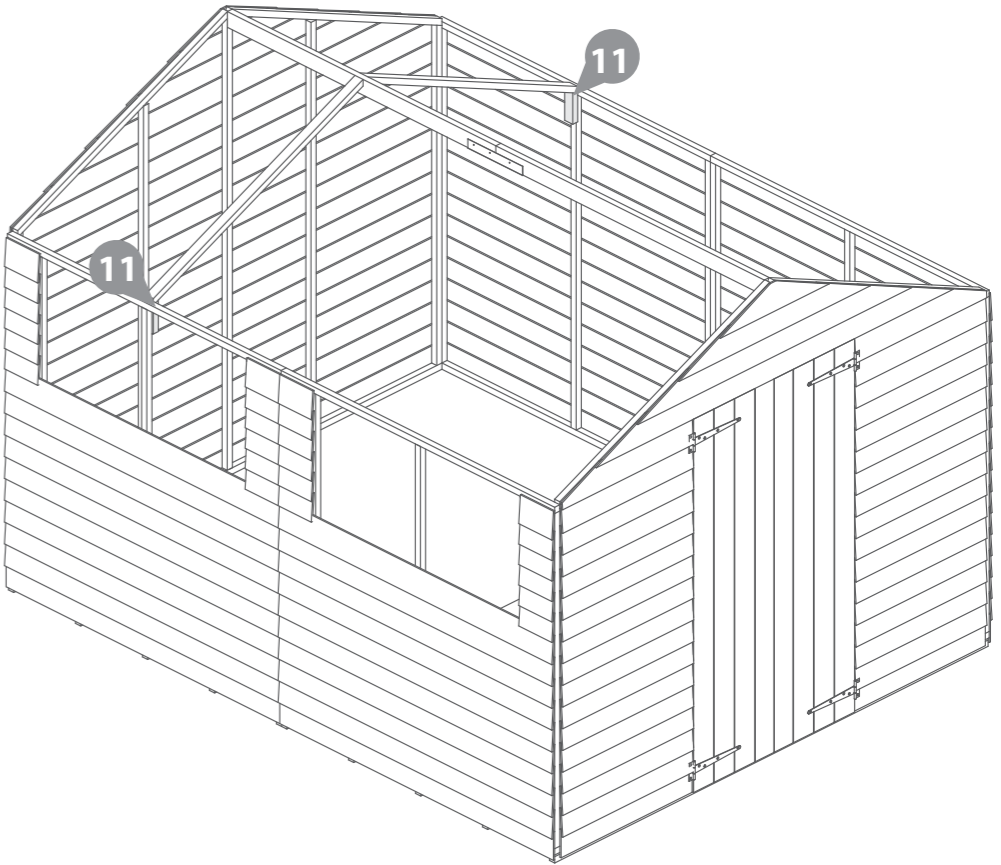

Step 8

Fix a Truss support between the two truss frames and fix in place using 40mm screws, ensure you pre-drill holes before fixing together.

4x40mm Screws

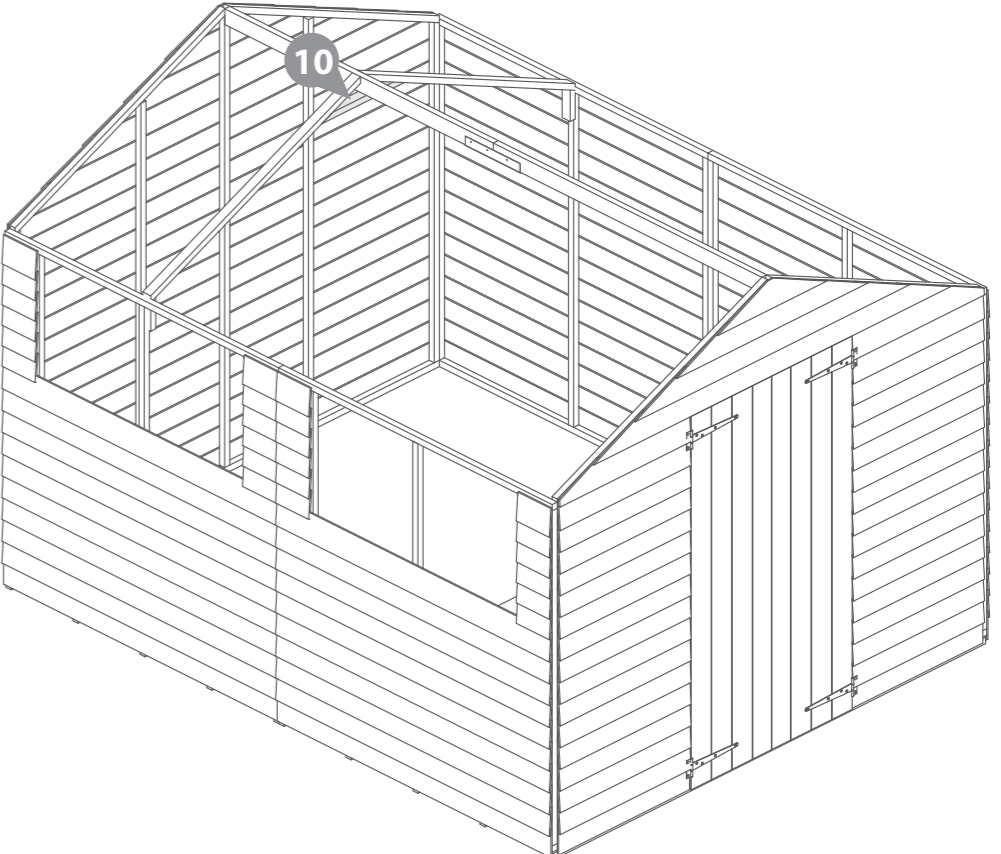
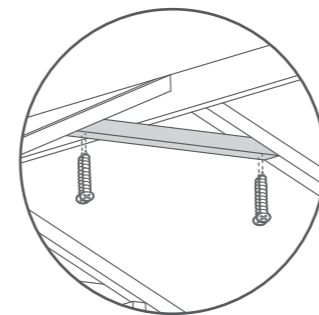

Step 9

a Place two roof sheets on top of the plain gable and truss making sure the roof sheet sits flush to the outside edge of the plain gable and fix using 40mm screws. Before fixing the roof sheet to the truss frame make sure the edge of the roof sheet sits in the middle of the truss frame then fix using 40mm screws.

20x40mm Screws

b Fix the eaves frame to the roof sheet using 3x30mm screws for each sheet.

6x30mm Screws

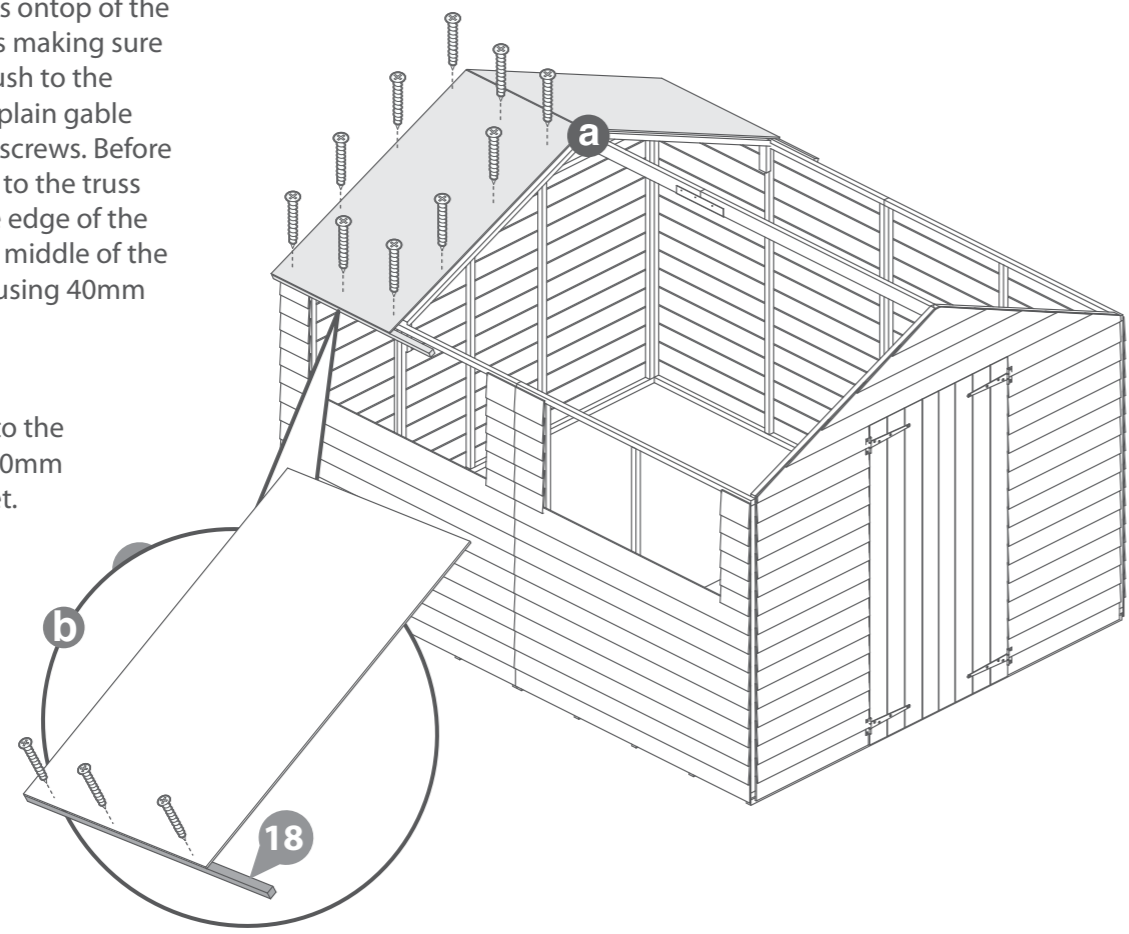

Step 10

Attach another truss in the centre of the building the same way as shown in step 6 through to 8.

8x50mm Screws
4x40mm Screws

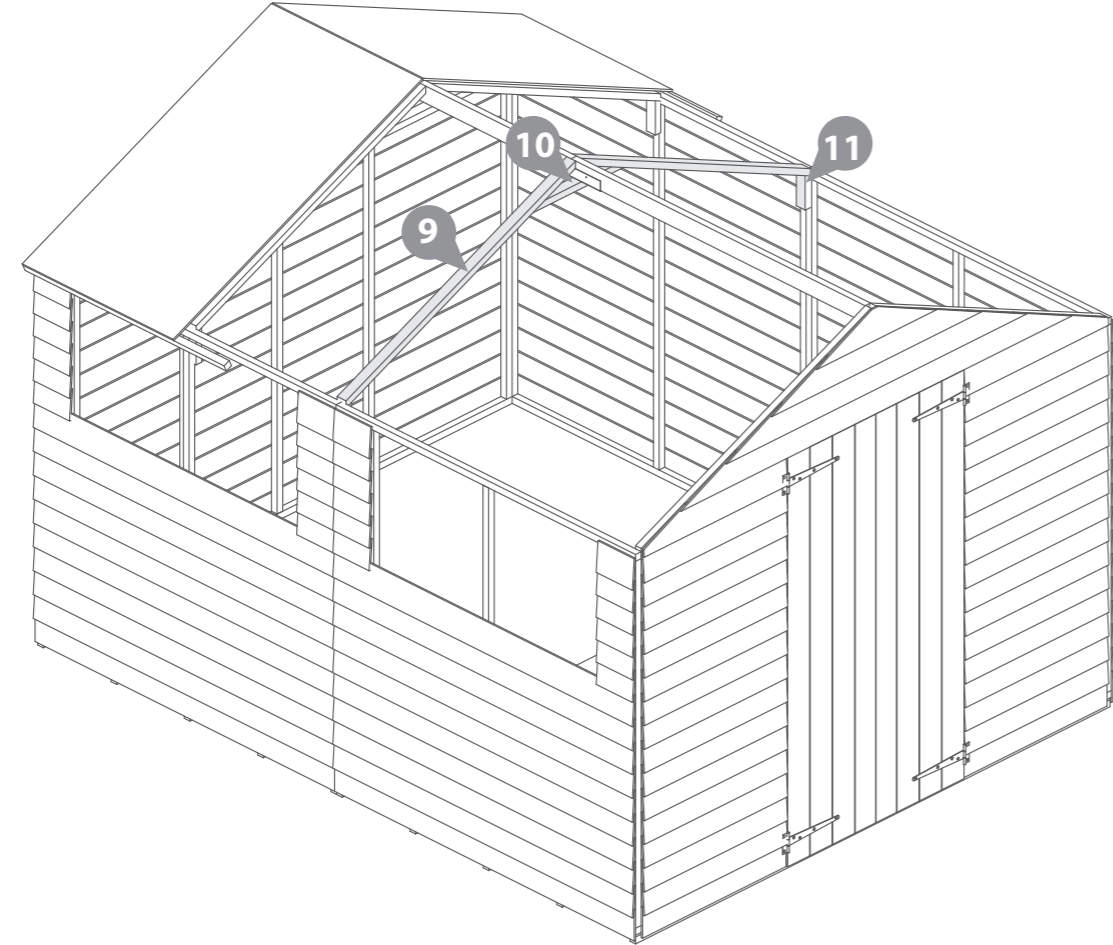

Step 11

Attach another two roof sheets on top of the two truss's in the same way as stated in step 9a ensuring that the roof sheets sits half way onto each truss frame.

20x40mm Screws

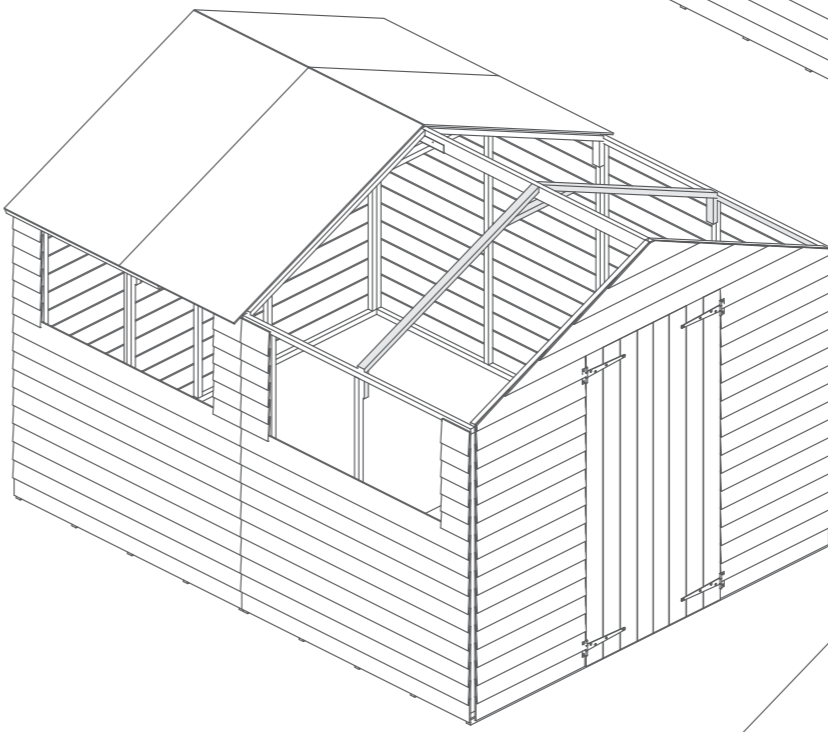

Attach another truss in the centre of the building the same way as shown in step 6 through to 8.

8x50mm Screws
4x40mm Screws

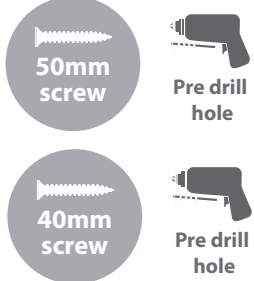

Attach another two roof sheets on top of the two truss's in the same way as stated in step 9a ensuring that the roof sheets sits half way onto each truss frame.

20x40mm Screws

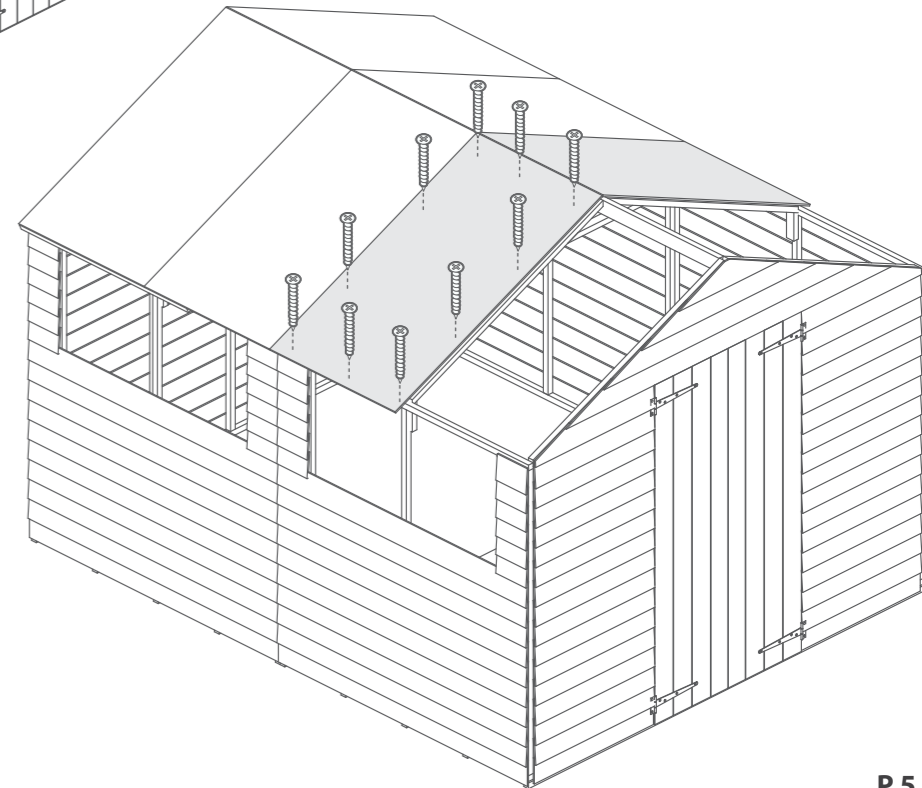
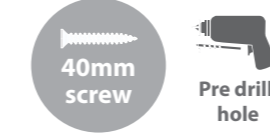

Step 11 con...

Attach another roof sheet ontop of the truss in the same way as stated in step 9a usig 20x40mm screws.

Then fix the eaves frame to the roof using 3x30mm screws on each eave.

20x40mm Screws
6x30mm Screws

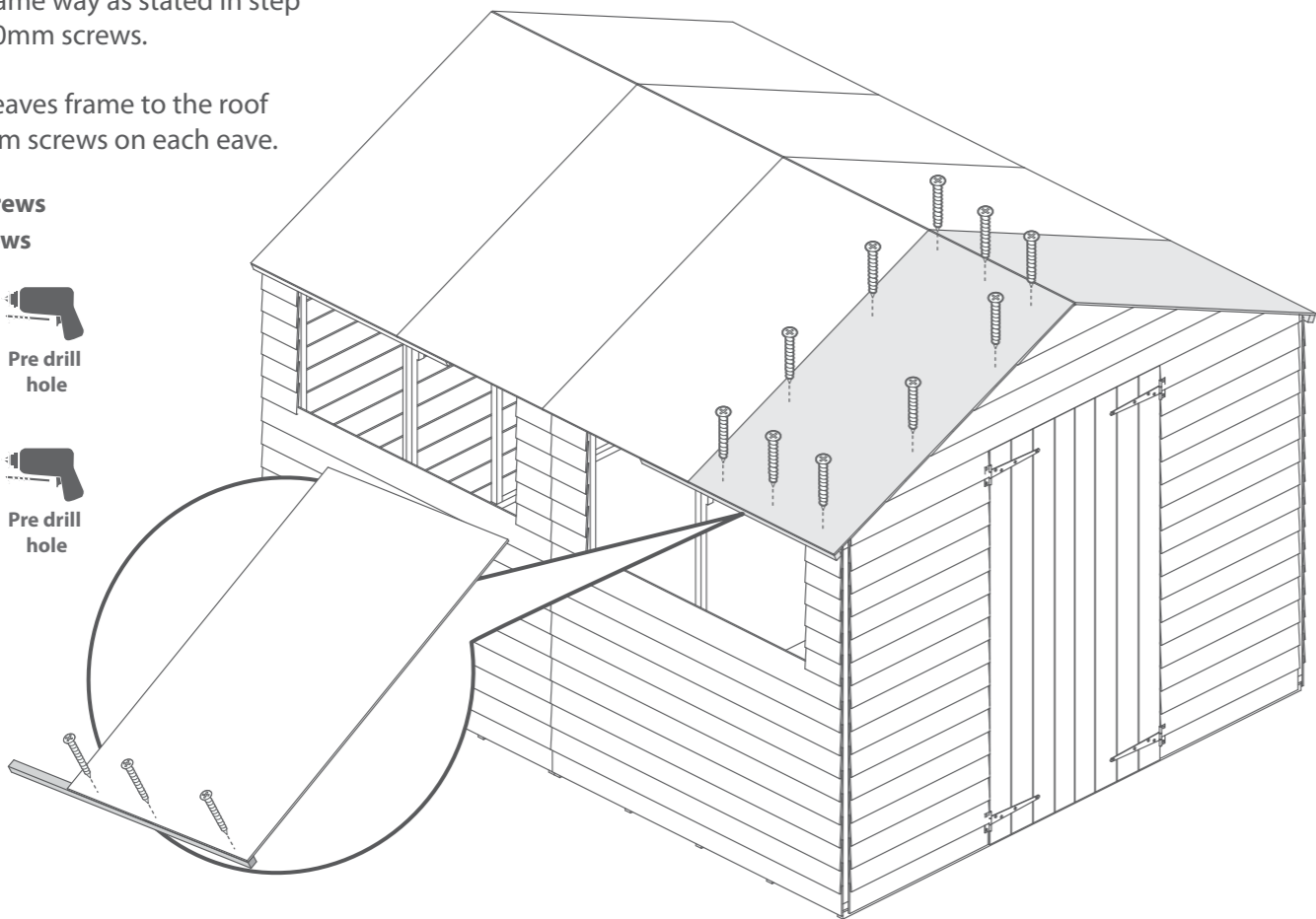
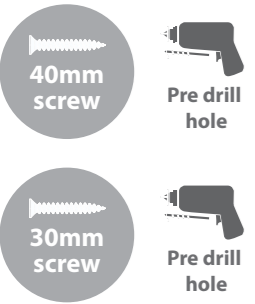

Fix the final eaves frame to the roof sheet using 3x30mm screws for each sheet.

12x30mm Screws

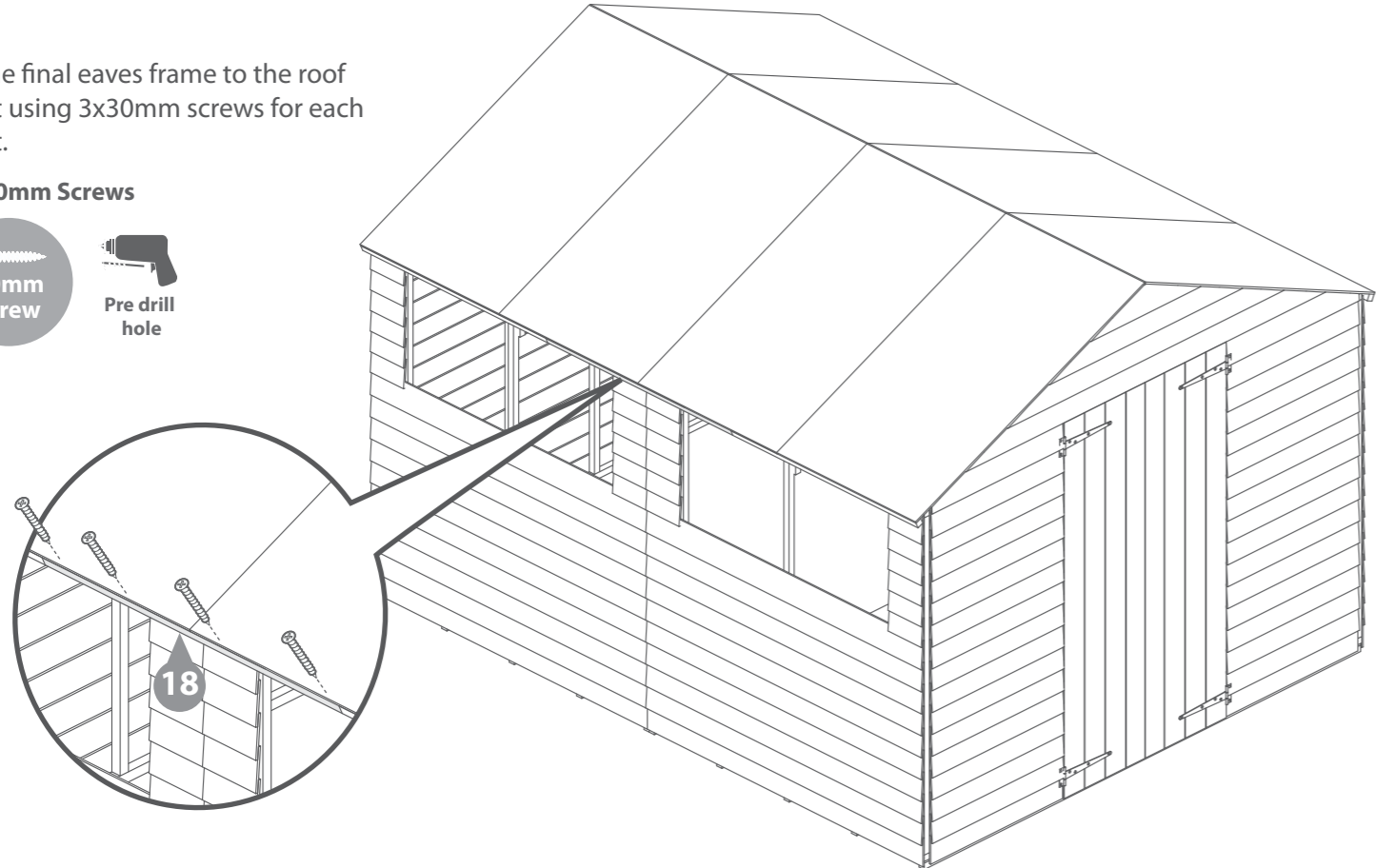

Step 12

Once the roof is fixed attach the building to the floor with 50 mm screws.

24 x 50mm Screws

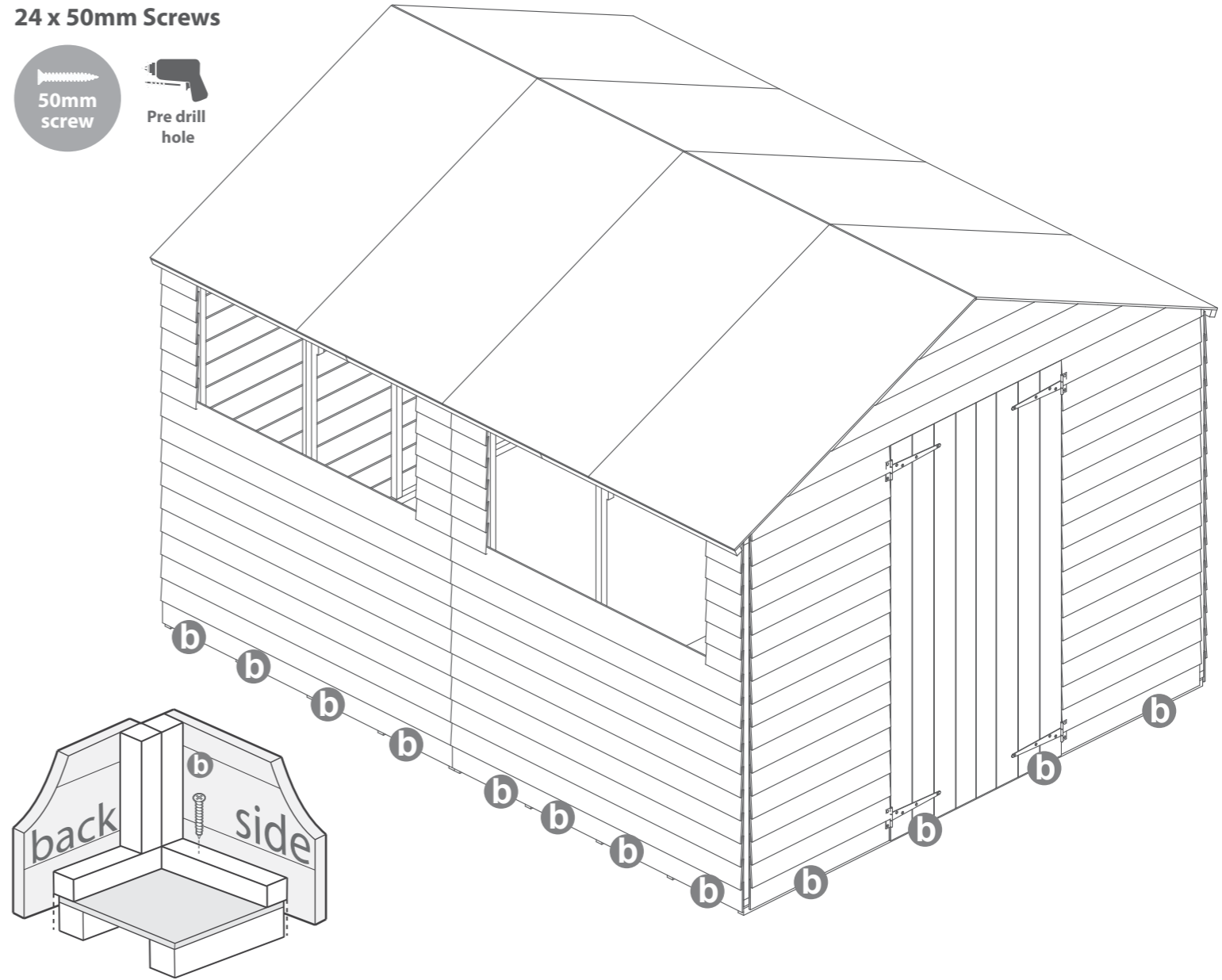
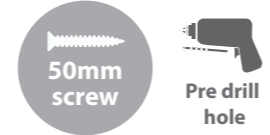

Step 13

Cut out three strips of 3204mm felt and place onto the roof.

Place the felt flat onto the roof in the order that is stated on the diagram below.

Once the sheets are laid out fix them onto the roof with tacks 100mm apart.

132 x Tacks

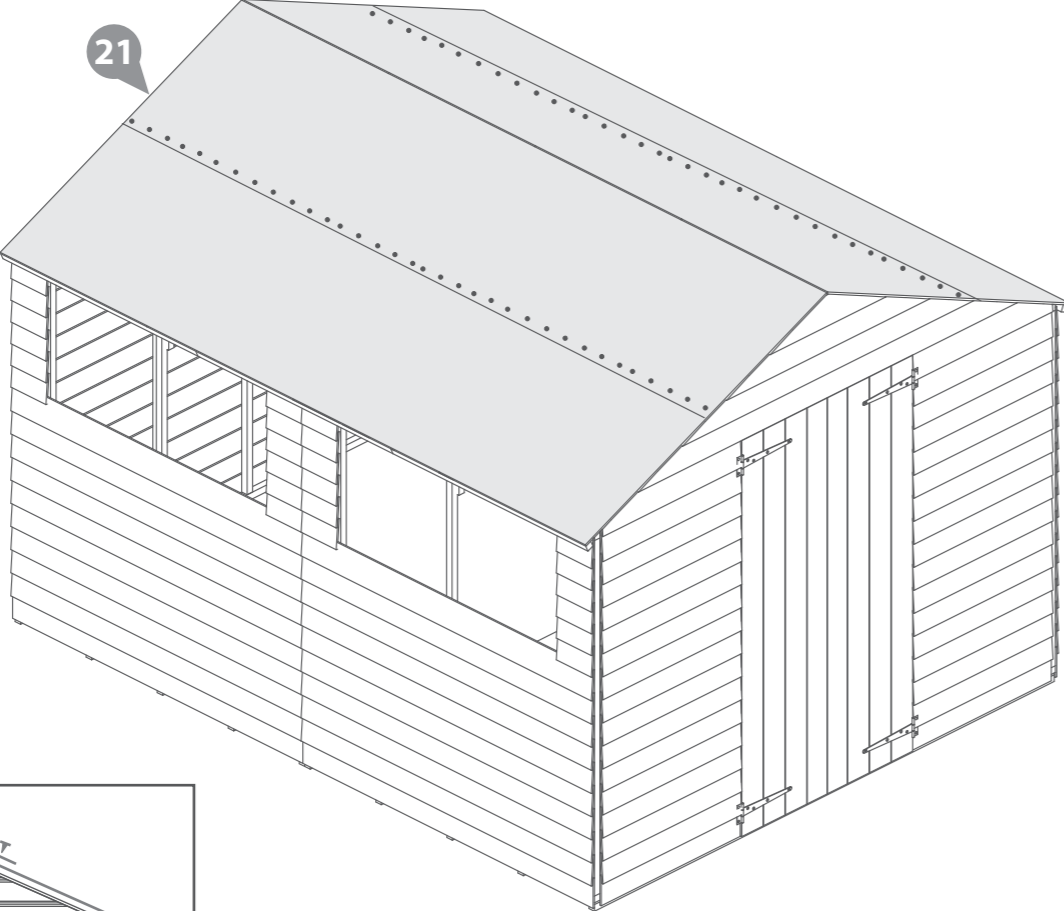
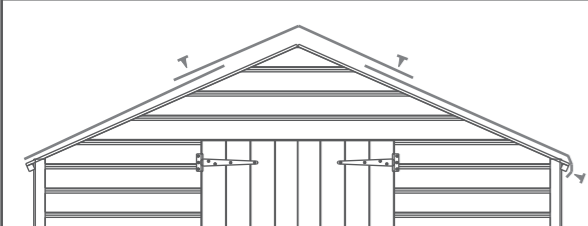

Step 14

Fit the cover trims to the building and secure in place with 40mm screws as shown. Pre drill to avoid splitting.

18x40mm Screws

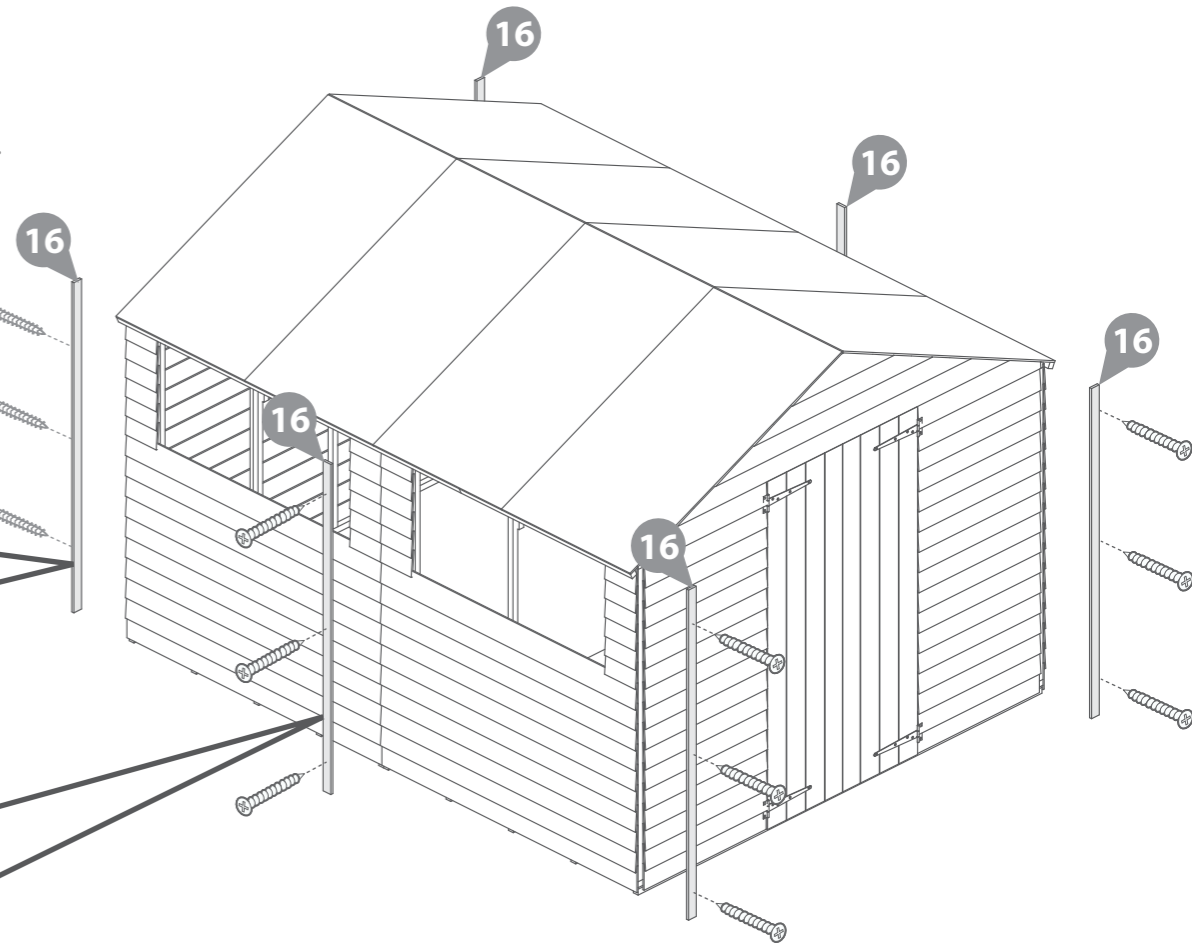
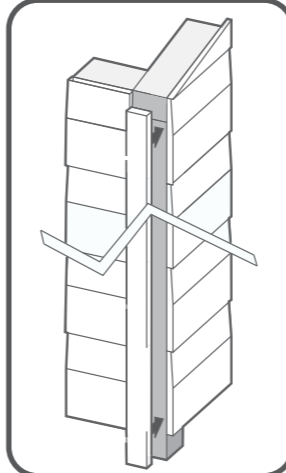
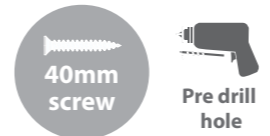

Step 15

Attach fascia's to the roof leaving a slight overhang at the top..

Fit the fascias to the roof over the felt and secure in place with 40mm screws as shown. Pre drill to avoid splitting.

16x40mm Screws

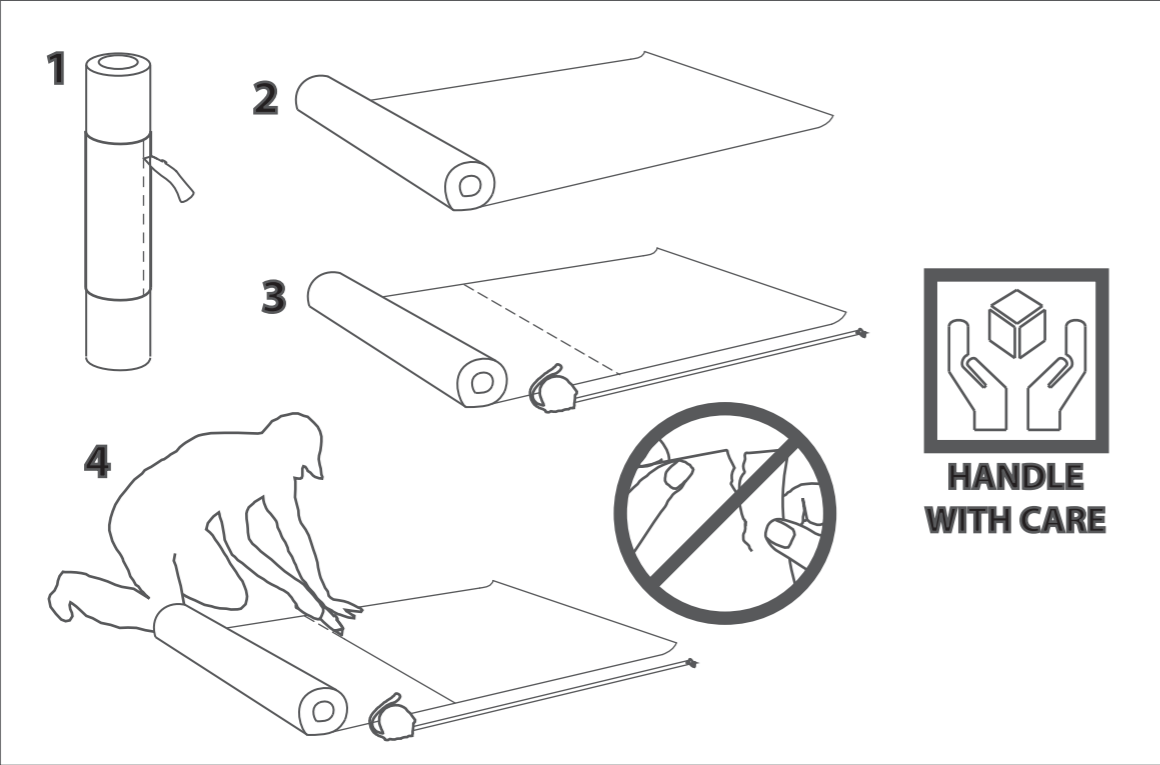
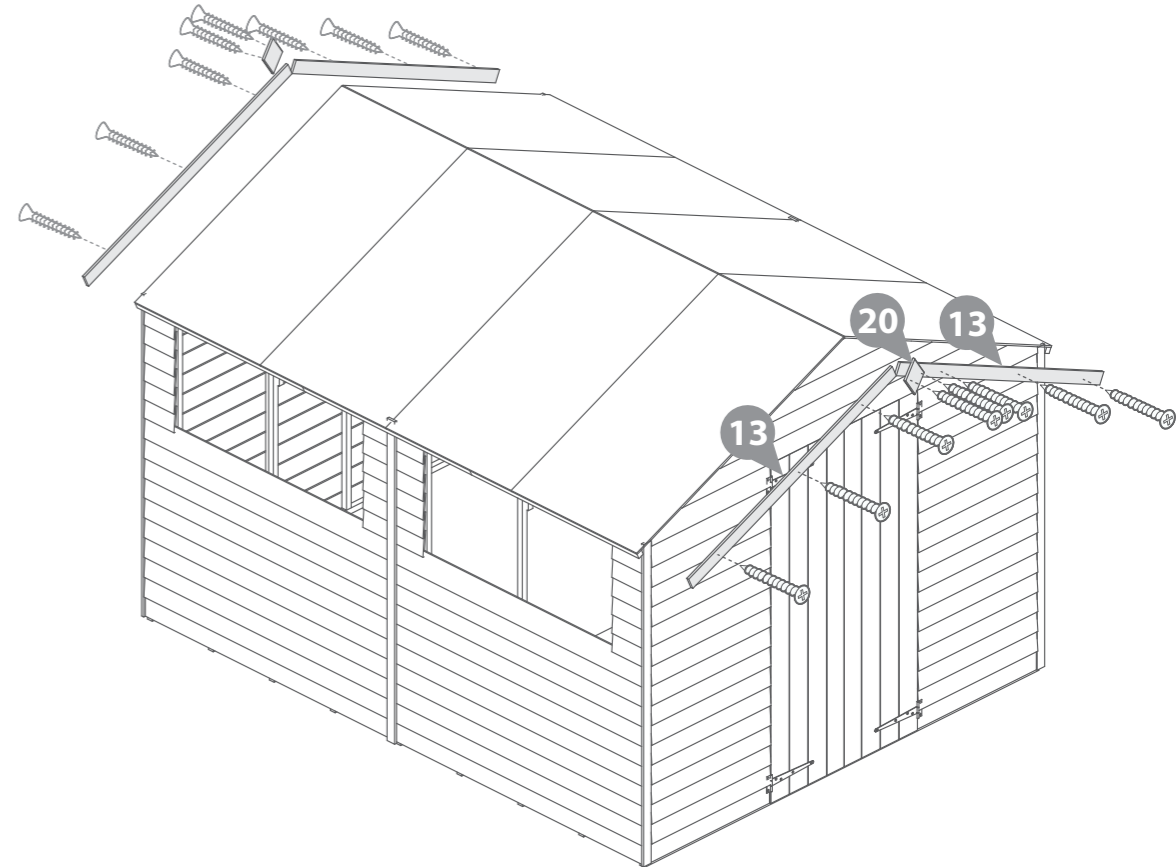
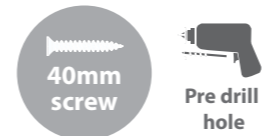

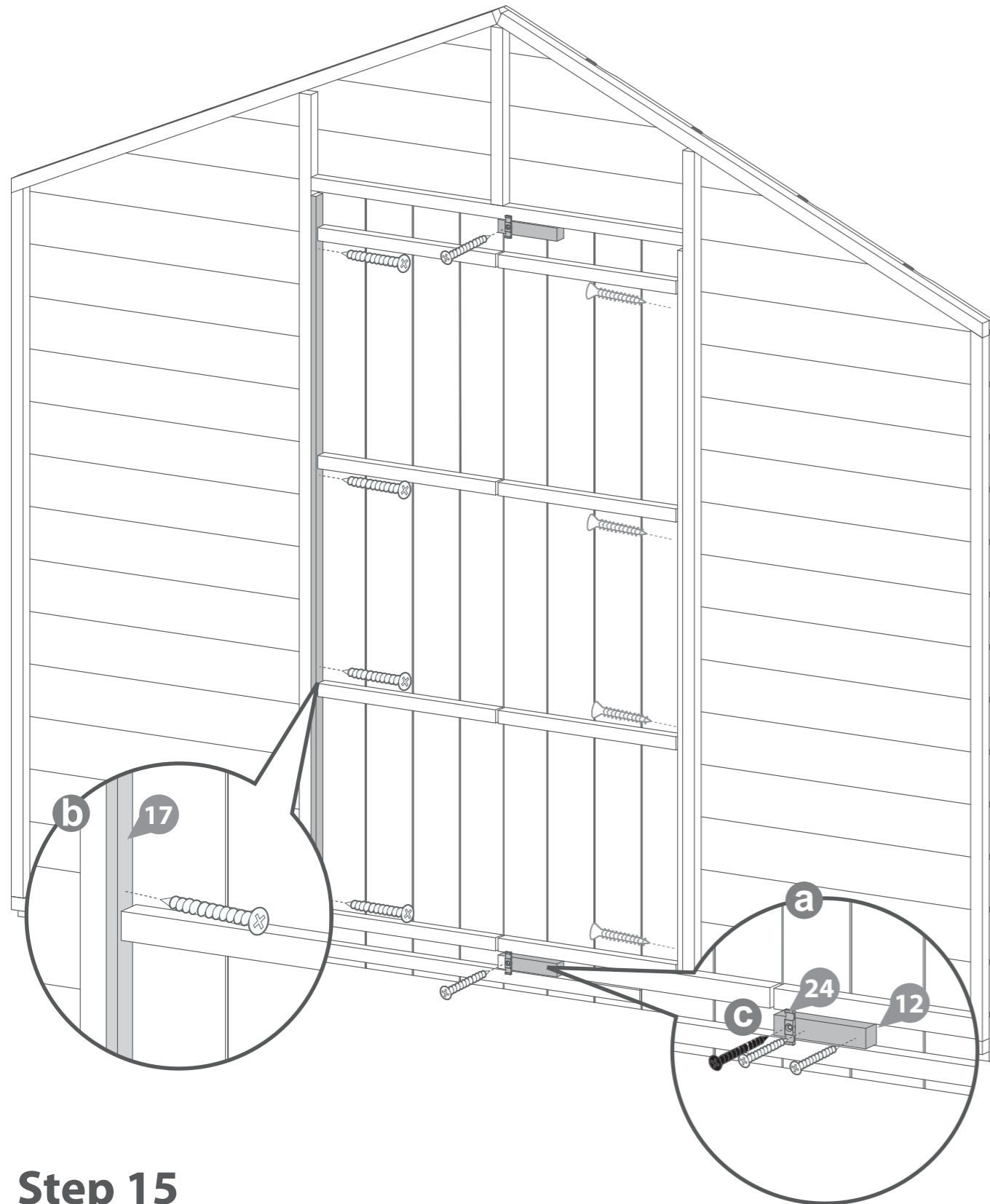

Step 15

- a** First line up the door blocks on top of the framing of the doors. Then fix with 2x30mm screws by screwing through the matchboard door into the block.
6x30mm Screws
- b** Use 4x30mm Screws to fix each beading strip onto the door gable. Ensure that the screw is parallel with the strip when fixing the strip to the door gable as shown in the close up view.
8x30mm Screws
- c** Attach the turn button to the top and bottom door blocks with 1x30mm screw for each one.
2x30mm Black Screws

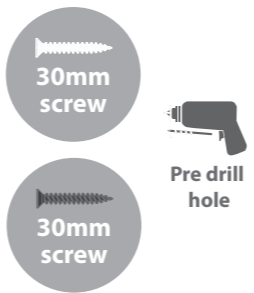

Step 16

- a** Fix the door strips to the master door using 5x30mm screws. If the strips are attached to the slave door the doors will not open properly.
5x30mm Screws
- b** Use 1x30mm screw to secure the turn button to the master door.
1x30mm Black Screws

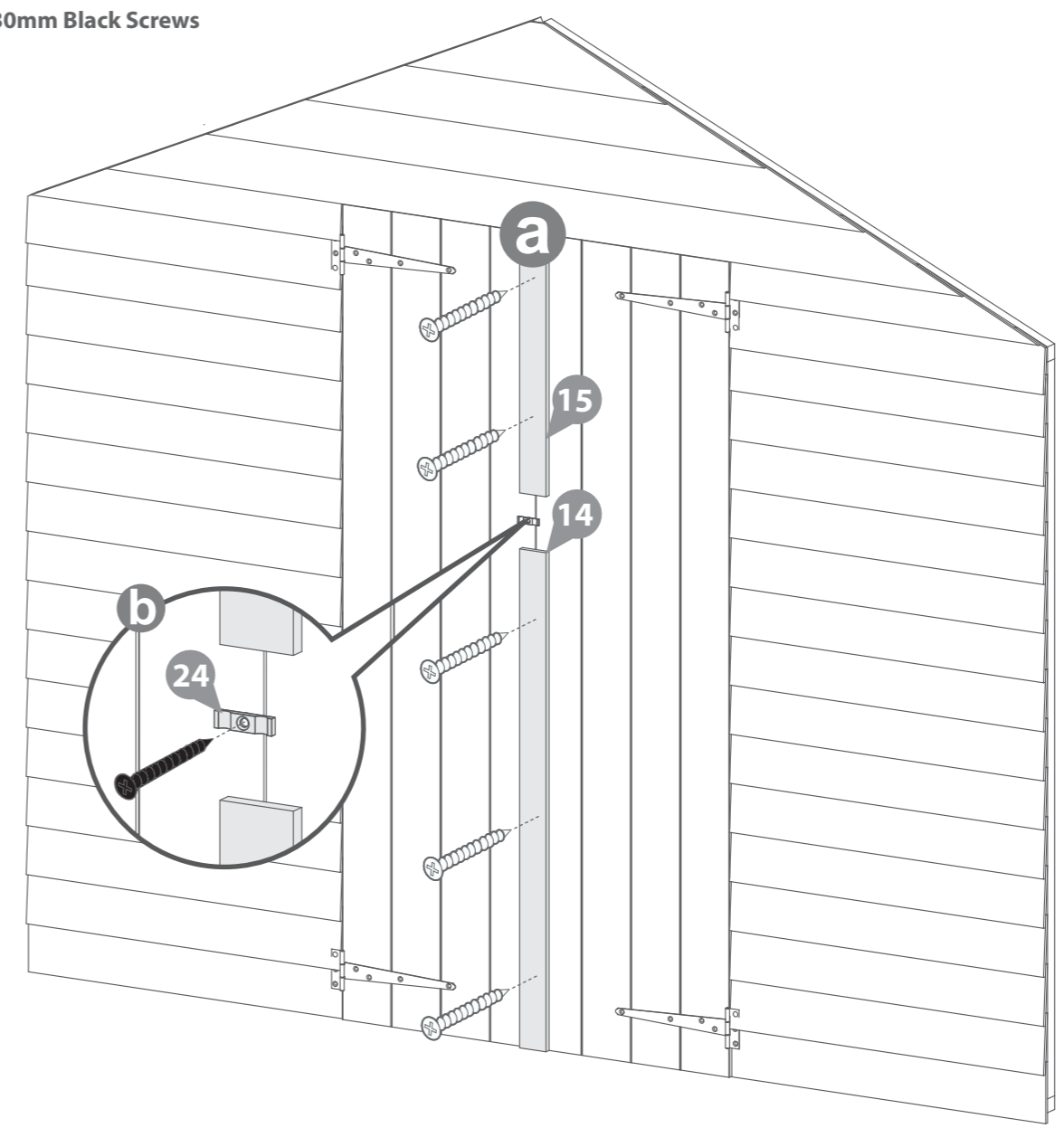
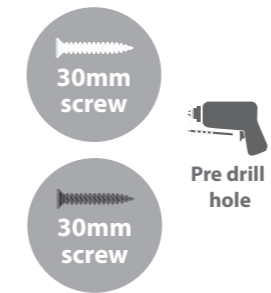

Step 17

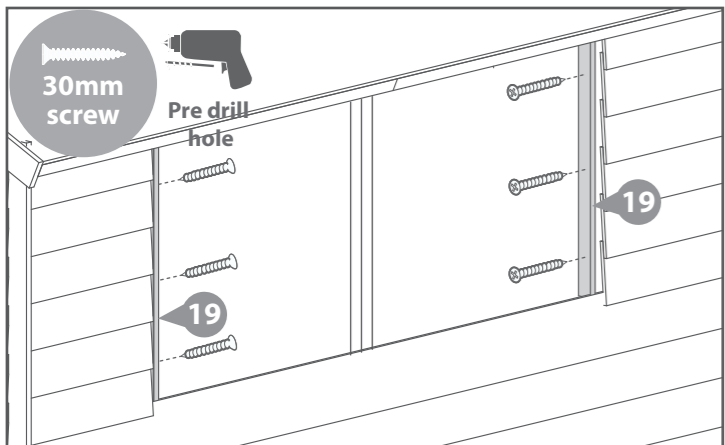

Fix the window strips to the two pieces of framing that sit alongside the outside edges of the window with 3x30mm screws for each strip.

6x30mm Screws

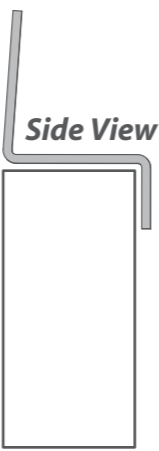
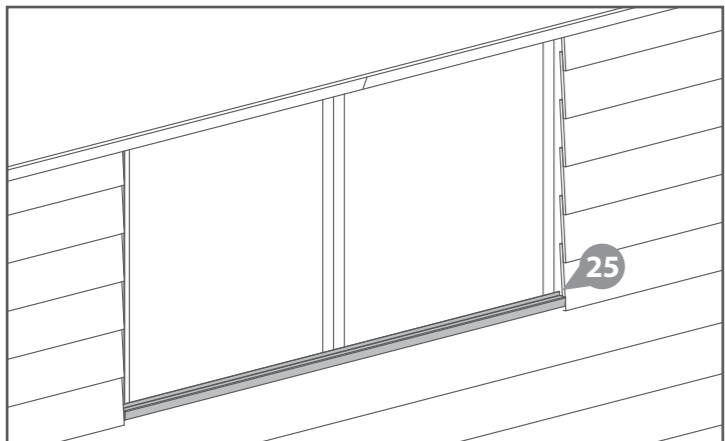

Side View
Place the plastic window cill onto the Window Panel in the same way as shown on both diagrams to the left.

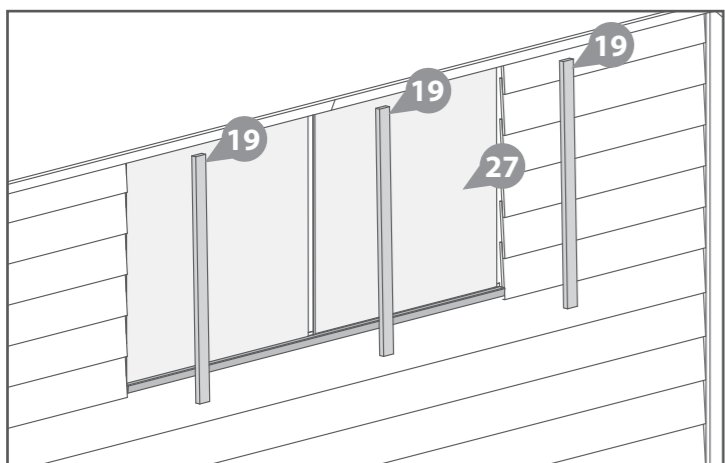

Fit the styrene sheets on top of the window cill.

When positioning the styrene sheets ensure there is an equal distance between them and at either side of the windows.

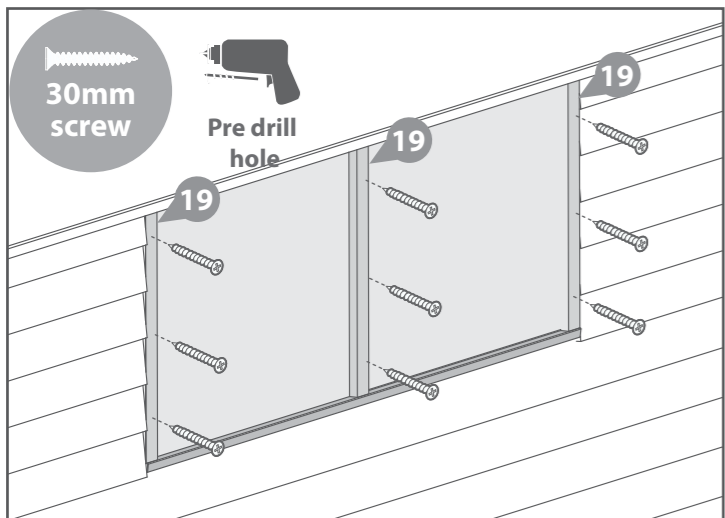

Attach the three window strips at either side of the windows using 3x30mm screws each. Make sure the screws enter the framing in the window panel and not the styrene.

9x30mm Screws



It is ESSENTIAL that you apply wood treatment immediately after the building has been assembled.

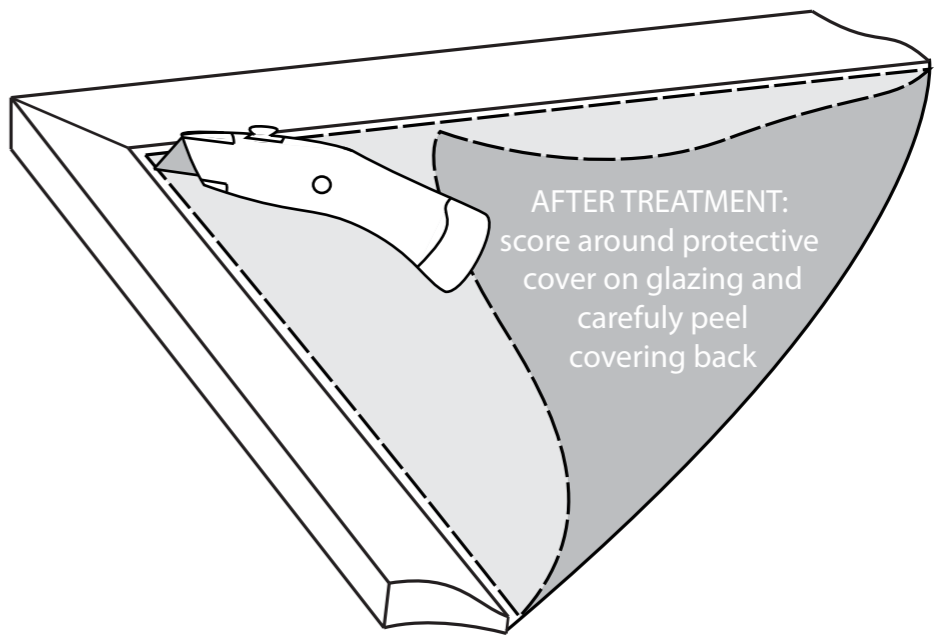

AFTER TREATMENT:
score around protective cover on glazing and carefully peel covering back