

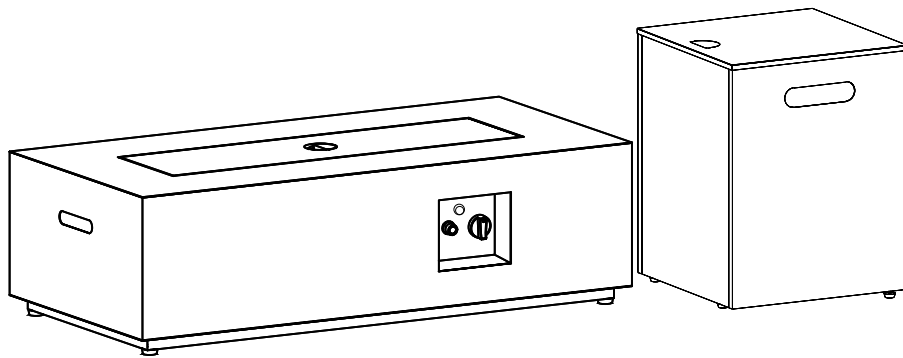

# Outdoor Fire Pit Instruction and Owners Manual

Item # : FP10424

Model # : RS-R42003



## **WARNING** **FOR YOUR SAFETY**

1. Improper installation, adjustment, alteration, service or maintenance can cause injury or property damage.
2. Read the installation, operation, and Maintenance instructions thoroughly before installing or servicing this equipment.
3. Failure to follow these instructions could result in fire or explosion, which could cause property damage, personal injury, or death.

## **WARNING**

For Outdoor Use Only

## **WARNING**

This product can expose you to chemicals including carbon monoxide which is known to the State of California to cause birth defects or other reproductive harm. For more information go to [www.P65Warnings.ca.gov](http://www.P65Warnings.ca.gov).



**Electronic ignition.**  
**Requires (4) AA.**  
(Not Included)



## **ATTACH YOUR RECEIPT HERE**

Keep a copy of your proof of purchase or order confirmation which will be needed if you need to contact us about warranty coverage.

Purchase Date: \_\_\_\_\_



## **Questions, problems, missing parts?**

*Before returning to your retailer, contact our exceptional customer service.*

Contact us by email at [customer care@jrhome.com](mailto:customer care@jrhome.com) or call us toll-free at (800) 561-5550, 7:30 a.m. – 4:00 p.m., PST, Monday – Friday .

## TABLE OF CONTENTS

Table of Contents/Before You Begin	Page 2
Package Contents	Page 3
Safety Information	Page 4
Assembly	Page 5-8
Operation	Page 9
Care and Maintenance	Page 10
Trouble Shooting	Page 11-12
Warranty Information	Page 13
Warranty And Reviews	Page 14



### BEFORE YOU BEGIN

Please read and understand this entire manual before attempting to assemble, operate or install this appliance.

This manual contains important information about the assembly, operation and maintenance of this appliance. General safety information is presented in the first few pages and is located throughout this manual. Keep this manual for future reference and to educate new users of this appliance.

# PACKAGE CONTENTS

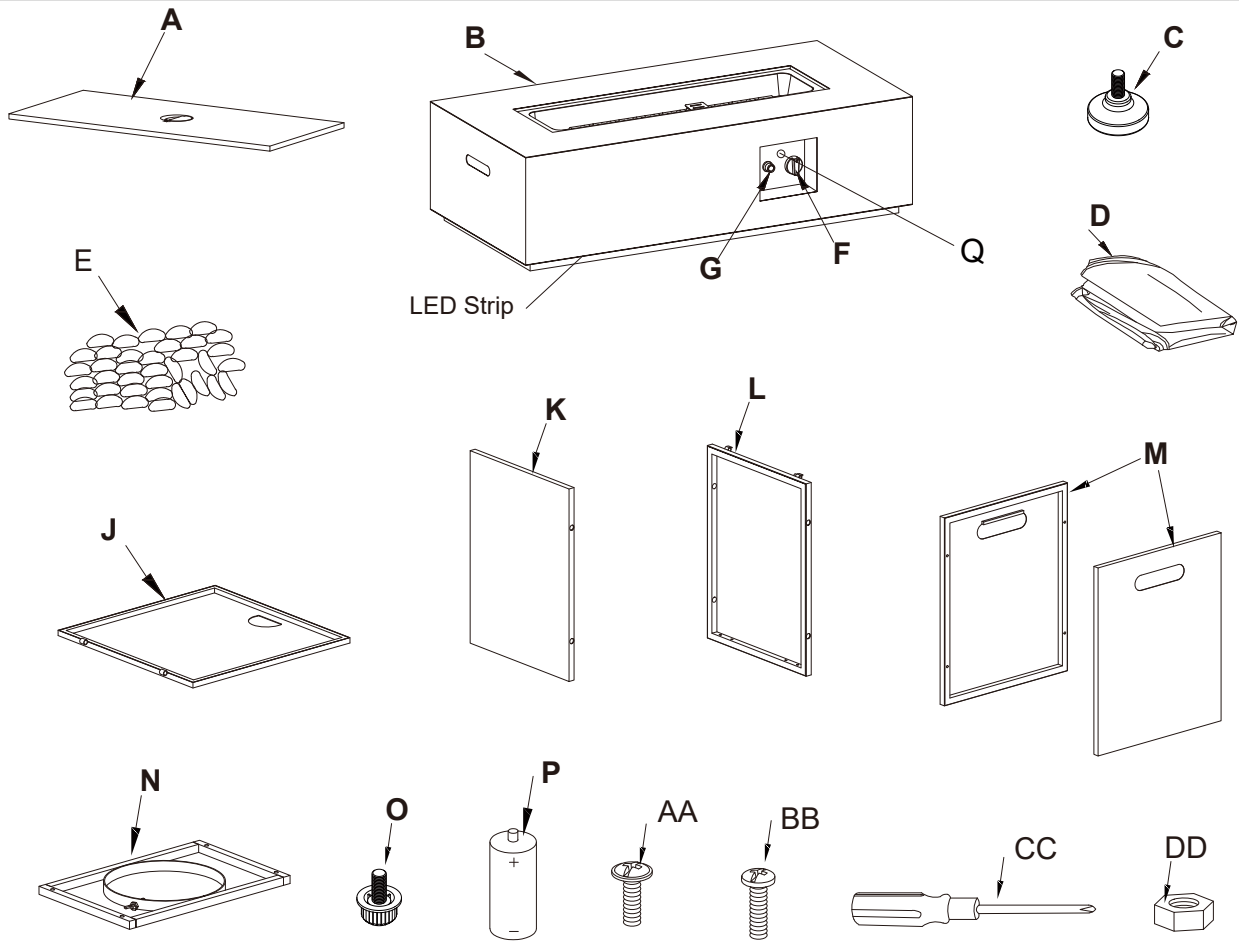

Item	Description	Qty	Item	Description	Qty
A	Table lid	1	N	Metal stand	1
B	Fire pit table	1	O	Feet for tank side table	4
C	Feet for fire pit table	4	P	Battery (AA)	4
D	Protective cover	1	Q	LED Control system (preassembled)	1
E	Glass stone	1 box	AA	M6*25	12
F	Control knob	1	BB	M6*30	1
G	Igniter	1	CC	Screwdriver	1
J	Table panel	1	DD	Nut	1
K	Front panel	1			
L	Back panel	1			
M	Side panel	2			

## SAFETY INFORMATION

This appliance has been tested to and complies with the ANS Z 21.97-2010, Outdoor Decorative Gas Appliances CGA CR 97-003 Outdoor Gas Fireplaces. The installation must conform to local codes or in the absence of local codes to the National Fuel Gas Code, ANS Z223.1. This manual contains important information about the assembly, operation and maintenance of this appliance. General safety information is presented in these first few pages and is also located throughout the manual. Keep this manual for future reference and to educate new users of this product. This manual should be read in conjunction with the labeling on the product. Safety precautions are essential when any mechanical or gas fueled equipment is involved. These precautions are necessary when using, storing, and servicing. Using the equipment with the respect and caution demanded will reduce the possibilities of personal injury or property damage. The following symbols shown below are used extensively throughout this manual. Always heed these precautions, as they are essential when using any mechanical or gas fueled equipment.

## WARNING

Failure to comply with the precautions and instructions provided with this appliance can result in death, serious bodily injury and property loss or damage from hazards of fire, explosion, burn, asphyxiation, and of carbon monoxide poisoning. Only persons who can understand and follow the instructions should use or service this appliance.

## WARNING / DANGER

WARNING/DANGER indicates an imminently hazardous situation which, if not avoided, will result in death or serious injury.

## WARNING

Do not store or use gasoline or other flammable vapors and liquids in the vicinity of this or any other appliance. An LP-cylinder not connected for use shall not be stored in the vicinity of this or any other appliance.

## DANGER

### EXPLOSION—FIRE HAZARD

- Keep solid combustibles, such as building materials, paper, or cardboard a safe distance away from the appliance as recommended by the instructions.
- Provide adequate clearances around air openings into the combustion chamber.
- Never use the appliance in spaces which do or may contain volatile or airborne combustibles, or products such as gasoline, solvents, paint thinner, dust particles, or unknown chemicals.
- During operation, this appliance can be a source of ignition. Keep appliance area clear and free from combustible materials, gasoline, paint thinner, cleaning solvents and other flammable vapors and liquids. Do not use the appliance in areas with high dust content. Minimum appliance clearances from combustible materials: 2 feet (24 inches) from the sides & 2 feet (24 inches) from the rear, 6 feet (72 inches) from ceiling.
- Never store propane near high heat, open flames, pilot lights, direct sunlight, other ignition sources or where temperatures exceed 120 degrees F (49 degrees C).
- Propane vapors are heavier than air and can accumulate in low places. If you smell gas, leave the area immediately.
- Never install or remove a propane cylinder while the appliance is lighted, near flame, pilot lights, or other ignition sources or while the appliance is hot to the touch. This appliance is red hot during use and can ignite flammables too close to the burner. Keep flammables at least 2 feet (24 inches) from top and 2 feet (24 inches) from sides. Keep gasoline and other flammable liquids and vapors well away from the appliance.
- Store the propane cylinder outdoors in a well ventilated space out of the reach of children. Never store the propane cylinder in an enclosed area (house, garage, etc.). If the appliance is to be stored indoors, disconnect the propane cylinder for outdoor storage.

## WARNING

Improper installation, adjustment, alteration, service or maintenance can cause property damage, injury or death. Read the installation, operation and maintenance instructions thoroughly before installing or servicing this equipment.

## DANGER

### FOR YOUR SAFETY

If you smell gas:

1. Shut off gas to the appliance.
2. Extinguish any open flame.
3. If odor continues, keep away from the appliance and immediately call your gas supplier or fire department.

## WARNING

We cannot foresee every use which may be made of our appliance. Check with your local fire safety authority if you have questions about your appliance use. Other standards govern the use of fuel gases and heat producing products for specific uses. Your local authorities can advise you about these. If no local codes exist, follow National Fuel Gas Code, ANS Z223.1. In Canada, installation must conform to local codes. If no local codes exist, follow the current National standards of CANADA CAN/CGA-B 149.2.

## WARNING: FOR OUTDOOR USE ONLY

### CARBON MONOXIDE HAZARD

This appliance is a combustion appliance. All combustion appliances produce carbon monoxide (CO) during the combustion process. This product is designed to produce extremely minute, non-hazardous amounts of CO if used and maintained in accordance with all warnings and instructions. Do not block air flow into or out of the appliance.

- Carbon Monoxide (CO) poisoning produces flu-like symptoms, watery eyes, headaches, dizziness, fatigue and possibly death. You can't see it and you can't smell it. It's an invisible killer. If these symptoms are present during operation of this product get fresh air immediately!
- For outdoor use only.
- Never use inside house, or other unventilated or enclosed area.
- This appliance consumes air (oxygen) Do not use in unventilated or enclosed areas to avoid endangering your life.



## PREPARATION

Before beginning assembly, be sure to empty contents of carton and make sure all parts are present. If any parts are missing, please contact Customer Service at [customer care@jrhome.com](mailto:customer care@jrhome.com) or (800)-561-5550, Monday-Friday, 7:30 a.m. – 4:00 p.m. PST.

Place all parts on a soft, level surface for assembly.

Estimated Assembly Time: 30 Minutes | DO NOT over tighten hardware!

- 1 Attach the 4 pcs adjustable feet (O) to the Back panel (L) and Front panel (K).

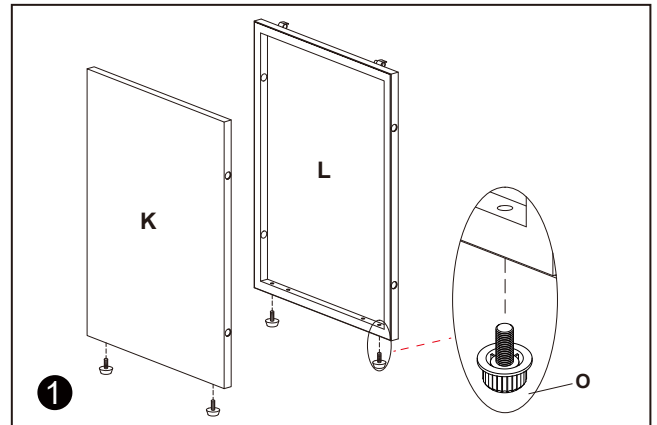

- 2 Attach the metal stand (N) to the Back panel (L) and Front panel (K) using 4 pcs M6\*25 screws (AA).  
Note: Don't tighten screws completely at this step.

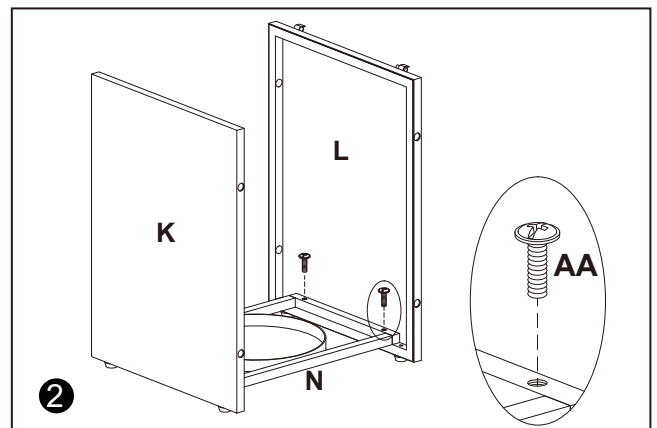

- 3 Attach the side panel (M) to the Back panel (L) and Front panel (K) using 8 pcs M6 \*25 screws (AA).  
Note: Tighten all screws completely.

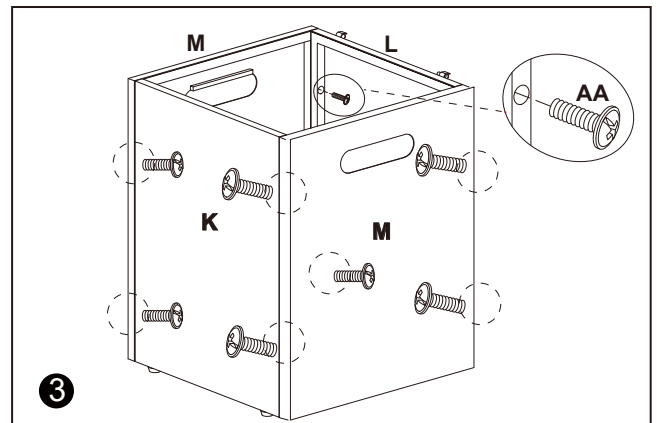

- 4** Attach the top panel (J) to the back panel (L) using 1pc M6\*30 screw (BB) and nut (DD).

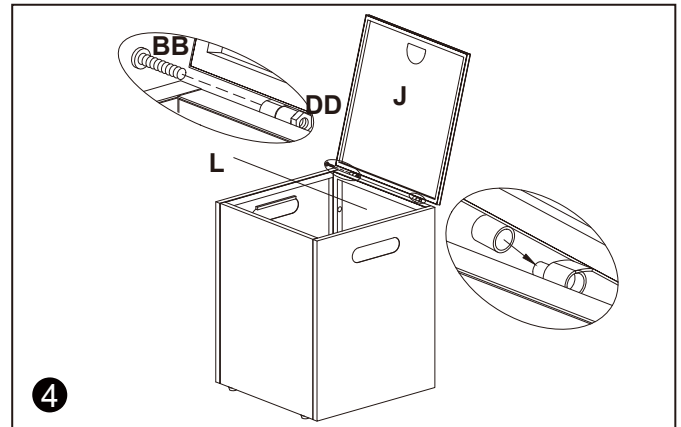

- 5** Place propane gas tank (not included) into the metal stand (N). Make sure the gas tank sits on the metal stand completely. Turn the pre-assembled wing screw on the outer part of metal stand (N) clockwise to secure the propane gas tank tightly.

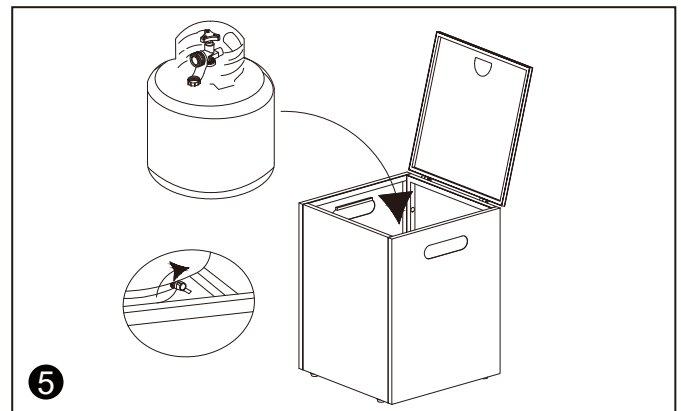

- 6** Check that the control knob (F) for the gas supply system is turned to the "OFF" position before starting any assembly.

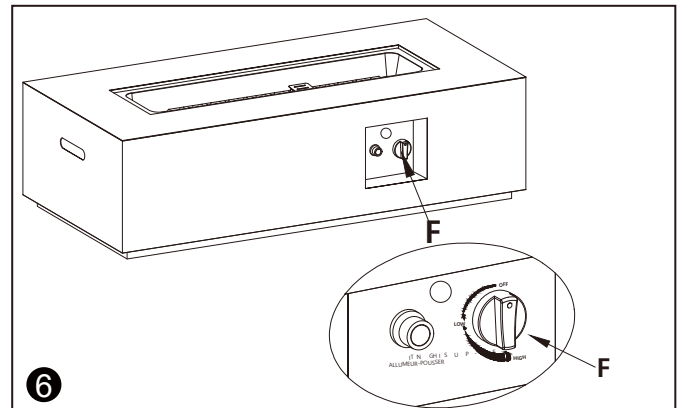

- 7** Attach the 4 pcs adjustable feet (C) to the integrated fire pit table (B).

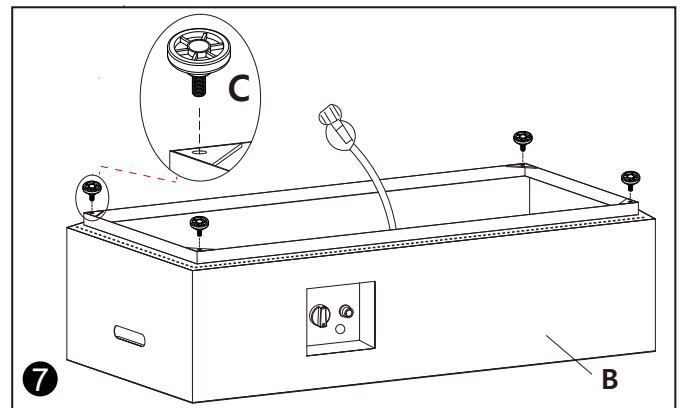

**8** Take out the battery box from box holder, Open battery box, and install 3pcs AA batteries (P) into the battery box, Turn on switch of battery box, Put the battery box back to the holder.

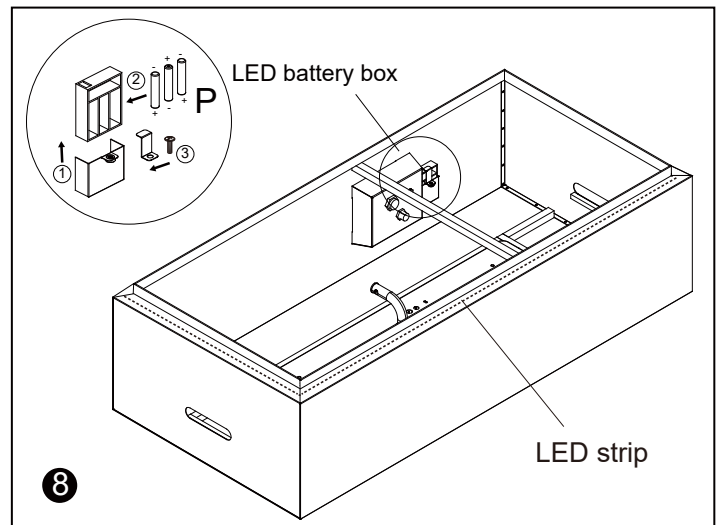

**9** Open the igniter cover and put the AA battery (P) into it, then tighten the igniter cover completely. Pour the Glass stone (E) around the burner. Ensure the lava rock (E) is not placed on the ignition portion of the burner. Place the lid (A) over the fire bowl. The lid must be removed when the burner is in operation. Wait until the unit cools completely before placing the lid.

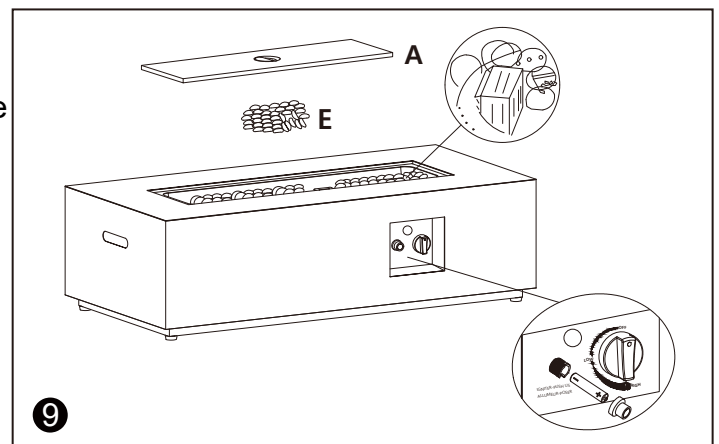

**10** Turn the cylinder valve on the tank clockwise to close the propane tank. Attach the preassembled regulator from the integrated fire pit table (B) to the cylinder valve by turning the regulator coupling nut clockwise. Make sure it is fastened securely and tighten connections by hand only. Finally fix the gas hose to the bracket that is inside the front panel.

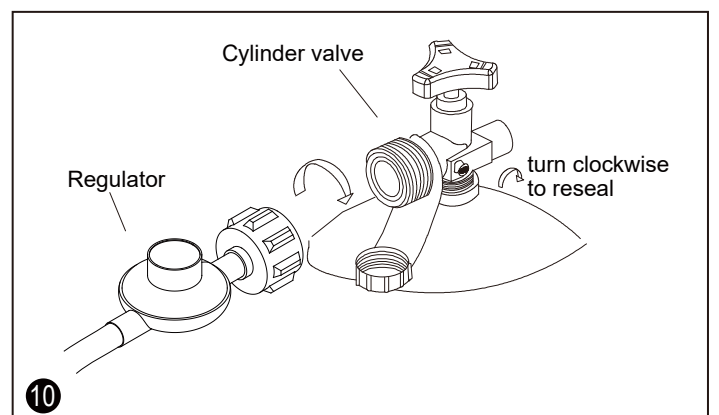

**11** Adjust flame to desired flame with the control knob. To adjust from "OFF" to "LOW", the igniter button needs to be fully pressed then turn the control knob anticlockwise. But switch from "LOW" to "HIGH", loosen igniter button completely and then turn the control knob anticlockwise.

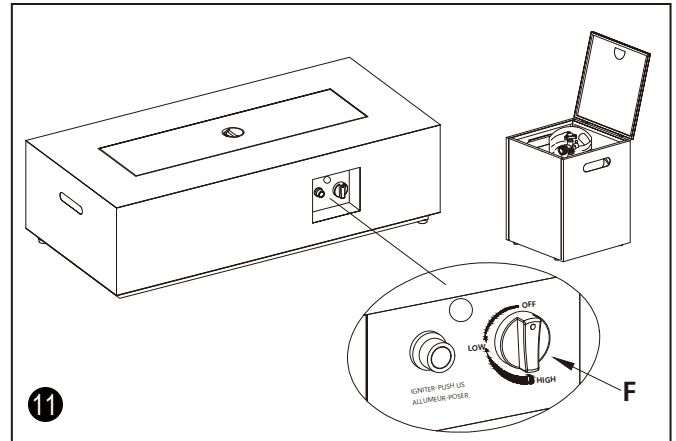

**12** When the gas furnace products are not used outside, should be covered with a protective cover(D), to prevent the product for a long time under the sun and rain caused iron oxidation.

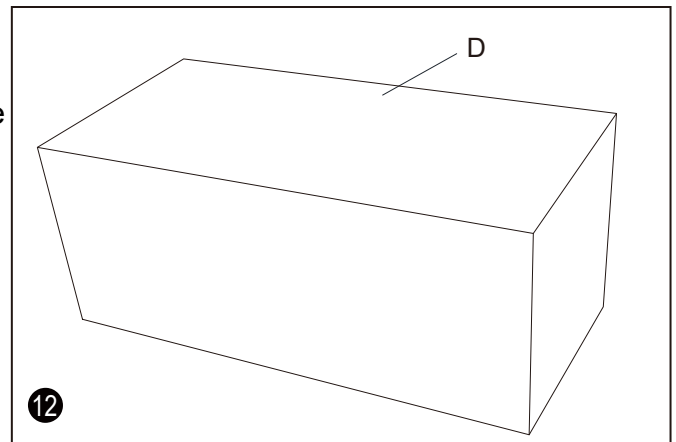



## FOR YOUR SAFETY, READ BEFORE LIGHTING

- Before performing a leak test, make sure that no sparks can occur and you are in a spacious outdoor area.
- Connect the propane gas tank to the regulator and turn the valve on the unit to the “off” position.
- Brush soapy water on all connections.
- Make sure the igniter battery has been installed properly. The igniter will not operate otherwise.
- Before operating, smell around the appliance and next to the ground. If you smell gas or a leak is discovered turn the gas valve off, disconnect propane gas tank and do not use the appliance until the leak is repaired.
- After turning the gas supply, if bubbles occur on any connection there may be a leak.
- Do not use the appliance if any part has been submerged under water. Immediately call a qualified servicetechnician to inspect the unit and to replace the part.
- Do not use the heating unit without inspecting the gas hose (if applicable).
- If there are signs of wear or abrasion, please immediately replace the hose..
- Pumice stones/lava rocks/fire glass could pop up and strike somebody’s face during the process of lighting this unit; stand away from the unit for the first 20 minutes after igniting.

## LIGHTING INSTRUCTIONS

1. Turn the cylinder valve on the gas tank counter-clockwise to open the gas supply.
2. Close the storing door on the fire bowl for the gas tank.
3. Press and hold the Electric Ignitor. Meanwhile, push and turn the Control Knob counter-clockwise to the “LOW” position. Keep pushing the Control Knob to light the burner .
4. After ignition, release the Electric Ignitor. Continue to push and hold the Control Knob for 45 seconds.
5. If ignition does NOT immediately take place in seconds, push and turn the Control Knob clockwise to “OFF”. Wait 5 minutes, then repeat the lighting procedure as above.
6. If the burner does not ignite with the valve open, gas will continue to flow out of the burner and could accidentally ignite with risk of injury.

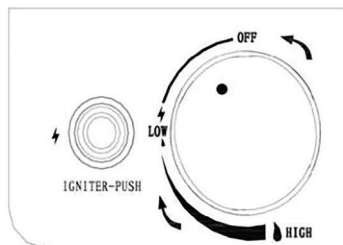

## HOW TO EXTINGUISH ?

1. Push the Control Knob and turn clockwise to the “OFF” position.
2. Turn the cylinder valve on the gas tank clockwise to close the gas supply if not in use for a long time (See figure below).

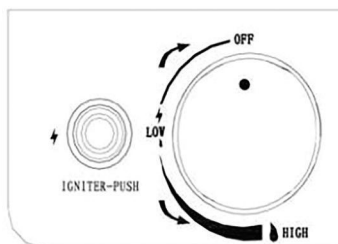

To enjoy years of outstanding performance from your fire pit, make sure you perform the following maintenance activities on a regular basis:

1. Use warm soapy water for cleaning. Never use flammable or corrosive cleaning agents.
2. While cleaning your unit, be sure to keep the area around the burner and control compartment dry at all times. Do not submerge the control valve assembly. If the gas control is submerged in water, do NOT use it. It must be replaced. Make sure fire pit has cooled completely before cleaning or covering with a cover.
  - A. Keep the appliance area clear and free from combustible materials, gasoline and other flammable vapors and liquids.
  - B. Do not obstruct the flow of combustion and ventilation air.
  - C. Keep the ventilation opening(s) of the cylinder enclosure free and clear from debris.
3. Air flow must be unobstructed. Keep controls, burner, and circulating air passageways clean. Signs of possible blockage include:
  - Gas odor with extreme yellow tipping of flame.
  - Fire pit does NOT reach the desired temperature.
  - Fire pit glow is excessively uneven.
  - Fire pit makes popping noise.
  - Spiders and insects can nest in burner or orifices. This dangerous condition can damage fire pit and render it unsafe for use. Clean burner holes by using a heavy-duty pipe cleaner. Compressed air may help clear away smaller particles.
  - Carbon deposits may create a fire hazard. Clean burner screen with warm soapy water if any carbon deposits develop.



*Note: In a salt-air environment (such as near an ocean), corrosion occurs more quickly than normal. Frequently check for corroded areas and repair them promptly.*

## SERVICE:

Only a qualified service person should repair gas passages and associated components.

••••• *Always allow fire pit to cool before attempting service.*

## WARNING

### FOR YOUR SAFETY

- Do NOT touch or move fire pit for at least 45 minutes after use.
- Burner is hot to the touch.
- Allow burner to cool before touching.

## STORAGE:

### Between uses:

- Turn control knob OFF.
- Disconnect LP source.
- Store fire pit in an area sheltered from direct contact with inclement weather (such as rain, sleet, hail, snow, dust and debris).
- If desired, cover fire pit to protect exterior surfaces and to help prevent build-up in air passages.

### During periods of extended inactivity or when transporting:

- Turn control knob OFF.
- Disconnect LP source and move to a secure, well-ventilated location outdoors.
- Store fire pit in an area sheltered from direct contact with inclement weather (such as rain, sleet, hail, snow dust and debris).
- If desired, cover fire pit to protect exterior surfaces and to help prevent build-up in air passages. Never leave LP cylinder exposed to direct sunlight or excessive heat.

**Note:** Wait until fire pit is cool before covering.

# TROUBLE SHOOTING



PROBLEM	CAUSE	SOLUTION
Burner will not light using igniter	Electrode and burners are wet	Wipe dry with cloth.
	Igniter battery is dead or backwards	Check that the AA battery is inserted correctly in the igniter or replace the battery. Make sure the plastic wrap on the battery has been removed.
	Igniter Pin cracked or broken - sparks a crack	Please contact us to request the parts
	Residue on Igniter Pin	Check for residue on the igniter pin or Thermocouple. If dirty, thoroughly clean the area. Check that the electronic Igniter Cap is tightly fitted to the spring. If loose, please adjust the spring accordingly.
Burner will not light with match	No Gas Flow	Check if the LP gas tank is empty. If empty, replace and refill. If the propane tank is not empty, refer to Problem: Sudden drop in gas flow on the following page.
	Coupling nut and regulator not fully connected	Turn the coupling nut about one half to three fourths a turn, until you feel a solid stop. Do not use tools, tighten by hand only.
	Obstruction of gas flow	Check for bent or kinked hose.
	Spider webs or insect nest in the venturi	Clean the venturi.
	Burner ports clogged or blocked	Reference Problem: Irregular flame pattern on the following page. Clean the burner ports as described there.
The fire table emits a lot of black smoke when in use	Hose from gas fire table is pinched	Make sure the hose is not pinched between the fire table and the source of the gas.
	Flame is being obstructed at burner ports or mixing chamber of the burn tube is blocked or obstructed	Make sure that the gas ports on the burner are free of any lava rocks/fire glass so that the flame can flow naturally. Clear out the mixing chamber located before the Venturi.
Sudden drop in gas flow, or a reduced flame height	Out of Gas.	Check for gas in the LP gas tank.
	Excess flow safety device may have been activated	Turn control knob to OFF, wait 30 seconds and light outdoor fire table. If flames are still too low, reset the excessive flow safety device by turning off the control knob and LP gas tank valve. Disconnect regulator. Turn burner control knob to HIGH. Wait at least 5 minutes. Turn burner control knob off. Reconnect regulator and perform a leak check at tank connection. Turn LP gas tank valve on slowly, wait 30 seconds and then light outdoor fire table.
Irregular flame pattern, flame does not run the full length of the burner	Burner ports are clogged or blocked	Clean burner ports. Do this by inserting a paperclip into each of the burner ports to ensure they are not clogged. <b>WARNING:</b> Make sure burner is not on, and has had sufficient time to cool before touching it.
Flame blow out	High or gusting winds	Increase flame to HIGH setting
	Low on LP gas	Replace or refill LP gas tank.
	Excess flow valve tripped	Refer to Problem: Sudden drop in gas flow.
Flame seems to lose heat when burning in cold weather - temperature below 50°F	Ice has built up on the outside of the LP gas tank because the vaporization process is too low	Turn the control knob and the LP gas tank to OFF. Replace with a spare LP gas tank and resume burning. Store the spare LP gas tank in a well ventilated area, away from children.

**Problem:** Burner lights momentarily and then turns off.

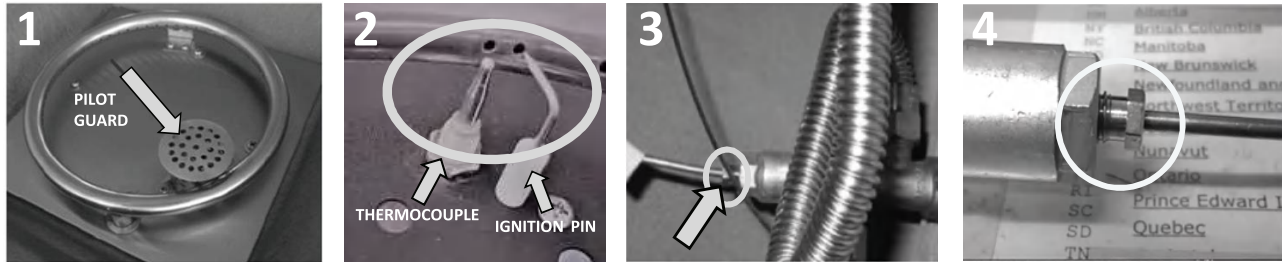

1. The thermocouple will be under the Pilot Guard on the top of the unit. Please remove the Pilot guard by unscrewing it from the metal bowl with a screw driver.
2. Once the Pilot Guard has been removed, you will have two components exposed; the copper one is your thermocouple. Please unscrew the nut holding the thermocouple in place.
3. Inside the unit, you will notice that the end of the thermocouple line is directly screwed to the gas valve. Please unscrew the thermocouple from the back end of the gas valve. Do not take off the valve's silver backing, only unscrew the small nut as shown above.
4. Screw the end of the thermocouple to the back end of the gas valve with the silver backing.

Once this has been done, please test the unit. You may have to reset the gas valve once again as the safety mechanism may have been set off by the new components introduced:

## RESETTING YOUR GAS VALVE

Insure propane is off and then unscrew the propane tank from the regulator.  
Turn the heat knob to high and leave it on that setting for about two to three minutes and then turn back to off.  
Reconnect the regulator to the propane tank. Very slowly turn the propane tank valve until fully open.

**NOTE:** When reattaching the propane tank, please turn the valve to release the gas back in to the unit **VERY SLOWLY**. We want the unit to register gas coming through but not too much at once, this will flood the unit and you will have to start all over!

This is so that the gas valve can register the gas coming through a little at a time. Once you have turned the gas on all the way please go ahead and try to light the table again. This should reset your fire table's safety mechanism.

This product has been manufactured under the highest standards of quality and workmanship.

We warrant to the original consumer that all aspects of this product will be free of defects in material and workmanship for one year from the date of purchase. A replacement for any defective part will be supplied free of charge for installation by the consumer. Defects or damage caused by the use of other than genuine parts are not covered under this warranty.

**This warranty shall be effective from the date of purchase as shown in the purchase receipt.**

**The manufacturer warranty will be voided by, and manufacturer disclaims any responsibility for, the following actions but not limited:**

- Modification of the unit and/or components including the gas valve assembly.
- Use of any component part not manufactured or approved by JR Home.
- Use and installation other than what is listed in this manual.

## ***Extend Your Warranty By Leaving A Review***

We want your opinion about your purchase...and we want you to tell everyone about it!

Just leave a review for the product on the retailers website where you made your purchase, or at [www.jrhome.com](http://www.jrhome.com), and fill in the online warranty at [www.jrhome.com/warranty-registration](http://www.jrhome.com/warranty-registration) within 30 days of purchase to receive a complimentary extra year of warranty protection.

*Follow us on:  
Suivez-nous sur*



**YouTube**



***[www.jrhome.com](http://www.jrhome.com)   #jrhome   #activeflame***

# IMPORTANT

For questions, concerns or problems with our product please email our customer service department:

**customercare@jrhome.com**

DATED PROOF OF PURCHASE REQUIRED FOR WARRANTY SERVICE

Si vous éprouvez des difficultés ou si vous avez des questions ou des préoccupations, prière de faire parvenir un courriel à notre service à la clientèle

**customercare@jrhome.com**

UNE PREUVE D'ACHAT DATÉE EST REQUISE POUR SE PRÉVALOIR DE LA GARANTIE.

## WARRANTY

This product is inspected, tested and carefully packaged to minimize the chance of damage during shipment. If a part (excluding light bulbs, glass and fuses\*) within one year from the date of purchase proves to be defective in material or fabrication under normal use, the part will be repaired or replaced. The Company's obligation under the warranty is to replace or repair defective parts at our discretion. Any expenses or damage resulting from the installation, removal or transportation of the product will be the responsibility of the owner and are not covered by this warranty. The owner assumes all other risks arising from the use or misuse of the product. The warranty will be void if the product damage or failure is deemed by the Company to be caused by accident, alteration, misuse, abuse, incorrect installation or removal, or connection to an incorrect power source by the owner. The Company neither assumes, nor authorizes any person or entity to assume for it any obligation or liability associated with its products. Light bulbs and fuses are not covered under this warranty. If you have any questions regarding the warranty or service, please contact us at **customercare@jrhome.com**.

Customer Service :

JR Home Products

Unit 306 - 19100 Airport Way, Pitt Meadows, BC V3Y 0E2

Toll Free : 1-800-561-5550

E-mail : **customercare@jrhome.com**

## AVERTISSEMENT

Ce produit a été soigneusement inspecté, testé et emballé afin de minimiser les risques de dommages durant le transport. Si l'une des pièces (à l'exception des verres, des ampoules électriques et des fusibles\*) s'avère défectueuse au niveau de sa fabrication ou de ses matériaux dans l'année qui suit la date de l'achat suite à une utilisation normale, la pièce sera réparée ou remplacée. La compagnie est tenue de réparer ou remplacer les pièces défectueuses à sa discrétion, en vertu de la garantie. Tous frais ou dommage résultant de l'installation, du démantèlement ou du transport du produit demeurent la responsabilité du client et n'est pas couvert par cette garantie. Le client assume tout autre risque résultant de l'utilisation correcte ou fautive du produit. La garantie devient nulle si la compagnie détermine que le dommage ou le mauvais fonctionnement est causé par un accident, une modification, une mauvaise utilisation, un abus, une mauvaise installation ou un mauvais démantèlement ou un branchement à une source électrique inadéquate de la part du client. La compagnie n'est pas responsable et n'autorise quiconque, personne ou entité légale, à accepter de responsabilité ou obligation en son nom, en rapport avec ses produits. \* Les ampoules électriques et les fusibles ne sont pas couverts par cette garantie. Pour toute question au sujet de la garantie ou du service, contacter le service à la clientèle à : **customercare@jrhome.com**.

Service à la clientèle:

JR Home Products

Unit 306 - 19100 Airport Way, Pitt Meadows BC V3Y 0E2

Numéro sans frais: 1-800-561-5550

Courriel: **customercare@jrhome.com**

**You MUST register your product within 30 days of purchase to receive warranty service.**

**Registration can be completed online at [www.jrhome.com](http://www.jrhome.com) or by mailing this form.**

**Vous DEVEZ enregistrer votre produit dans les 30 jours suivant l'achat pour bénéficier du service de garantie.**

**L'enregistrement sera complet une fois que vous aurez posté ce formulaire ou que vous serez inscrit en ligne.**

## Warranty Registration Information Form / Formulaire d'enregistrement de la garantie

Name / Nom : \_\_\_\_\_

Street / Adresse : \_\_\_\_\_

City / Ville : \_\_\_\_\_

Province / Province : \_\_\_\_\_

Postal Code / Code postal : \_\_\_\_\_

Daytime Phone # / No téléphone jour : \_\_\_\_\_

Evening Phone # / No téléphone soir : \_\_\_\_\_

E-Mail Address / Courriel : \_\_\_\_\_

Product/Produit : \_\_\_\_\_

Place of Purchase / Lieu de l'achat : \_\_\_\_\_

Date of Purchase / Date de l'achat : \_\_\_\_\_

Model # / No de modèle : \_\_\_\_\_

Serial # / Numéro de série : \_\_\_\_\_

You MUST register your product to receive warranty service.

For warranty service, contact J&R Home Products at the address, phone numbers listed below within 30 days of purchase. Be sure to have your sales receipt and original date of purchase. All warranty service will be coordinated by J&R Home Products service center.

Vous DEVEZ enregistrer votre produit pour vous prévaloir de la garantie.

Afin de faire valoir la garantie, communiquez avec J&R Home Products à l'adresse et aux numéros indiqués ci-dessous dans les 30 jours suivant la date d'achat. Ayez en main votre reçu et la date d'achat. Toutes les demandes liées aux garanties seront traitées par le centre de service de J&R Home Products.

