

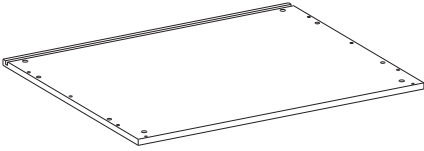

A

× 1



B

× 1

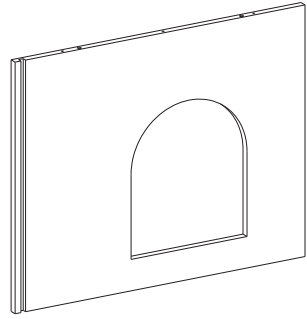

C

× 1

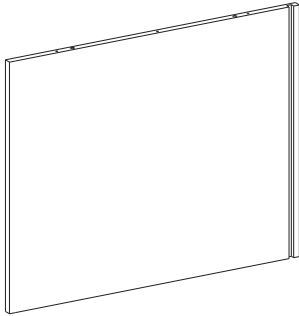

D

× 1

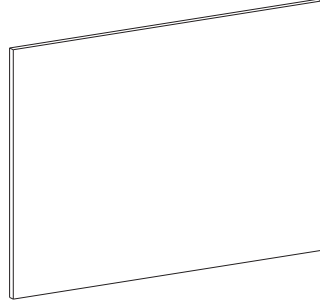

E

× 1

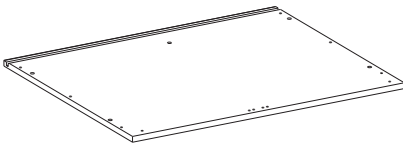

F

× 1

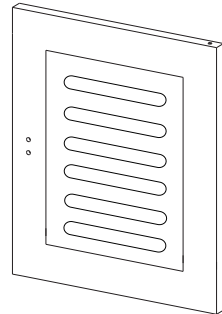

G

× 1

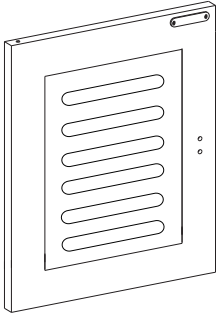

H

× 1

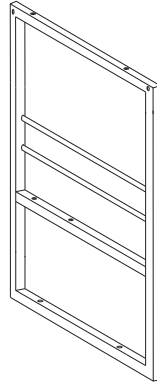

I

× 1

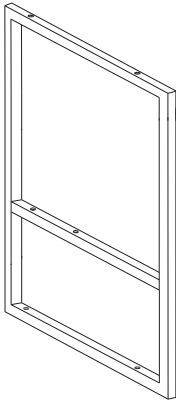

J

× 2

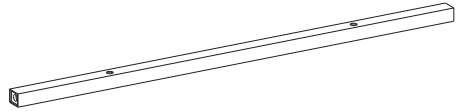

K

× 1

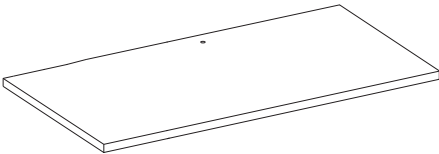

L

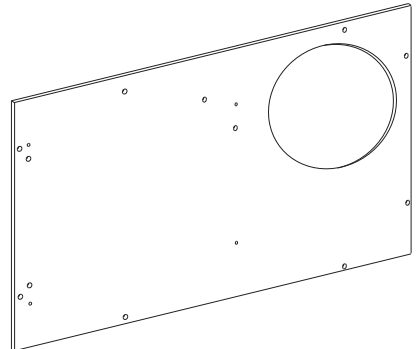

M

× 1

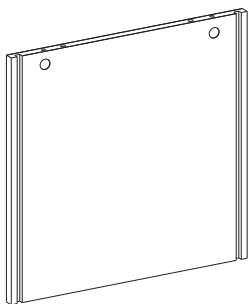
**N**

× 1

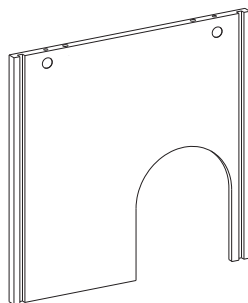
**O**

× 1

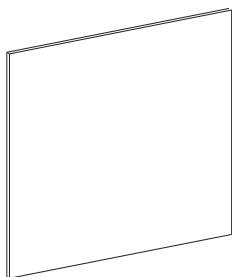
**P**

× 1

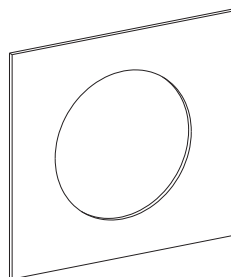

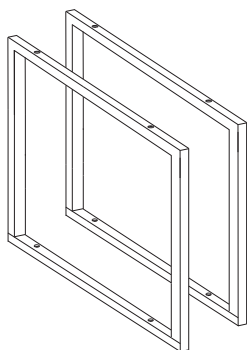

**Q**

× 1

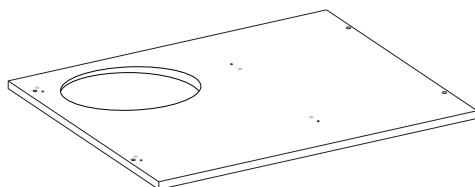
**R**

× 1

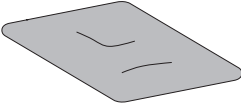
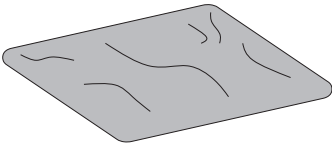

<p>S1 × 1</p>  <p style="text-align: center;">Φ71×400mm</p>	<p>S2 × 1</p>  <p style="text-align: center;">71×260mm</p>
<p>T × 4</p> 	<p>U × 1</p> 
<p>V × 1</p> 	<p>W × 1</p> 

X

× 1

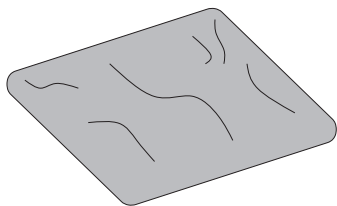

Y

× 1

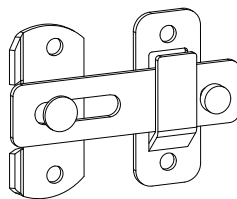

Z1

× 2

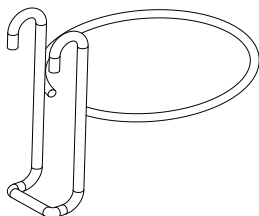

Z2

× 2

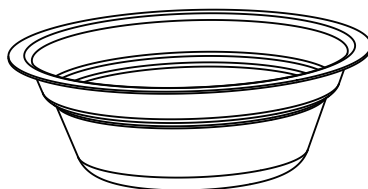

Z3

× 2

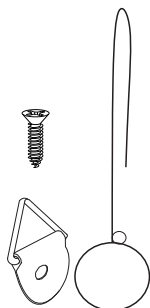

Hardware

Y1



× 4

Y2



× 4

Y3



× 15

Y4



× 4

W1

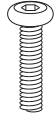

× 22

M6 × 30 mm

W2

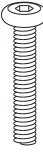

× 4

M6 × 40 mm

W3

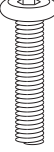

× 2

M8 × 40 mm

W6

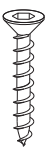

× 16

M4 × 40 mm

W7



× 8

M4 × 15 mm

W8

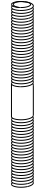

× 1

M8 × 80 mm

K3

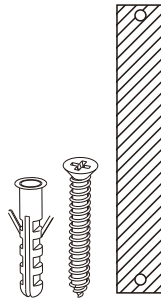

× 2

K4



× 1

K5

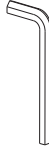

× 1

K6

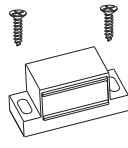

× 2

K7



× 2

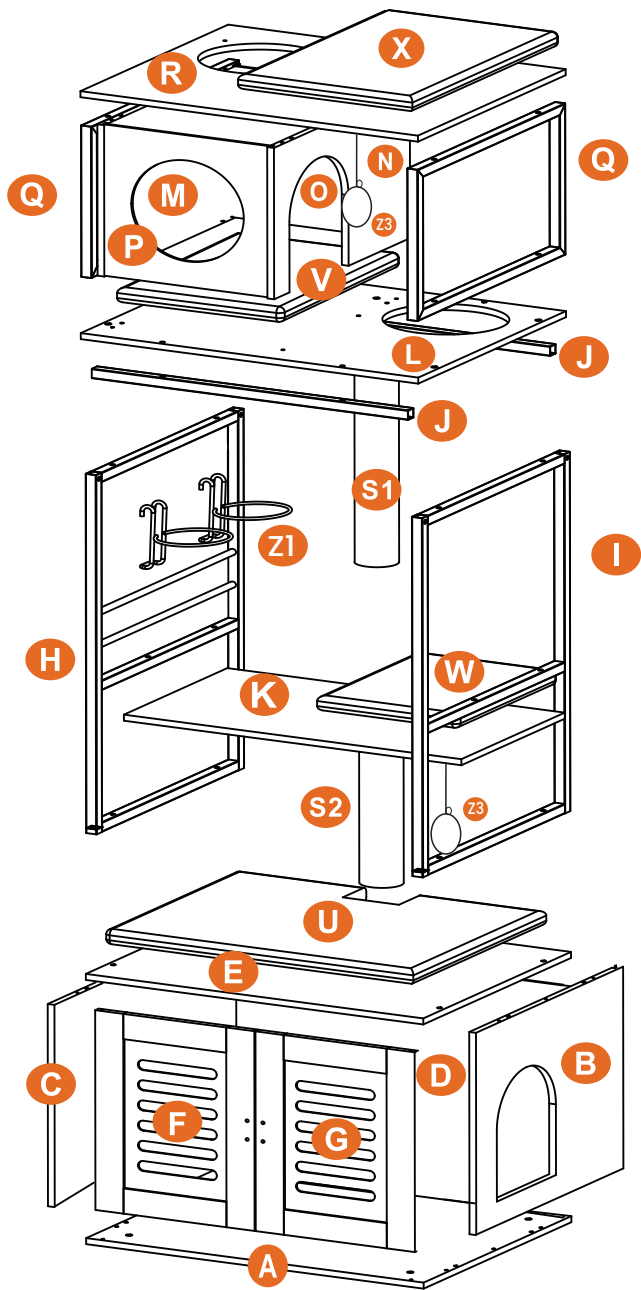

1

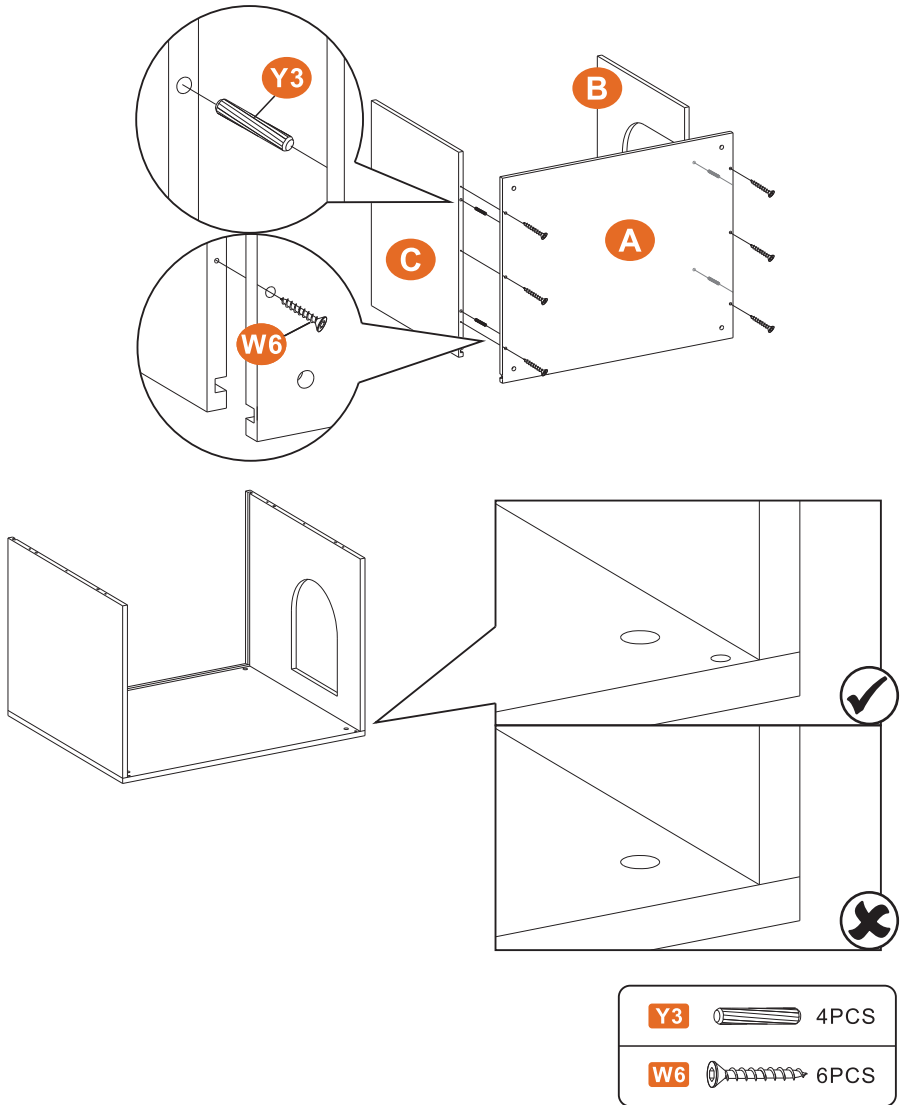

2

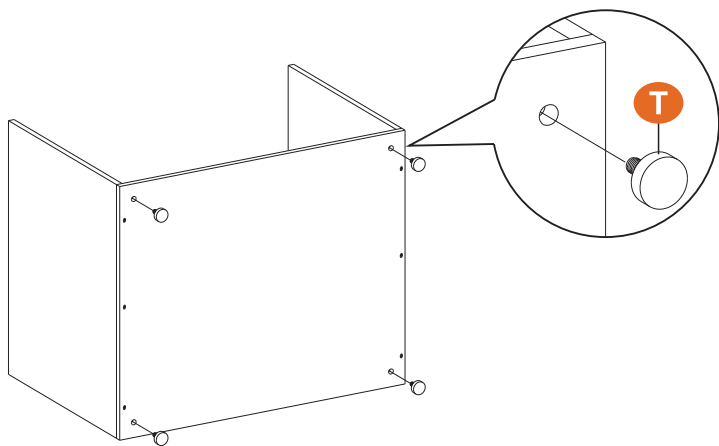

T



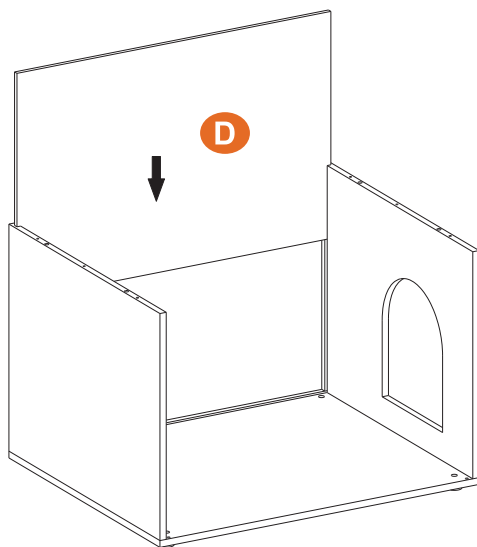

4PCS

3

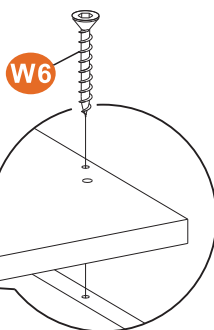
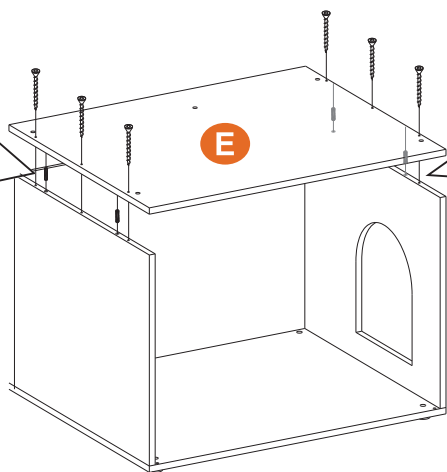
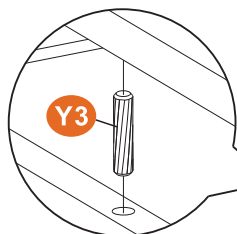
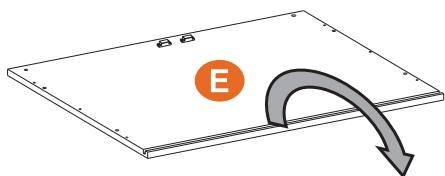
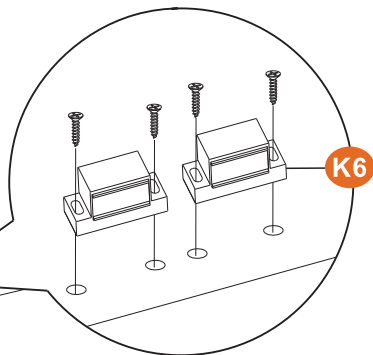
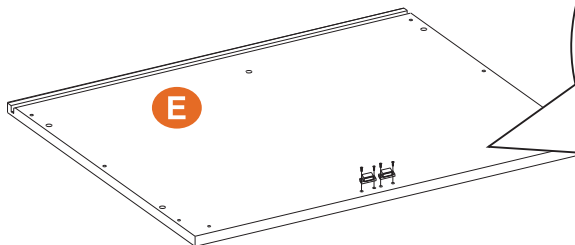

4



Y3		4PCS
W6		6PCS

5

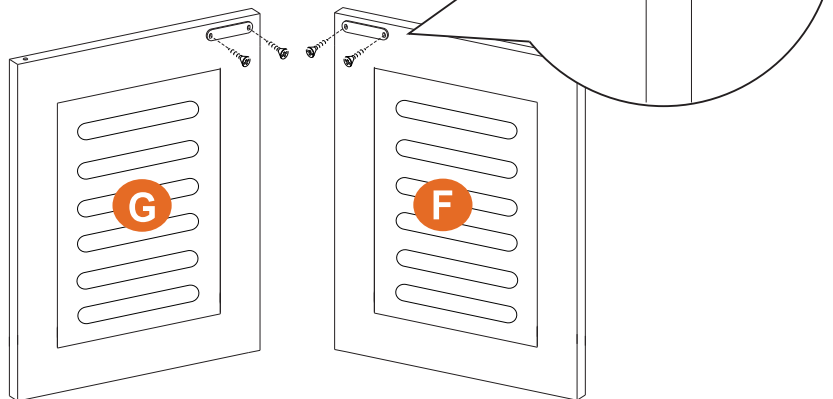

W7  4PCS

6

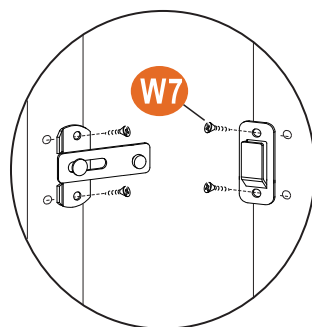
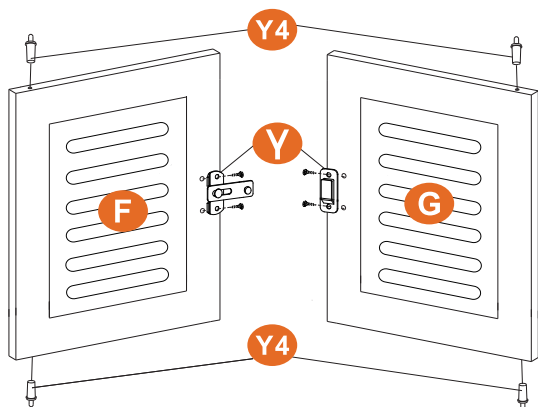

Y4  4PCS

W7  4PCS

7

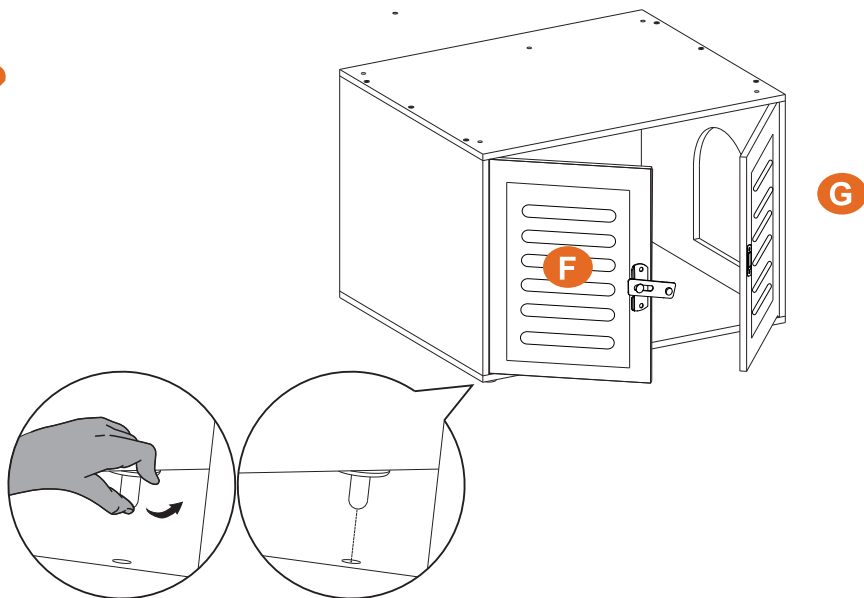

8

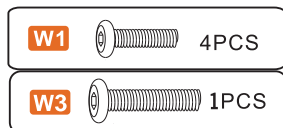
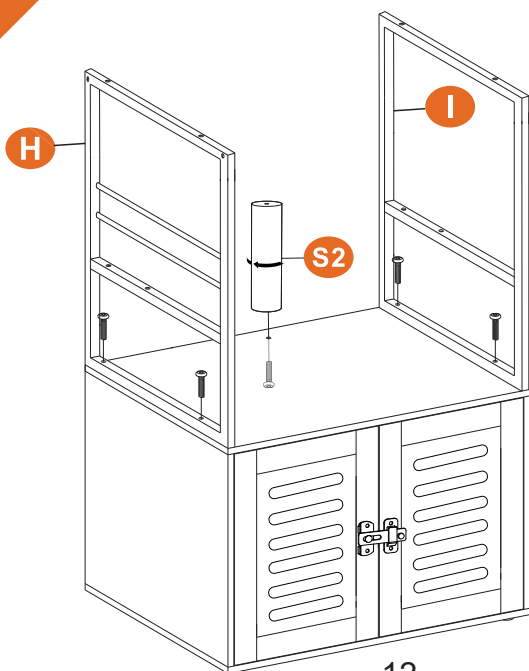

9

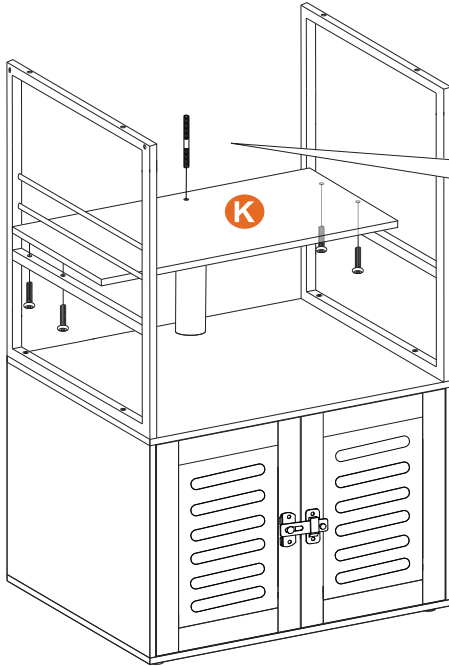

W1 4PCS

W8 1PCS

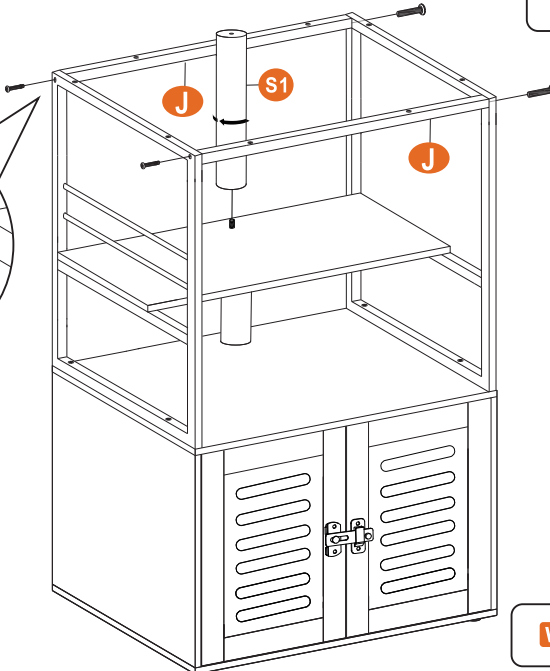

10

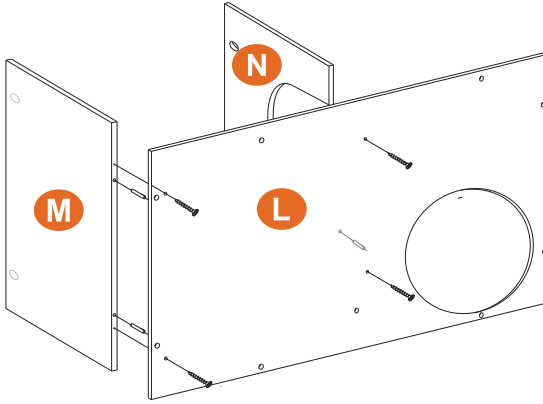

W1 4PCS

11



W6		4PCS
Y3		3PCS

12

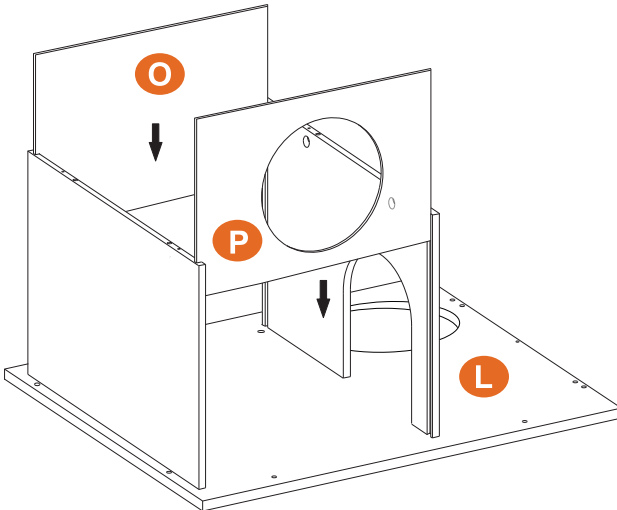

13

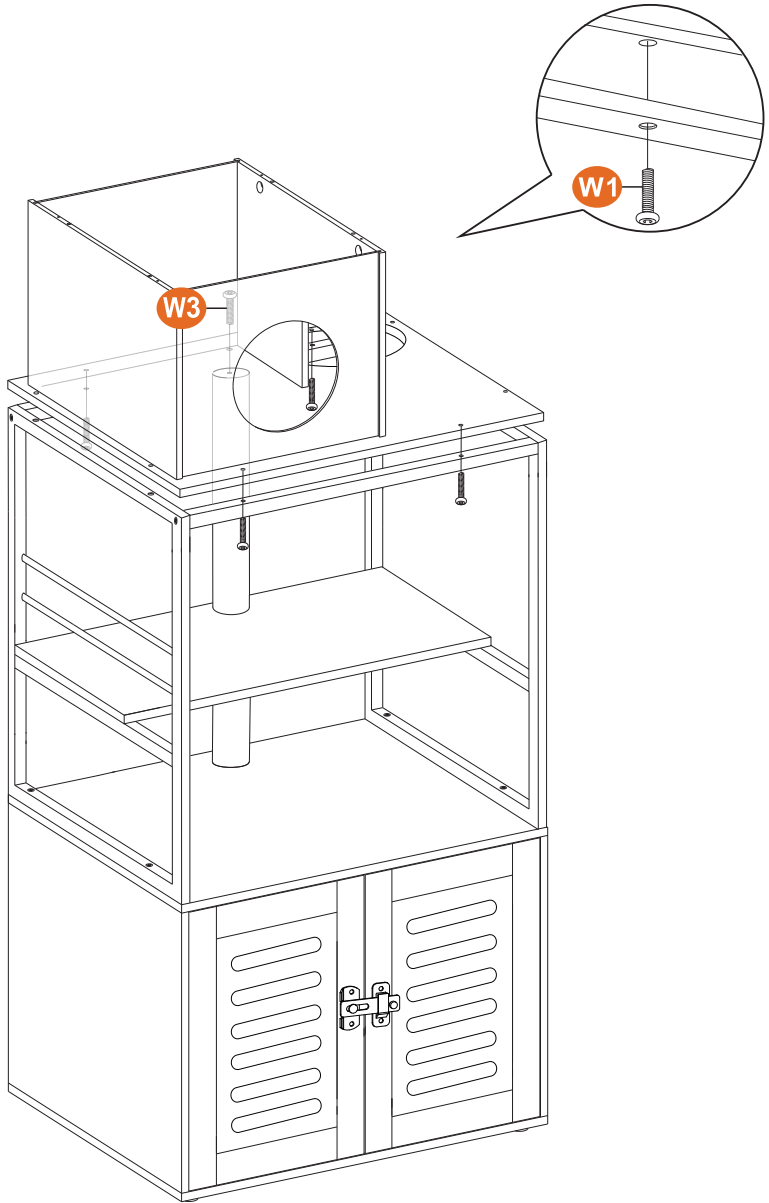

W1  4PCS

W3  1PCS

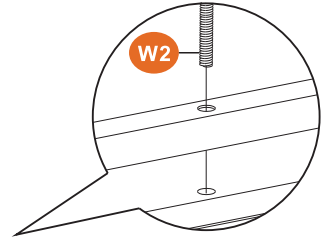
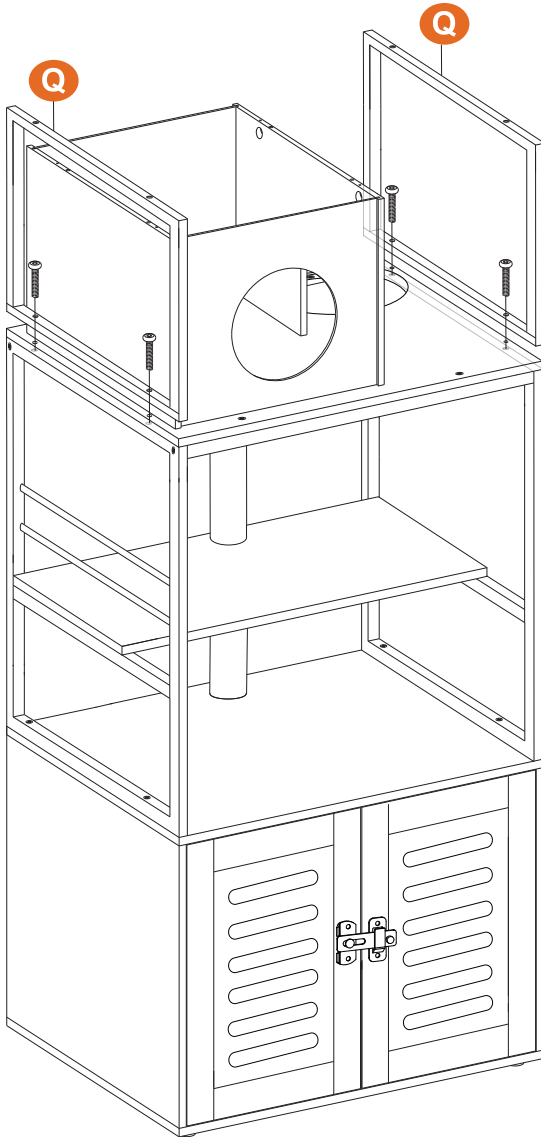

14

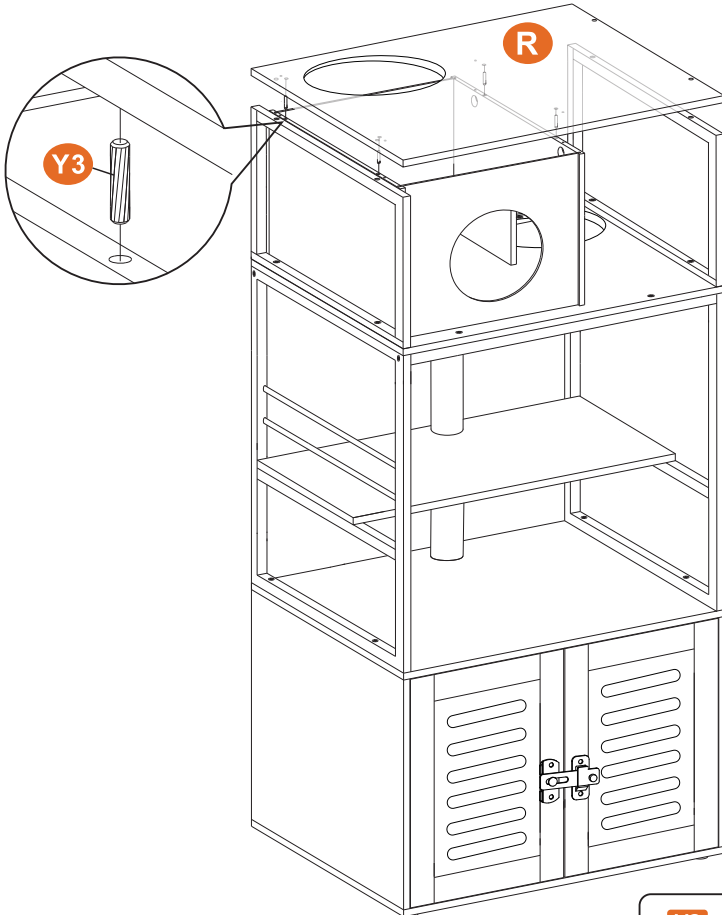
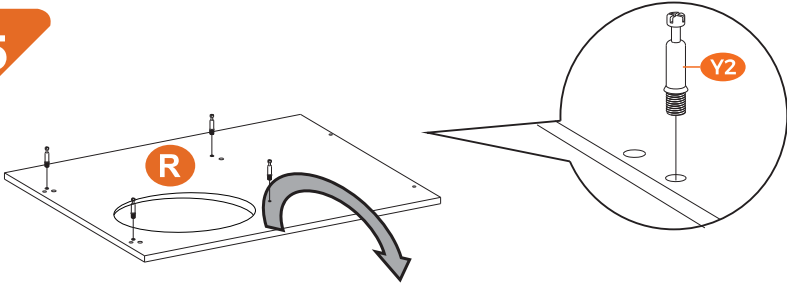

W2  4PCS

15



Y2		4PCS
Y3		4PCS

16

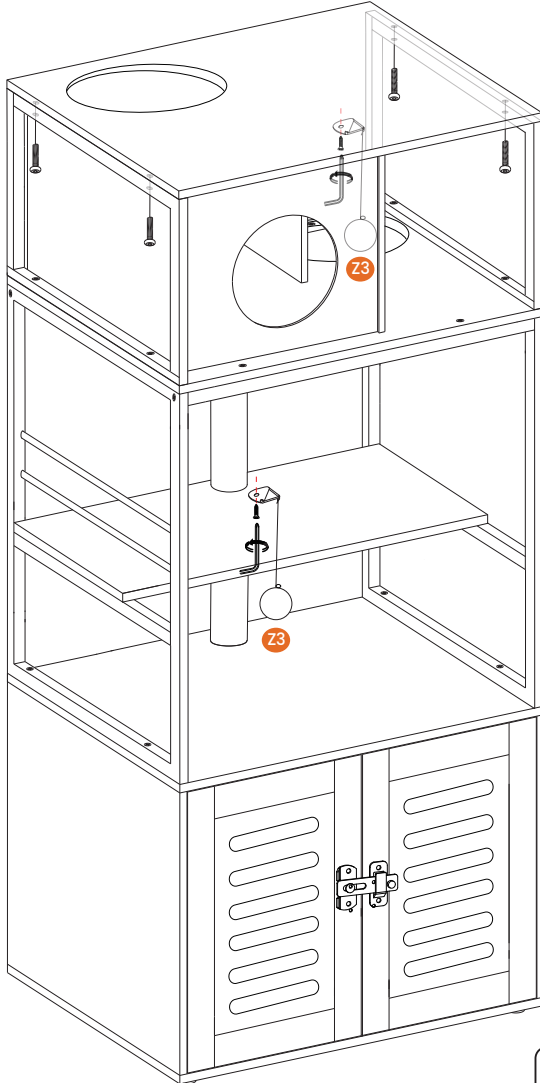
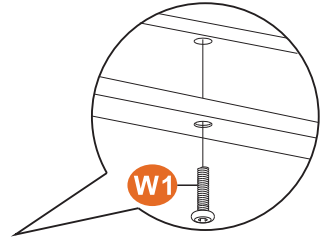

W1  4PCS

17

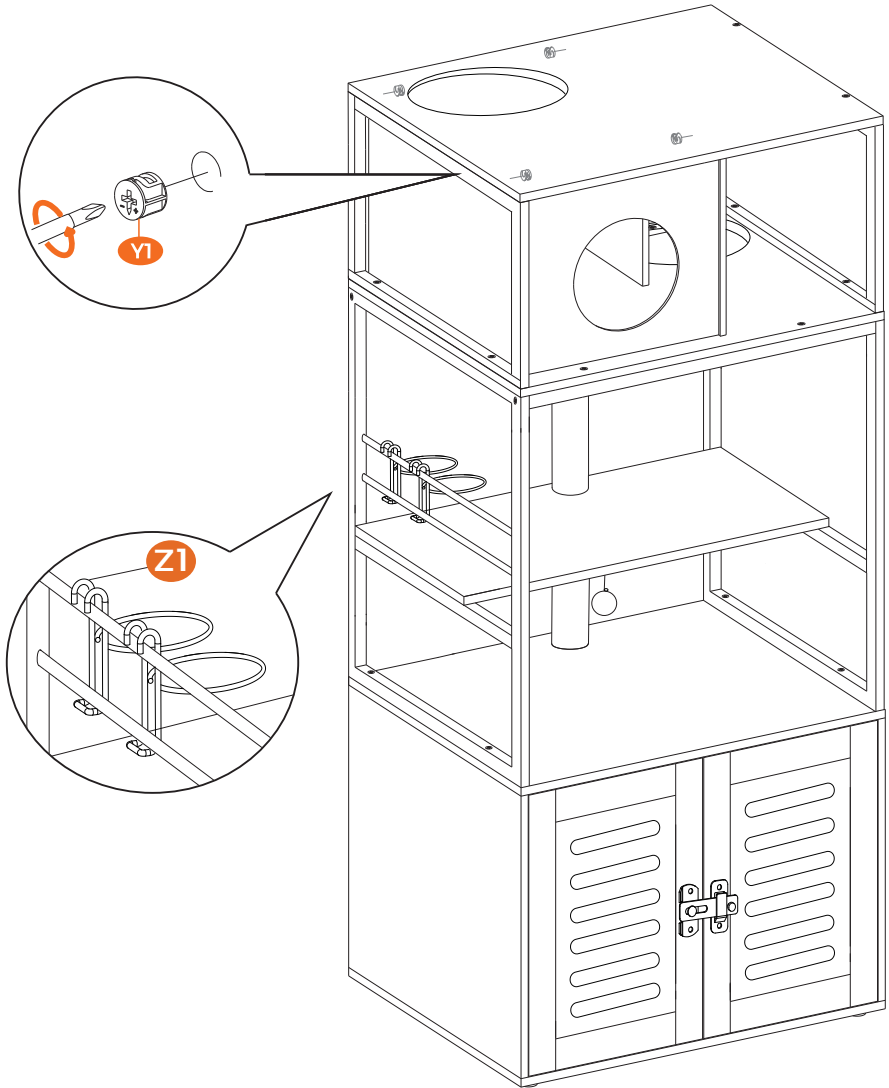

18

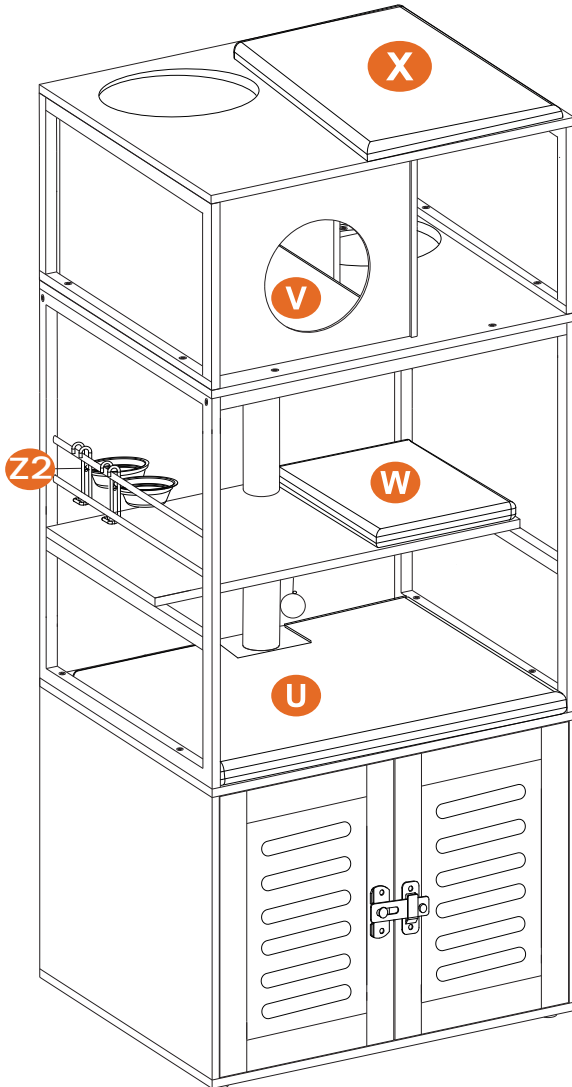

19

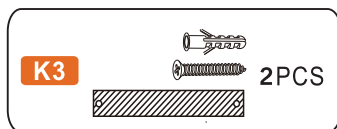
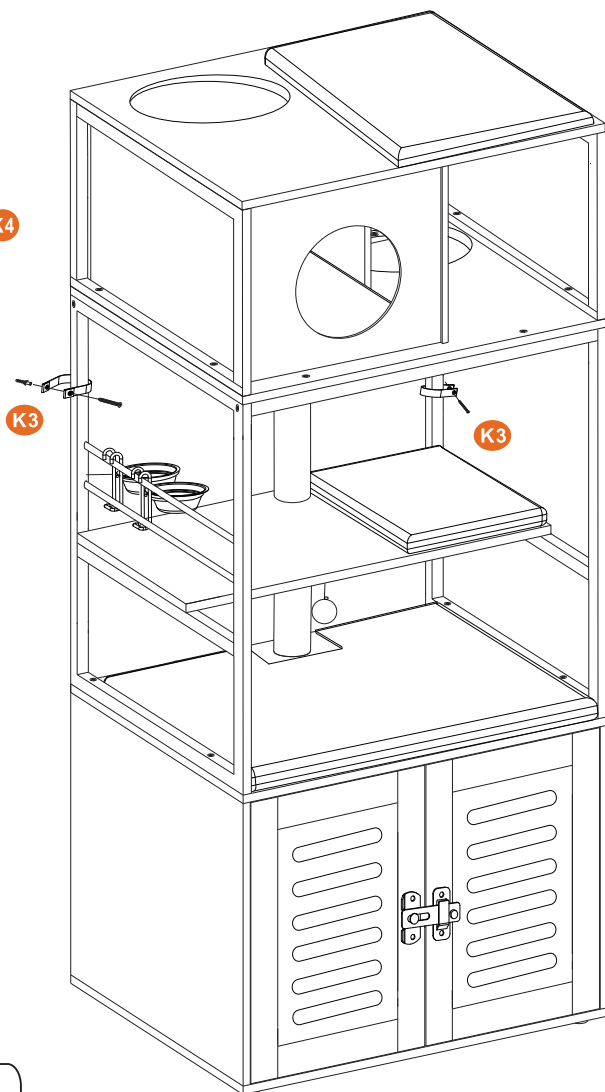
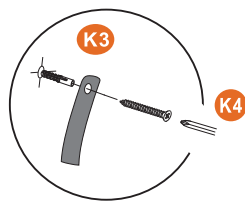

-
- EN** • Even the box it comes in can be made to a cat box with a pair of scissors and some tape in just a few simple steps (scissors and tape are not included).
- DE** • Der Verpackungskarton lässt sich mit Hilfe von Schere und Klebeband in ein paar Schritten in einen Katzenkarton umwandeln.
- FR** • Vous pouvez transformer la boîte de transport en niche pour chat en carton en quelques étapes simples avec une paire de ciseaux et du ruban adhésif (non inclus).

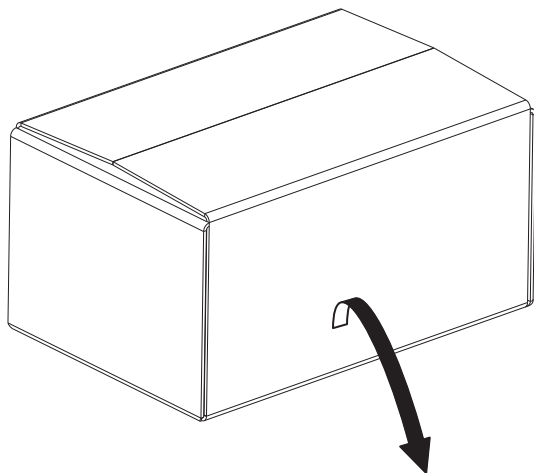

- IT** • Puoi trasformare la scatola d'imballaggio in una casetta per il tuo gatto in pochi minuti, bastano delle forbici e nastro adesivo.

- ES** • Utilizando una tijera y una cinta adhesiva mediante varios pasos sencillos, la caja de embalaje puede convertirse en una caja para gatos (la tijera y la cinta adhesiva excluidas).

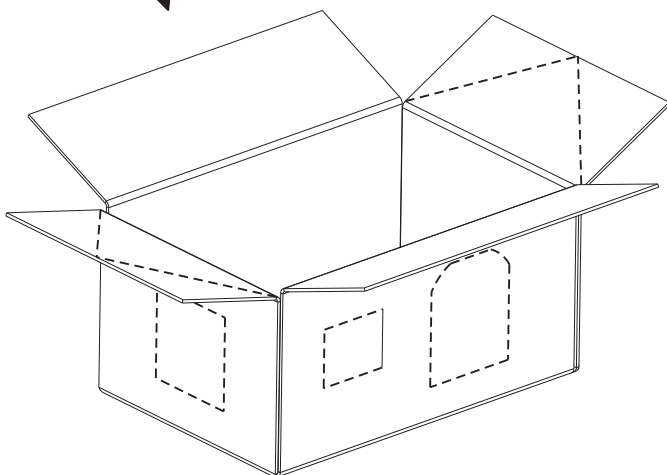

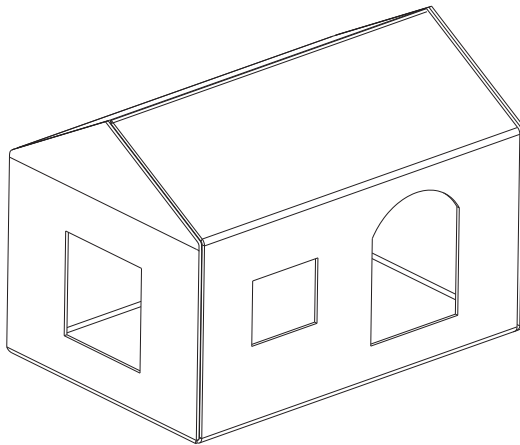
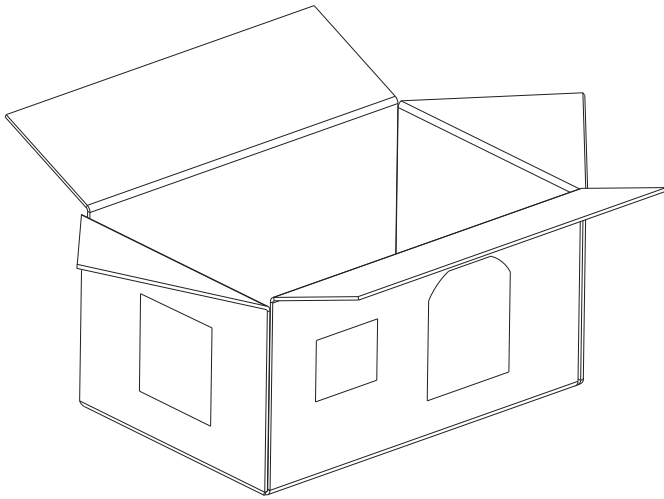

Tel: 1-844-628-2348

E-mail: service@kalrin.com

Website: www.kalrin.com