

Assembly Instructions

Caution: You must read this before you proceed

Care & Maintenance



- Not for commercial use. For residential use only.



- Furniture may scratch floors. We recommend using furniture pads to protect your floors.



- Do not put hot items directly on furniture surface.



- Do not clean furniture with harsh cleansers or polish.



- Do not place furniture under direct sunlight.



- Do not place furniture near heating or cooling vents.



- Do not write on furniture without a padded barrier to protect the surface.



- Do not place furniture outside . For indoor use only.



- Stains may be removed with mild soap solution and damp cloth.



- Children should not climb or jump on the furniture.



- Dust and pick-up spills using a clean, non-colored, lint-free cloth.

KING BED



WARNING !

STRANGGULATION HAZARD

NEVER place bed near windows where cords from blinds or drapes may strangle a child.

NEVER suspend strings over bed.

NEVER place items with a string, cord, or ribbon, such as hood strings or pacifier cords, around a child's neck. These items may catch on bed parts.

ALWAYS follow assembly instructions.

Not intended for children under the age of six. **INFANTS HAVE DIED FROM BECOMING ENTRAPPED IN BEDS.** Openings in and between bed parts can entrap the neck and head of a small child.

NEVER use bed for child under the age of six.

The mattress must be appropriately sized for the bed. If the mattress is undersized, dangerous gaps can exist and a person can become entrapped or entangled in the frame and suffocate.

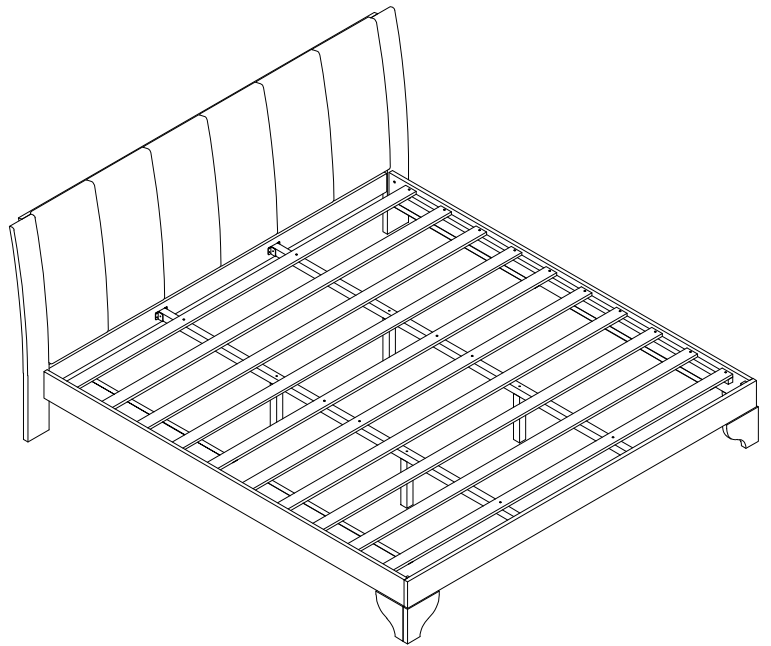





CAUTION: This King Bed is NOT a TOY.

Keep your child / children at bay in the process of assembly.



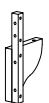

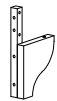
For turning the King Bed and to prevent damage to the King Bed.

02 persons may be needed to execute this action.

PART LIST (Hardware in this SKU)

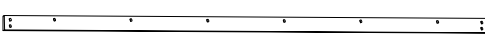
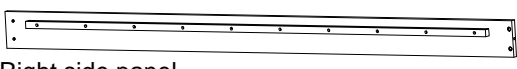
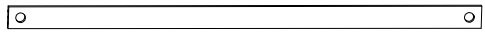
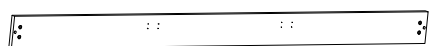
K		6pcs	N		1pc
	Upholstered Headboard			left hip	
L		1pc	O		1pc
	left front leg			right hip	
M		1pc			
	right front leg				

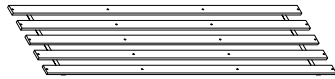
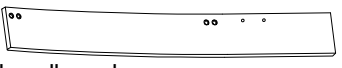
PART LIST

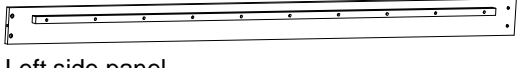
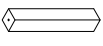
A		2pcs	F		1pc
	Top rail			Right side panel	
B		1pc	G		1pc
	Headboard crossbar			Bed footboard	
C		1pc	H		2pcs
	Leg-left headboard			Slats	
D		1pc	I		2pcs
	Leg-right headboard			Center rail	
E		1pc	J		4pcs
	Left side panel			Center support leg	

Hardware (Each of the above hardware including extra 1 pc)

Label	Picture	Description	Q.ty
①		Vis Ø 4 x 30mm	28+1
②		Vis Ø 4 x 15mm	24+1
③		Threaded Rod Ø5/16"x70mm)	2+1
④		Bolt Ø1/4" x 75mm	4+1
⑤		Bolt Ø1/4" x 40mm	12+1
⑥		Bolt Ø1/4" x 35mm	20+1
⑦		Screws Ø6.3x80mm	4+1
⑧		Allen wrench	1
⑨		Wooden dowel Ø10 x 30 mm	12+1
⑩		Metal link (66x35x27mm)	4
⑪		Leveler Ø1/4 x 25 mm	4
⑫		Hex nut (M8x6mm)	2+1
⑬		Half moon washer (27x4x7mm)	2+1
⑭		Open wrench (90x12mm)	1
⑮		Screwdriver (Not provided)	1

Assembly Preparation

Overview

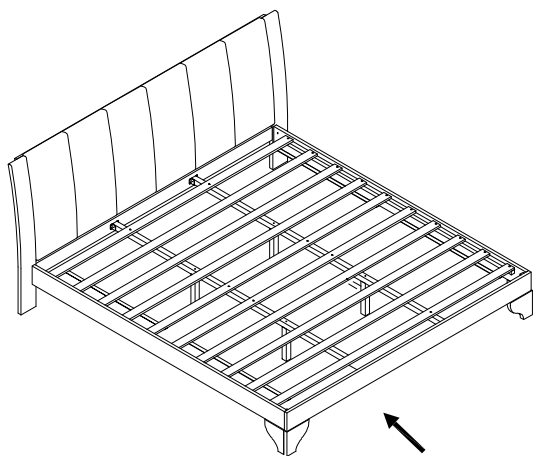

FRONT FACING

This King Bed has multiple parts and may require up to 1 hour to assemble. To give you an overview of the King Bed parts, the above picture is to help you put the various parts into perspective. Please read through the instructions herebelow to familiarise the parts and steps before assembly.

Assembly Preparation

Before Beginning Assembly

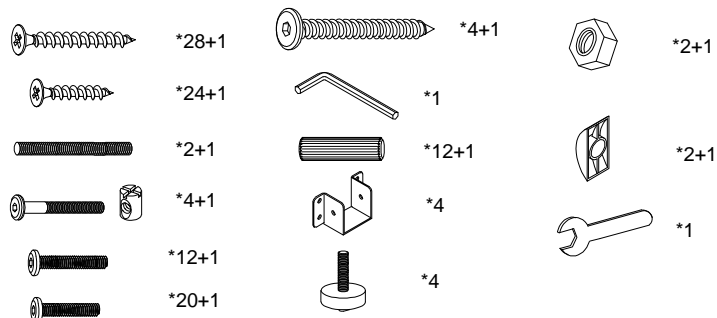
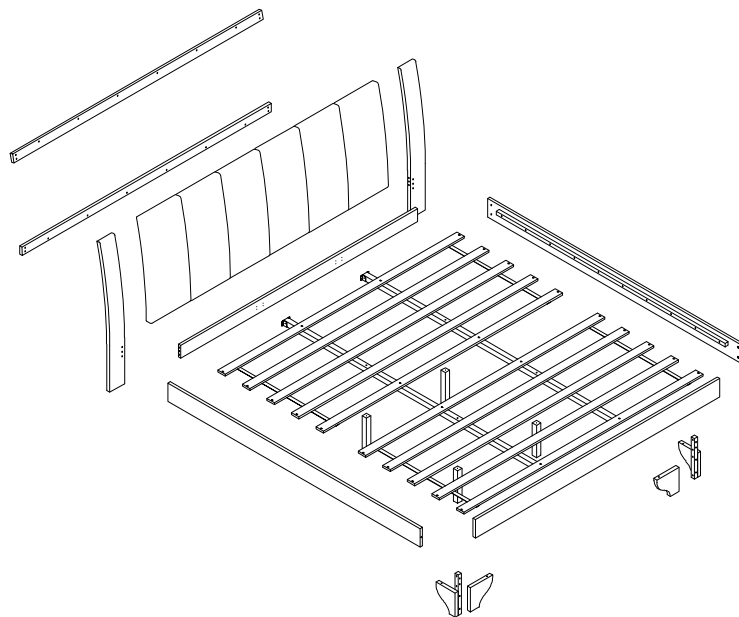

- Read instruction, cover to cover.
- Have 2 adults on hand for assembly.
- Do not assemble on flooring or carpet.
- Assemble on a clean non-marring surface (packing foam).
- Save all packaging until finished.

Step 1:

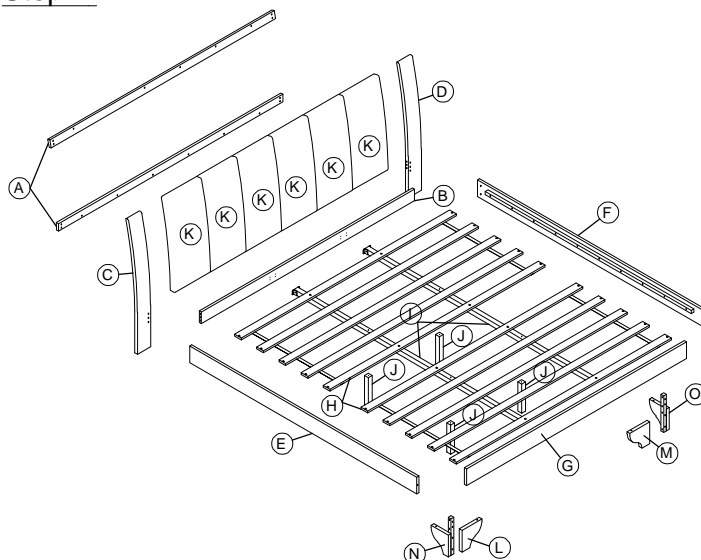

Unpack and place all part on a clean, non-marring surface.

Step 2:

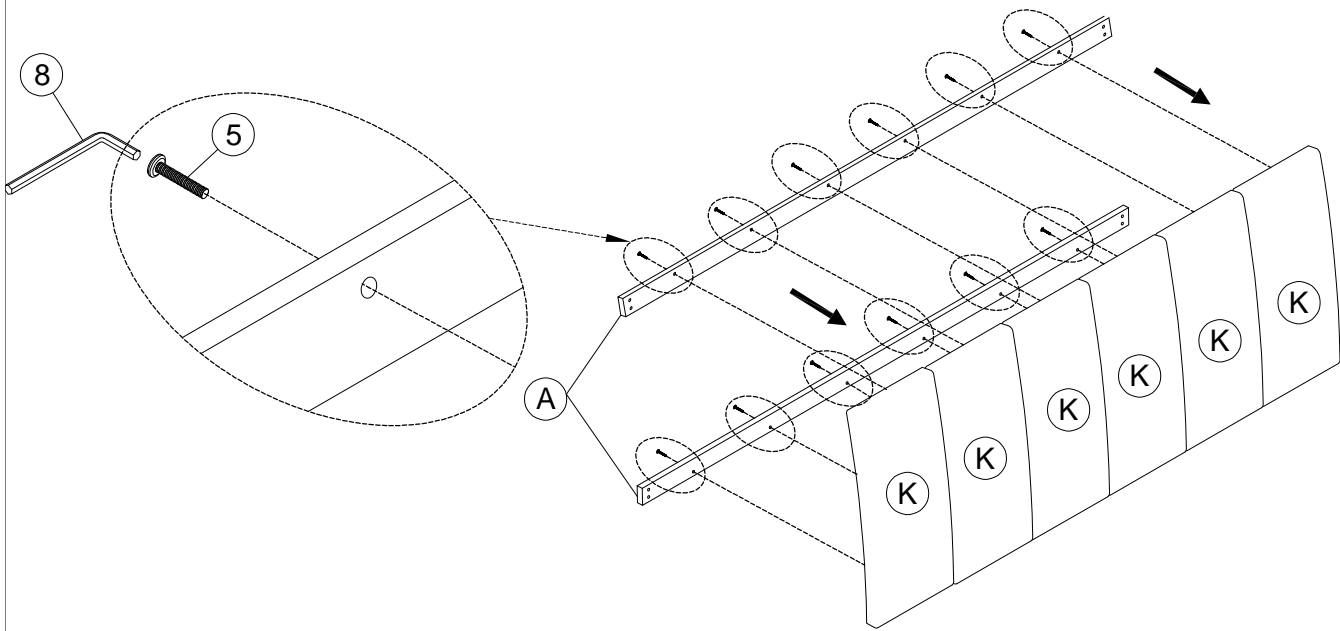

-Attach Top rail (A) to Upholstered Headboard (K) using Bolt 5 and Allen wrench 8 as shown in the image.
Do not fully tighten the Bolts.

Step 3:

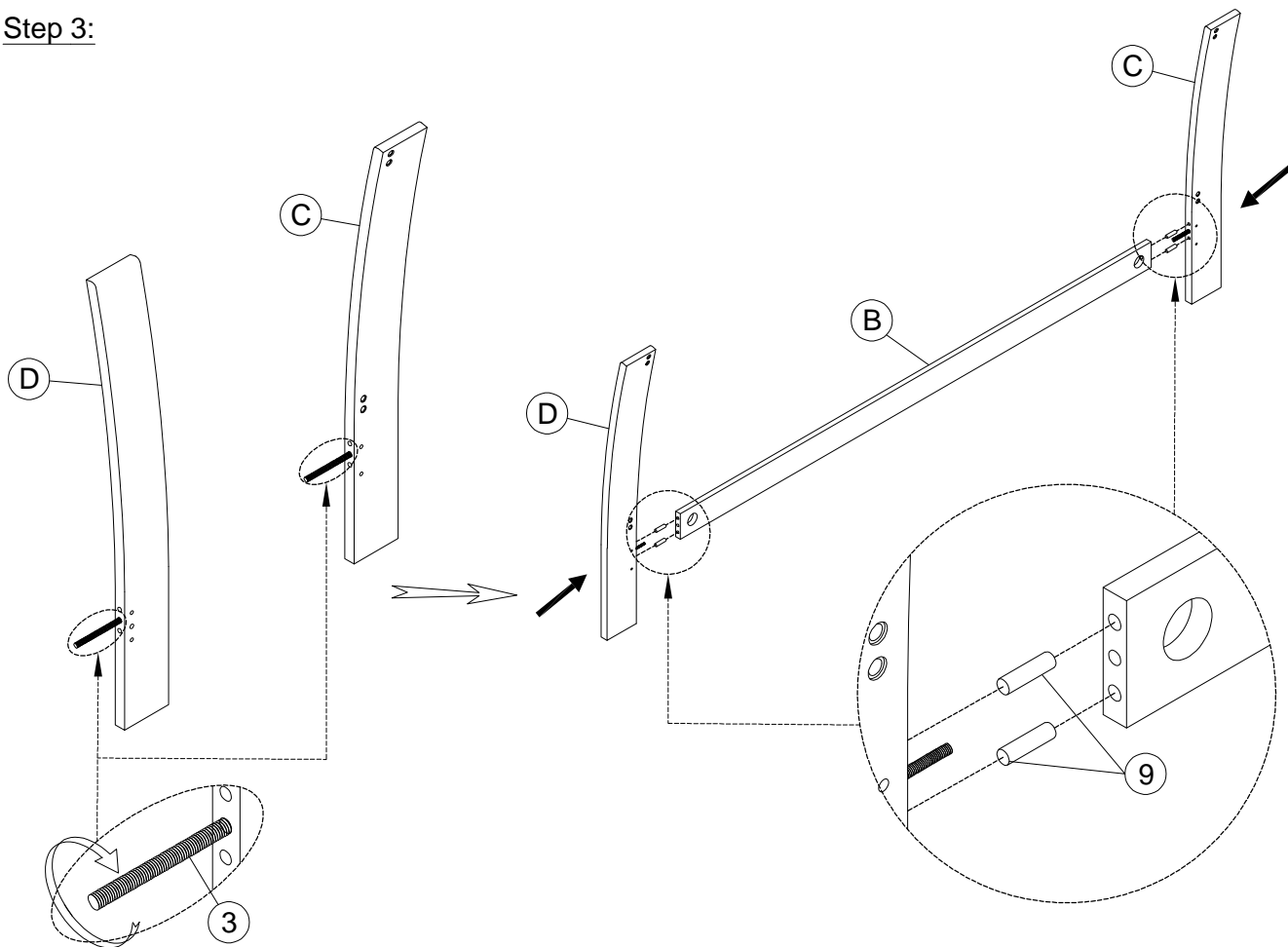

3.1: Attach the Threaded Rod 3 to the Leg-left headboard (C) and Leg-right headboard (D) as shown in the illustration.

3.2: Attach the Leg-left headboard (C) and Leg-right headboard (D) to the Headboard crossbar (B) using Wooden dowels 9 as shown in the image.

Do not fully tighten the Bolts.

Step 4:

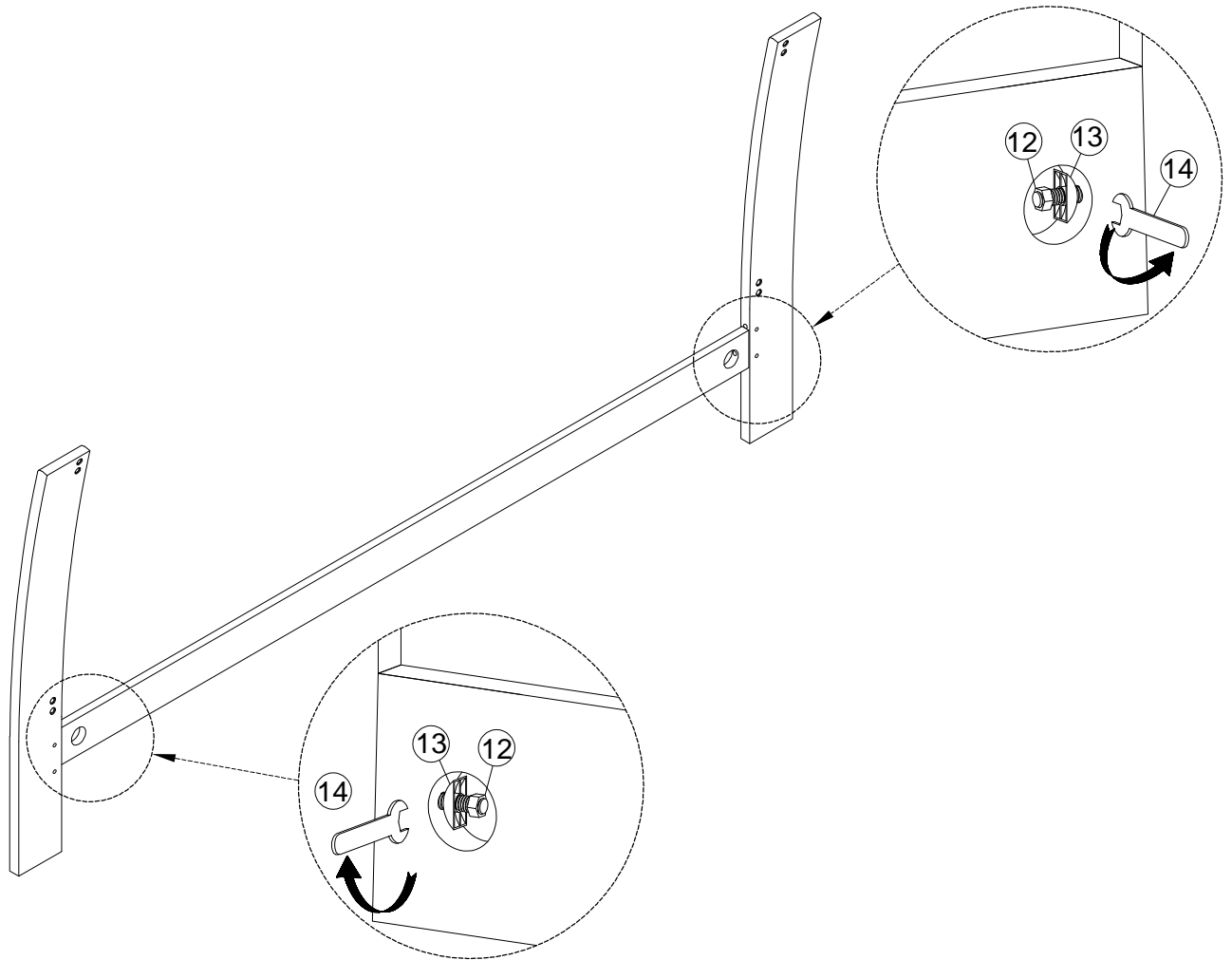

-Assemble the components in step 4 using a Half moon washer (13) Hex nut (12), and Open wrench (14) as shown in the image.

Do not fully tighten the Bolts.

Step 5:

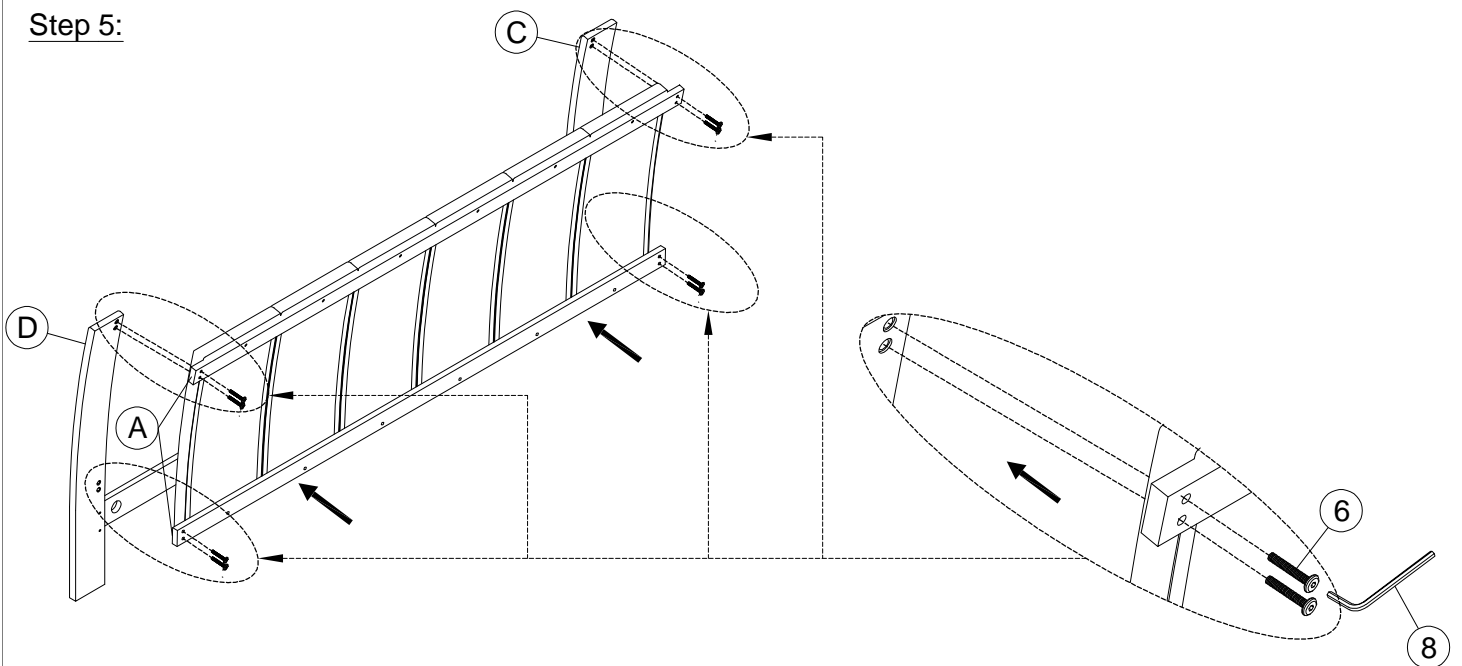

-Attach the Leg-left headboard (C) and Leg-right headboard (D) to the assembly completed in step 4 using Bolt (6) and Allen wrench (8) as shown in the image.

Do not fully tighten the Bolts.

Step 6:

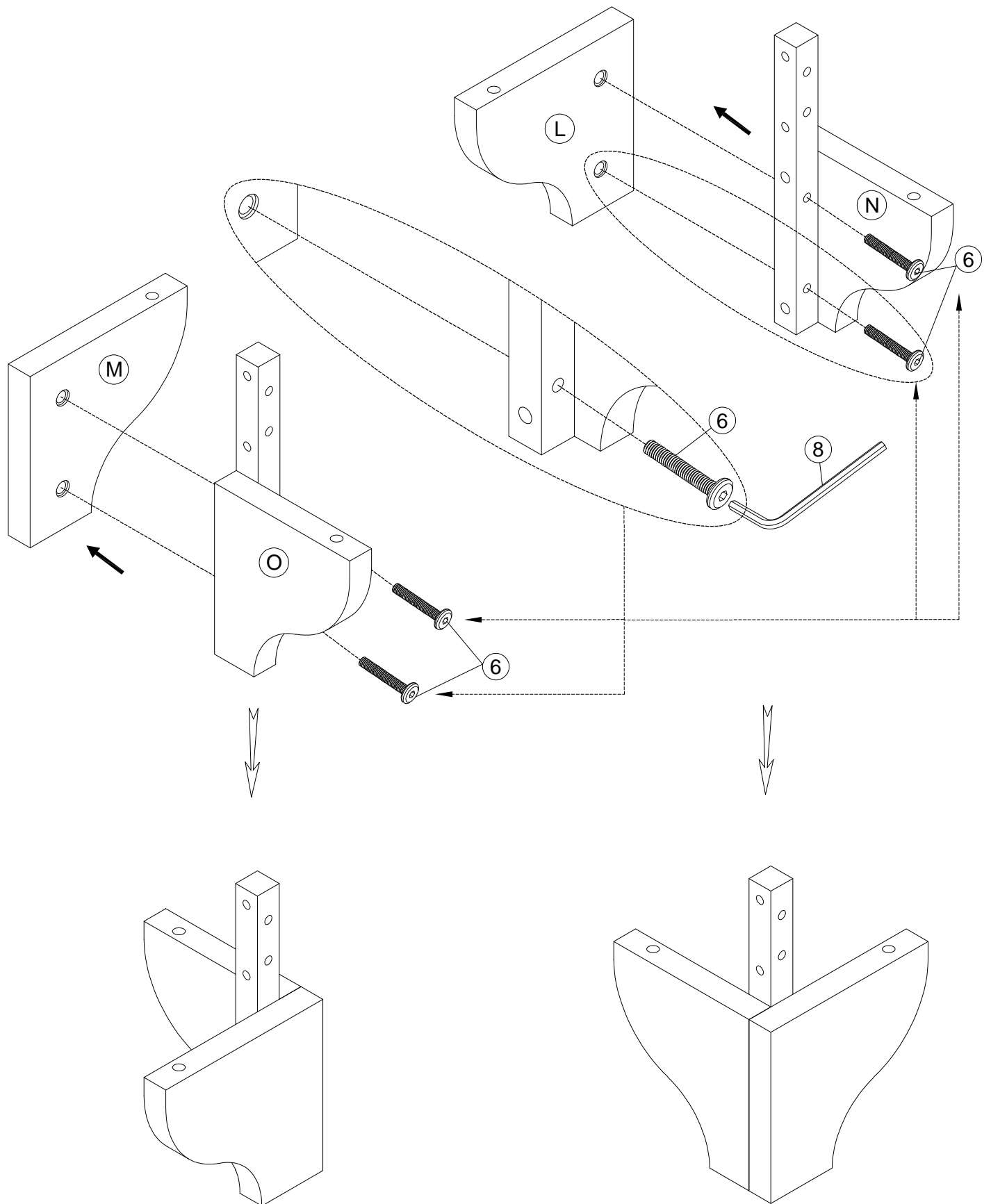

-Assemble the left front leg (L) to the left hip (N) and the right front leg (M) to the right hip (O) using Bolt ⑥ and Allen wrench ⑧ as shown in the image.
Do not fully tighten the Bolts.

Step 7:

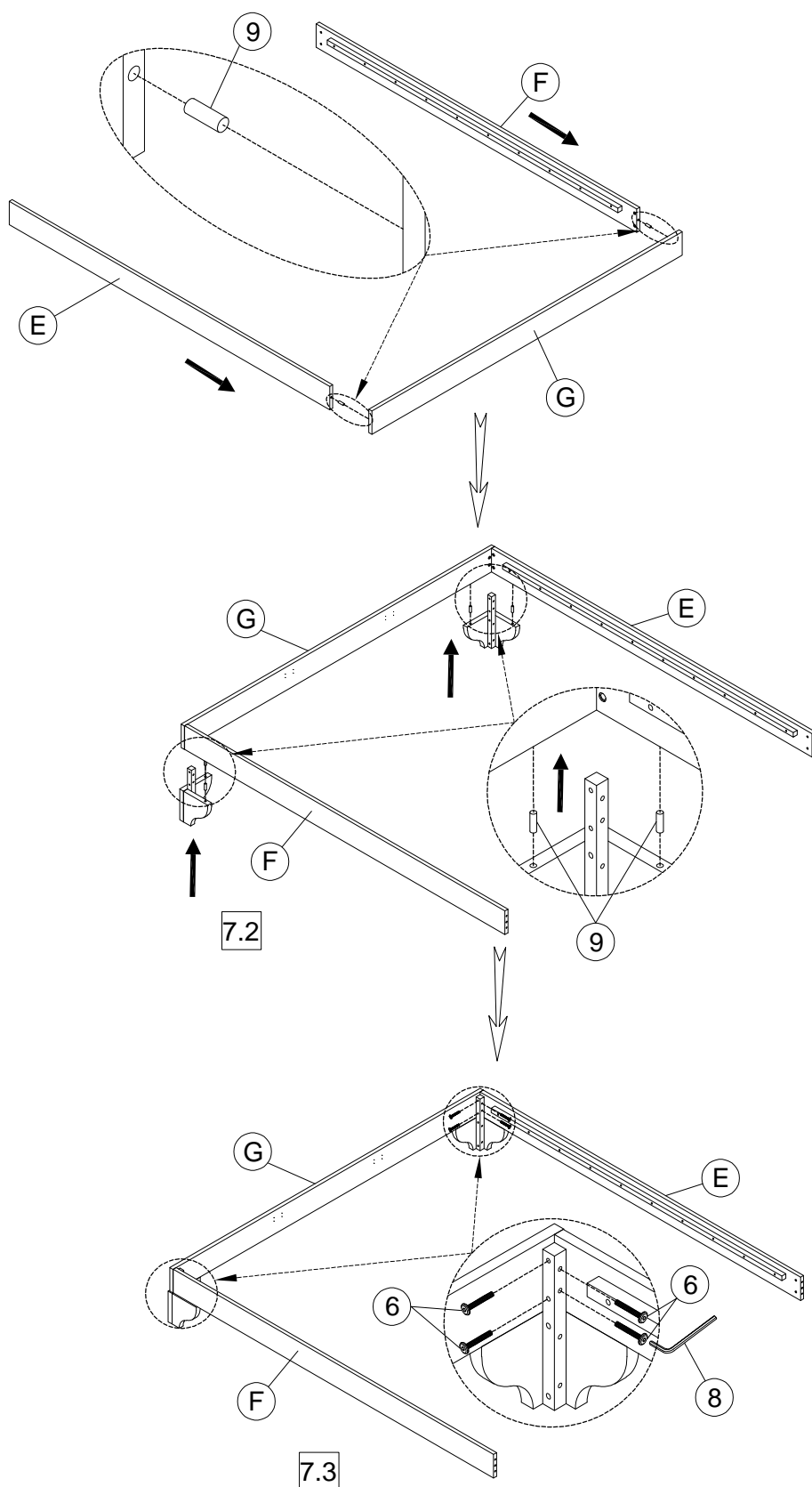

7.1: Attach the Left Side panel (E) and Right Side panel (F) to the Bed footboard (G) using Wooden dowel (9) as shown in the image.

7.2: The leg assembly from step 6 is attached to the assembly from step 7.1 using Wooden dowel (9) as shown, noting the left-right orientation.

7.3: The assembly in step 6 is connected using Bolt (6) and Allen wrench (8) as shown in the image. **Do not fully tighten the Bolts.**

Step 8:

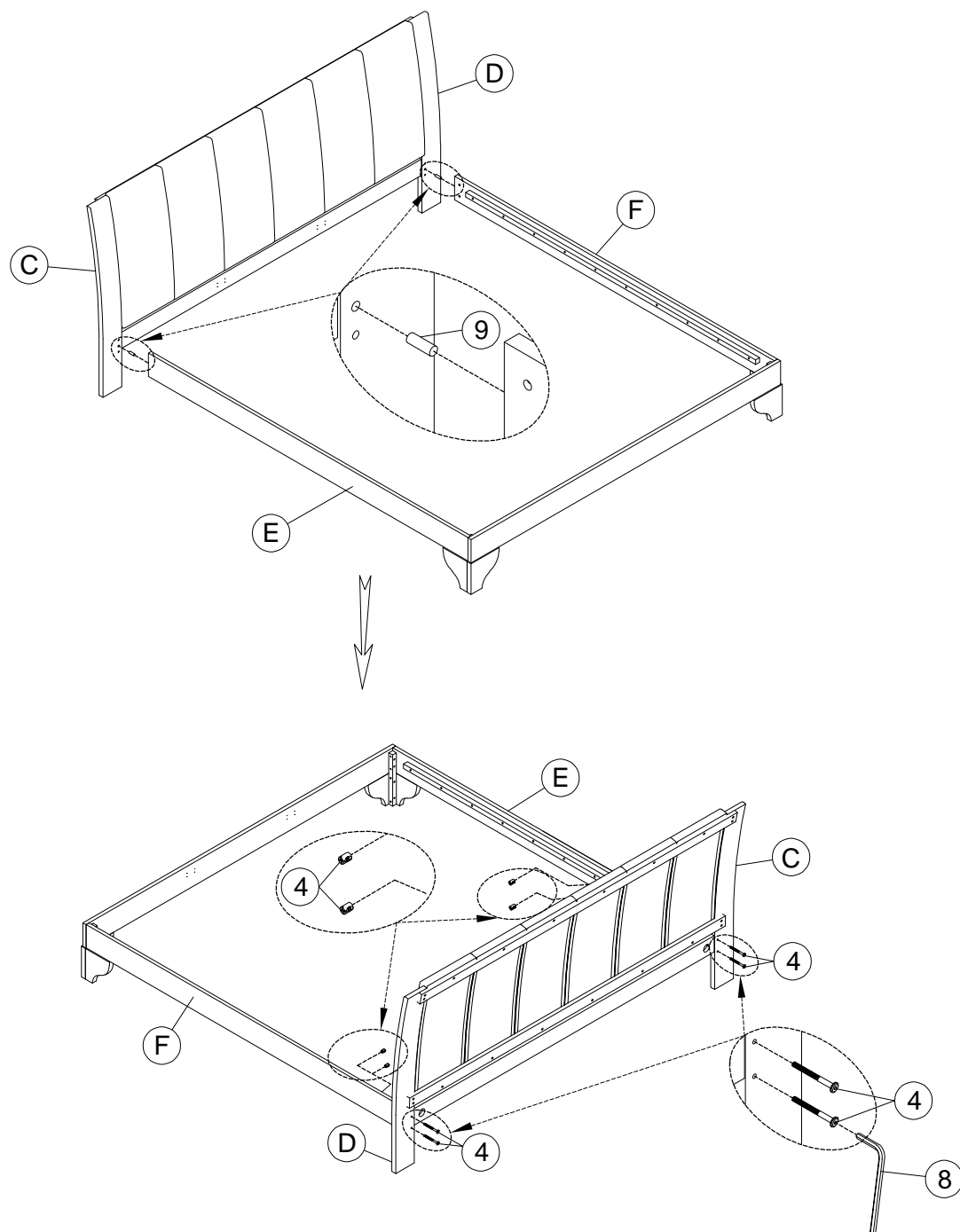

8.1: The assembly in step 7 connects to the assembly in step 5 using a wooden dowel (9) as shown in the image.

8.2: After completing step 8.1, we connect the assembly using Bolt (4) and Allen wrench (8) as shown in the image.

Do not fully tighten the Bolts.

Step 9:

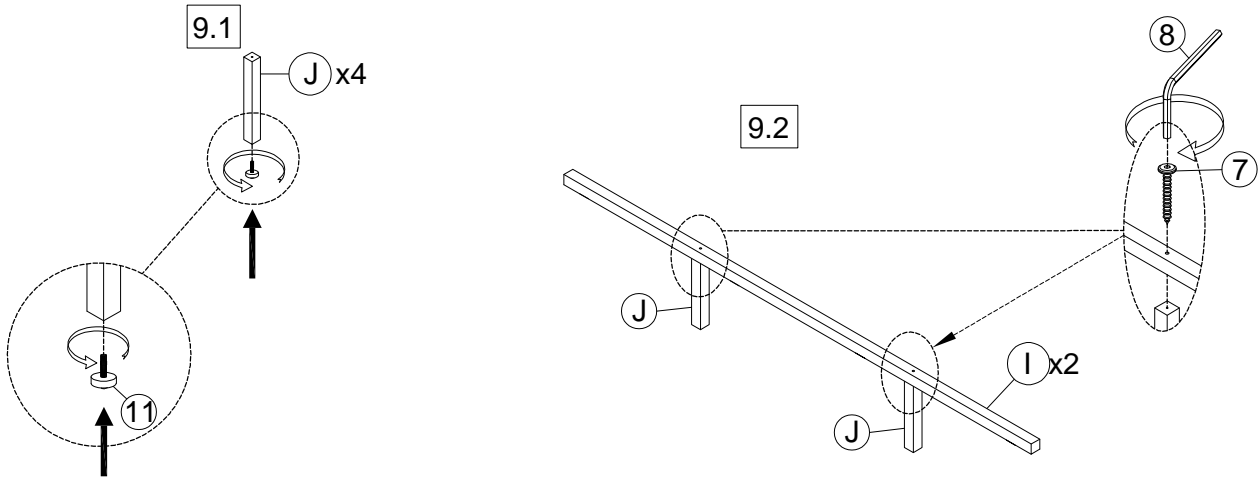

9.1: Attach Level (11) to Center support leg (J) as shown in the image.

9.2: After step 9.1, attach the Center support leg (J) to the Center rail (I) using Screws (7) and the Allen wrench (8) as shown in the image.

Do not fully tighten the Bolts.

Step 10:

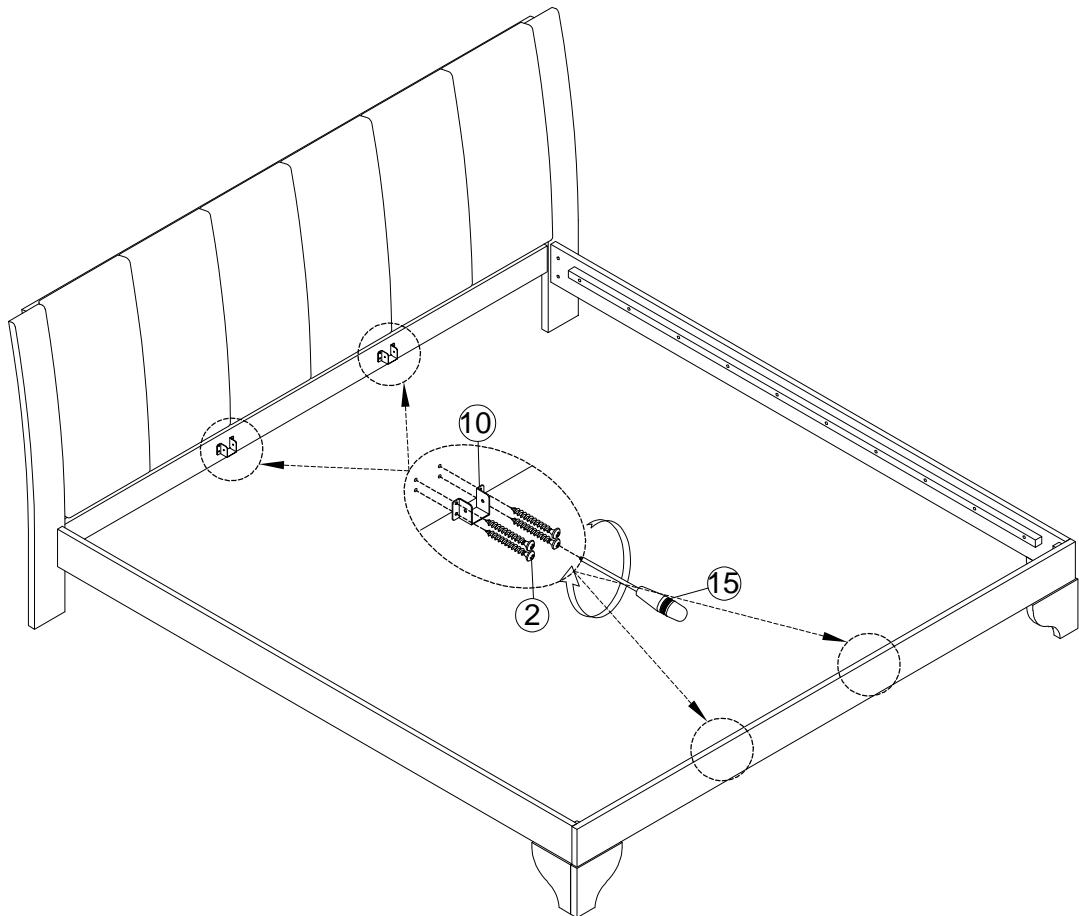

-Attach the Metal link (10) to the headboard using Vis Ø4x15mm (2) and Screwdriver (15) through the drilled hole positions as shown in the image.

Do not fully tighten the Bolts.

Step 11:

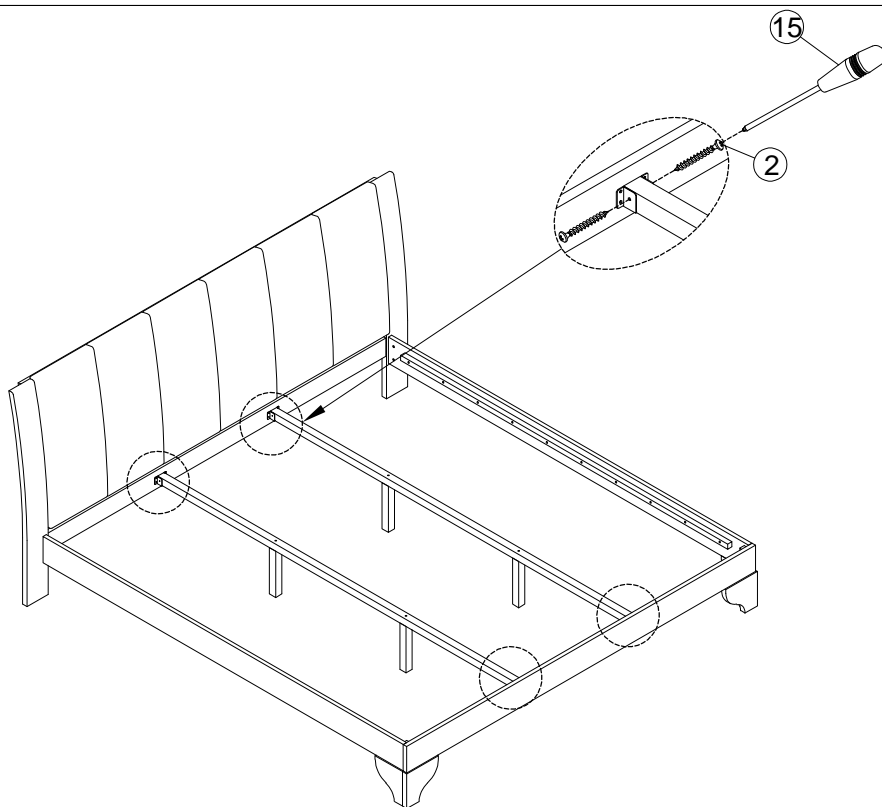

-Attach the assembly completed in step 9 to the Metal link ⑩ using Vis Ø4x15mm ② and Screwdriver ⑮ as shown in the image.
Do not fully tighten the Bolts.

Step 12:

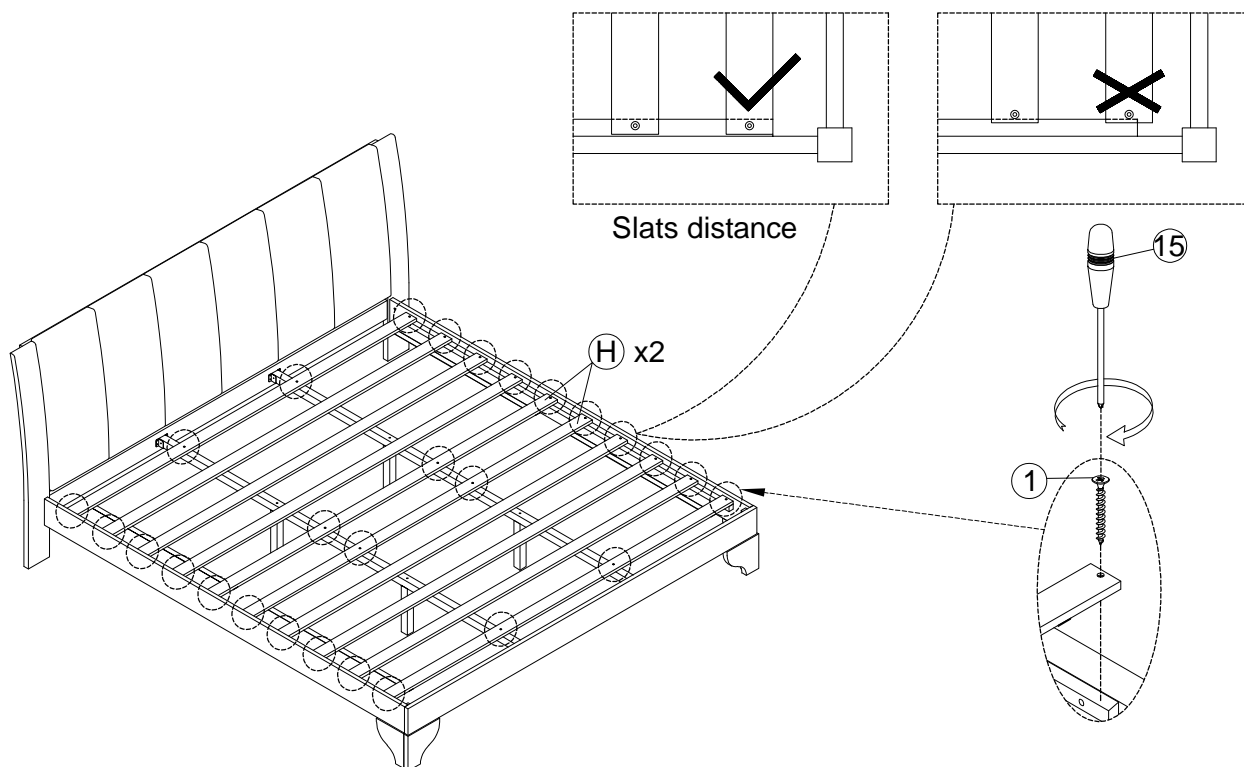

-Attach the Slats (H) to the bed frame as shown using Vis Ø4x30mm ① and Screwdriver ⑮ as illustrated.
TIGHTEN ALL HARDWARE 100%.

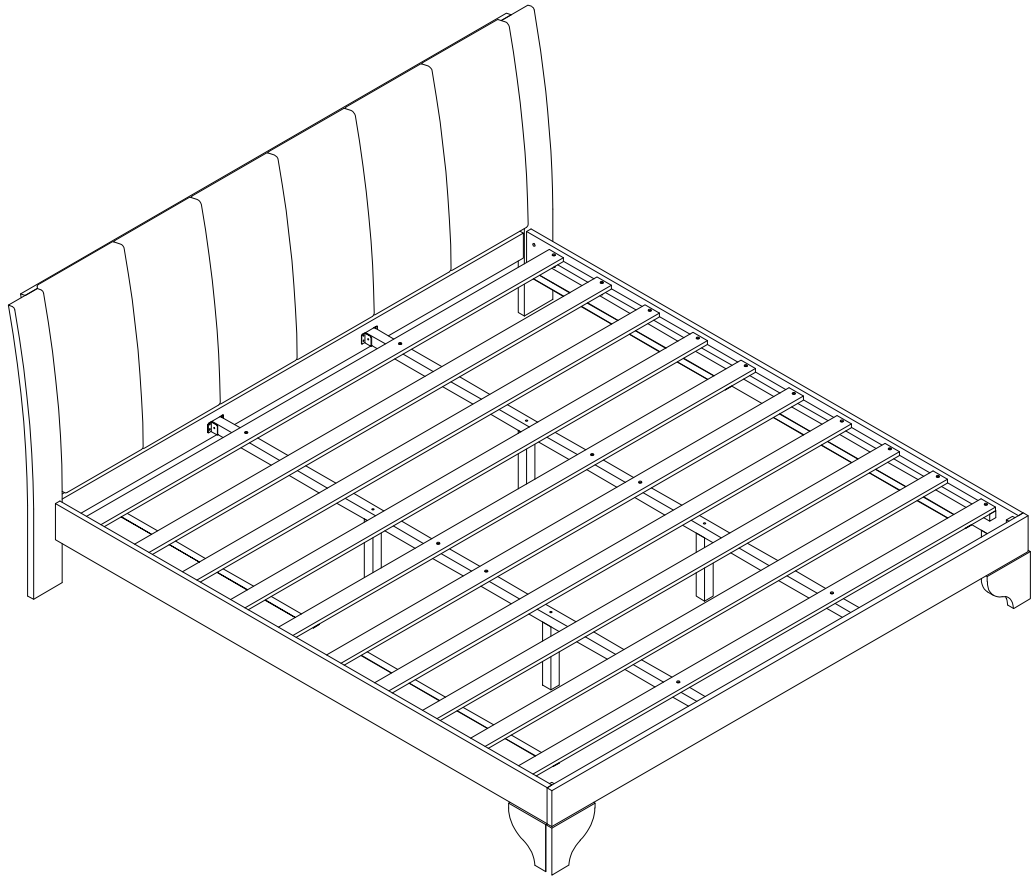

**Inspect the Bed and make sure all parts are adequately connected.
Adjust the Levelers to desired height to avoid wobbles.
Your bed is ready for use.**

CARE INSTRUCTIONS:

**Hardware may loosen overtime. Periodically check that all connections are tight.
Wipe with a soft, dry cloth. To protect finish, avoid the use of chemicals and household
cleaners.**