

NOTICE

*Please make sure that you have all part indicated and they are in good condition before you begin assembly of this item. Refer to part list and hardware list below for guidance.

*This item should be assembled on a soft surface to prevent scratching the finish during assembly.

*This item may require periodic tightening.

*If you are having difficulty, our friendly Customer Care team is always here to help.

PREPARATION

*Before beginning assembly of product, make sure all part are present. Compare part with part contents list and hardware contents list.

*If any part is missing or damaged, do not attempt to assemble the product.

*Estimated Assembly Time: 60 minutes.

*Tools Required for Assembly (included): Allen Key

CARE AND MAINTENANCE

Adhesive felt pads should always be applied to areas of furniture which make direct contact with flooring, said application will prevent damage to the furniture and or surfaces on which the furniture lies.

Objects placed on articles of furniture should rest on non abrasive material as to prevent damage to the wood finish. Objects whose composition consists of plastic and rubber are known to discolor and damage the wood surfaces on which they rest. Wipe up spills immediately and avoid common hazards such as hot dishes, harsh solvents and abrasives. Cleaning should be done with a soft lint free cotton cloth dampened with water or furniture polish. On highly used surfaces we recommend applying a quality paste wax which should be used on a regular basis to provide additional protection from scratches and spills.

How often you apply the wax depends on how much wear the furniture receives

Part List

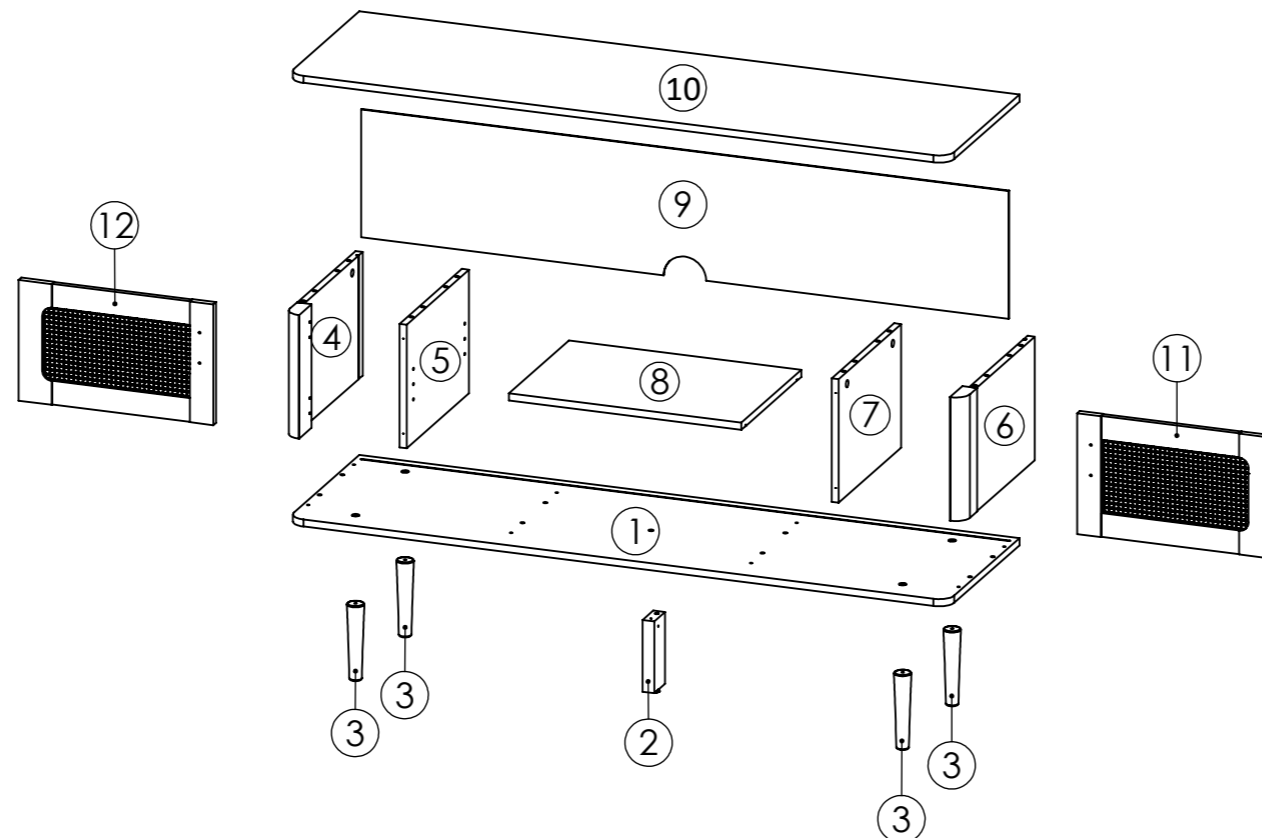

OWNER MANUAL

Product Dimensions: W 55.12" x 15.75" x 17.83"

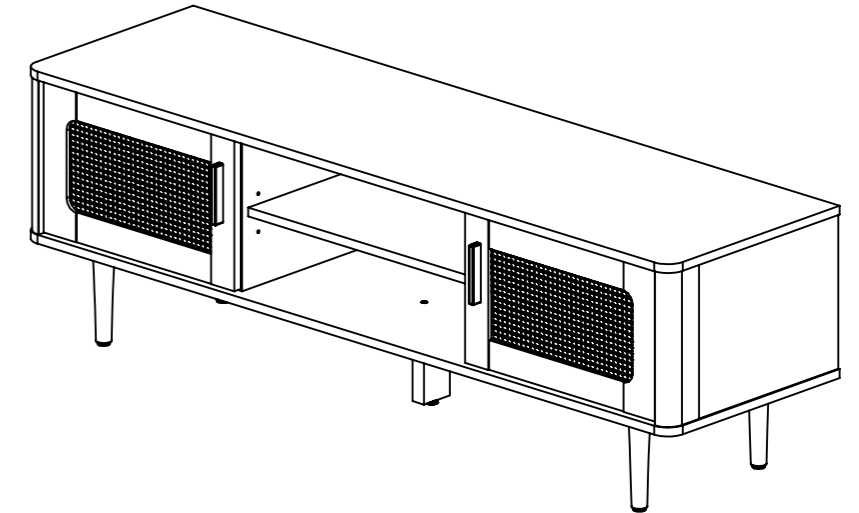







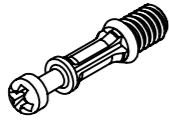
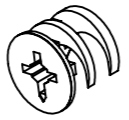
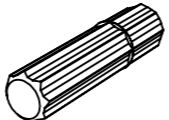

WARNING

This product is intended for use with a
FLAT SCREEN TV ONLY
Maximum Screen Size: 55 inches
Top Weight Limit: 48 lbs
Shelf Load Limit: 14 lbs
Drawer Load Limit : 4 lbs
Use with heavier televisions may result in
instability causing tip over resulting in death
or Serious injury.

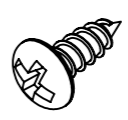
WARNING

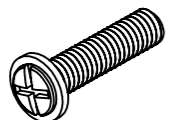
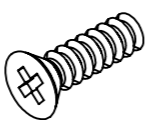
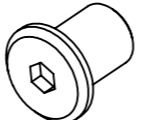
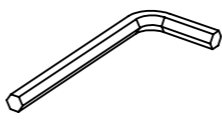
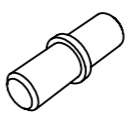
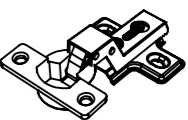
Death or serious injury may occur
when children climb on audio and/or video
equipment furniture.
A remote control or toys placed on
the furnishing may encourage a child to climb on
the furnishing and
as a result the furnishing may tip
over on to the child

Hardware List

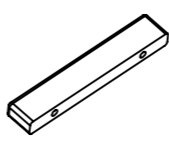
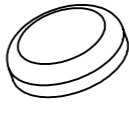
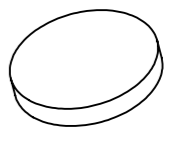
<p>HW1x8 ϕ 6X32 mm</p> 	<p>HW2x8 ϕ 12X15 mm</p> 	<p>HW3x17 ϕ 8X32 mm</p> 	<p>HW4x9 ϕ 6X50 mm</p> 	<p>HW5x4 ϕ 6X12 PH</p> 	<p>HW6x10 ϕ 4X19 mm</p> 
<p>HW7x4 ϕ 4X25 mm</p> 	<p>HW8x16 ϕ 5X12 mm</p> 	<p>HW9x4 Nut Cap</p> 	<p>HW10x1 L4 mm</p> 	<p>HW11x4 Metal Pin</p> 	<p>HW12x4 Full curve</p> 
<p>HW13x10 Plastik Stopper</p> 	<p>HW14x2 Plate L</p> 	<p>HW15x8 Cover Cap</p> 	<p>HW16x2 Handle</p> 	<p>HW17x4 Bumpers</p> 	<p>HW18x4 Foot Pads</p> 

Part List & HW

piece	Description	Qty	Carton Call
1	Bottom Panel	1	1 of 1
2	Center Legs	1	1 of 1
3	Side Legs	4	1 of 1
4	Side Panel -Left	1	1 of 1
5	Divider Panel -Left	1	1 of 1
6	Side Panel -Right	1	1 of 1
7	Divider Panel -Right	1	1 of 1
8	Adjustable Shelf	1	1 of 1
9	Back Panel	1	1 of 1
10	Top Panel	1	1 of 1
11	Door Panel -Right	1	1 of 1
12	Door Panel -Left	1	1 of 1

Piece	Description	Qty	Carton Call
HW1	Cambolt	8	1 of 1
HW2	Camlock	8	1 of 1
HW3	Wooden Dowel	17	1 of 1
HW4	Screw M6 x 50 mm	9	1 of 1
HW5	Screw M6 x 12 PH	4	1 of 1
HW6	Screw M4 x 19 mm	10	1 of 1
HW7	Bolt M4 x 22 mm	4	1 of 1
HW8	Screw M5 x 12 mm	16	1 of 1
HW9	Nut Cap 6 x 12 mm	4	1 of 1
HW10	Allen Key	1	1 of 1
HW11	Metal Pin	4	1 of 1
HW12	Full Curve Hinge	4	1 of 1
HW13	Plastic Stopper	10	1 of 1
HW14	Plate L	2	1 of 1
HW15	Cover Cap Sticker	8	1 of 1
HW16	Handle	2	1 of 1
HW17	Bumpers	4	1 of 1
HW18	Foot Pads	4	1 of 1

PREPARATION

Before beginning assembly of product, make sure all part are present. Compare part with part contents list and hardware contents list.
If any part is missing or damaged, do not attempt to assemble the product.
Estimated Assembly Time: 60 minutes.

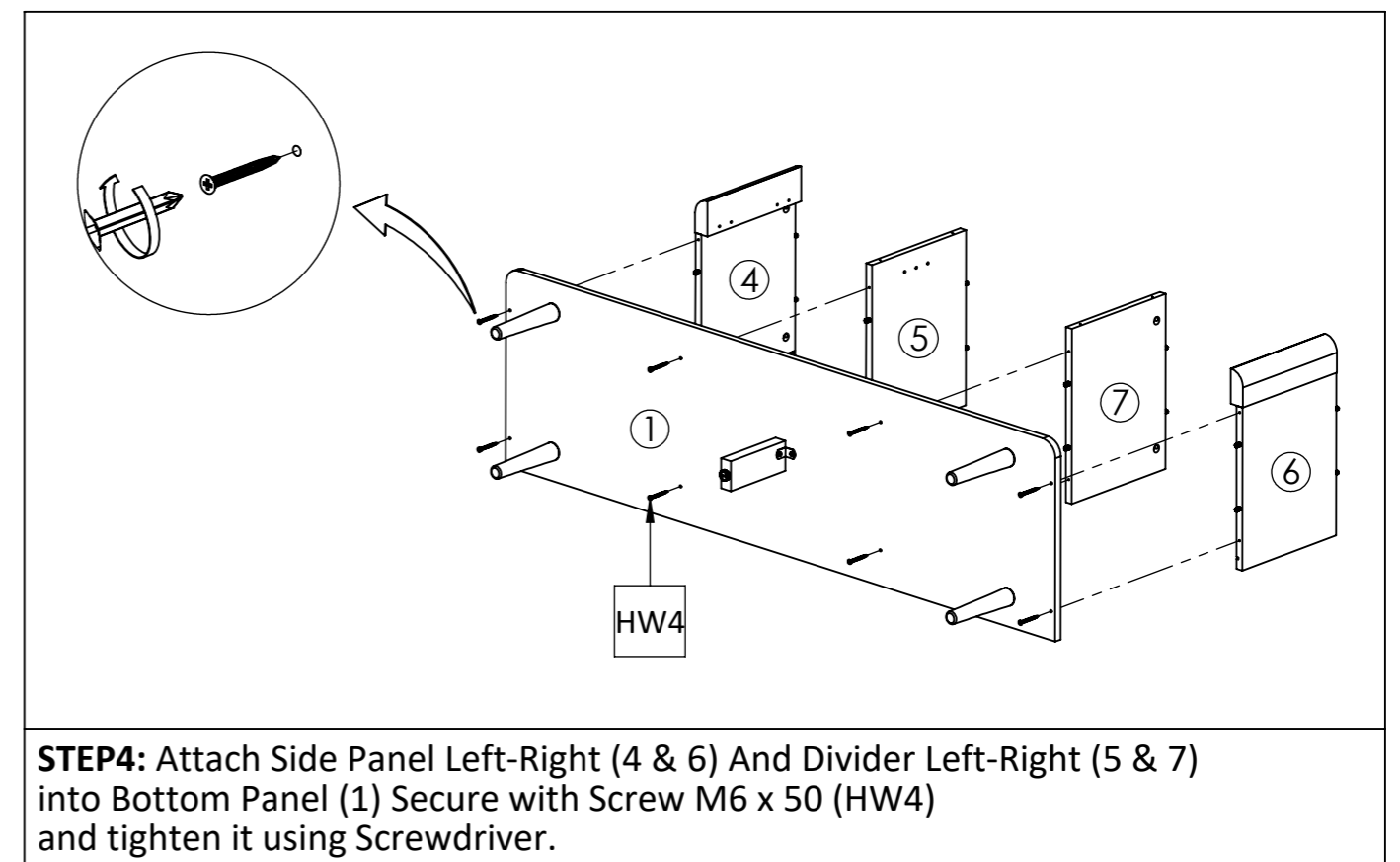
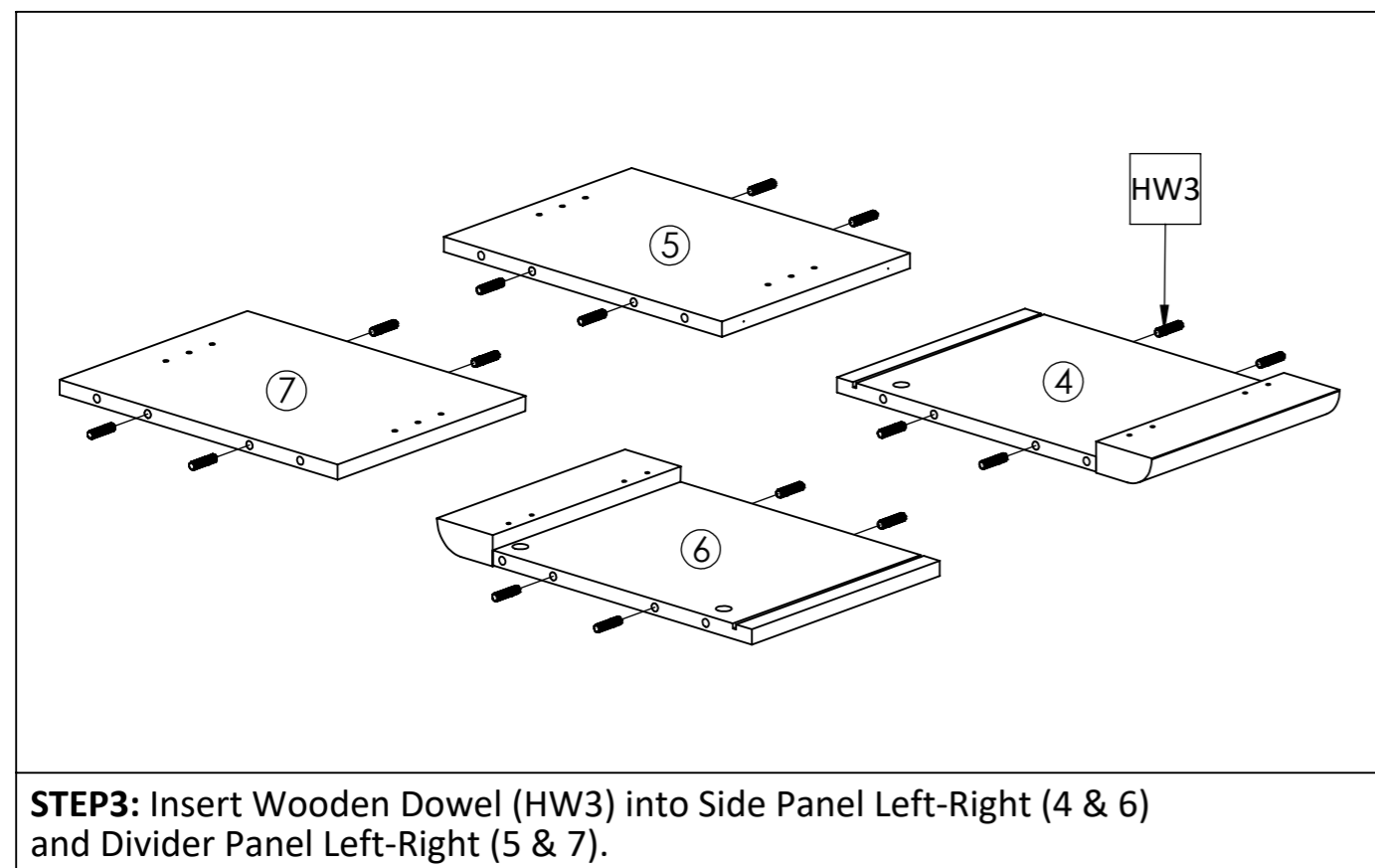
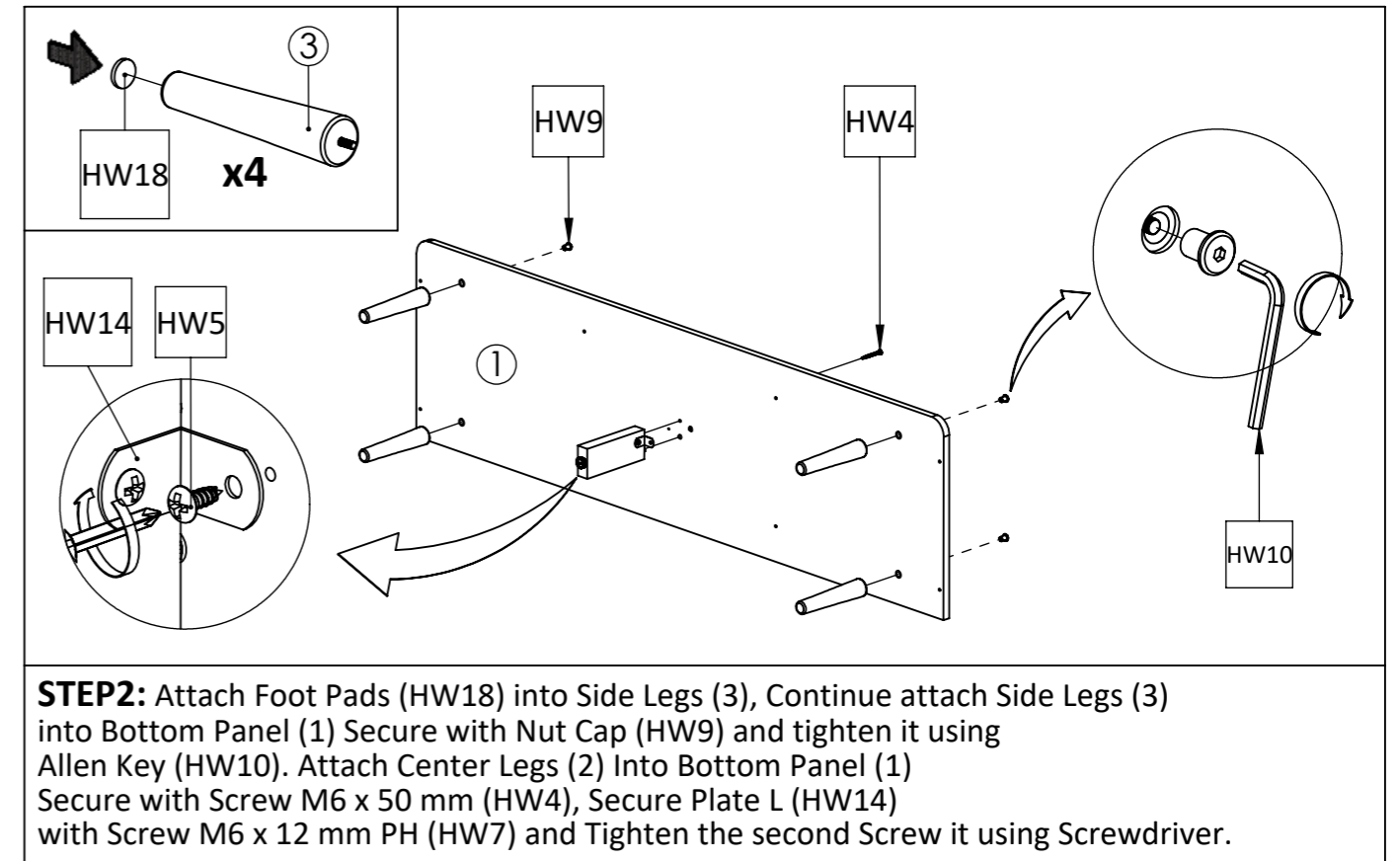
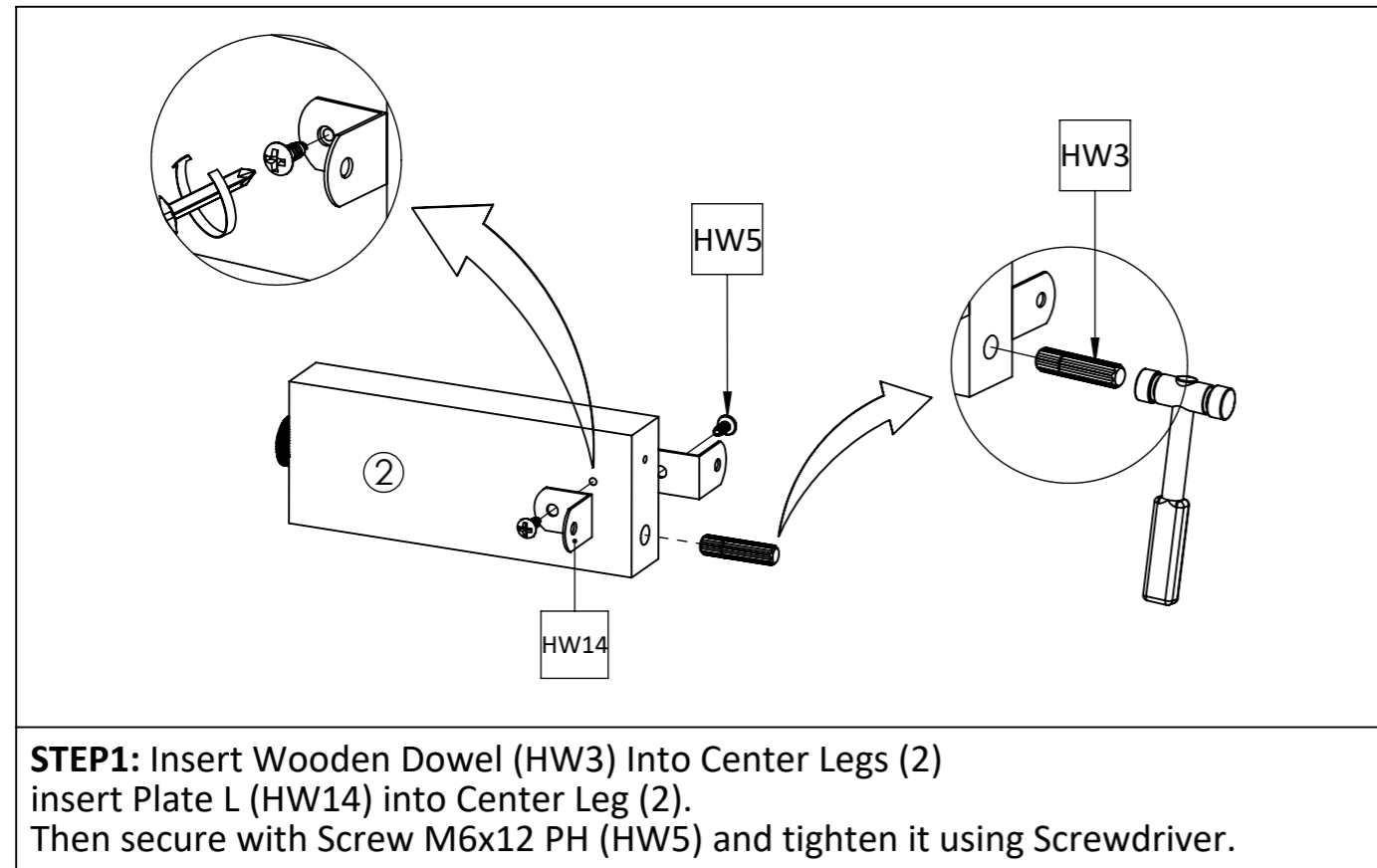

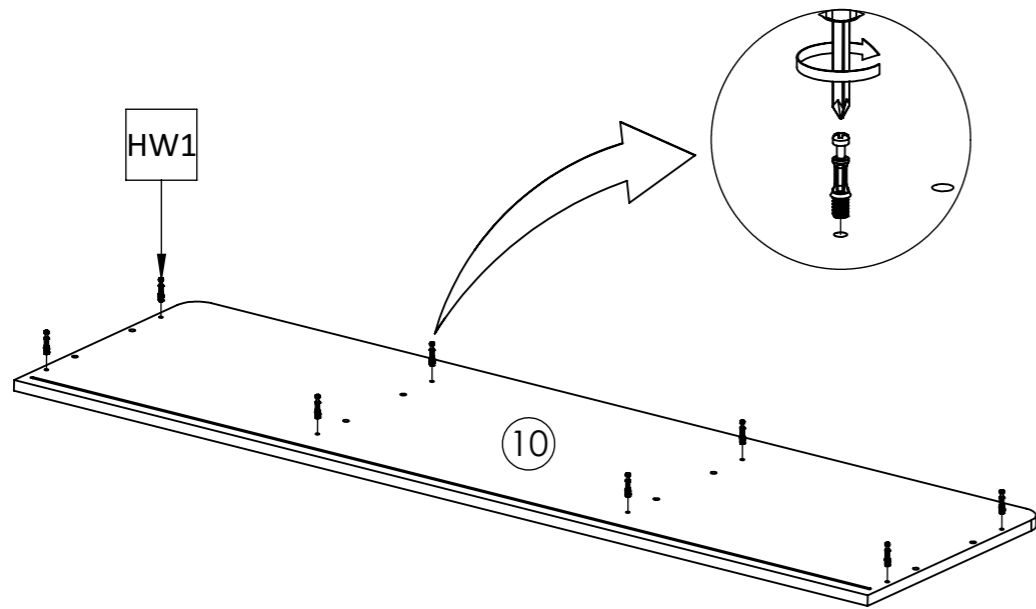

STEP5: Insert Cambolt (HW1) into Top Panel (10) and tighten it using Screwdriver.

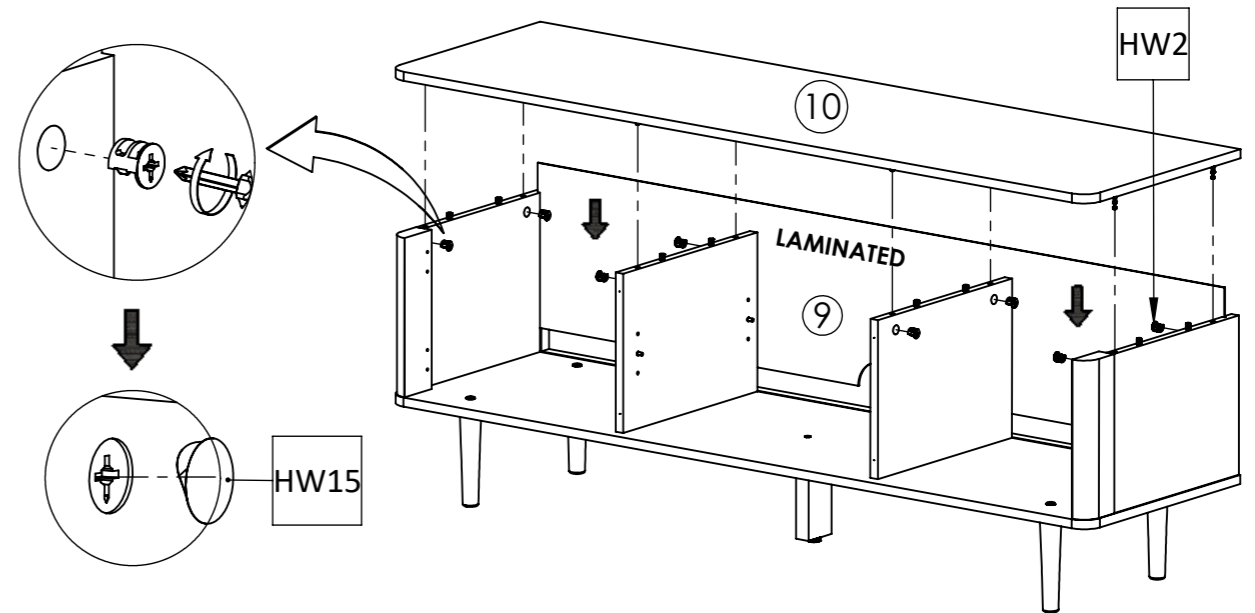

STEP6: Insert Back Panel (9), Attach Top Panel (10) Secure with Camlock (HW2) and tighten it using Screwdriver. Continue attach the cover cap sticker (HW15) to the panel that has lamination.

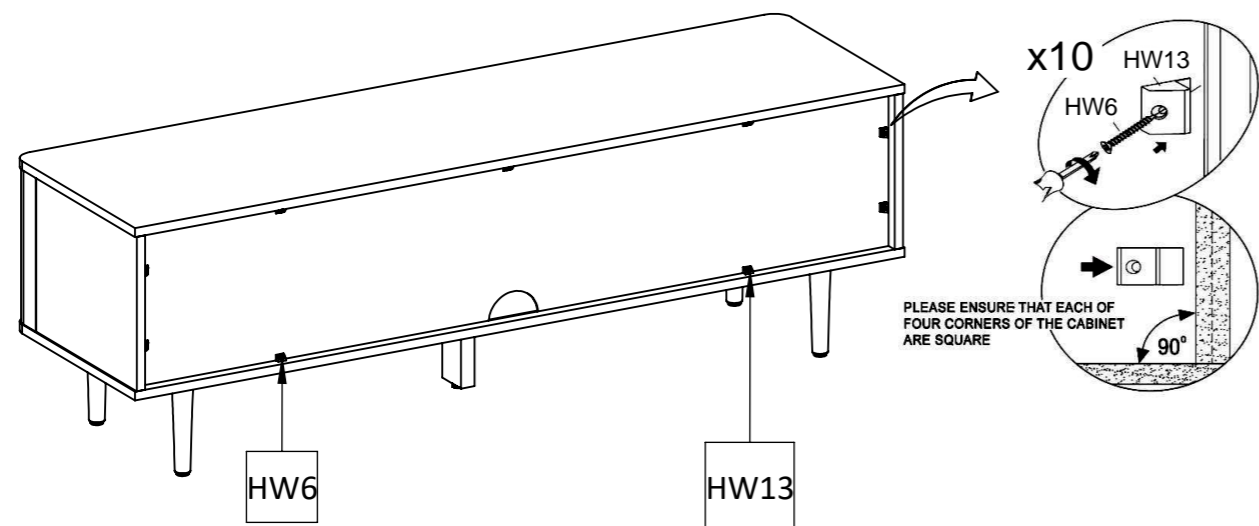

STEP7: Attach the plastic stopper (HW13) to the back panel Secure with screw M4x19 mm (HW6) and tighten it using screwdriver.

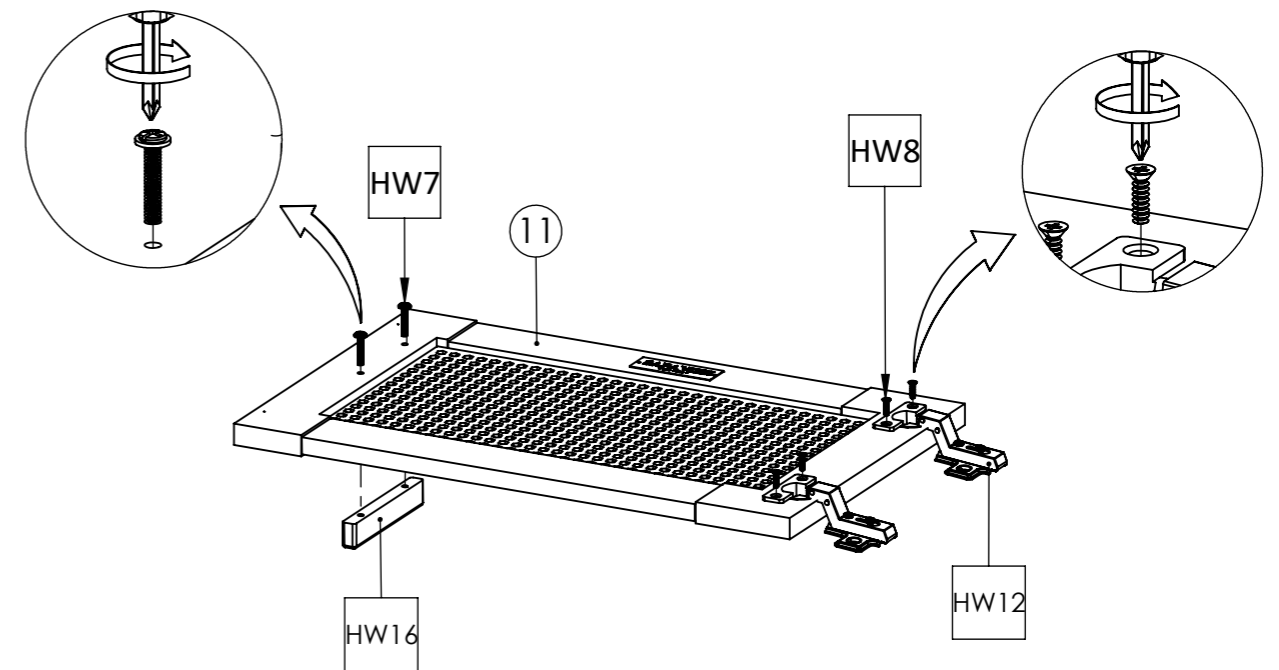

STEP8: Insert Handle (HW16) into Door Panel -Right (11) secure with Bolt M4 x 22 (HW7) and tighten it using Screwdriver, Continue insert Full Curve Hinge (HW12) into Door Panel -Right (11), secure with Screw M5 x 12 (HW8) and tighten it using Screwdriver.

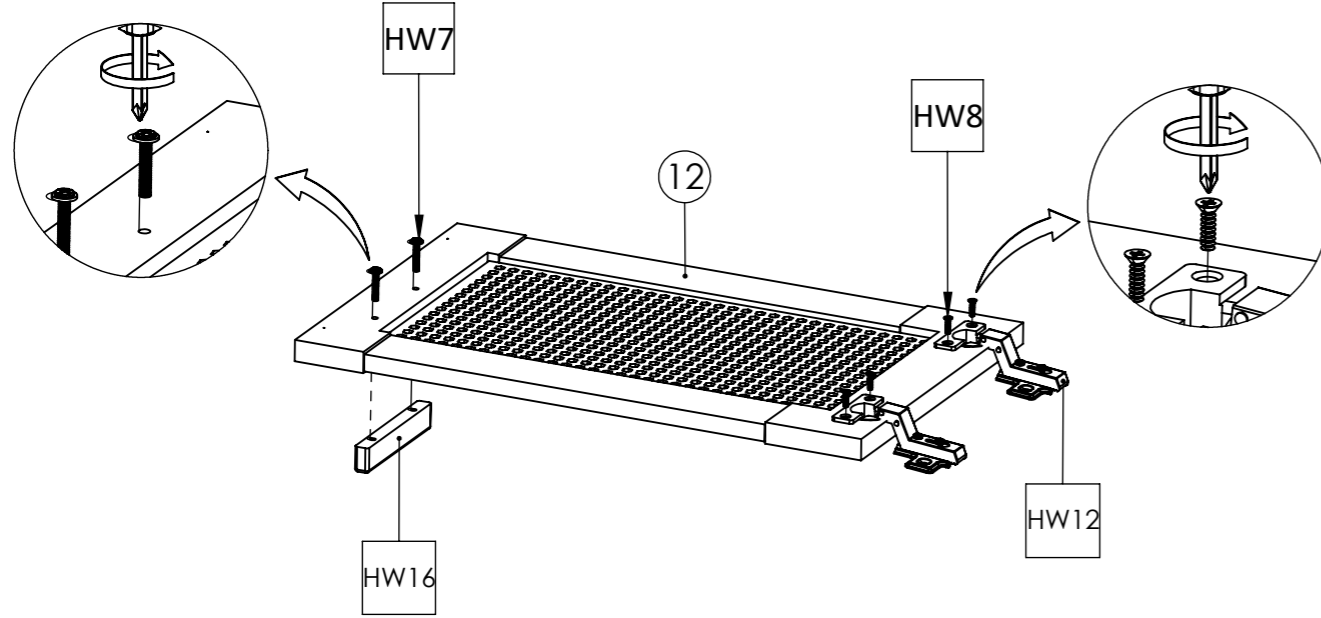

STEP9: Insert Handle (HW16) into Door Panel -Left (12) next secure with Bolt M4 x 22 (HW7) and tighten it using Screwdriver, Then insert Full Curve Hinge (HW12) into Door Panel -Left (12), Next secure with Screw M5 x 12 (HW8) and tighten it using Screwdriver.

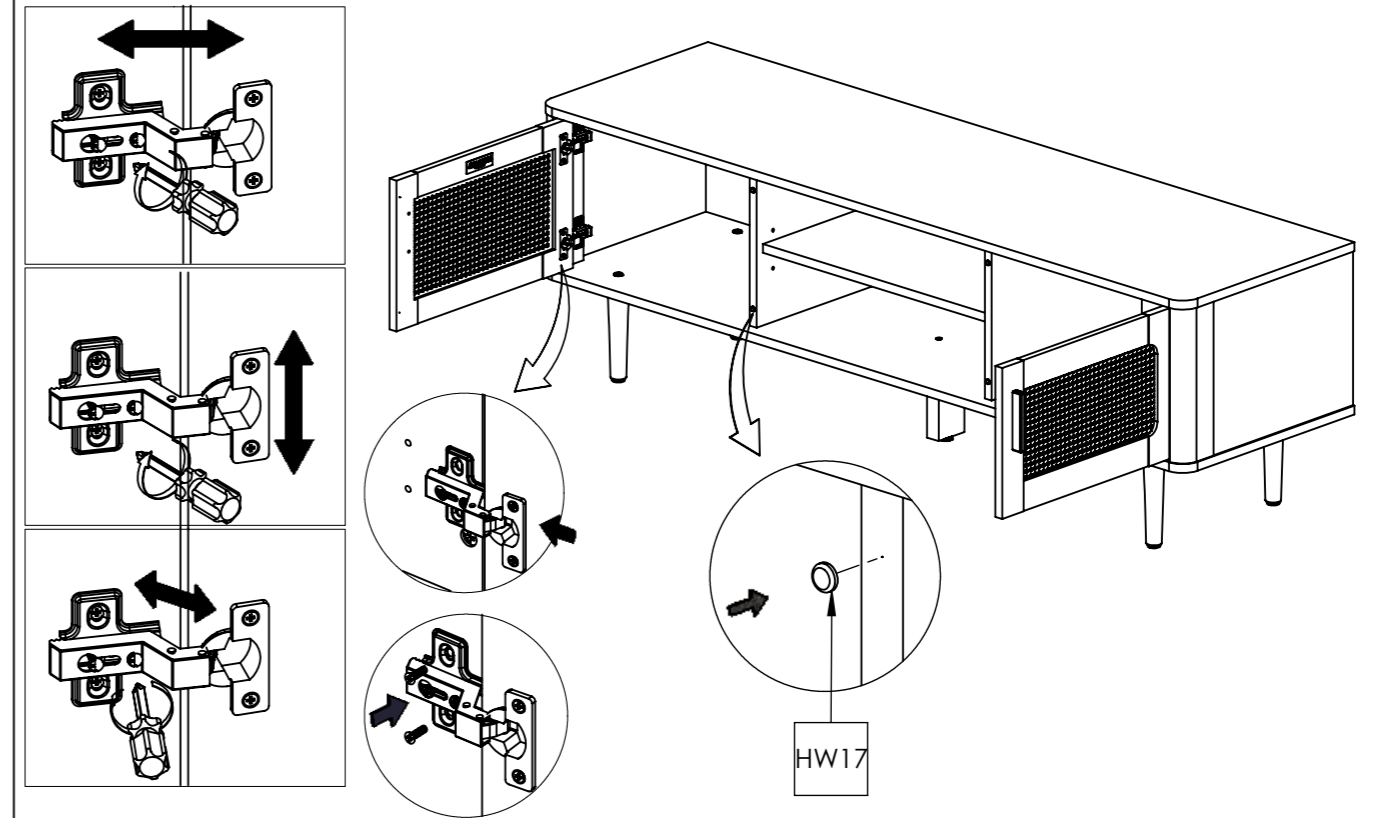

STEP10: Set Full Curve Hinge (HW12) Continue attach Bumpers (HW17) into Divider Panel Left-Right (1).

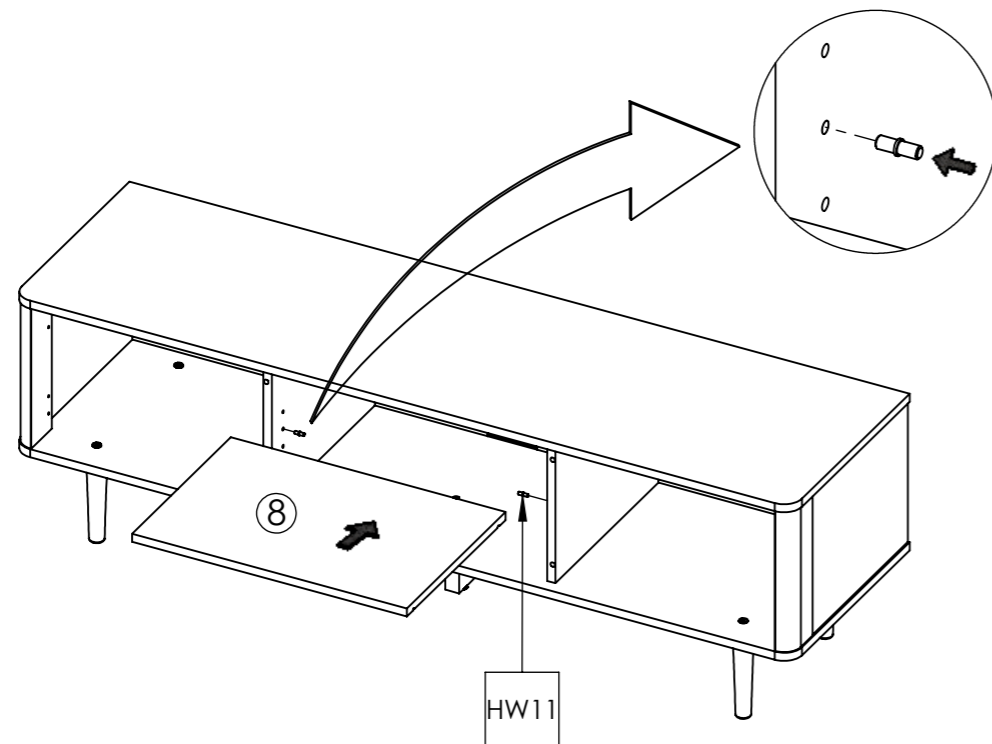

STEP11: Attach Metal Pin (HW11) into Divider Panel Left-Right (5 & 7), Continue attach Adjustable Shelf (8).

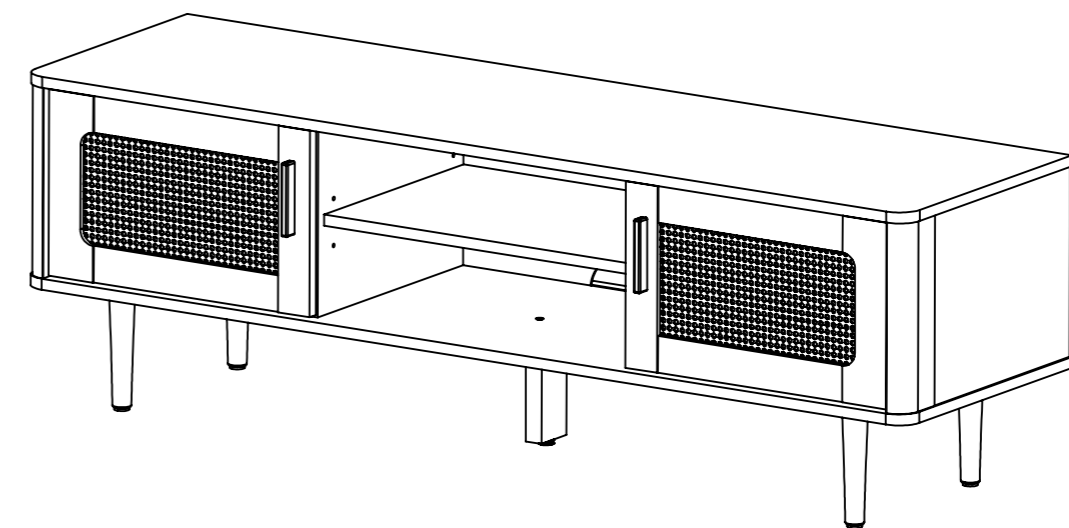

STEP12: Assembly is complete.