

ASSEMBLY INSTRUCTIONS

PARTS PACKING CONFIGURATIONS

- A. CHAIR BACK 1 PC
- B. SEAT CUSHION 1 PC
- C. CHAIR LEG 2 PCS

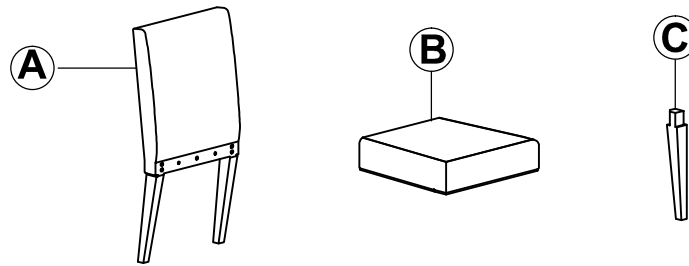

HARDWARE ENCLOSED IN CARTON

No	Description	Photo	Quantity
1	ALLEN BOLT (5/16 x 2)		4 PCS
2	ALLEN BOLT (5/16 x 3)		4 PCS
3	ALLEN BOLT (5/16 x 1-3/4)		1 PC
4	LOCK WASHER (5/16)		9 PCS
5	FLAT WASHER (5/16)		9 PCS
6	ALLEN KEY		1 PC

FULLY ASSEMBLED

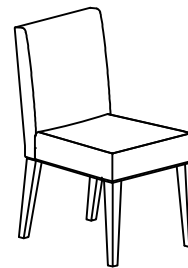
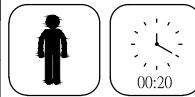

STEP 1:

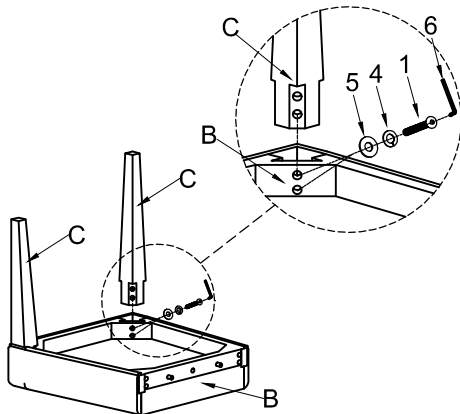

DO NOT TIGHTEN BOLTS COMPLETELY

STEP 2:

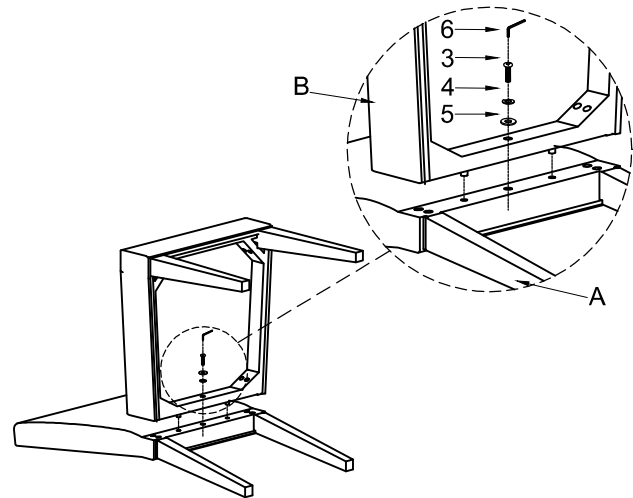

DO NOT TIGHTEN BOLTS COMPLETELY

STEP 3:

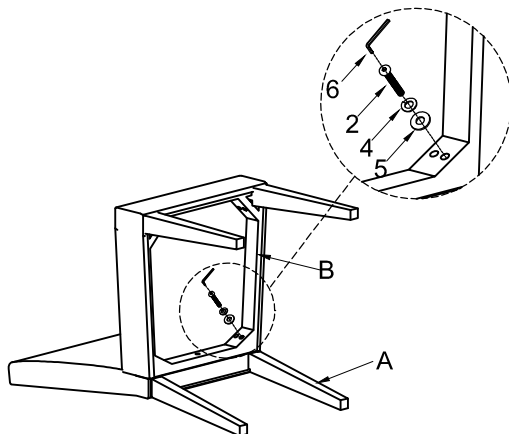

DO NOT TIGHTEN BOLTS COMPLETELY

STEP 4:

ON A FLAT, LEVEL SURFACE PLACE THE CHAIR UPRIGHT. WHEN CHAIR IS LEVELLED, PLEASE TIGHTEN ALL ASSEMBLY BOLTS WITH PROVIDED ALLEN KEY.

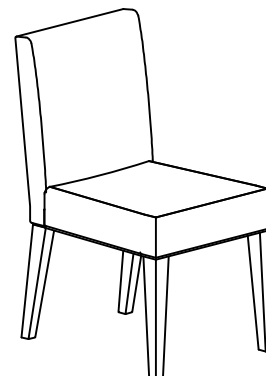

FULLY ASSEMBLED