

# ASSEMBLY INSTRUCTIONS

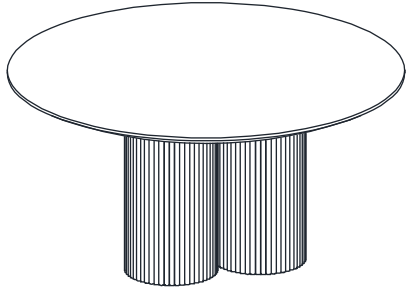

## + Do Not Use Power Tools



## + Suggested Adults



### NOTE:

- 1 Read instructions cover to cover.
- 2 Save all packaging until assembly is completed.

## 1 IMPORTANT SAFETY INFORMATION

**Do not** assemble the product if any of the following parts arrived damaged:

PART# ① -Table Top

PART# ② -Base

## 2 IMPORTANT ASSEMBLY INFORMATION

**Assembly Step 1:** Use wrench C to drive B fitted with iron plate A to connect part ② in top

**Assembly Step 2:** Use wrench C to drive B fitted with iron plate A to connect part ② in bottom

**Assembly Step 3:** Use wrench C to drive B fitted to fasten ② to ①

**\*Warning:** Do not over tighten screws, or it could damage the Table Top.

## + Parts Included

- ① Table top (1/pc)

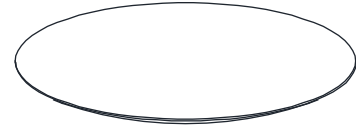

- ② Base (3/pcs)

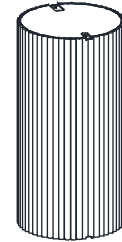

## + Hardware Included

A Iron plate  
(9/pcs)



B boltsM6X19  
(18/pcs)



C 4# wrench  
(1/pc)



# ASSEMBLY INSTRUCTIONS

1

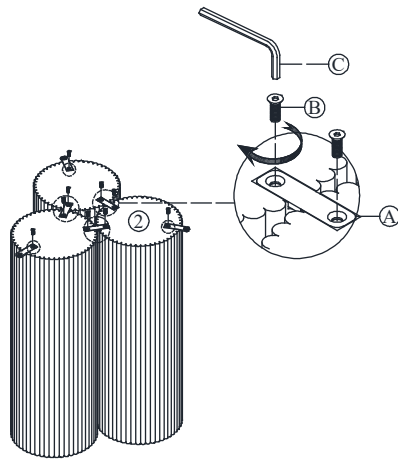

**Note:** Do not over tighten screws

2

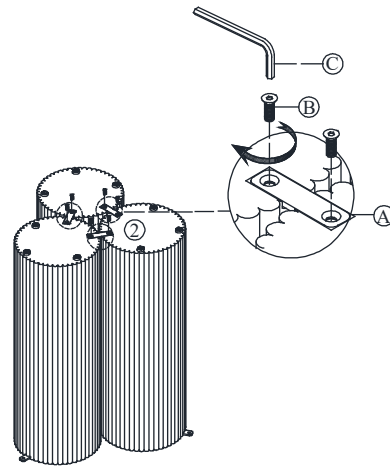

3

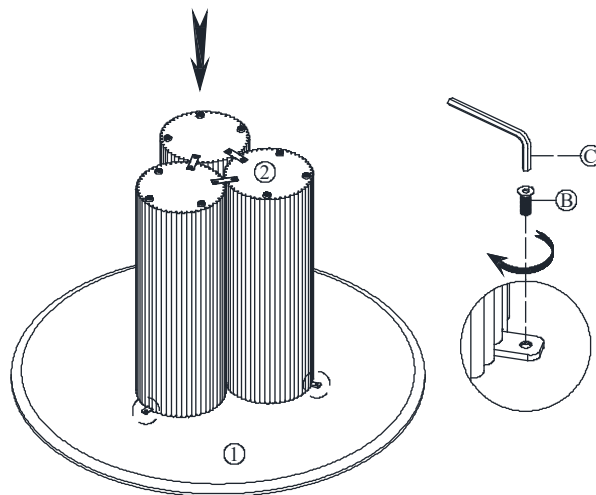

**Note:** Do not over tighten screws

4

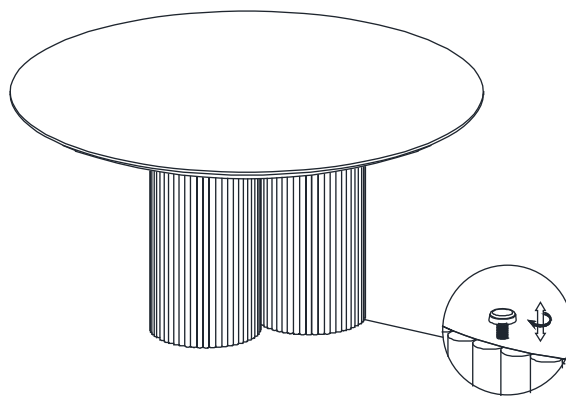

The assembly of the table is complete