



## EMILE SINGLE PAPER HOLDER

### FEATURES

---

- Solid brass construction
- Easy installation mounting brackets

### COLORS/FINISHES

---

- #CP Polished Chrome
- #BN Brushed Nickel



### INSTALLATION NOTES

---

Please refer to the installation manual for further instructions.

### WARRANTY

---

- Five-year Limited Warranty for residential use
- One-year Limited Warranty for commercial use

### SHIPPING INFORMATION

---

Package Dimensions  
8 7/16" x 4 5/16" x 2 3/16"  
Package Weight  
0.7 lbs

### MATERIAL

---

- Brass
- Zinc



DIMENSIONS

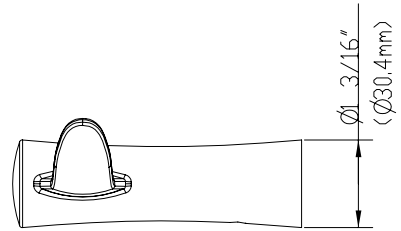
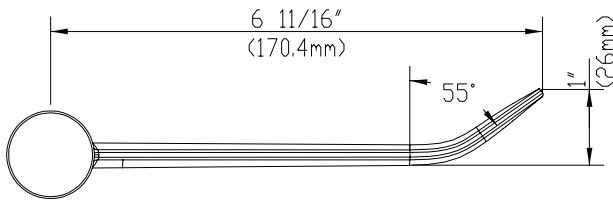
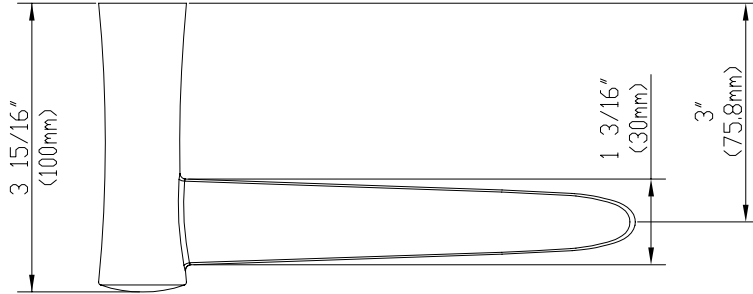

SERVICE PARTS

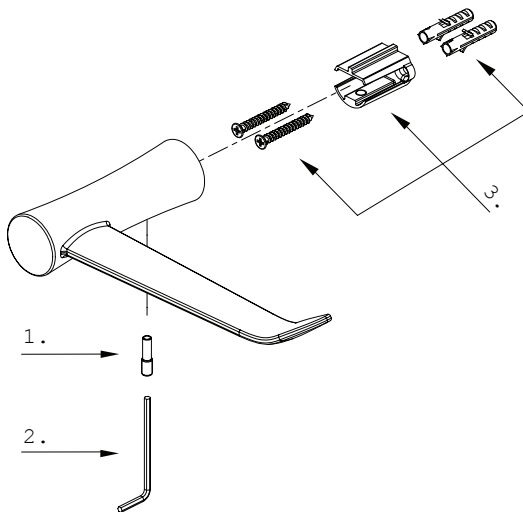

1. Screw (M5\*19mm L) (RB0123)
2. Allen Key (A031000)
3. Mounting Hardware (RB0125)

COPYRIGHT © COOPER AND GRAHAM 2018. ALL RIGHTS RESERVED.