

**CARE AND MAINTENANCE**

Spot clean using a mild water-free solvent. Only a professional cleaner should undertake a complete overall cleaning.

The use of steam or water-based cleaners may cause excessive shrinking or staining.

**NOTICE**

\*Please make sure that you have all parts indicated before you begin assembly of this  
 \*This item should be assembled on a soft surface to prevent scratching the finish during assembly

\*This item may require periodic tightening

Product Dimensions:24.4"W X 34.05"D X 32.28"H

**Part List**

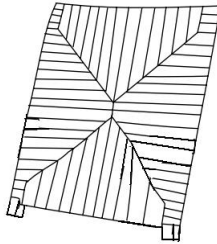
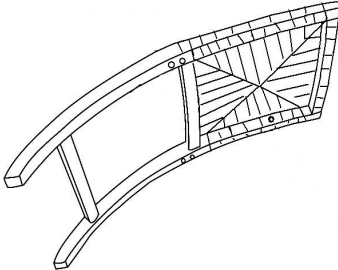
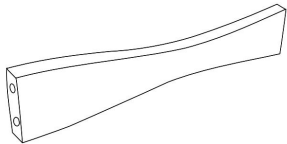
PIECE	DESCRIPTION	PICTURE	QUANTITY
A	Back		1X
B	Seat		1X
C	Seat Rail		1X

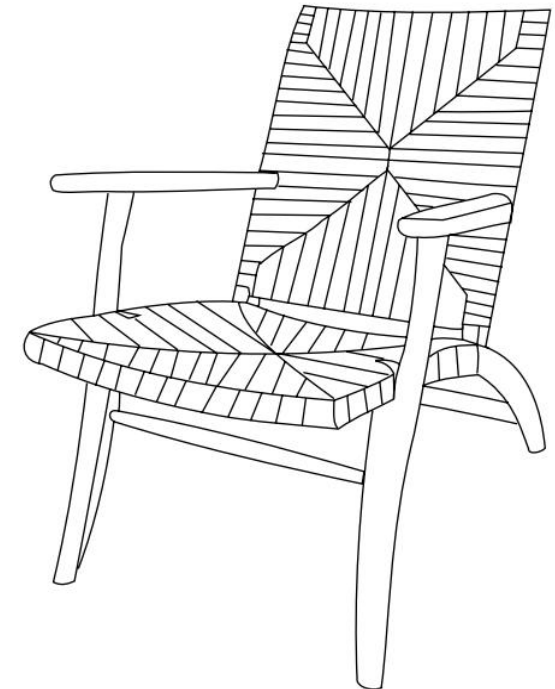



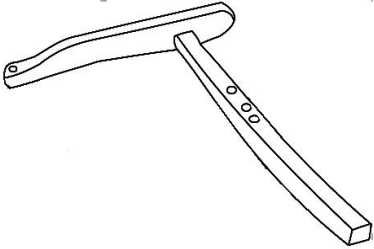
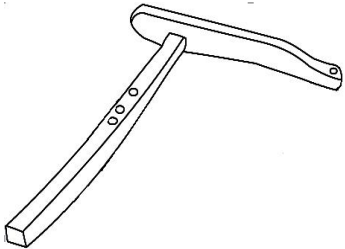

**Weight Capacity:275lbs**

**WARNING:DO NOT STAND ON CHAIR**

D	Left arm		1X
E	Right arm		1X

Hardware

PIECE	DESCRIPTION	PICTURE	QUANTITY
①	Bolt (M8*60MM)		8X
②	Bolt (M8*70MM)		4X
③	Spring Washer		12X
④	Washer		12X
⑤	Allen Key		1X

## PREPARATION

Before beginning assembly of product, make sure all parts are present. Compare parts with package contents list. If any parts are missing or damaged, do not attempt to assemble the product.

Estimated Assembly Time: 20 Minutes.

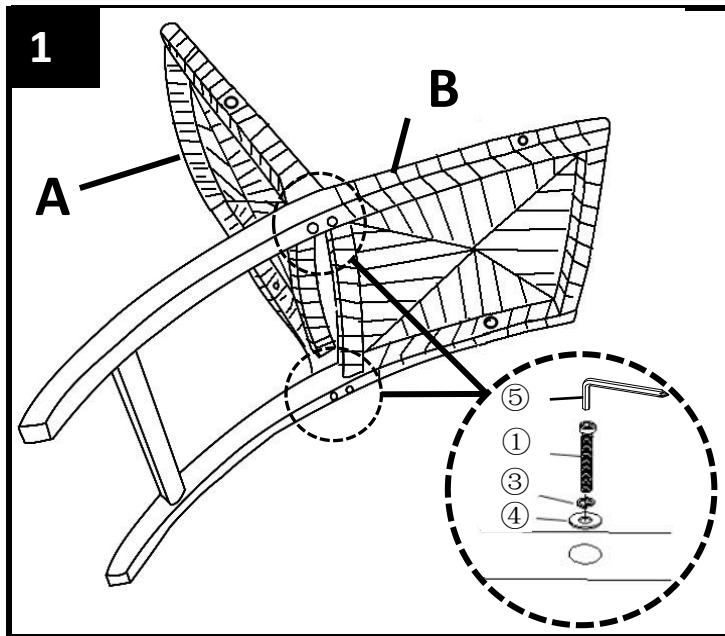

Step1:

Put the Back(A) onto the Seat(B) as shown in the picture.

Attach Back(A) to Seat(B) by using Bolts(①), Spring Washers(③) and Washers(④) with Allen Key(⑤).

**Friendly notice:**

If the mounting positions cannot be aligned well and hinder the installation, then sway the Back(A) lightly when locking the Bolts, this action could help prevent the Bolts from getting stuck and ensure smooth assembly.

**Do not fully tighten the Bolts.**

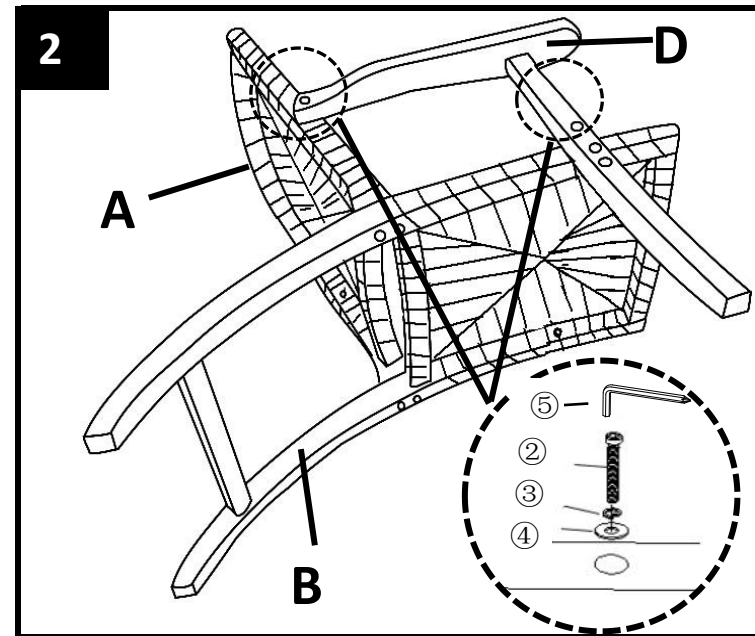

Step2:

Position the Left(D) on the assembled Back(A) and Seat(B) as shown in the picture.

Attach Left leg(D) to Back(A) by using Bolts(②), Spring Washers(③) and Washers(④) with Allen Key(⑤).

**Friendly notice:**

If the mounting positions cannot be aligned well and hinder the installation, then sway the Leg(D) lightly when locking the Bolts, this action could help prevent the Bolts from getting stuck and ensure smooth assembly.

**Do not fully tighten the Bolts.**

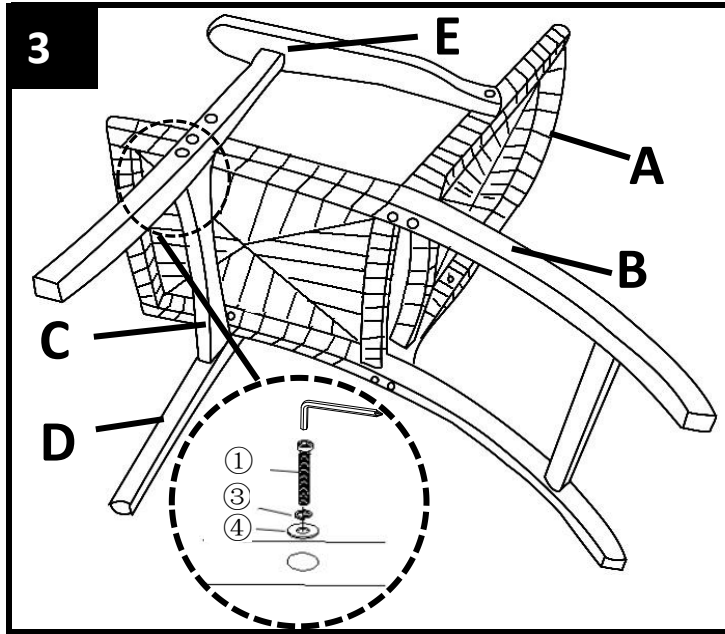

Step3:

Turn the assembled parts over as the photo.

Then put the Right leg(E) onto the Back(A) and Seat (B)

Attach them as step1 to step2.

Put the Seat Rail(C) between the Left leg(D) and Right leg(E)

Attach the Left leg(D) and Right Leg(E) to Seat rail(C) using Bolts(①), Spring Washers(③) and Washers(④) with Allen Key(⑤).

Finally, tighten the Bolts fully in a sequential manner.