

**ASSEMBLY INSTRUCTIONS / INSTRUCTIONS
D'ASSEMBLAGE / INSTRUCTIVO DE ARMADO**

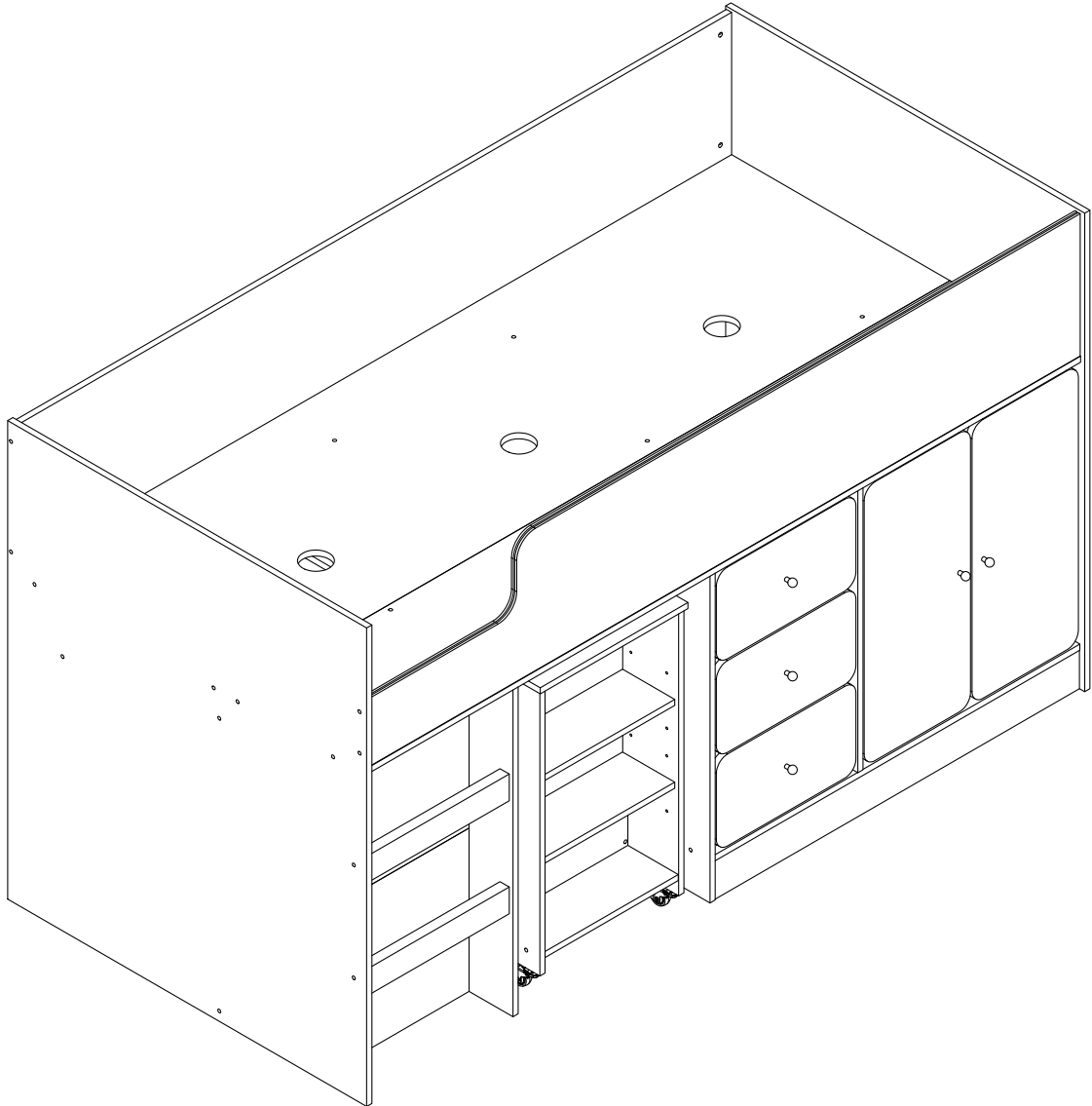

1-01068

IMPORTANT : READ CAREFULLY - RETAIN FOR FUTURE REFERENCE

Top Tips before you start!

1. Please check that all parts are present before you start the assembly of your furniture, as once assembled, the furniture is exempt from our home approval policy.
2. For ease and speed of assembly, we recommend that before you commence each step of the assembly, that you identify all the parts required for that step.
3. For larger items, please ensure that you have sufficient space and people (as indicated on Page 1) to assemble your product safely.
4. We recommend that, where possible, all items are assembled near to the area in which they will be placed in use, to avoid moving the product unnecessarily once assembled.
5. For the protection of your furniture, particularly items of high gloss finish, we recommend that the product is placed on a protected surface during assembly to prevent any damage.
6. During assembly please take care not to over-tighten any fittings, as this may damage the product.

CARE AND MAINTENANCE OF YOUR FURNITURE

- Please periodically check all fittings and re-tighten as necessary.
- Please do not jump on your furniture.
- To clean your item, please use a damp cloth and wipe clean.
- Routinely check that the upper safety rail and ladder attachment is secure and tighten any fittings using the appropriate tools.
- This product is tested to meet BS EN 747-1:2024 standards. The maximum upper safe load is 70kgs or 155lbs or 11 stones.
- Please ensure that the mattress height does not go past the permanent mark on the post / upper safety barrier.
- The size of mattress to be use with this child's be is 920mm and 1910mm x 160mm.
- **WARNING!** Do not use the bunk bed/high bed if any structural part is broken or missing.
- **WARNING!** High beds and the upper bed of bunk beds are not suitable for children under six (6) years due to risk of injury from falls.
- **WARNING!** Bunk beds and high beds can present a serious risk of injury from strangulation if not used correctly. Never attach or hang items to any part of the bunk bed that are not designed to be used with the bed, for example, but not limited to ropes, strings, cords, hooks, belts and bags.
- **WARNING!** Children can become trapped between the bed and the walls, a roof pitch, the ceiling, adjoining pieces of furniture (e.g. cupboards) and the like. To avoid risk of serious injury the distance between the top barrier and the adjoining structure shall not exceed 75mm or shall be more than 230mm.
- Always follow the manufacturer's instruction.
- The ventilation of the room is necessary in order to keep the humidity low and to prevent mould in and around the bed.

WARNING

TO HELP PREVENT SERIOUS OR FATAL INJURIES FROM ENTRAPMENT OR FALLS:

Safety Warnings:

1. Always use the recommended size mattress or mattress support, or both, to help prevent the likelihood of entrapment or falls.
2. Ensure thickness of mattress does not exceed 6”(160mm).
3. Surface of mattress must be at least (160mm) below the upper edge of guardrails.
4. Prohibit more than one person on upper bunk.
5. Always use the ladder for entering and leaving the upper bunk.
6. Do not use substitute parts. Contact manufacturer or dealers for replacement parts.
7. Use of a night light may provide added safety precaution for a child using the upper bunk.
8. Always use guardrails on both long sides of the upper bunk. If the bunk bed will be placed next to the wall, the guardrail that runs the full length of the bed should be placed against the wall to prevent entrapment between the bed and wall.
9. The use of water or sleep floatation mattress is prohibited.
10. Keep these instructions for future reference.

STRANGULATION HAZARD

Never attach or hang items to any part of the bunk bed that are not designed for use with the bed; for example, but not limited to hooks, belts, and jump ropes.

THINGS TO REMEMBER FOR ASSEMBLY
CHOSSES À SE SOUVENIR POUR UNE ASSEMBLEE
COSAS PARA RECORDAR EN UNA ASAMBLEA

MINIFIX BOLT
BOULON MINIFIX
PERNO MINIFIX

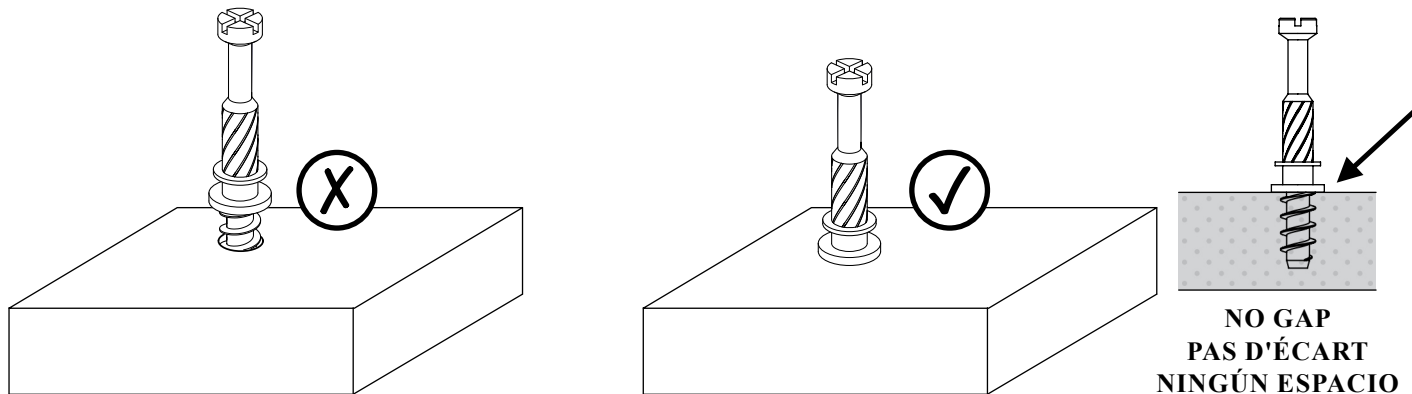

MINIFIX CAM
CAMÉRA MINIFIX
CÁMARA MINIFIX

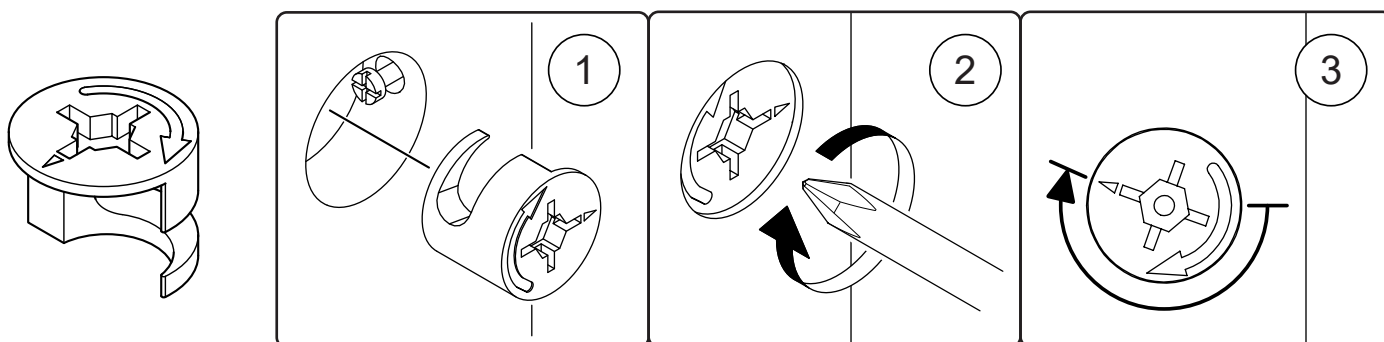

WOOD DOWEL
CHEVILLE BOIS
PASADOR DE MADERA

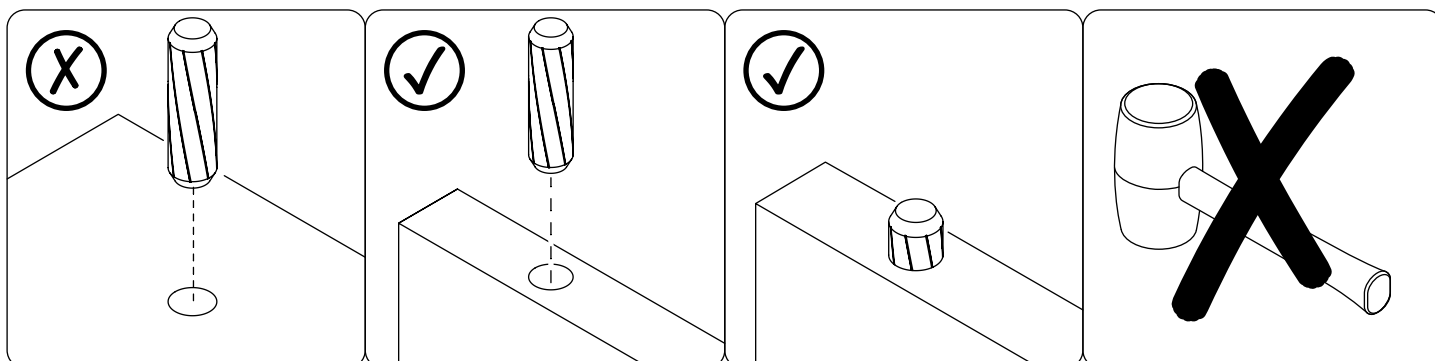

SPECIAL TIPS FOR FITTING DRAWER CONSEJOS ESPECIALES PARA EL MONTAJE DEL CAJÓN CONSEILS SPÉCIAUX POUR LE MONTAGE DU TIROIR

DRAWER SLIDE - CABINET MEMBER - LEFT

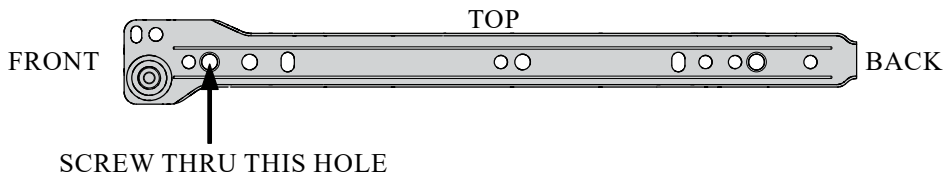

DRAWER SLIDE - CABINET MEMBER - RIGHT

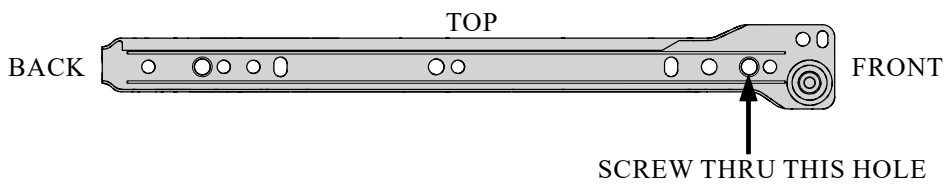

DRAWER SLIDE - DRAWER MEMBER - LEFT AND RIGHT

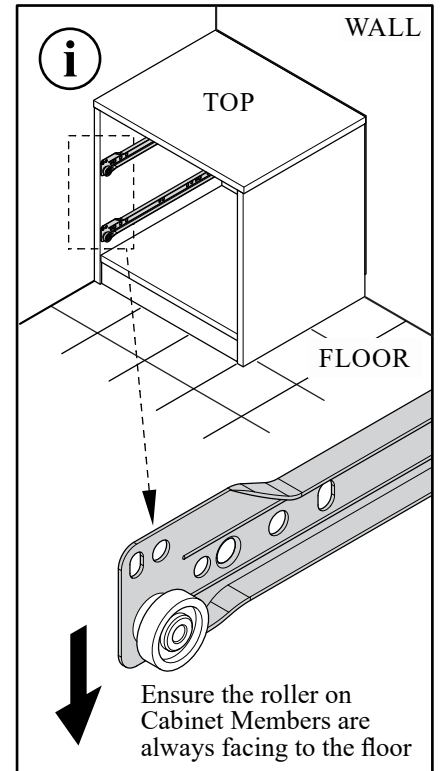
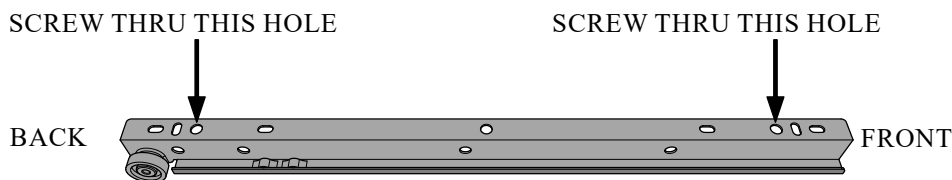
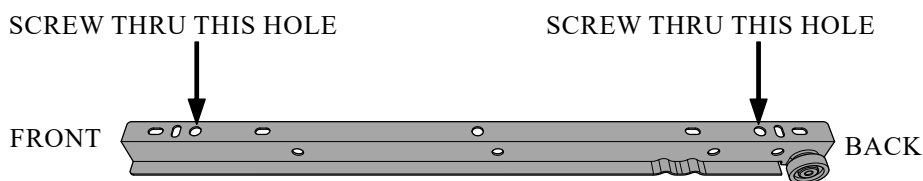

Ensure the drawer members are fully pushed to drawer front

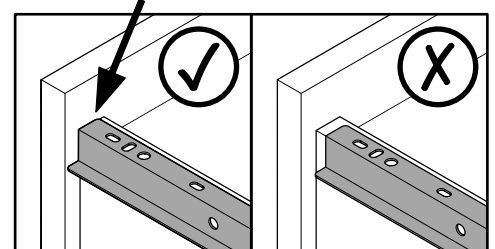



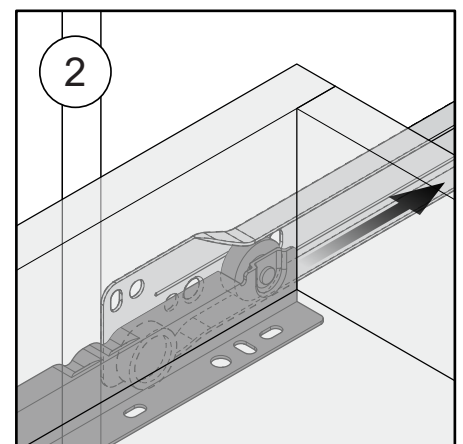
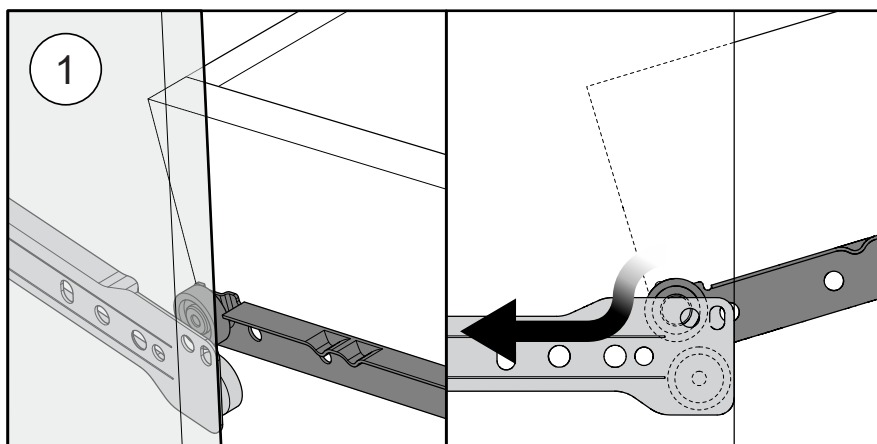



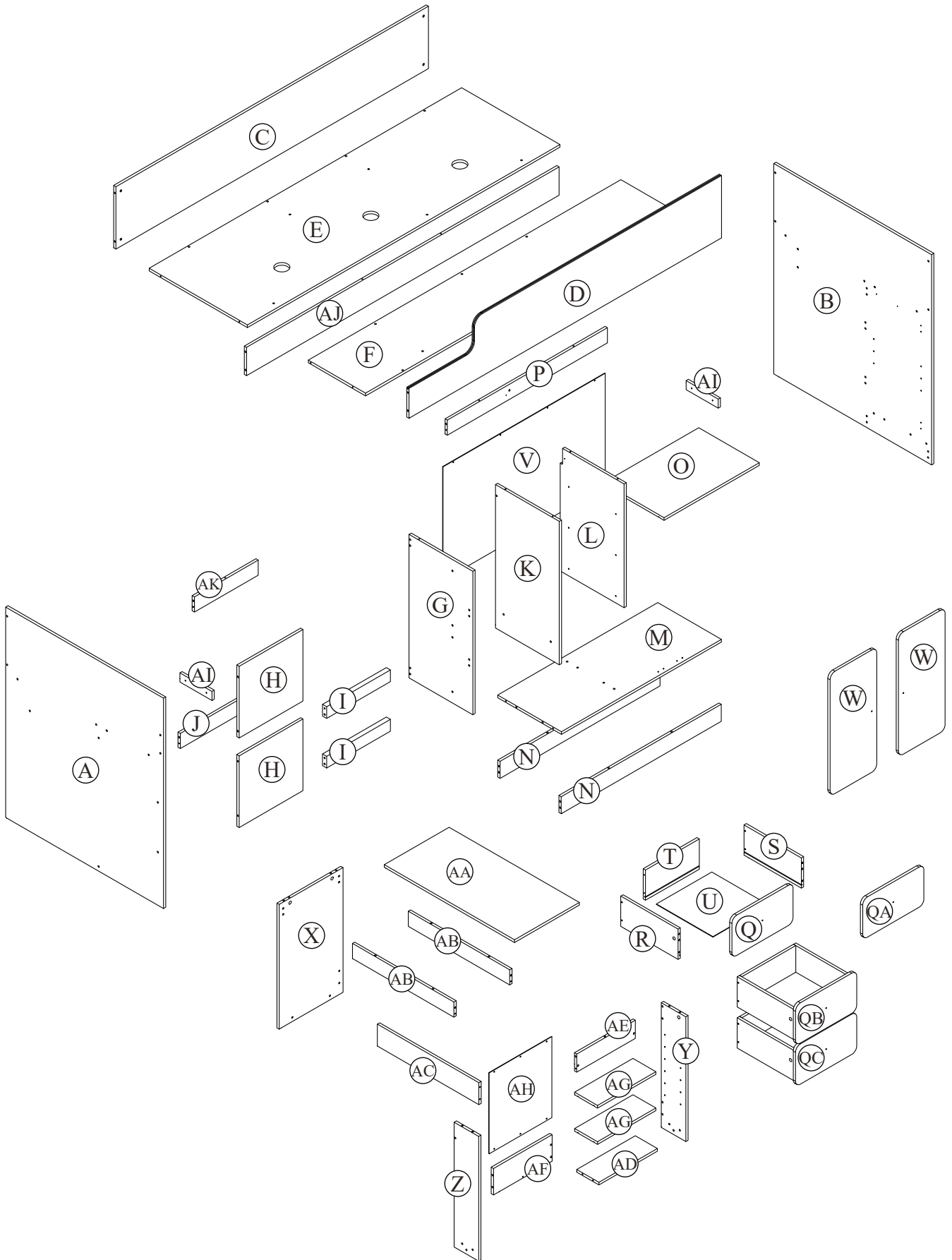







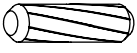









INSTALL DRAWER TO CABINET INSTALE EL CAJÓN AL GABINETE INSTALLER LE TIROIR SUR L'ARMOIRE

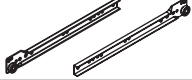

PARTS IDENTIFICATION
IDENTIFICATION DES PIÈCES
IDENTIFICACIÓN DE LAS PARTES



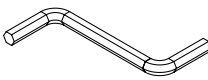

HARDWARE QUINCAILLERIE / HERRAJE

(A)	Screw M6 x 55mm  14 units	(B)	Unita M6.3 x 40mm  53 units	(C)	Screw M4 x 38mm  12 units
(D)	Minifix Bolt  11 units	(E)	Dowel M8 x 30mm  70 + 2 units	(F)	Screw M6 x 25mm  4 units
(G)	Screw M4 x 25mm  4 units	(H)	Screw M4 x 20mm  5 units	(I)	Screw #10 x 1/2"  16 units
(J)	Screw M3.5 x 15mm  28 + 2 units	(K)	Screw M6 x 8mm  12 units	(L)	Minifix Cam (15/9.5)  11 units
(M)	Nail Pin 3/4"  14 units	(N)	PVC L Bracket  3 units	(O)	Barrel Nut  14 units
(P)	Hinge 7/8"  4 units	(Q)	Door Stopper  4 units	(R)	Cabinet Member 14"  3 sets
(S)	Drawer Member 14"  3 sets	(T)	Hex Nut  4 units	(U)	Handle  5 units
(V)	Shelf Support  12 units	(W)	MDF Support  2 units	(X)	Castor without Stopper  2 units
(Y)	Castor with Stopper  2 units	(Z)	Allen Key Z M4  1 unit		

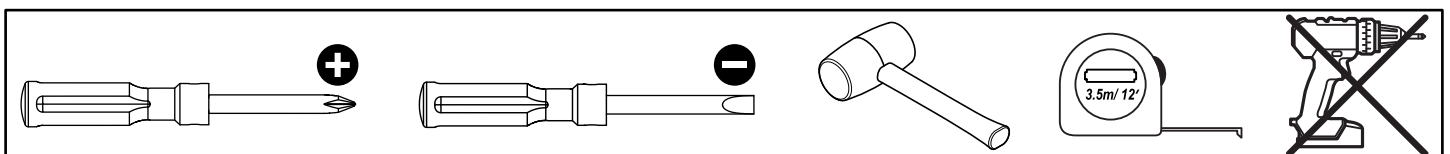
**TOOLS NOT INCLUDED
OUTILS PAS INCLUS / HERRAMIENTAS NO INCLUIDAS**



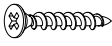

STEP 1

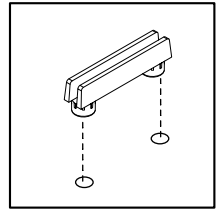
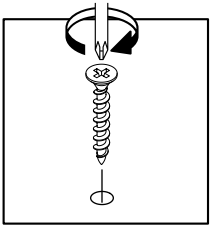
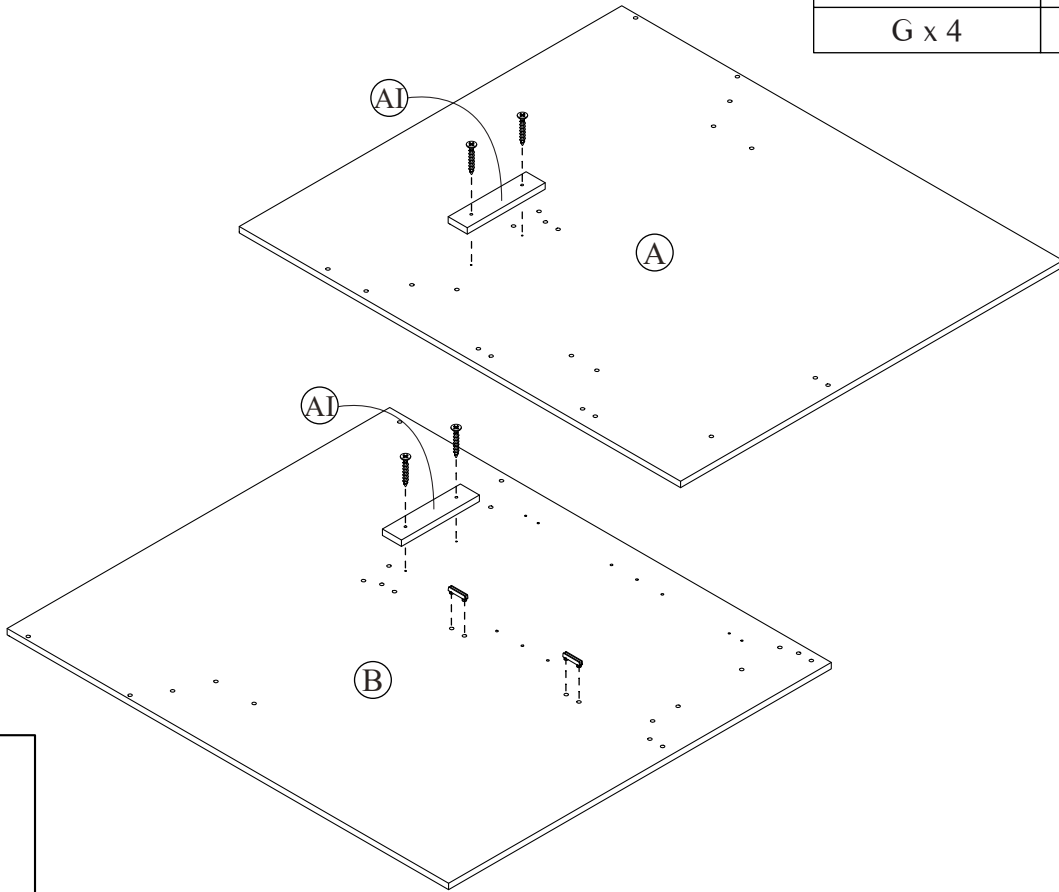
	
G x 4	W x 2



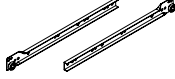

STEP 2

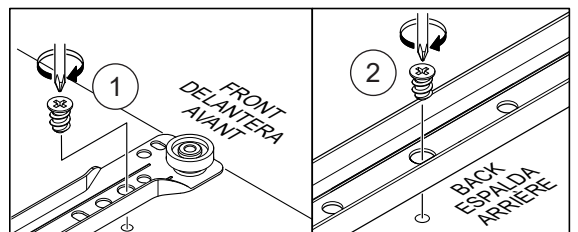
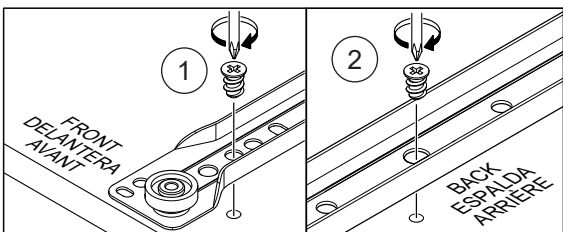
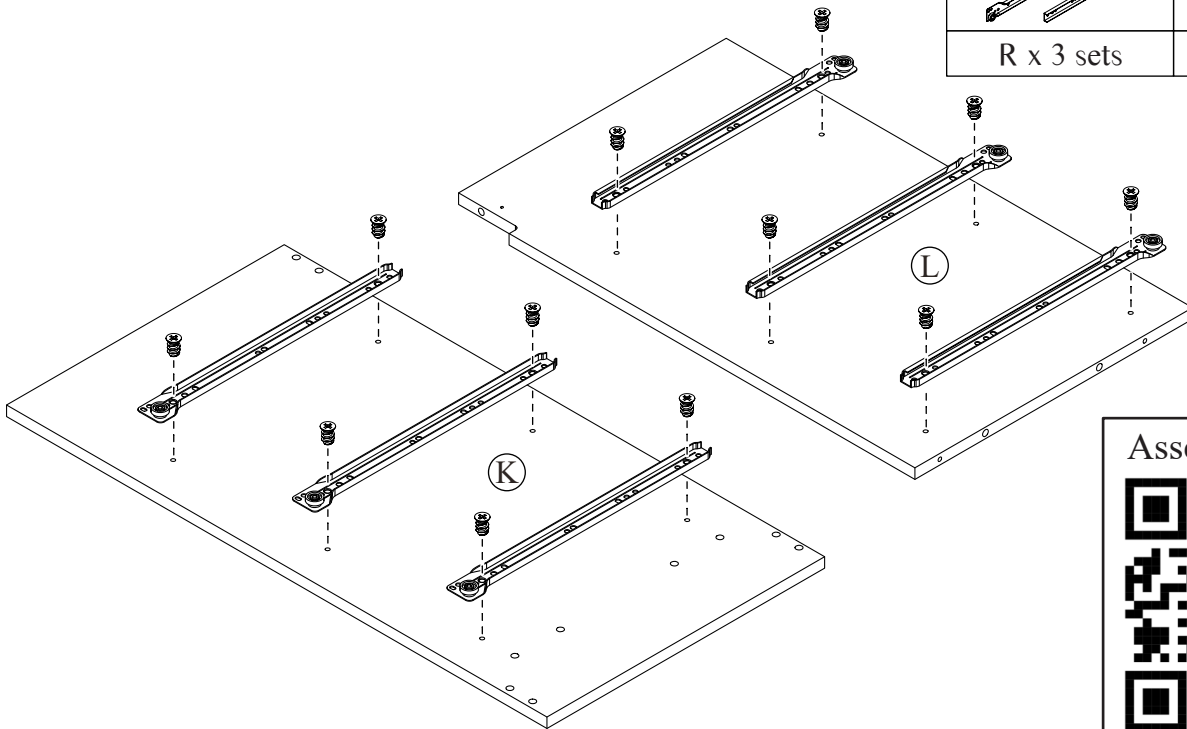
	
R x 3 sets	K x 12



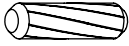

STEP 3

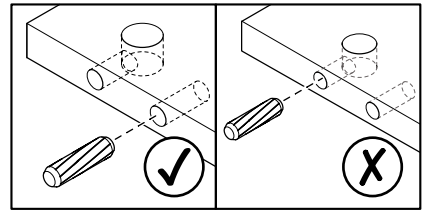
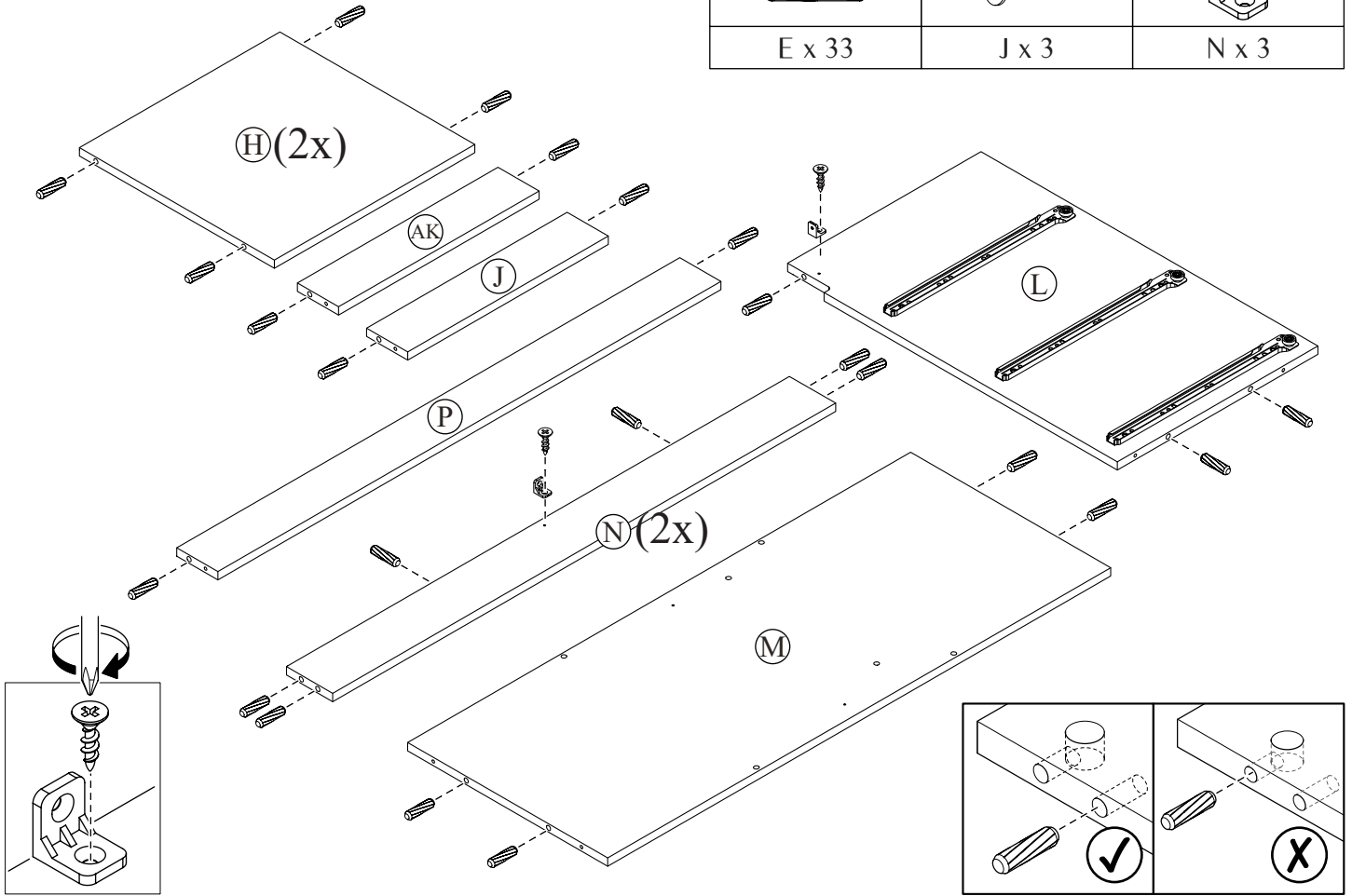
		
E x 33	J x 3	N x 3



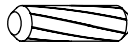

STEP 4

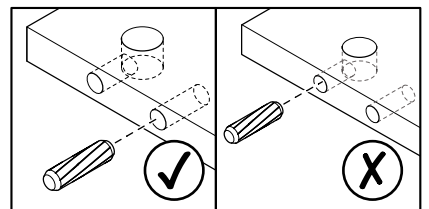
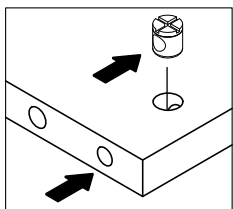
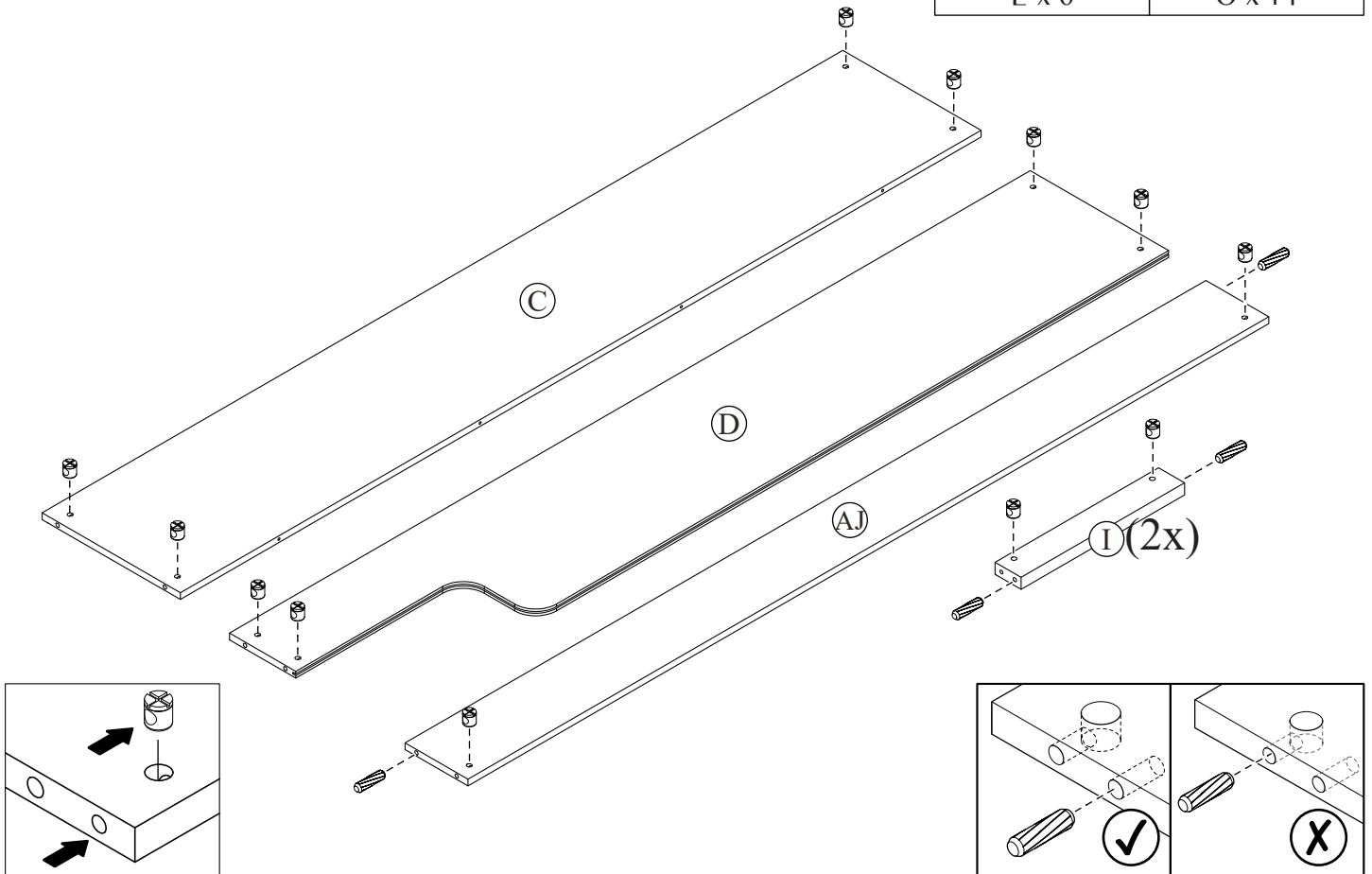
	
E x 6	O x 14



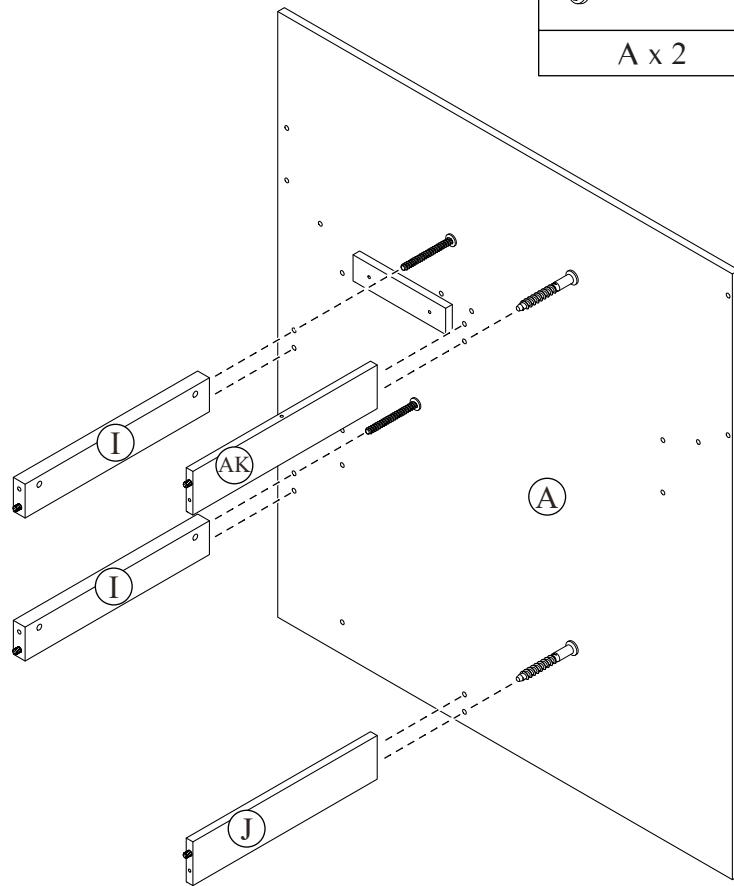
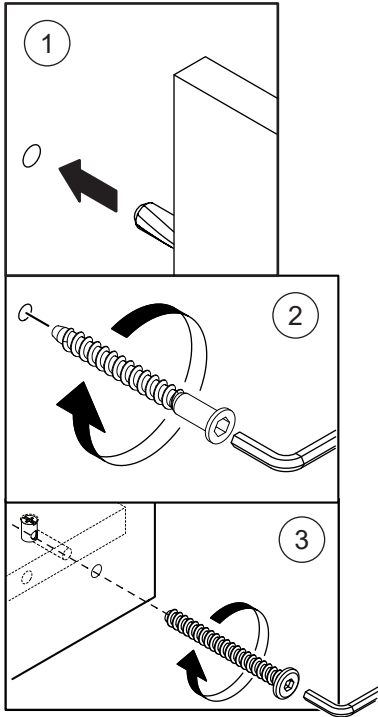

STEP 5

	
A x 2	B x 2



STEP 6

	
A x 2	B x 2

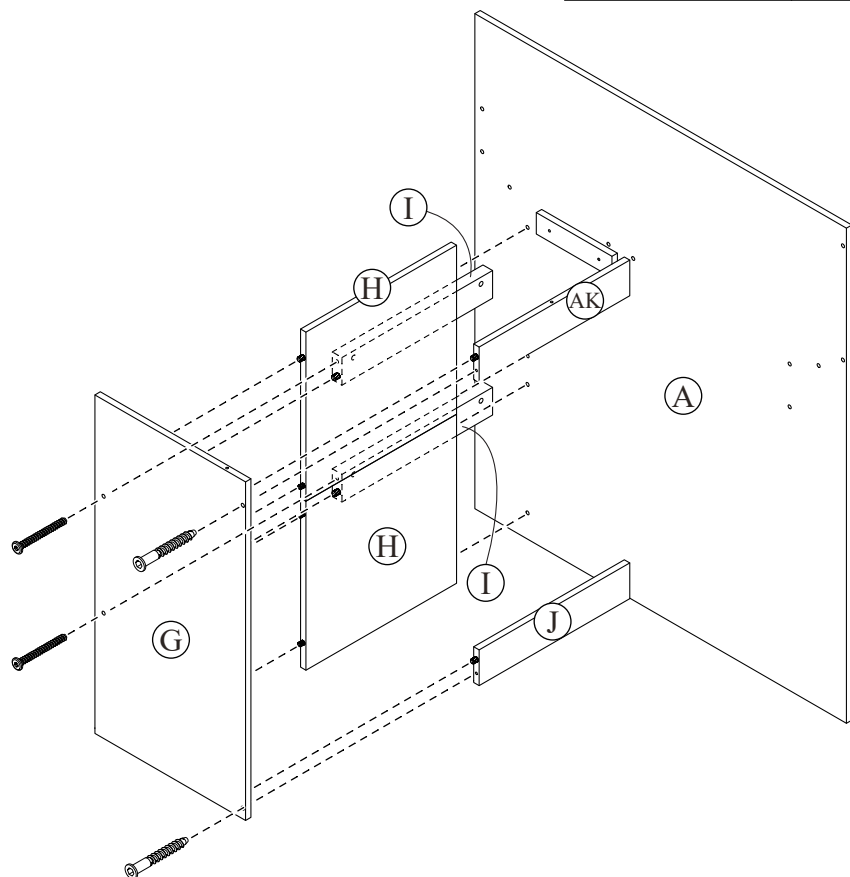
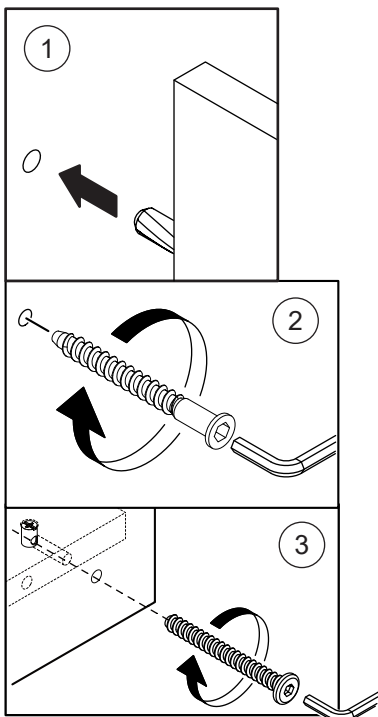

STEP 7

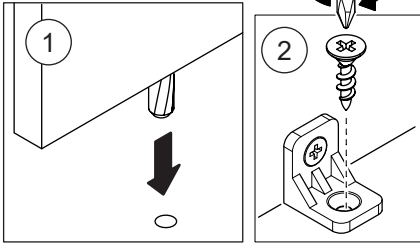
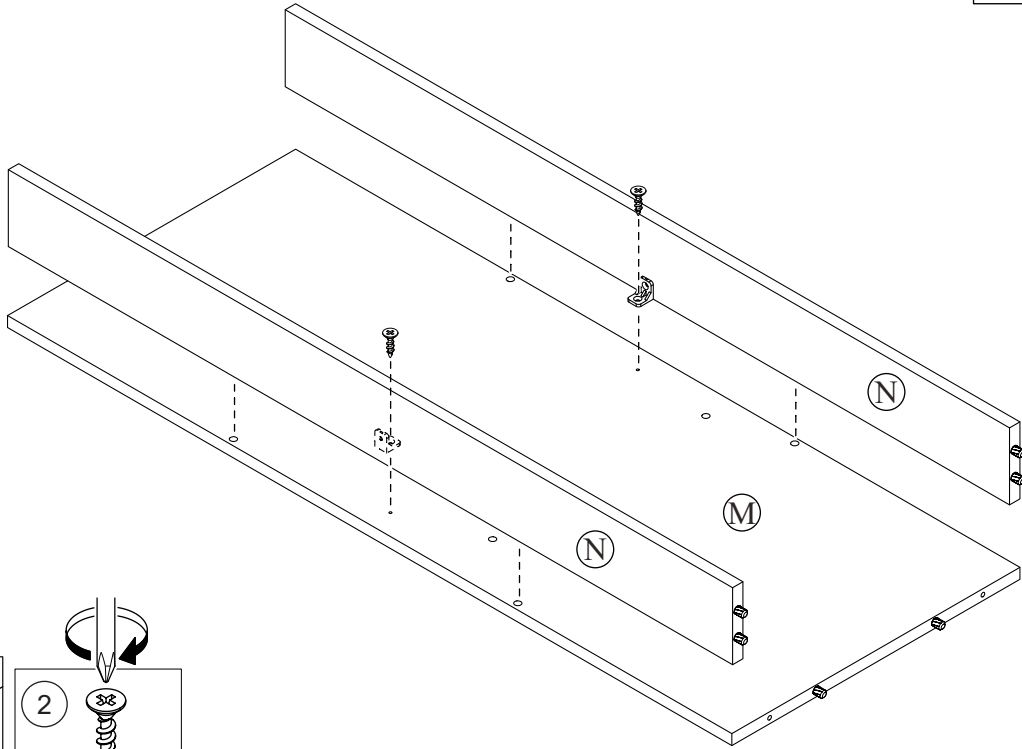
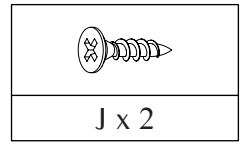

STEP 8

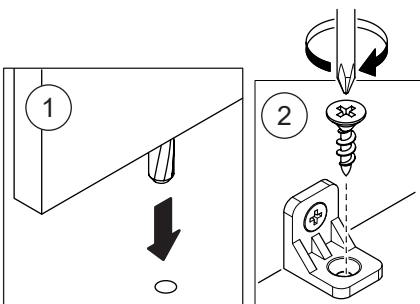
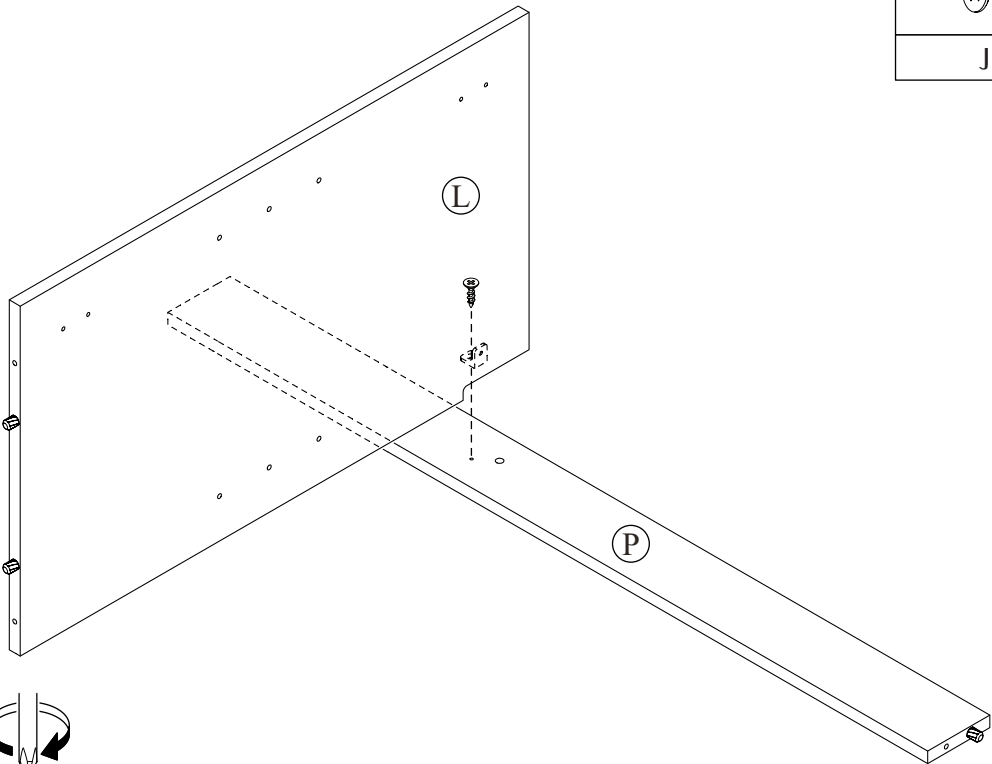
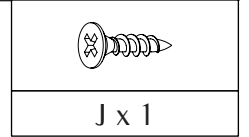

STEP 9

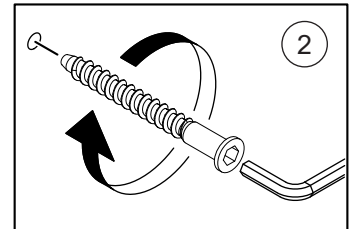
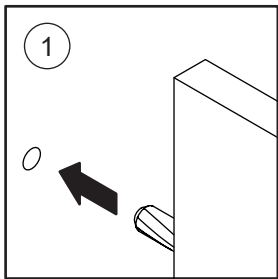
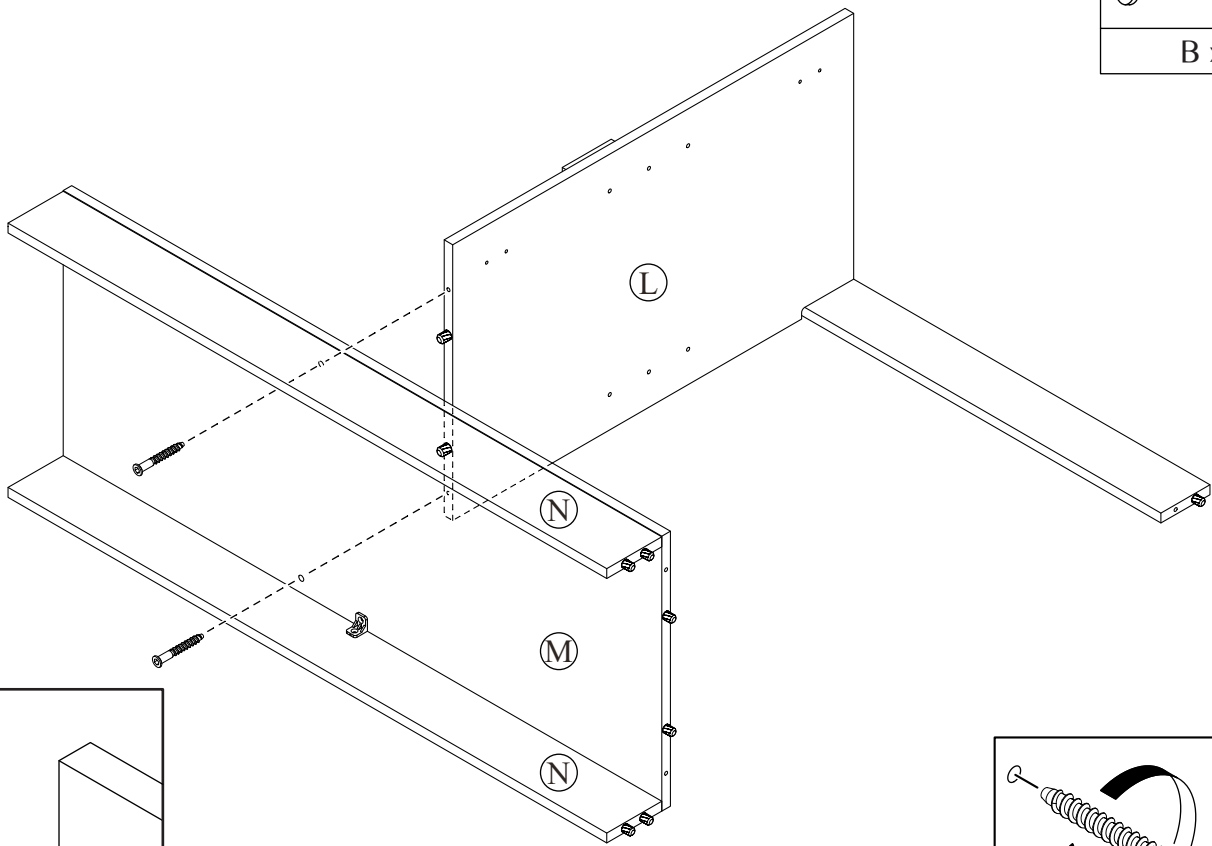
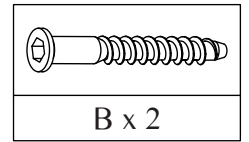

STEP 10

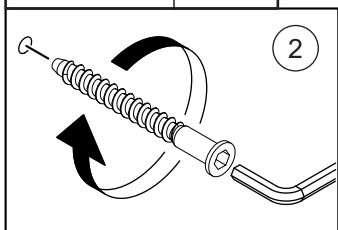
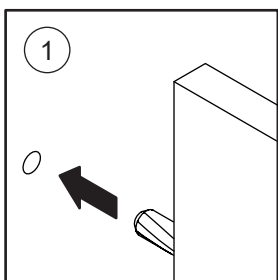
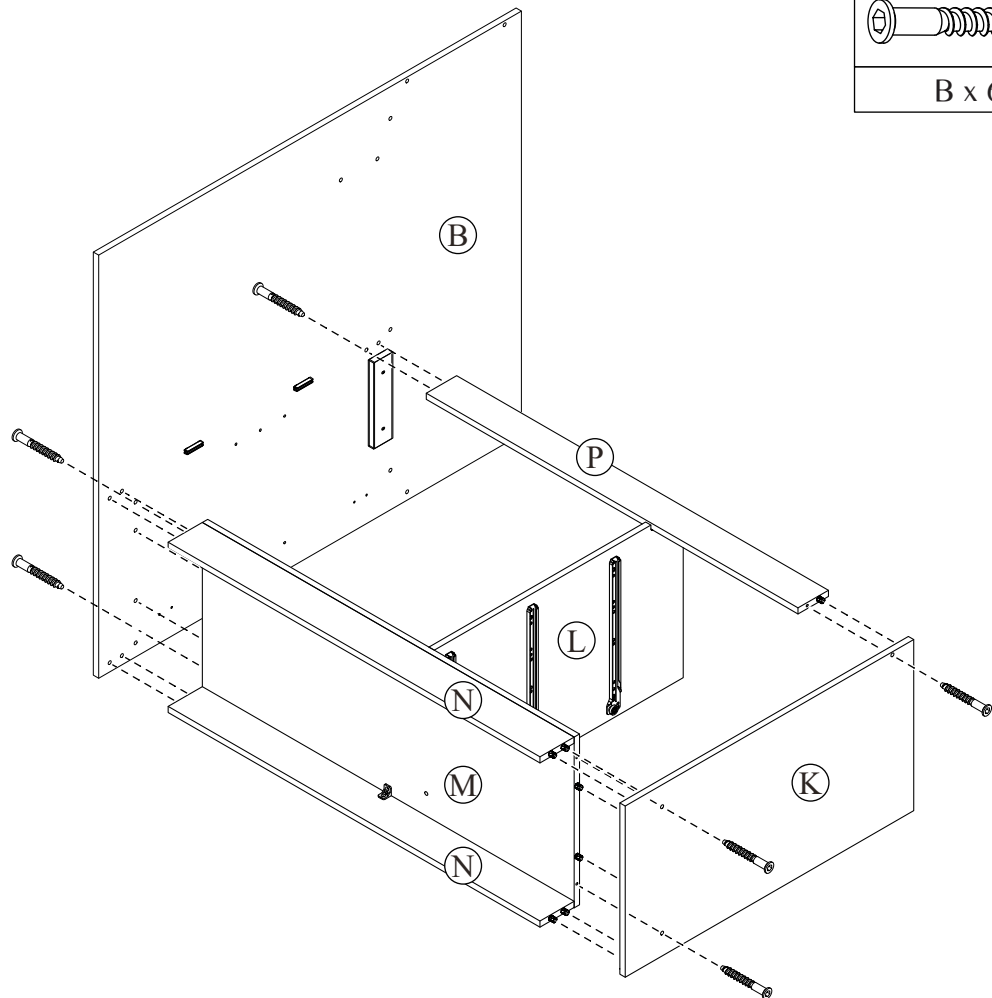
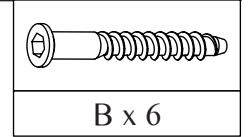

STEP 11

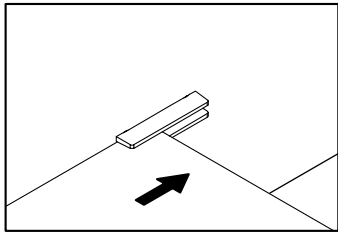
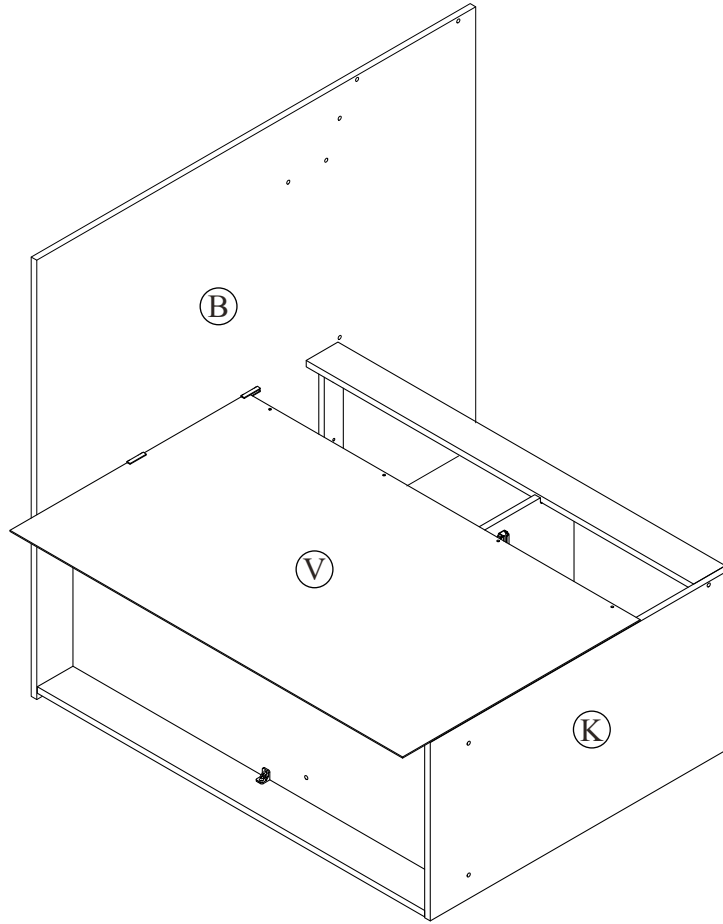

STEP 12

	
J x 4	M x 10

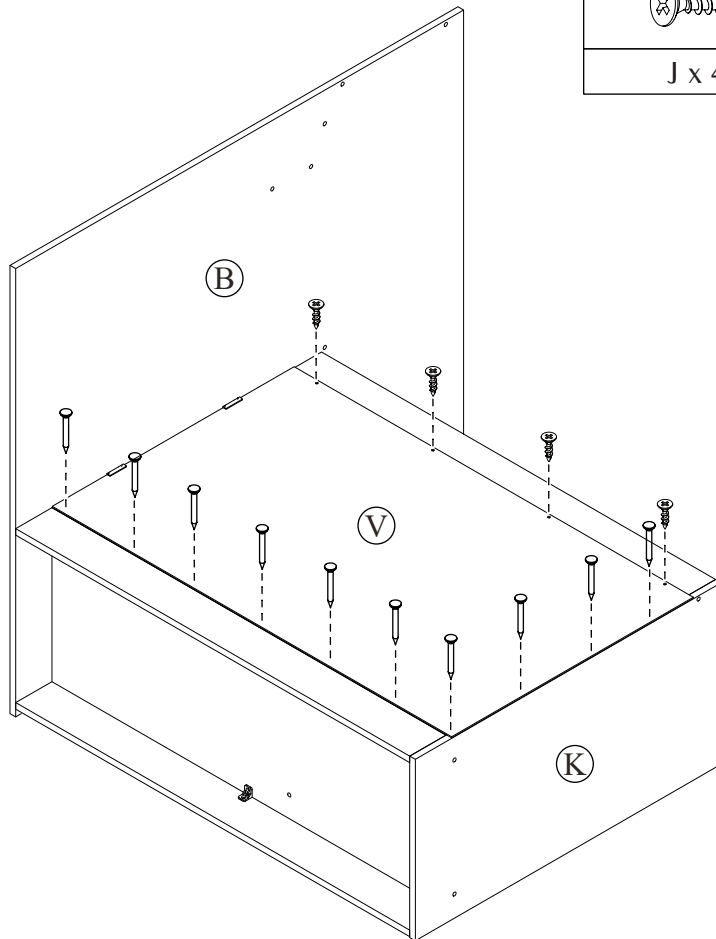
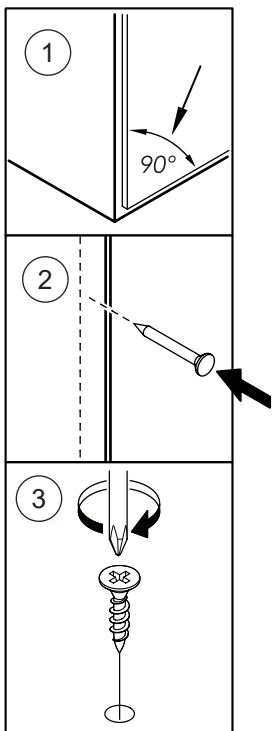

STEP 13

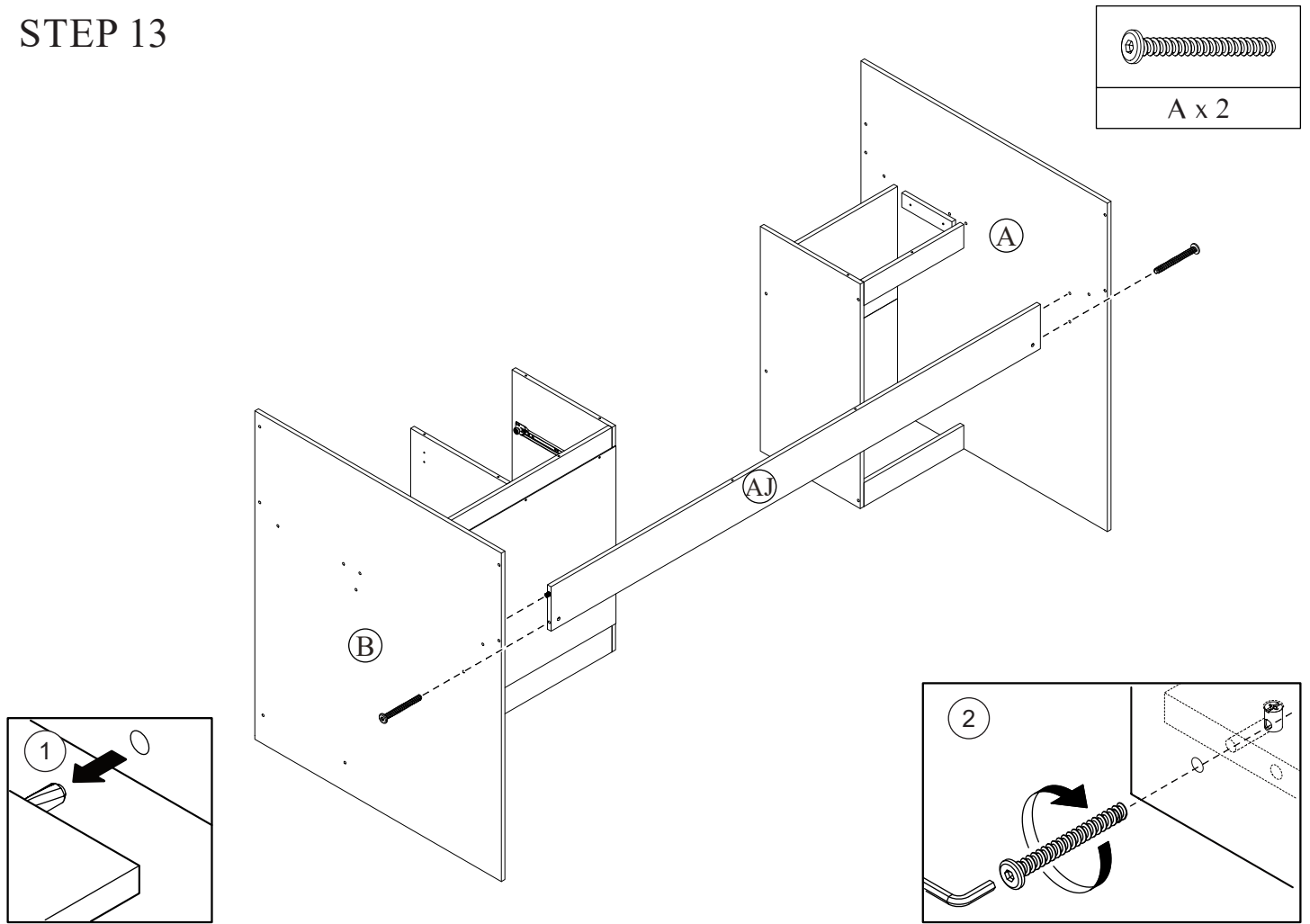

STEP 14

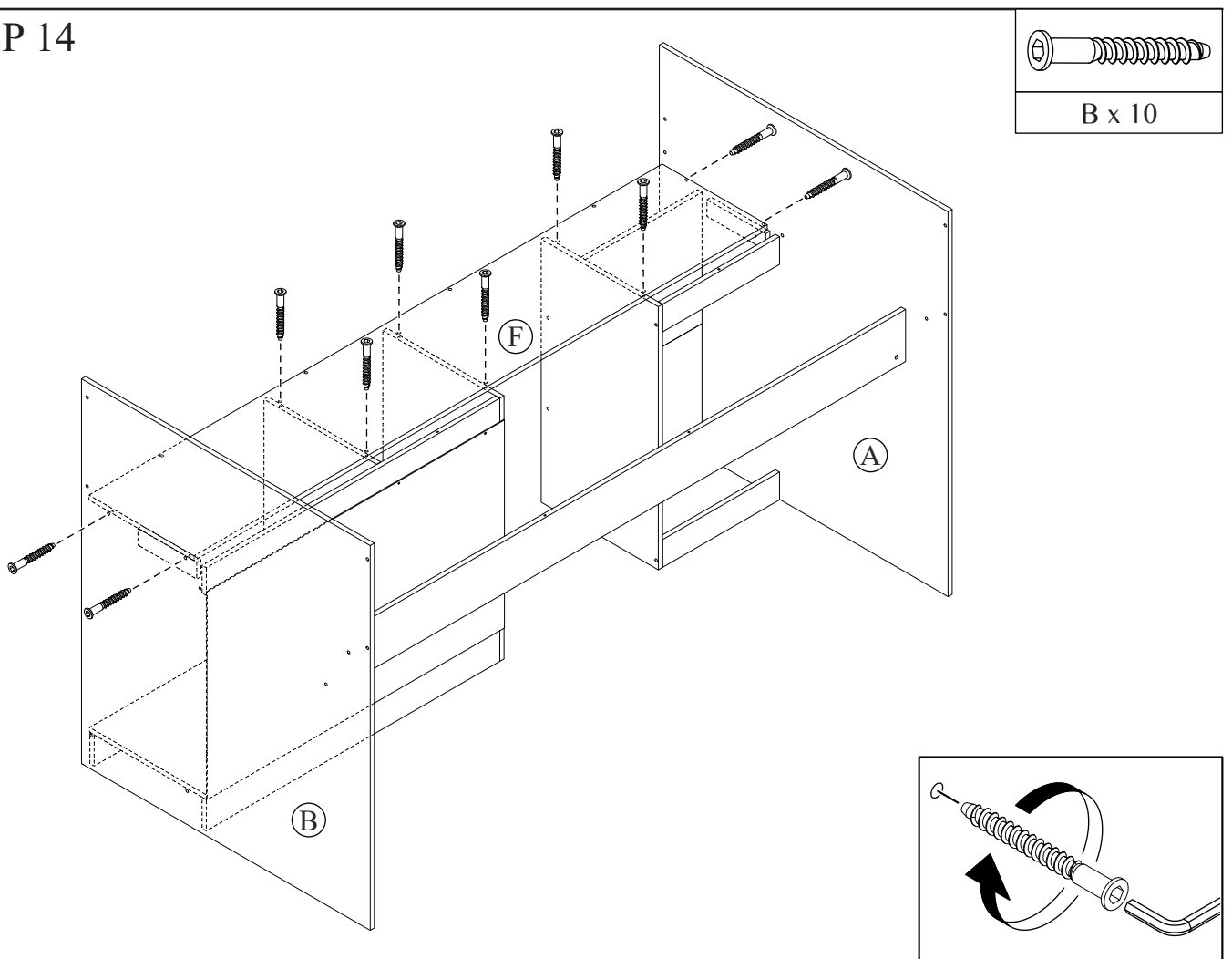

STEP 15

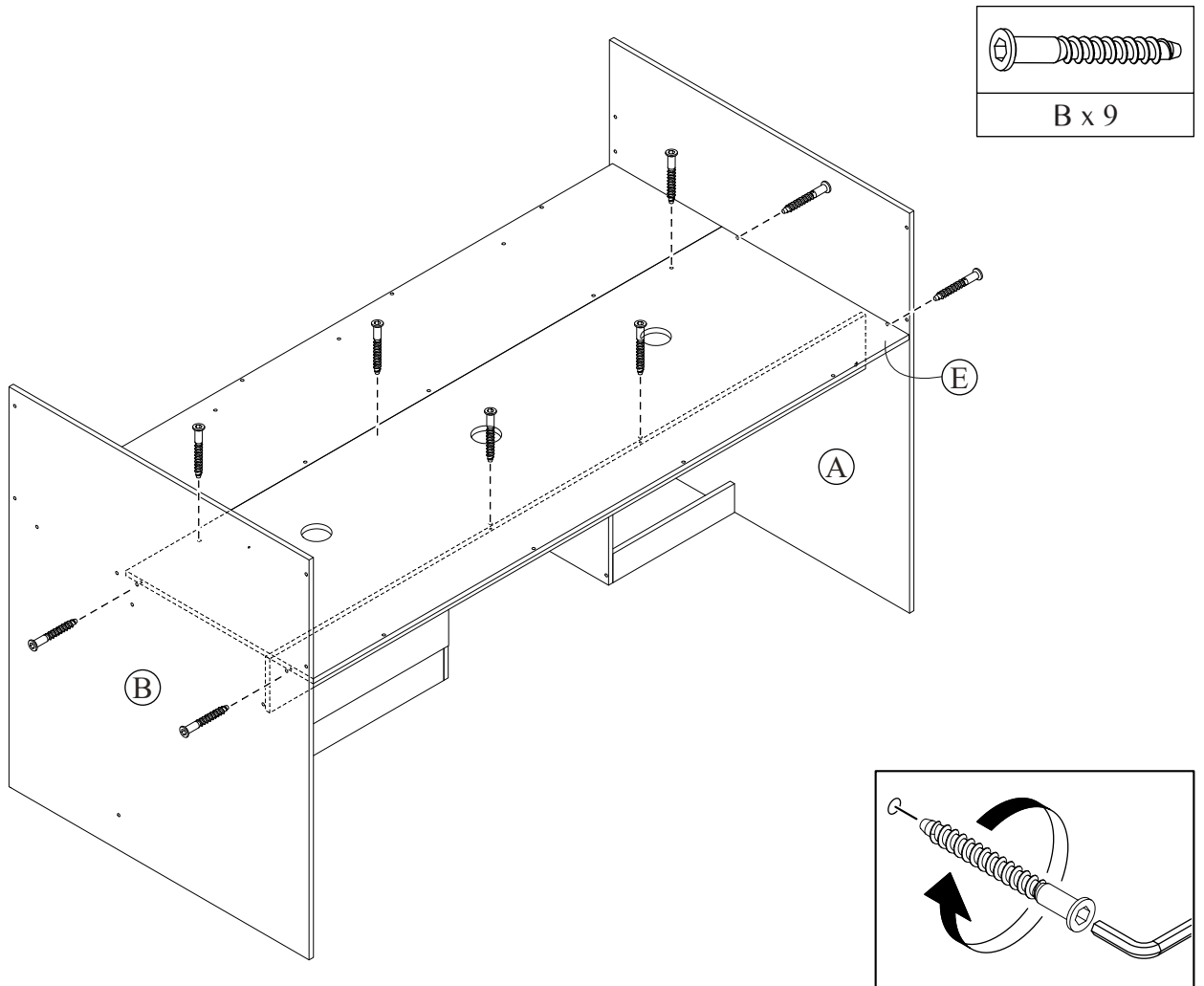

STEP 16

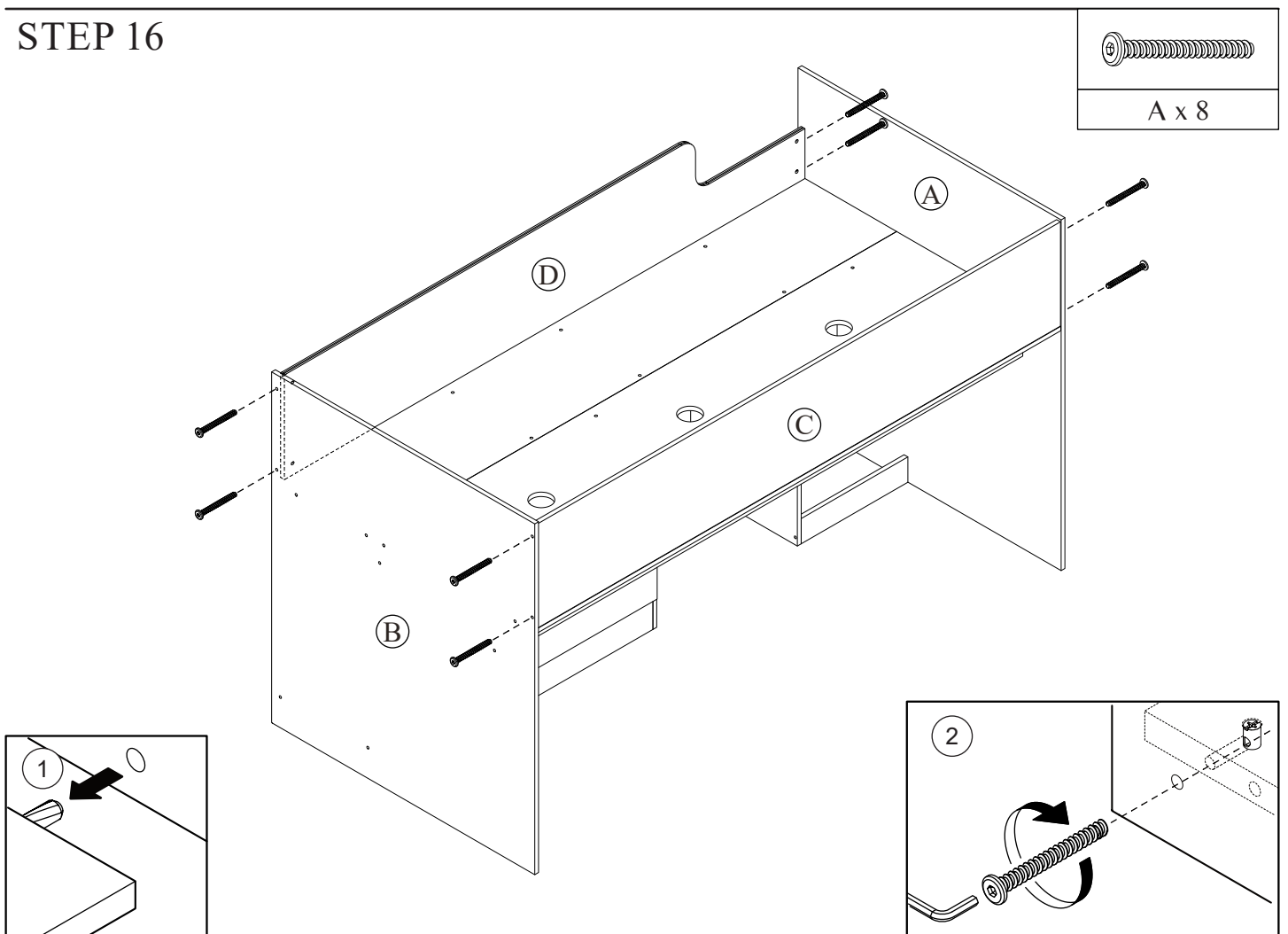

STEP 17

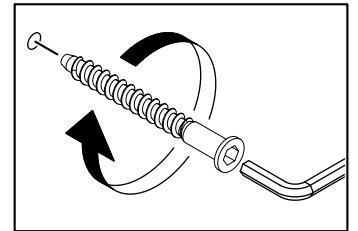
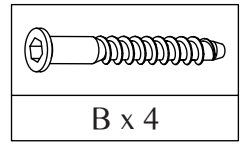
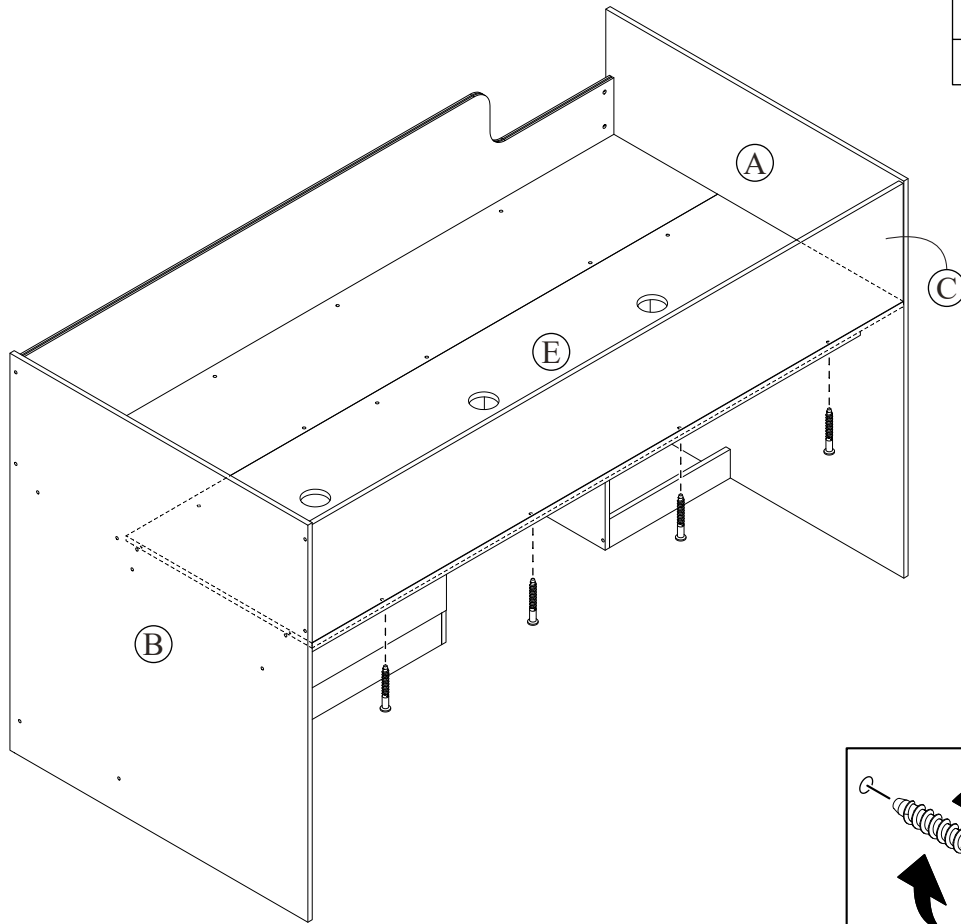

STEP 18

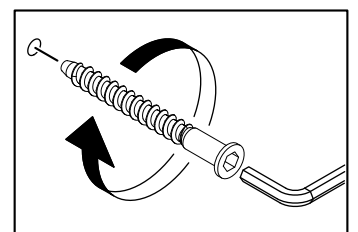
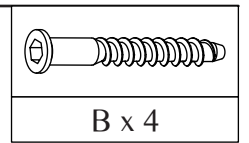
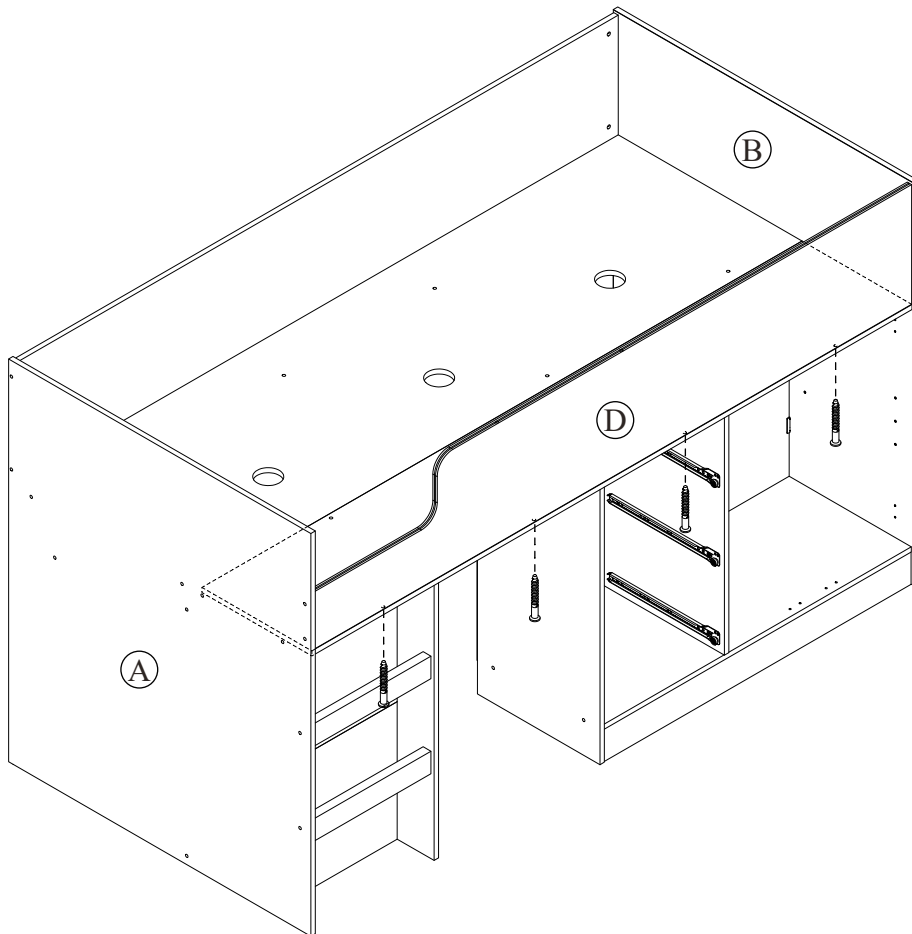

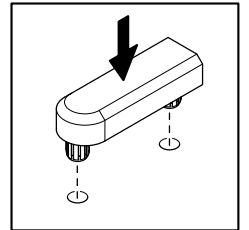
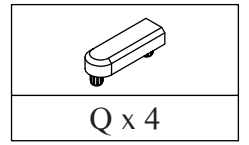
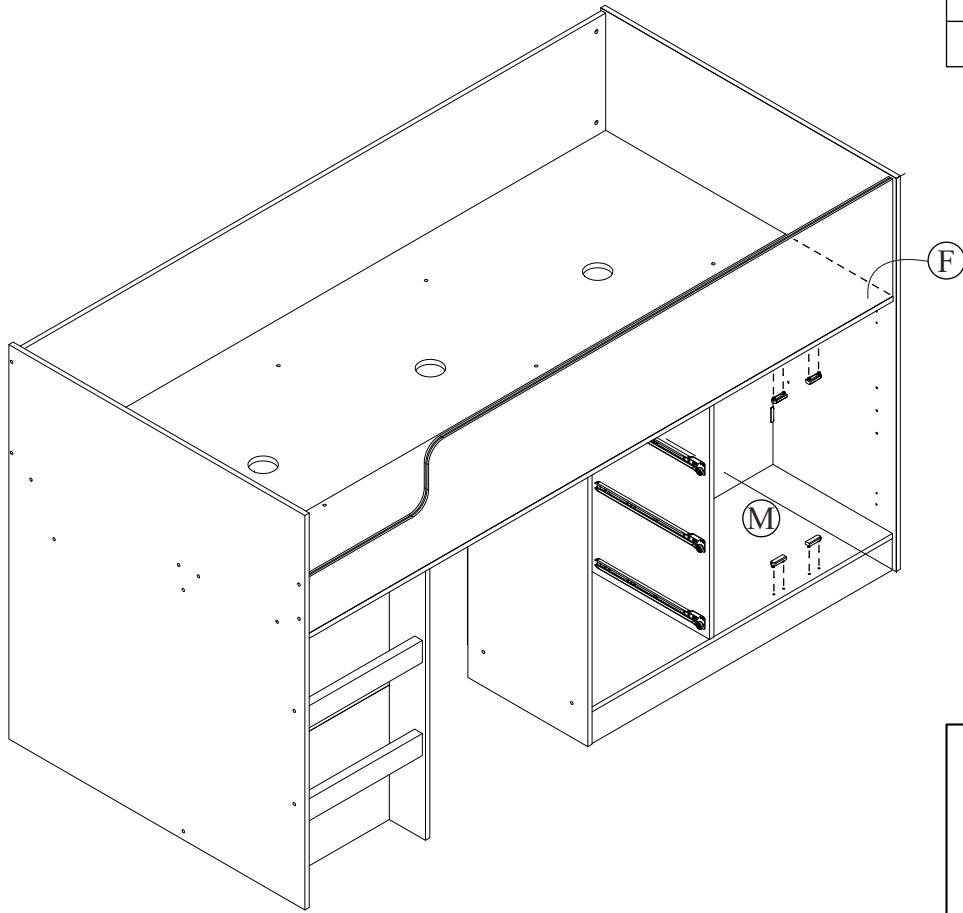

STEP 19

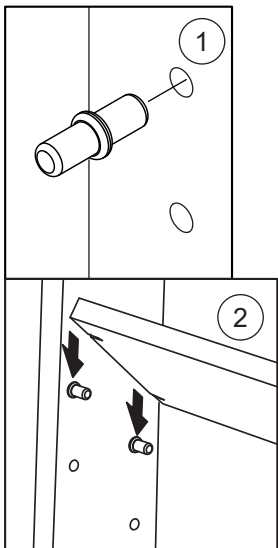
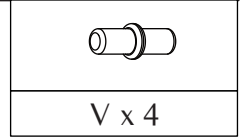
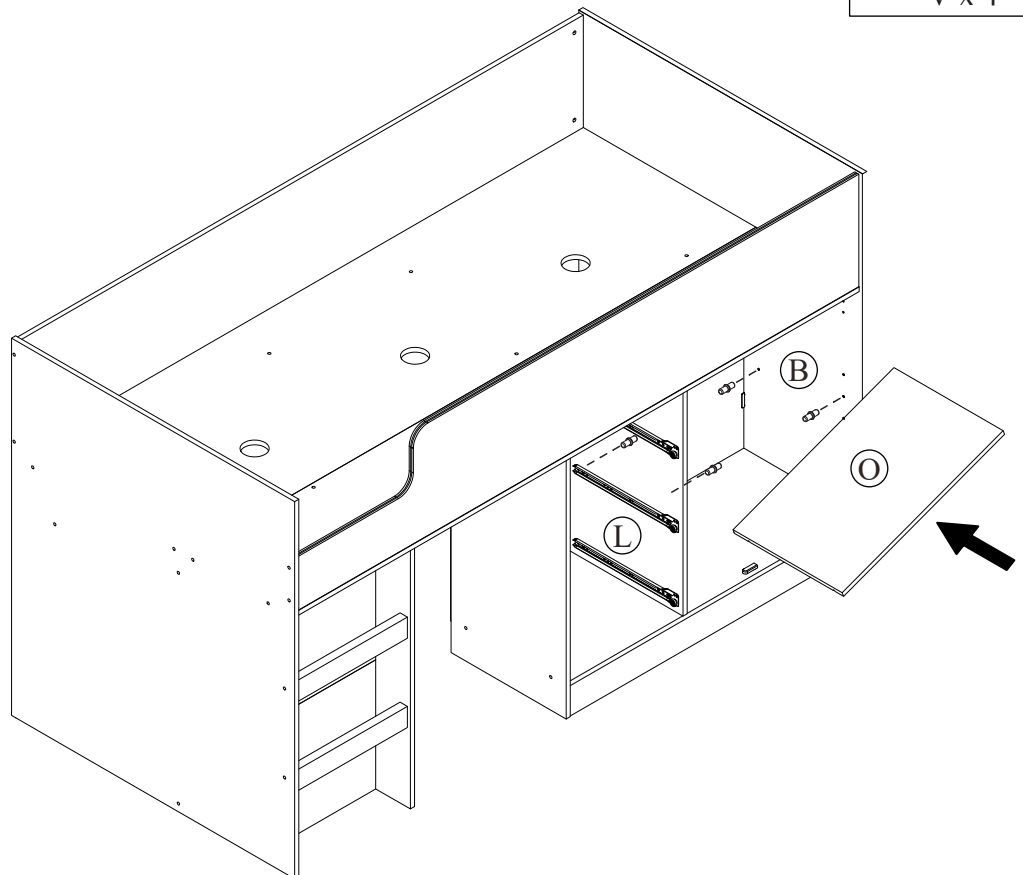

STEP 20



STEP 21

	
P x 4	l x 8

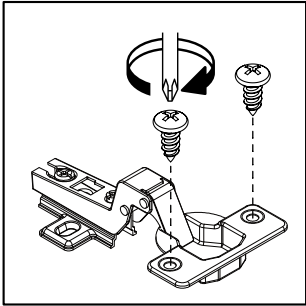
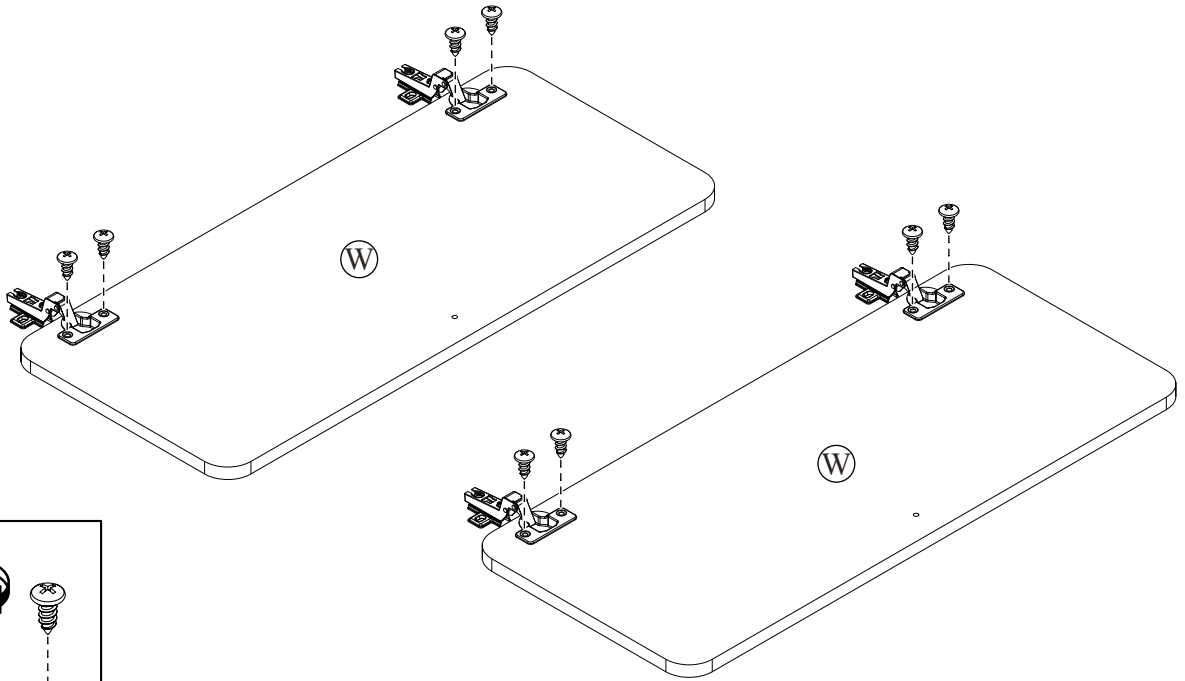

STEP 22

l x 8

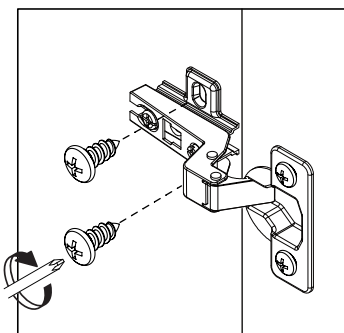
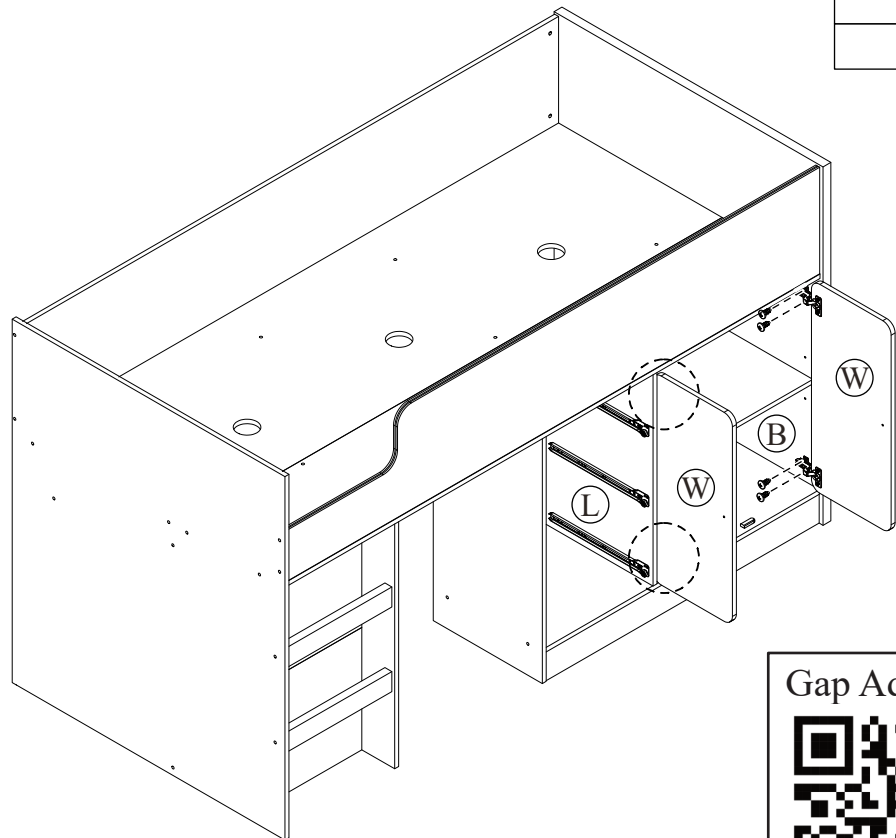

Gap Adjustment



SPECIAL TIPS FOR DOOR ALIGNMENT

CONSEJOS ESPECIALES PARA LA ALINEACIÓN DE PUERTAS

CONSEILS SPÉCIAUX POUR L'ALIGNEMENT DES PORTES

- A. Lateral adjustment (Moving door left-right) by screw adjusting
 Ajuste lateral (Puerta móvil de izquierda a derecha) mediante tornillo de ajuste
 Réglage latéral (porte mobile gauche-droite) par réglage à vis

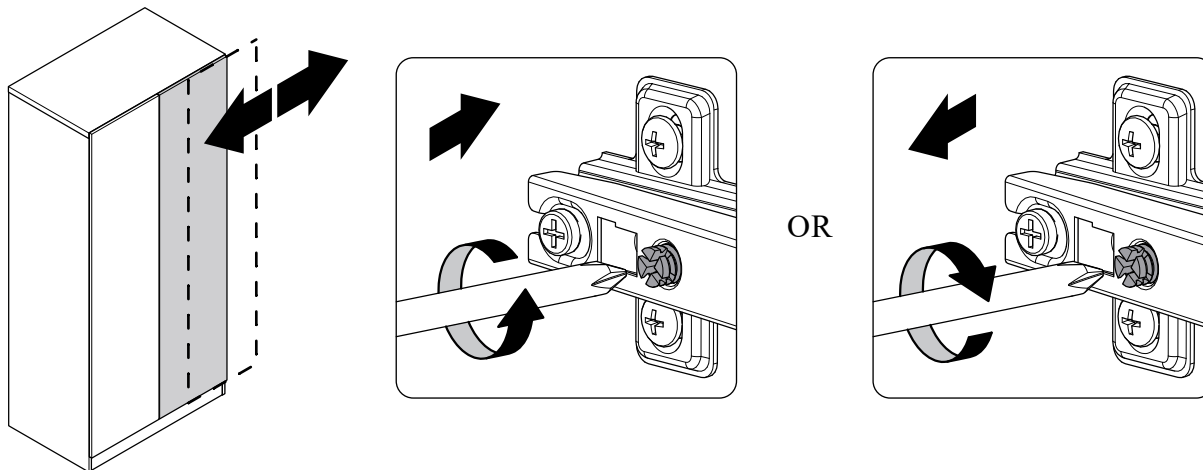

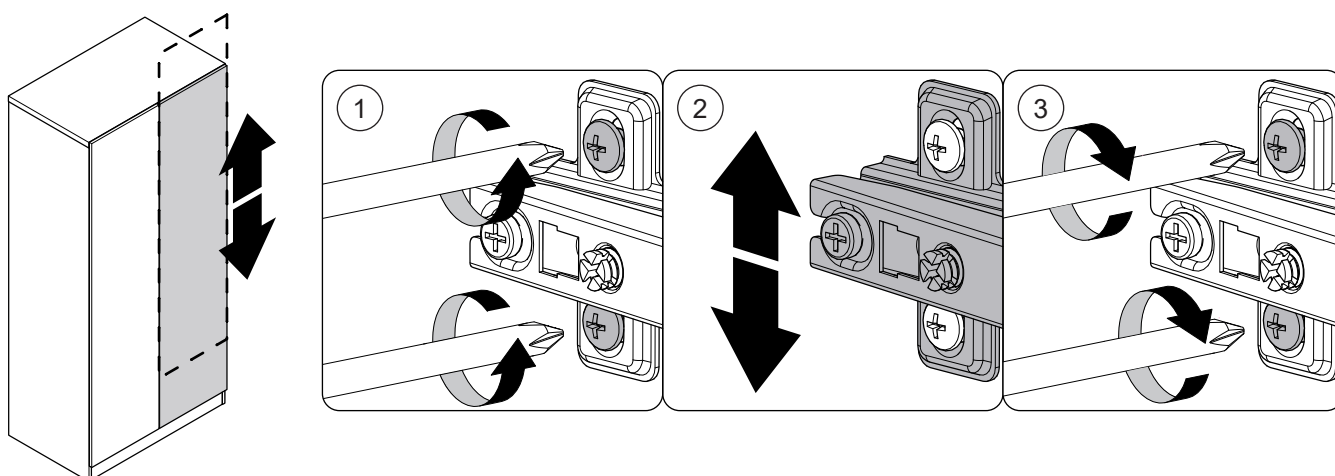

- B. Vertical adjustment (Moving door up-down) via the slot on the mounting plate
 Ajuste vertical (Puerta móvil arriba-abajo) a través de la ranura en la placa de montaje
 Réglage vertical (porte mobile de haut en bas) via la fente sur la plaque de montage

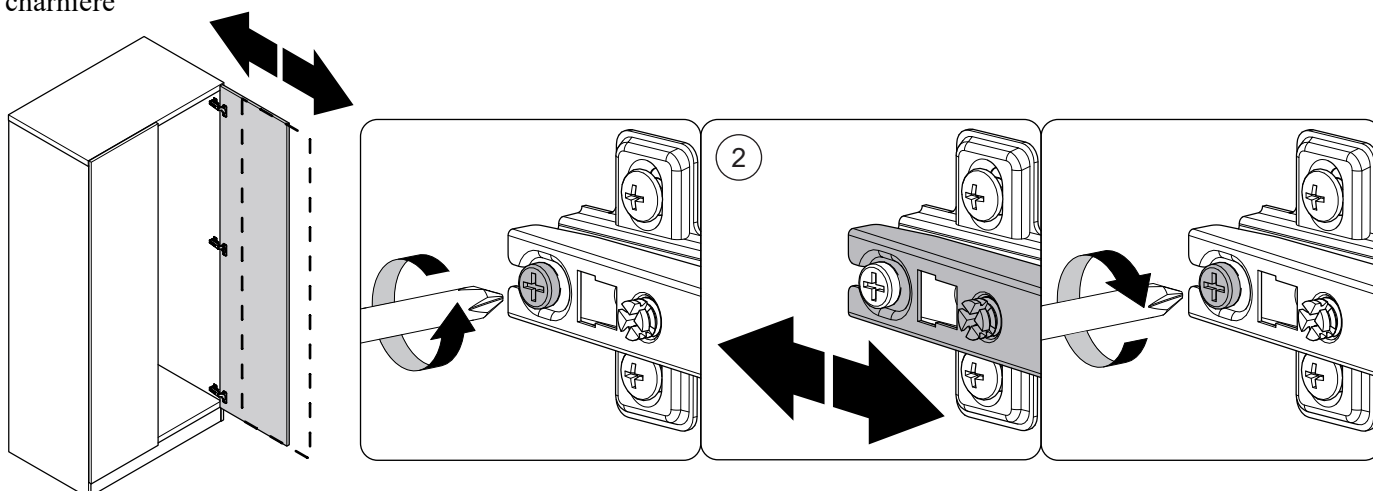

- C. Front-to-back adjustment (Spacing Door Off Cabinet) by slacking the hinge arm mounting screw
 Ajuste de adelante hacia atrás (espaciado entre la puerta y el gabinete) aflojando el tornillo de montaje del brazo de la bisagra
 Ajustement d'avant en arrière (espacement de la porte hors de l'armoire) en desserrant la vis de montage du bras de charnière



STEP 23

	
U x 2	H x 2

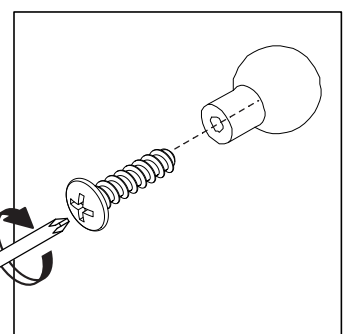
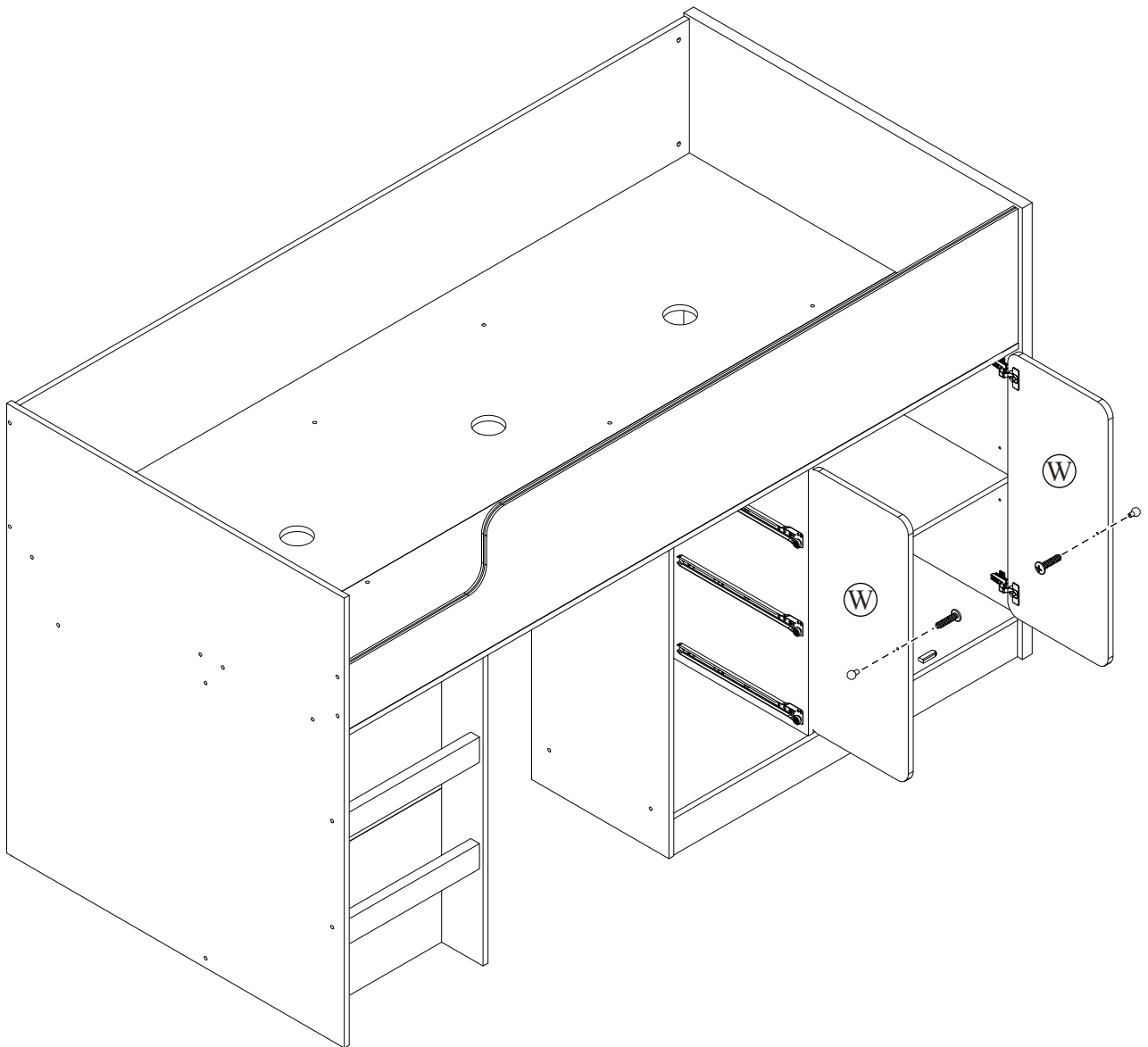

Option 1

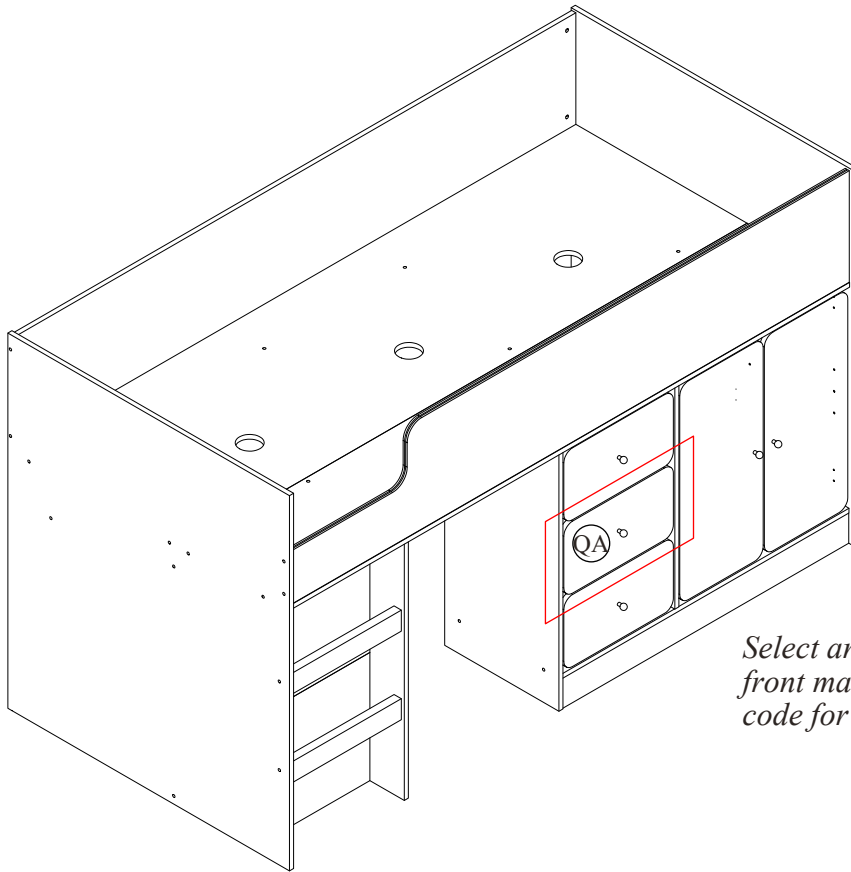

Select and install the drawer front marked with the QA code for the green colour.

or

Option 2

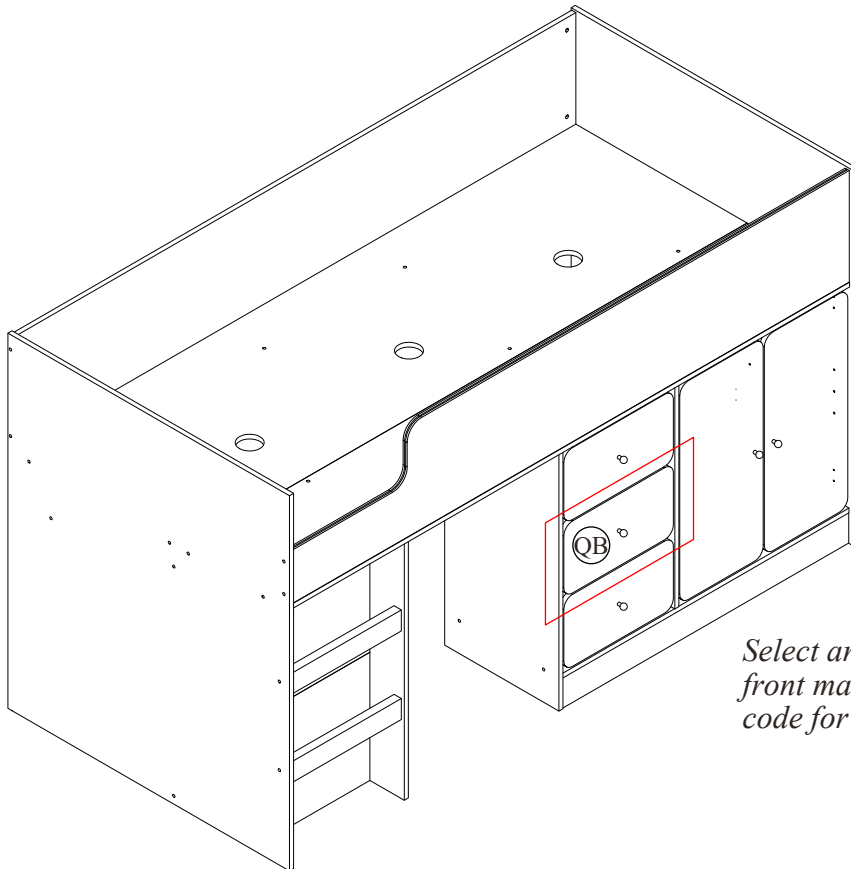

Select and install the drawer front marked with the QB code for the pink colour.

STEP 24

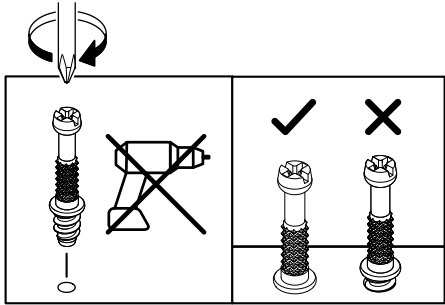
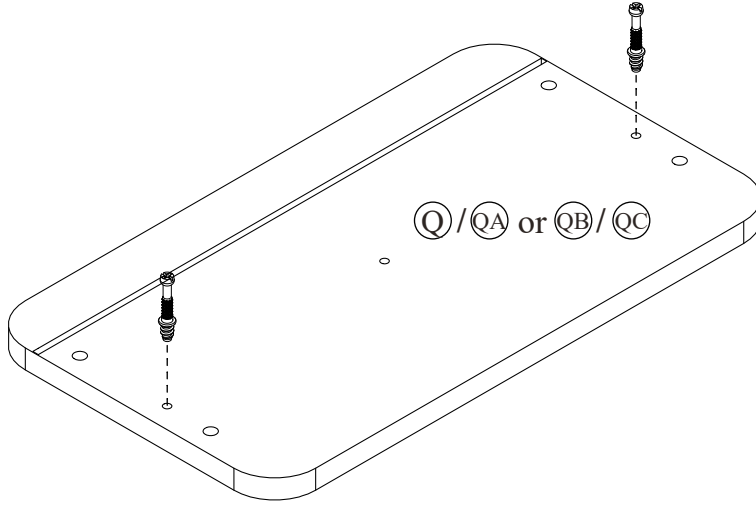
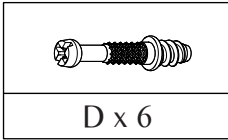

STEP 25

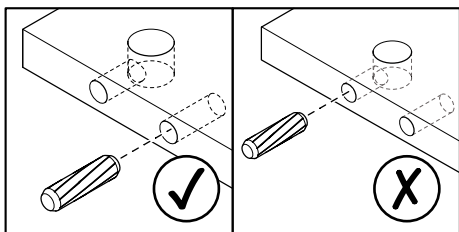
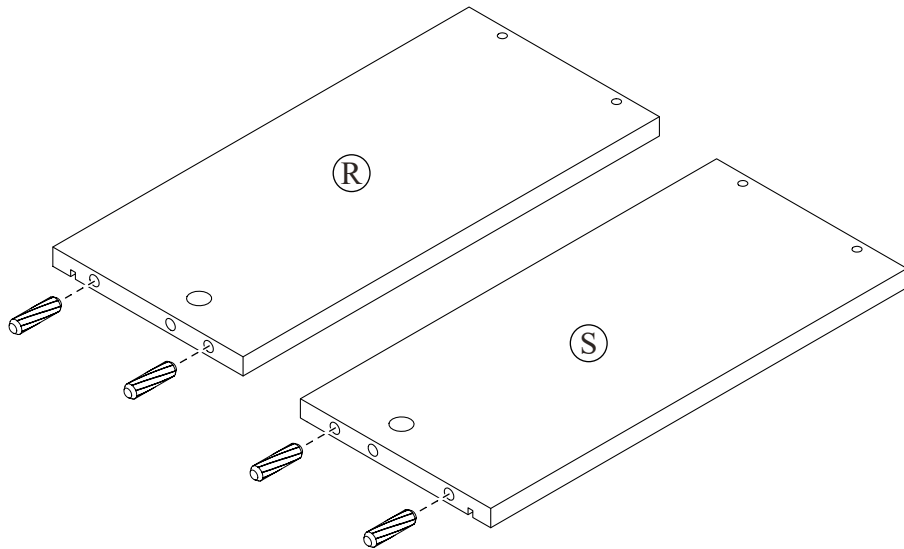
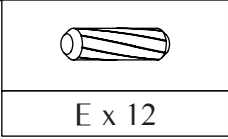

(3x)

STEP 26

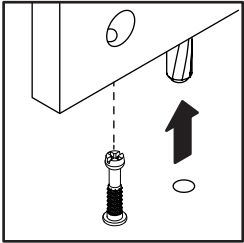
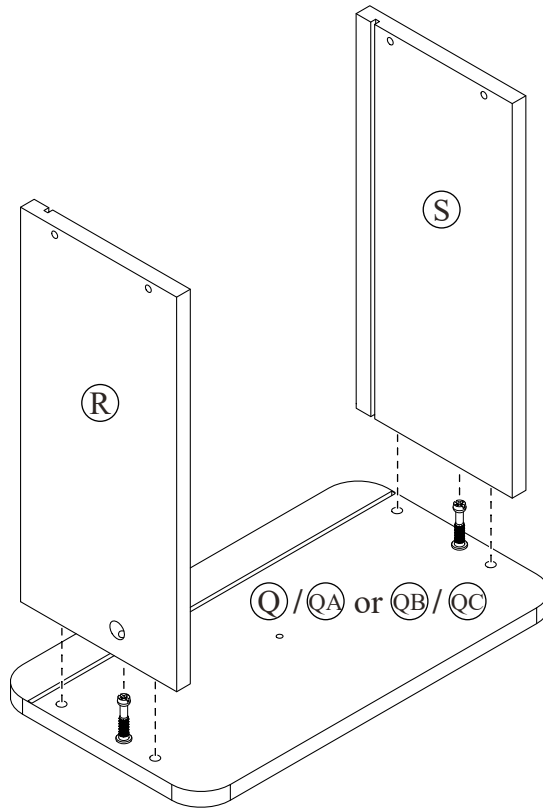

STEP 27

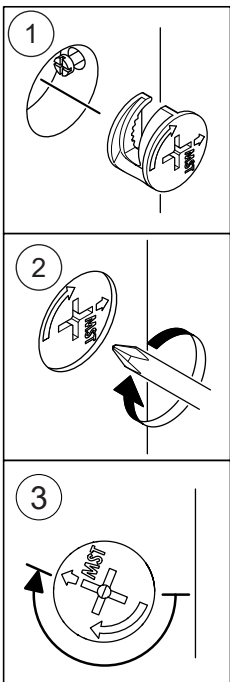
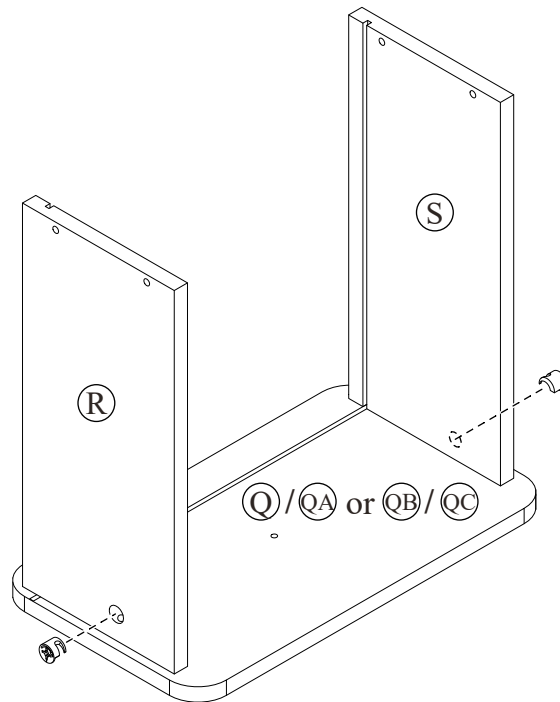
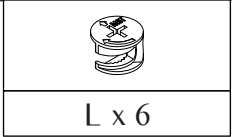

STEP 28

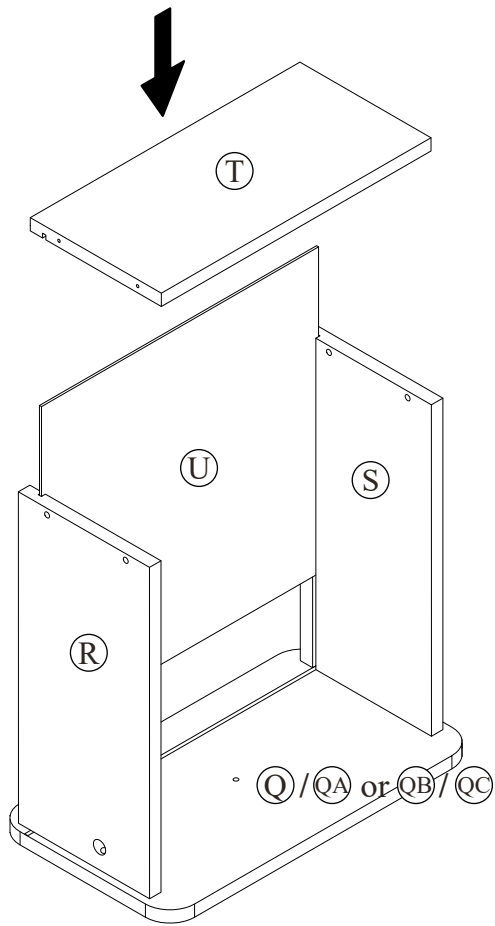

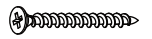

STEP 29

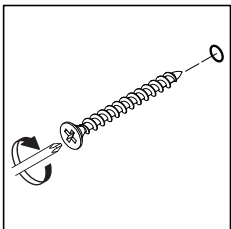
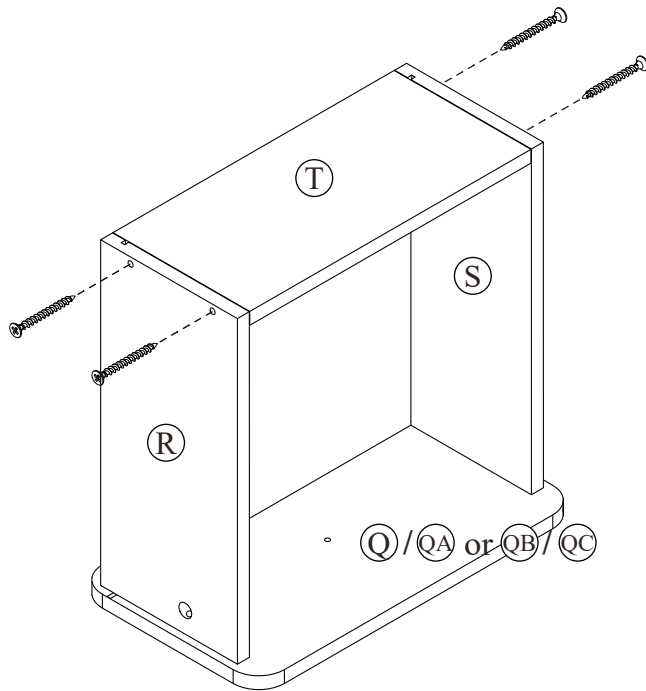

C x 12



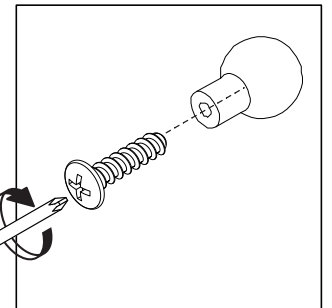
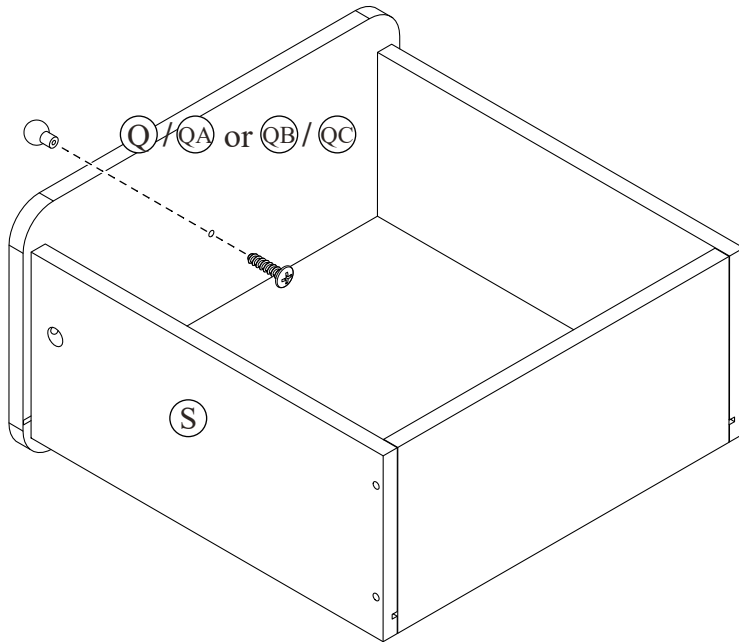

STEP 30

	
U x 3	H x 3



STEP 31



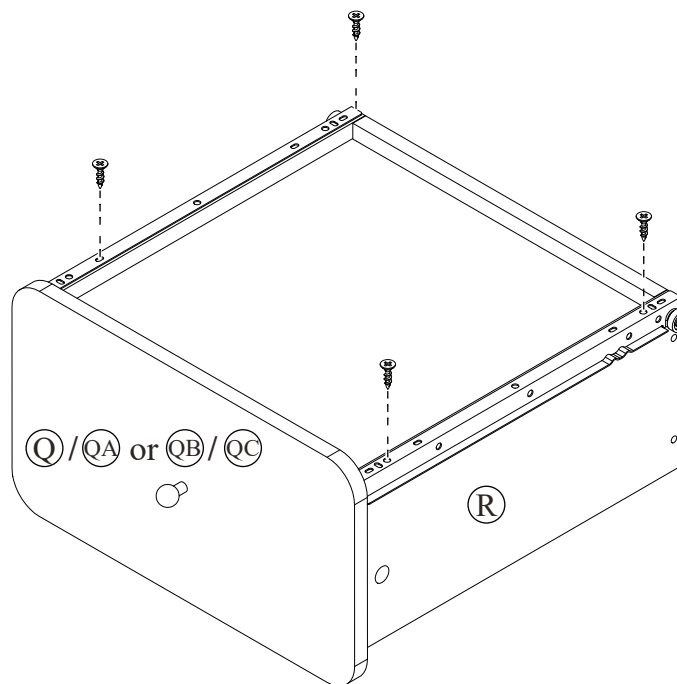
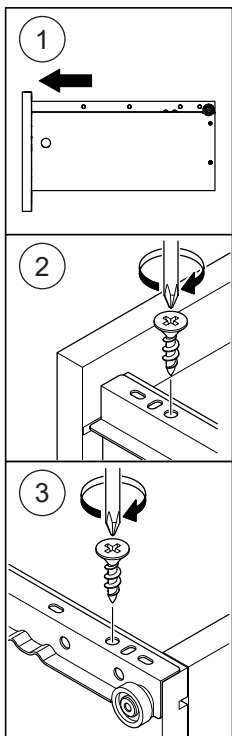

	
J x 12	S x 3 sets

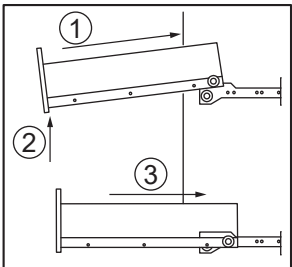
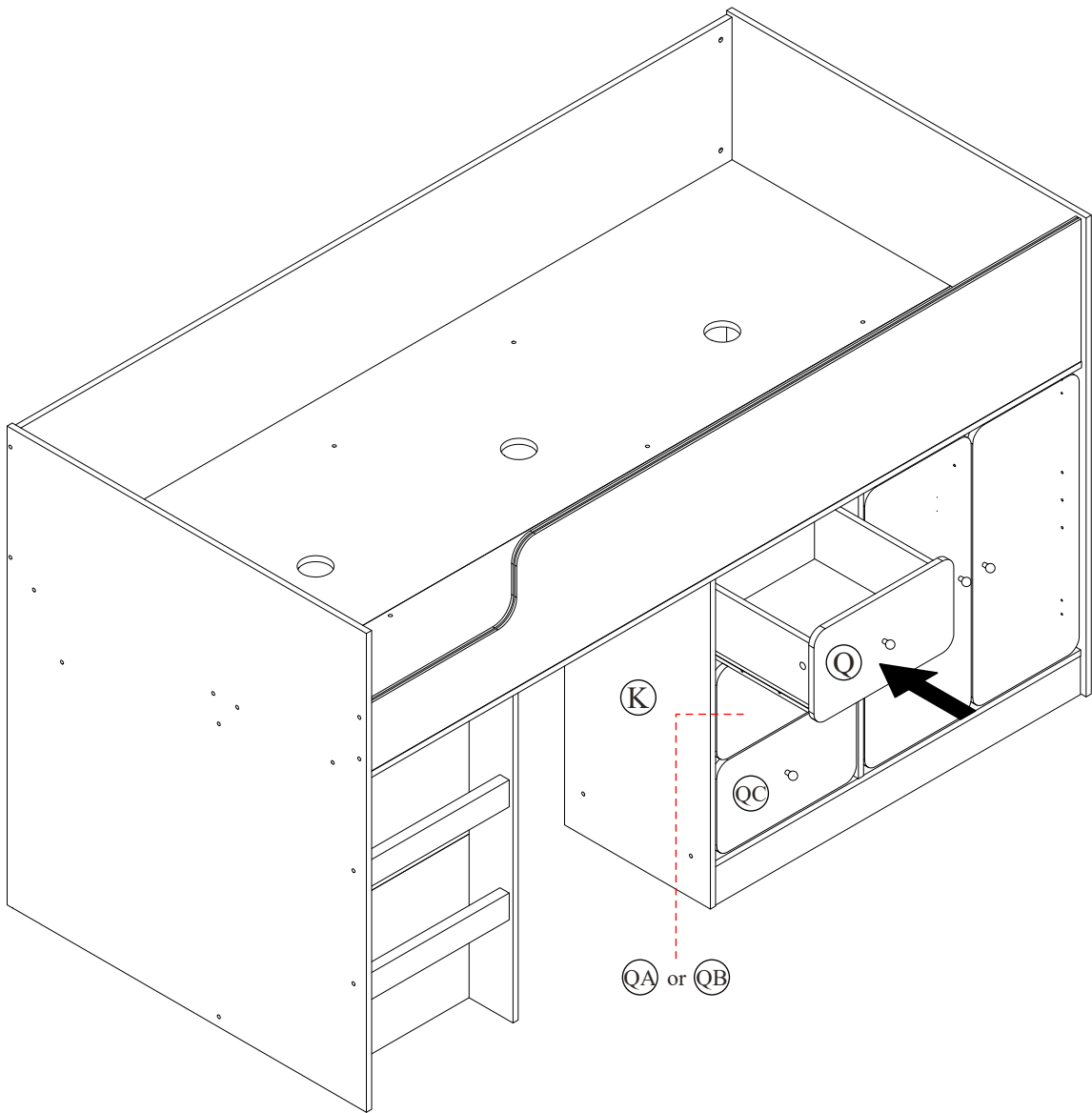

STEP 32



STEP 33

	
T x 4	F x 4
	
X x 2	Y x 2

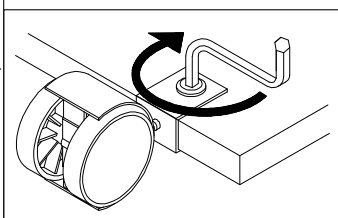
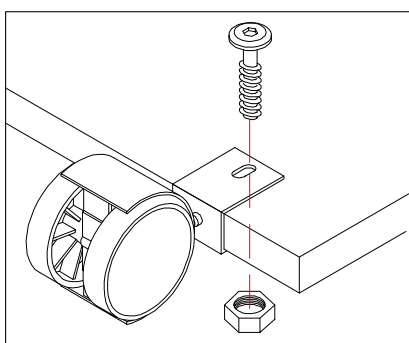
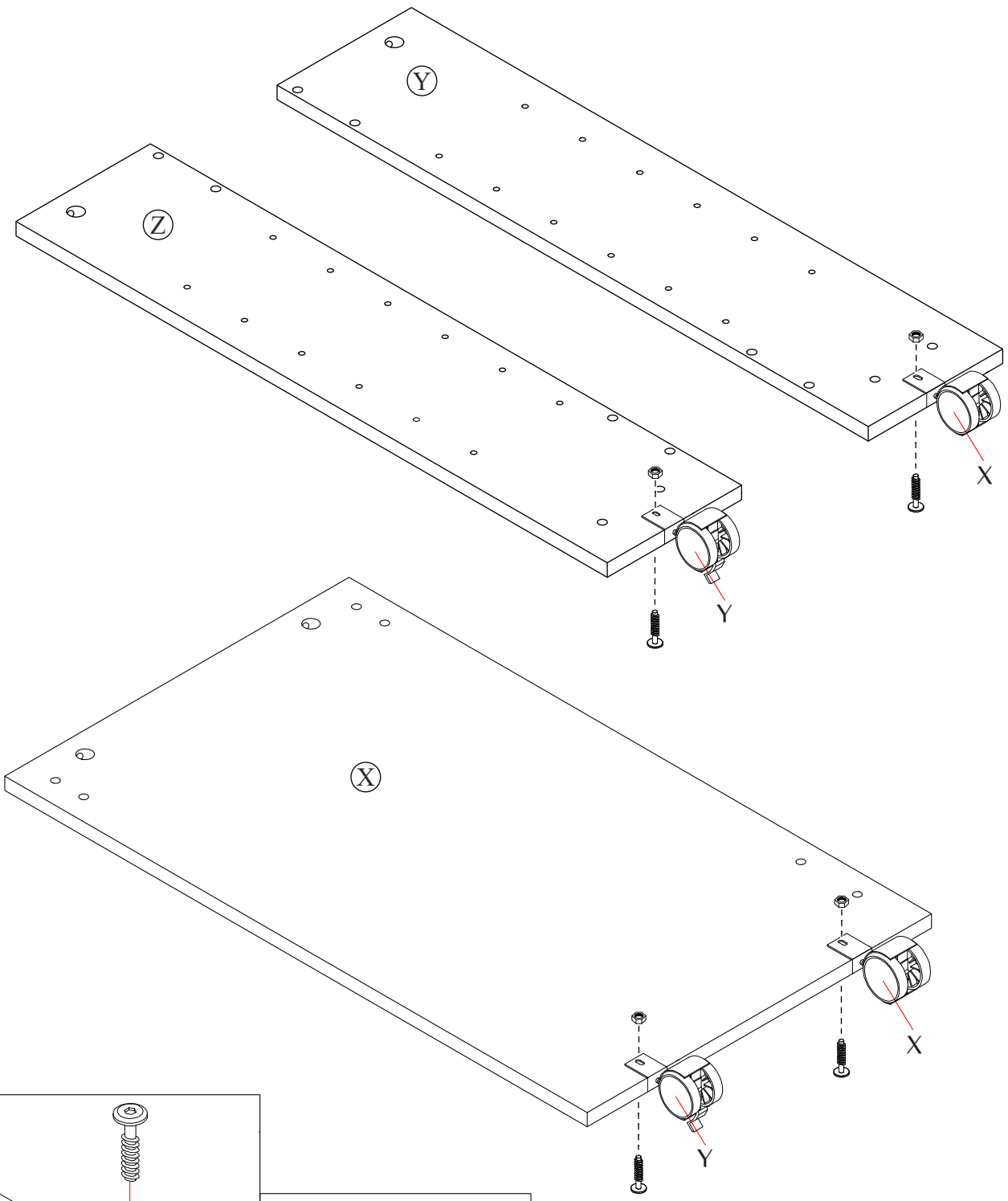

STEP 34

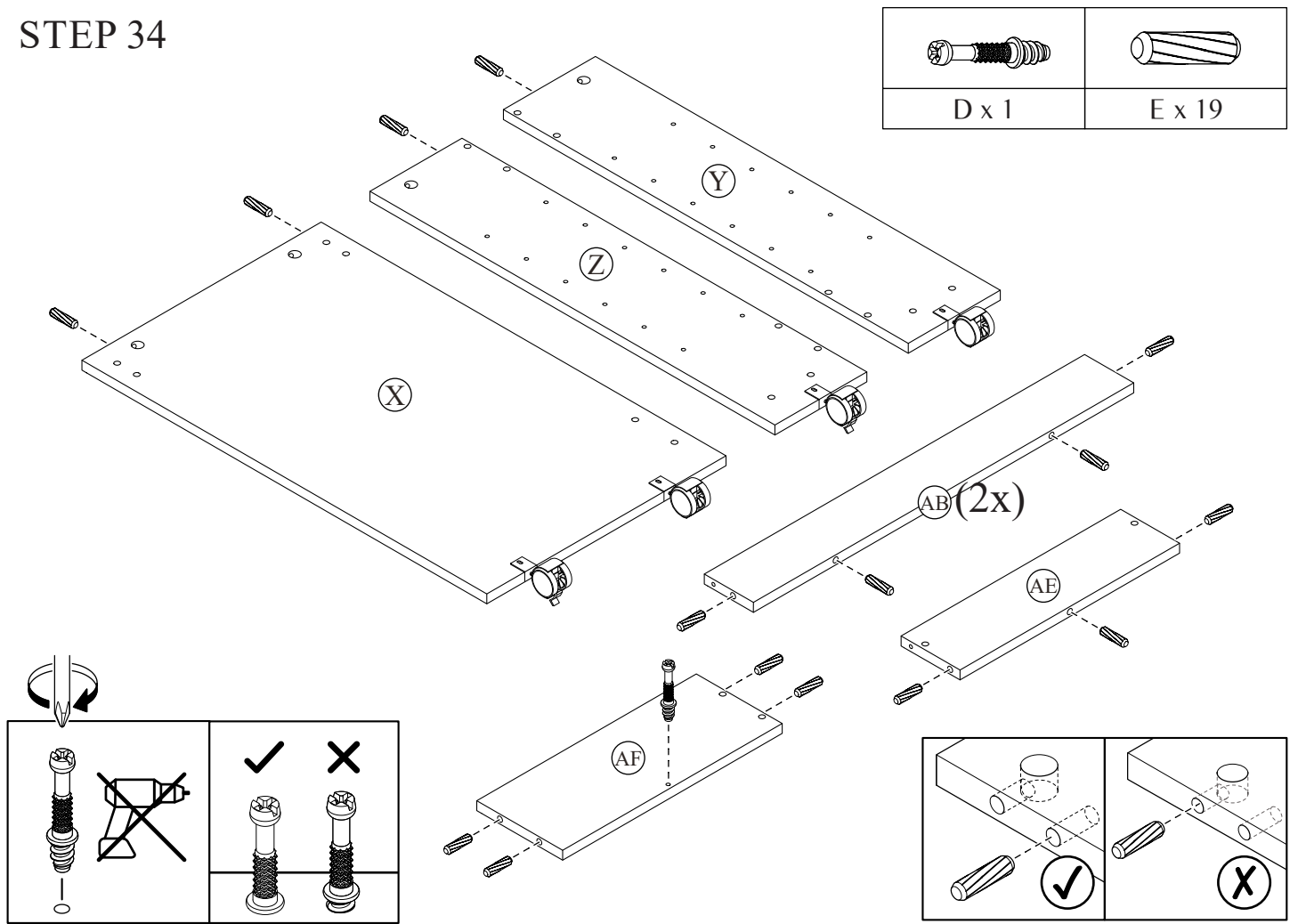

STEP 35

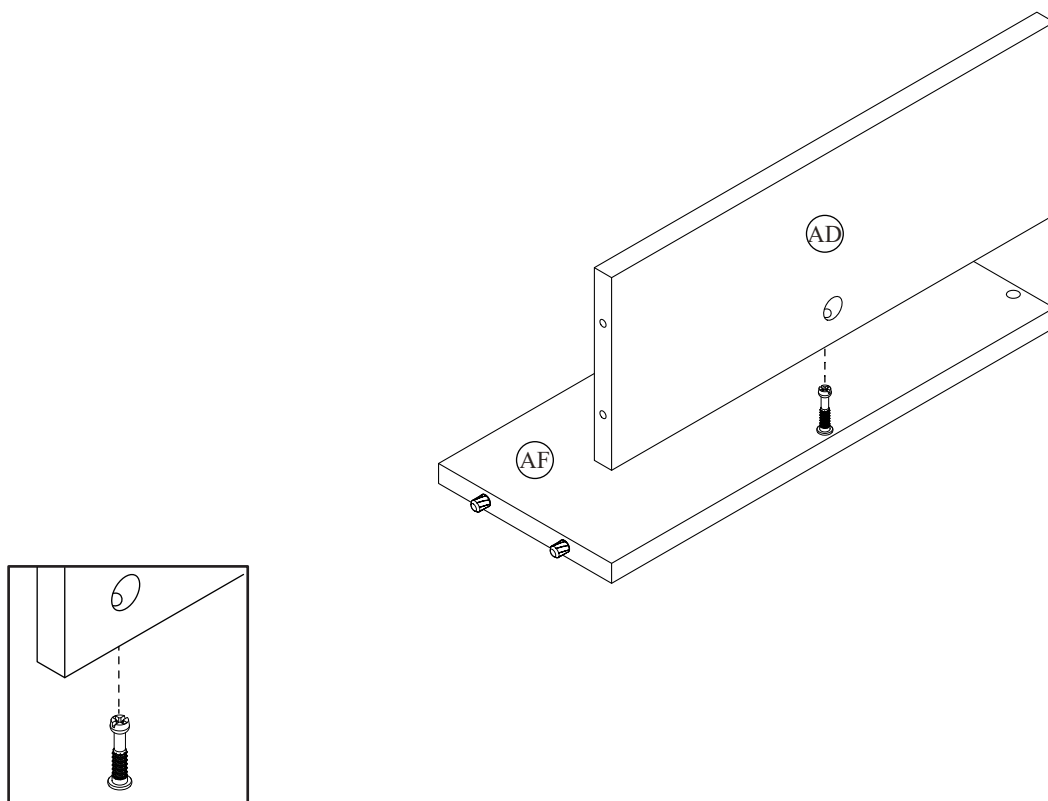

STEP 36

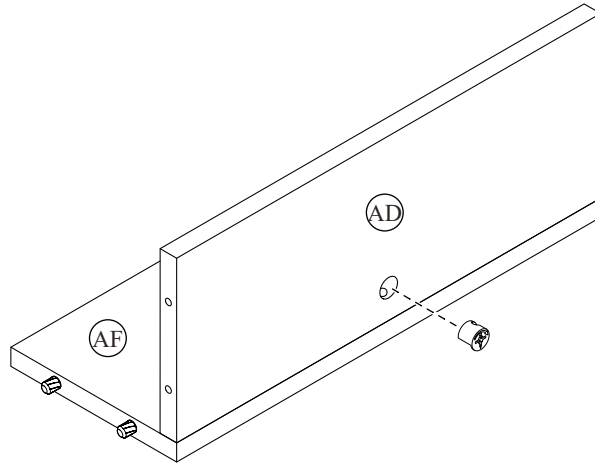
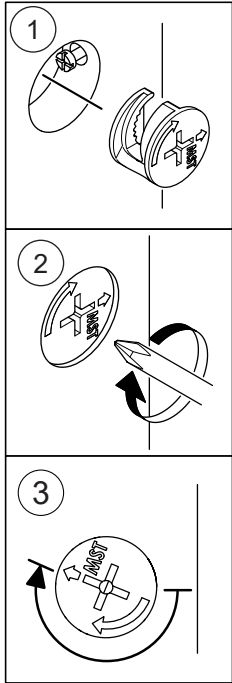
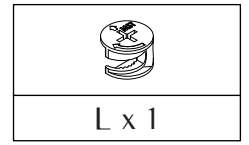

STEP 37

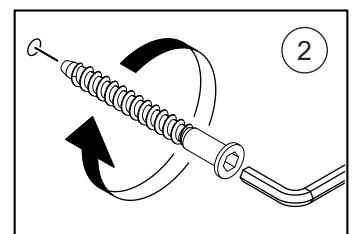
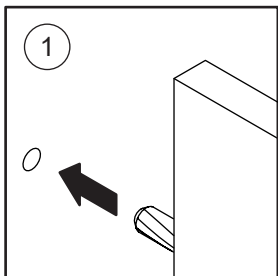
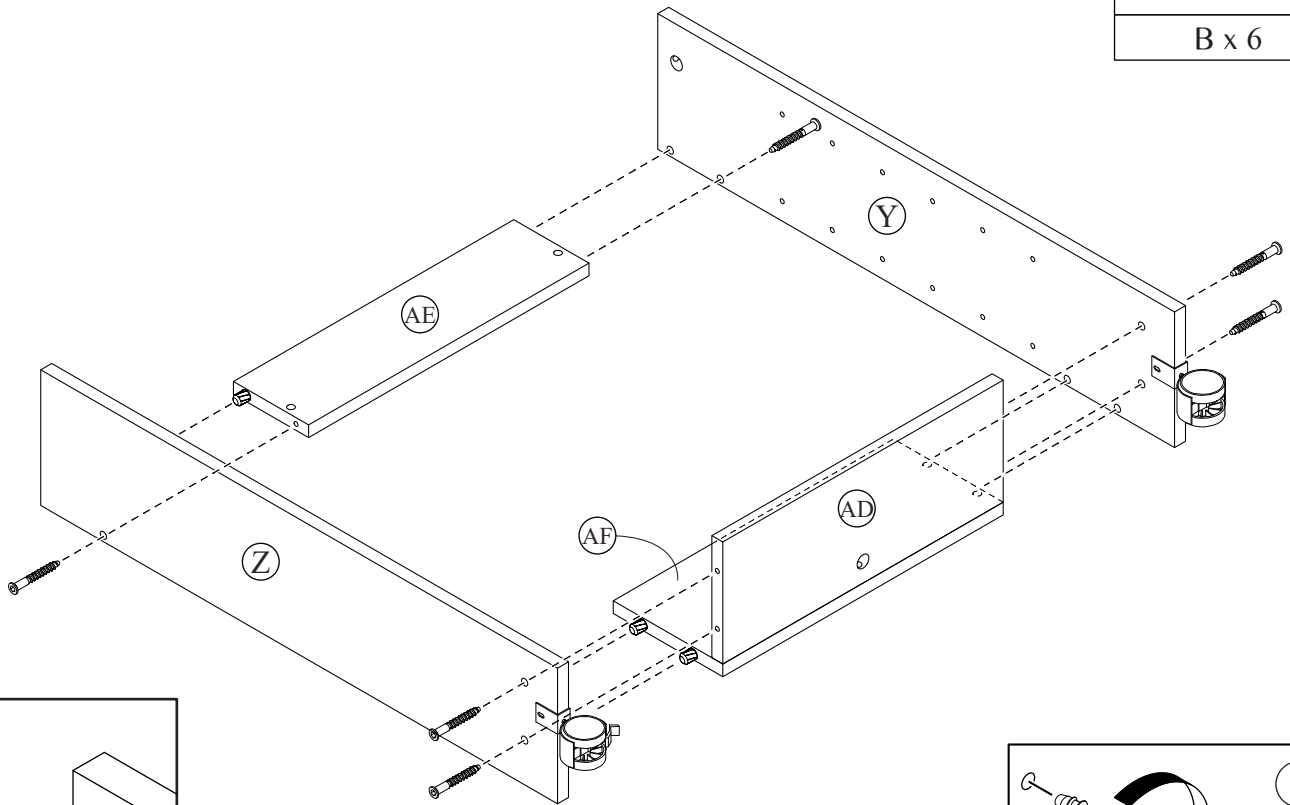
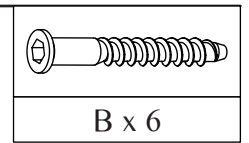

STEP 38

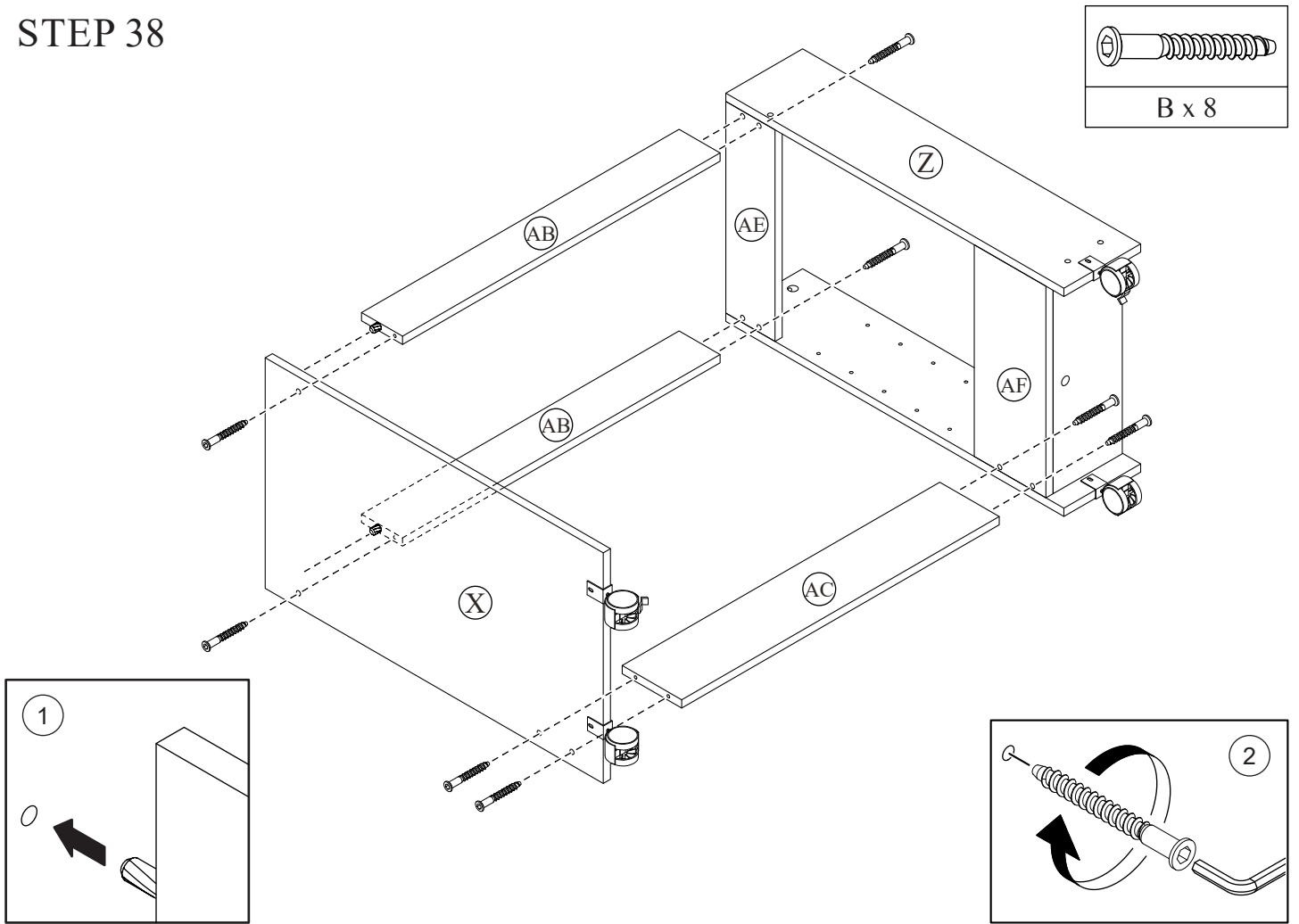

STEP 39

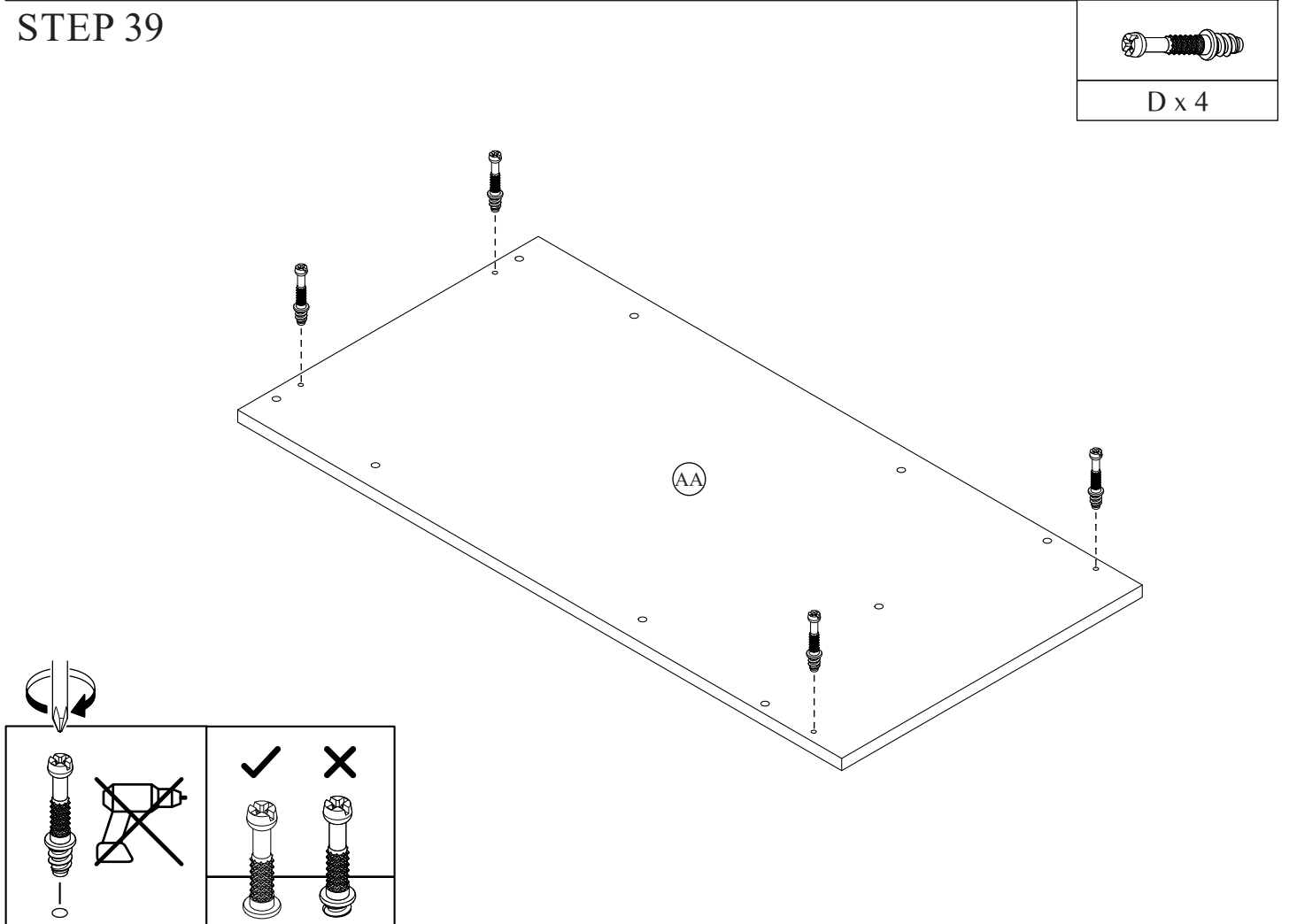

STEP 40

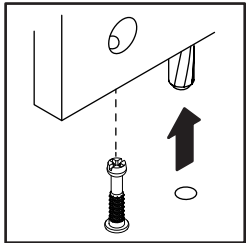
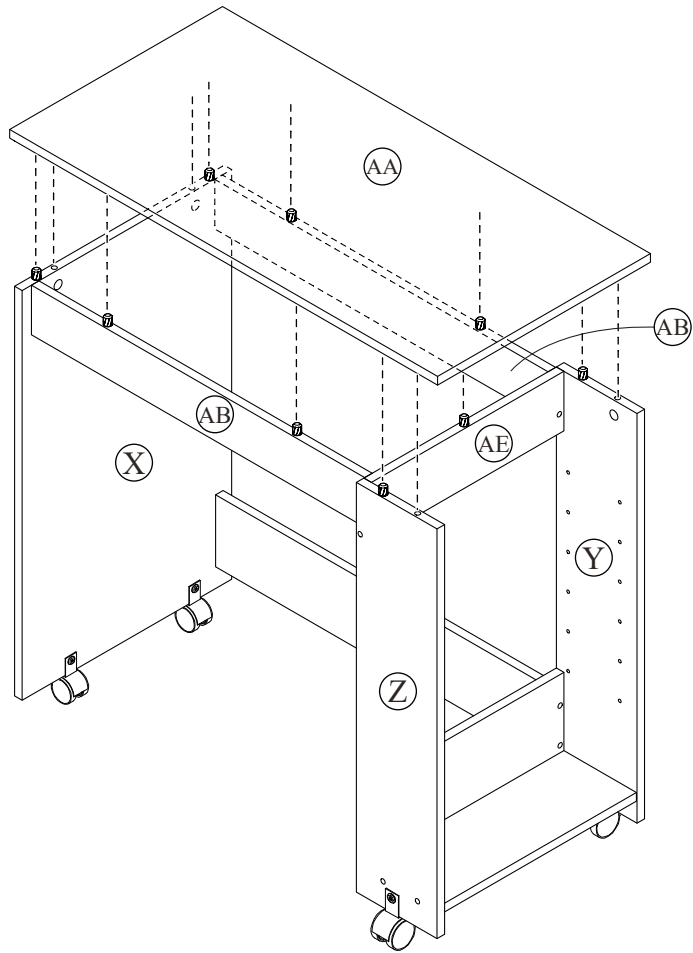



STEP 41

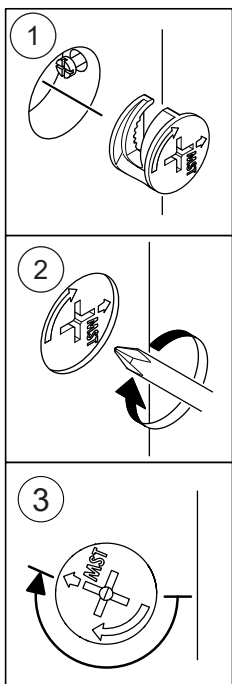
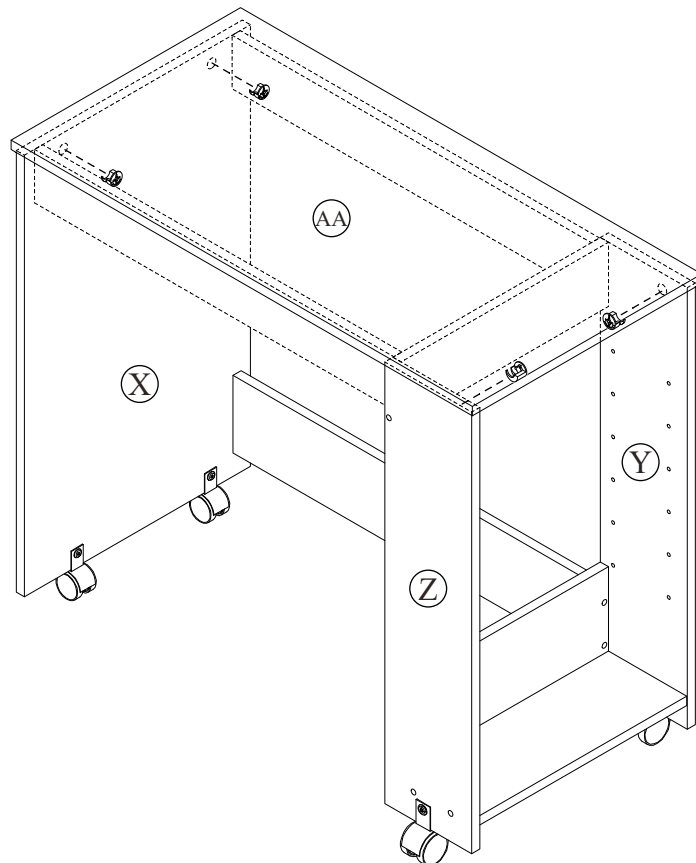

L x 4



STEP 42

	
J x 6	M x 4

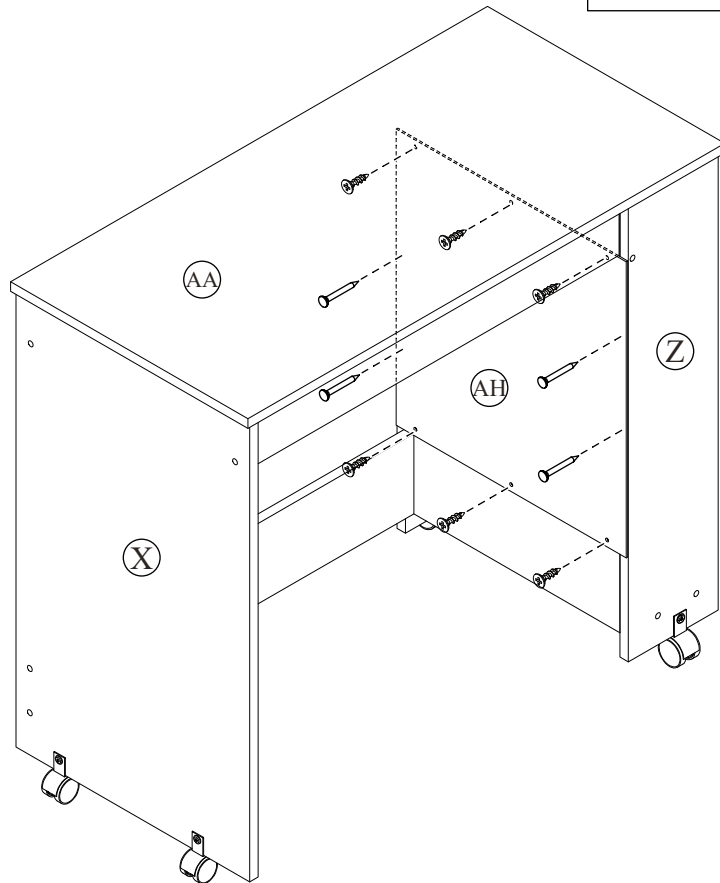
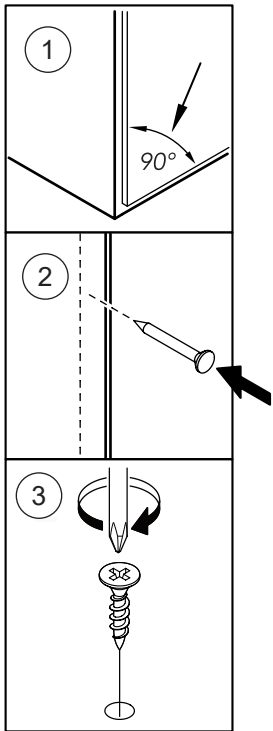

STEP 43

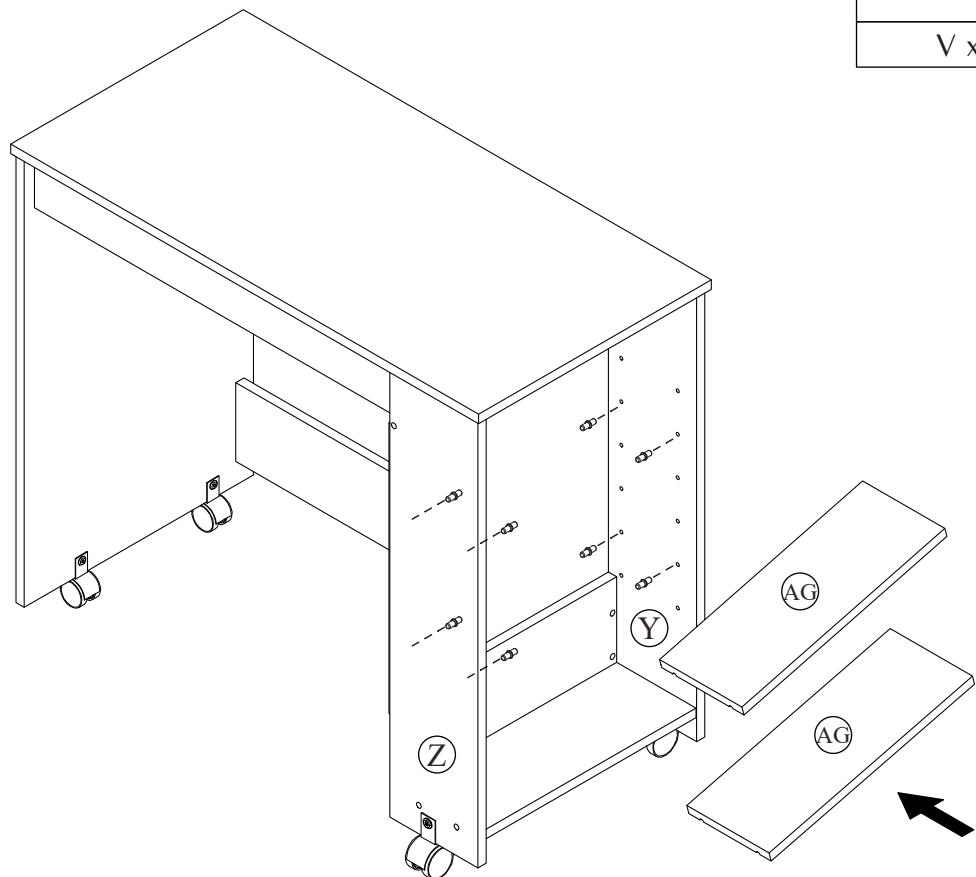
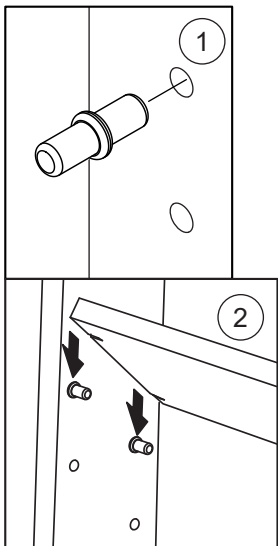

V x 8

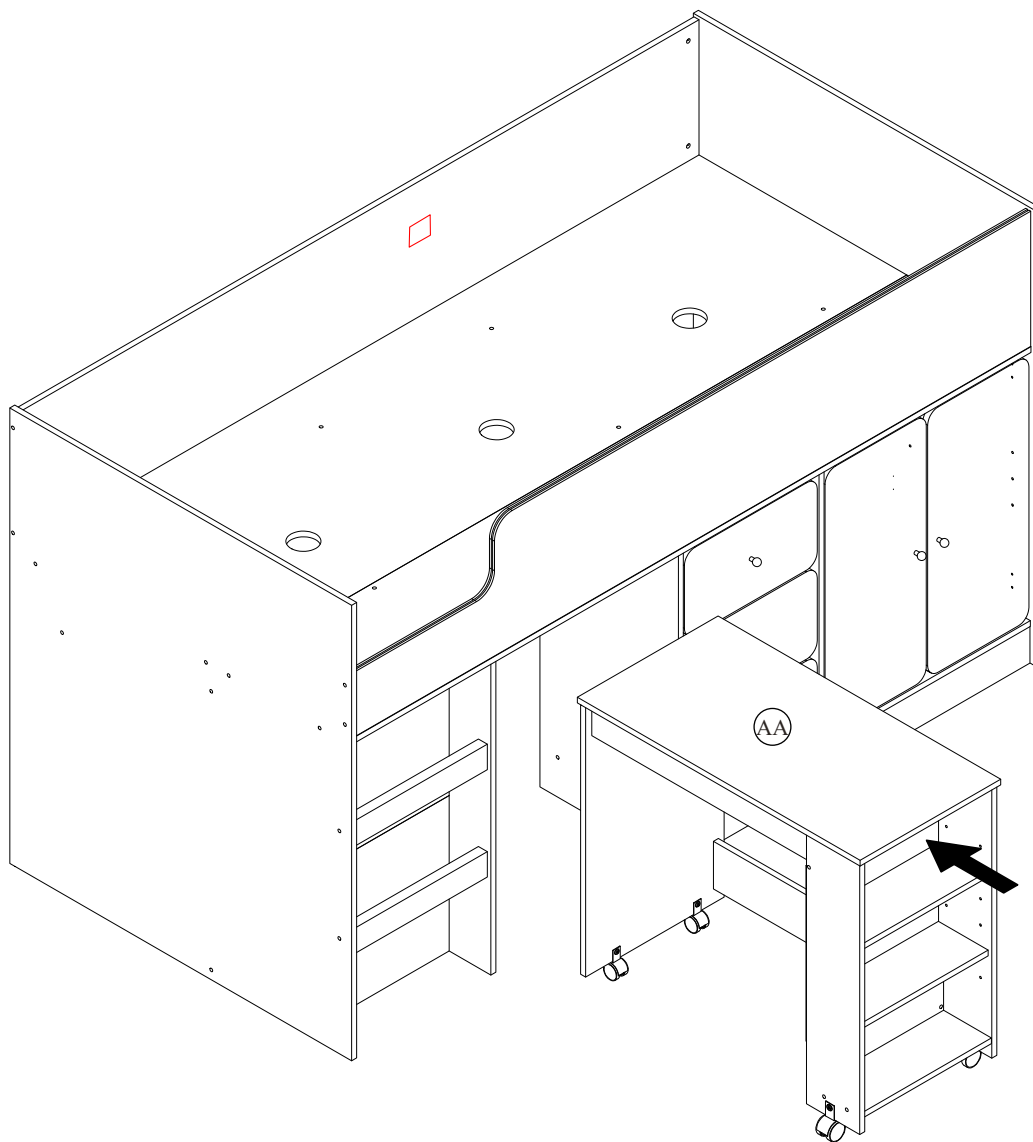

STEP 44

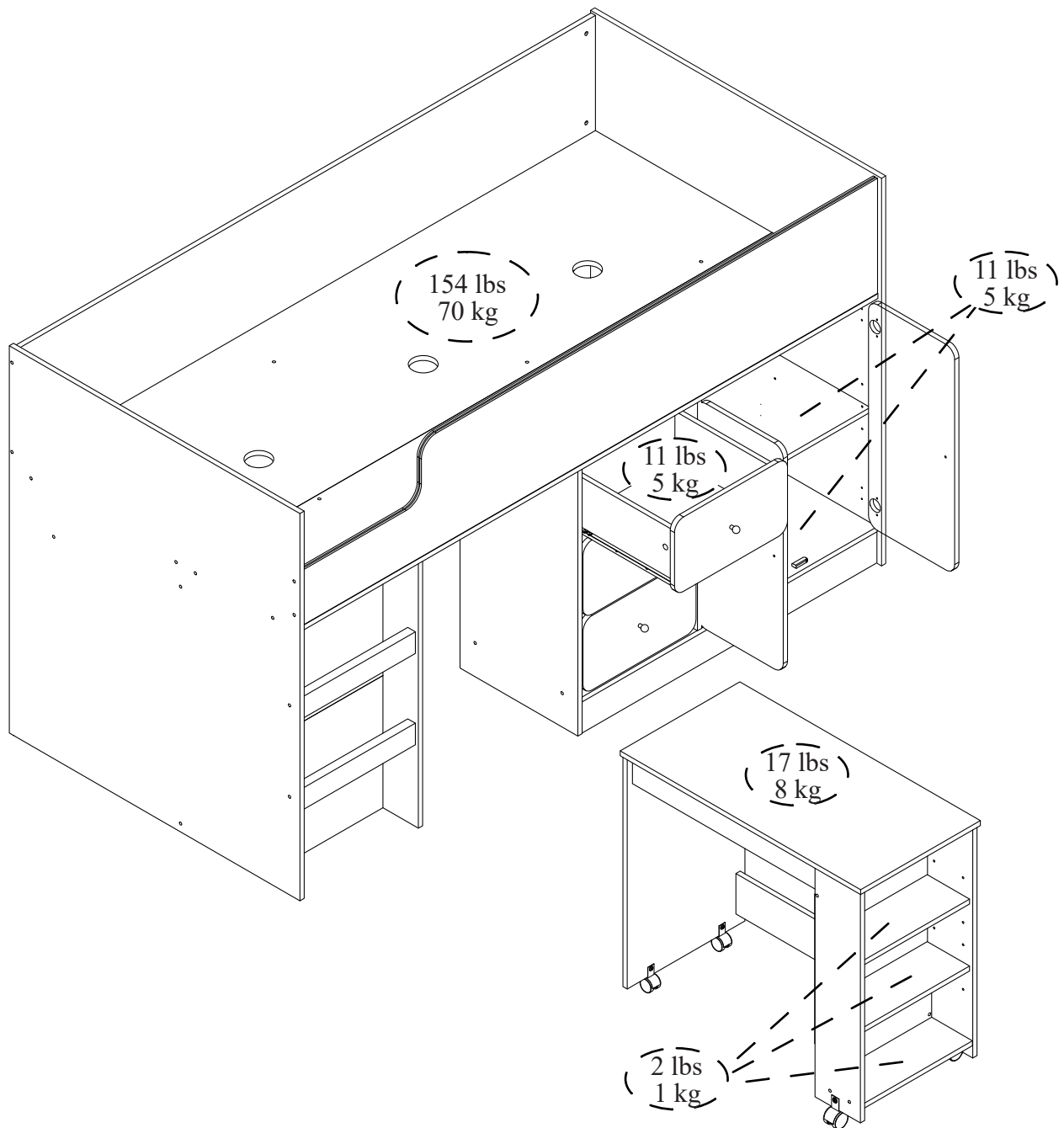

MAXIMUM LOADS CHARGES MAXIMALES / CARGA MAXIMA



This product is designed to withstand the weight noted on the plan. We are not responsible for the breakage of parts or any injury caused by failure to comply with this recommendation.

Ce produit est conçu pour supporter le poids indiqué sur le plan. Nous ne sommes pas responsables de la casse de pièces ou toute blessure causée par le non-respect de cette recommandation.

Este producto está diseñado para soportar el peso indicado en el plano. No somos responsables de la rotura de piezas o cualquier lesión causada por el incumplimiento de esta recomendación.