

# Installation Instruction

Please don't tighten the screws completely and go back later for a final tightening of all the screws after pieces are aligned with each other.

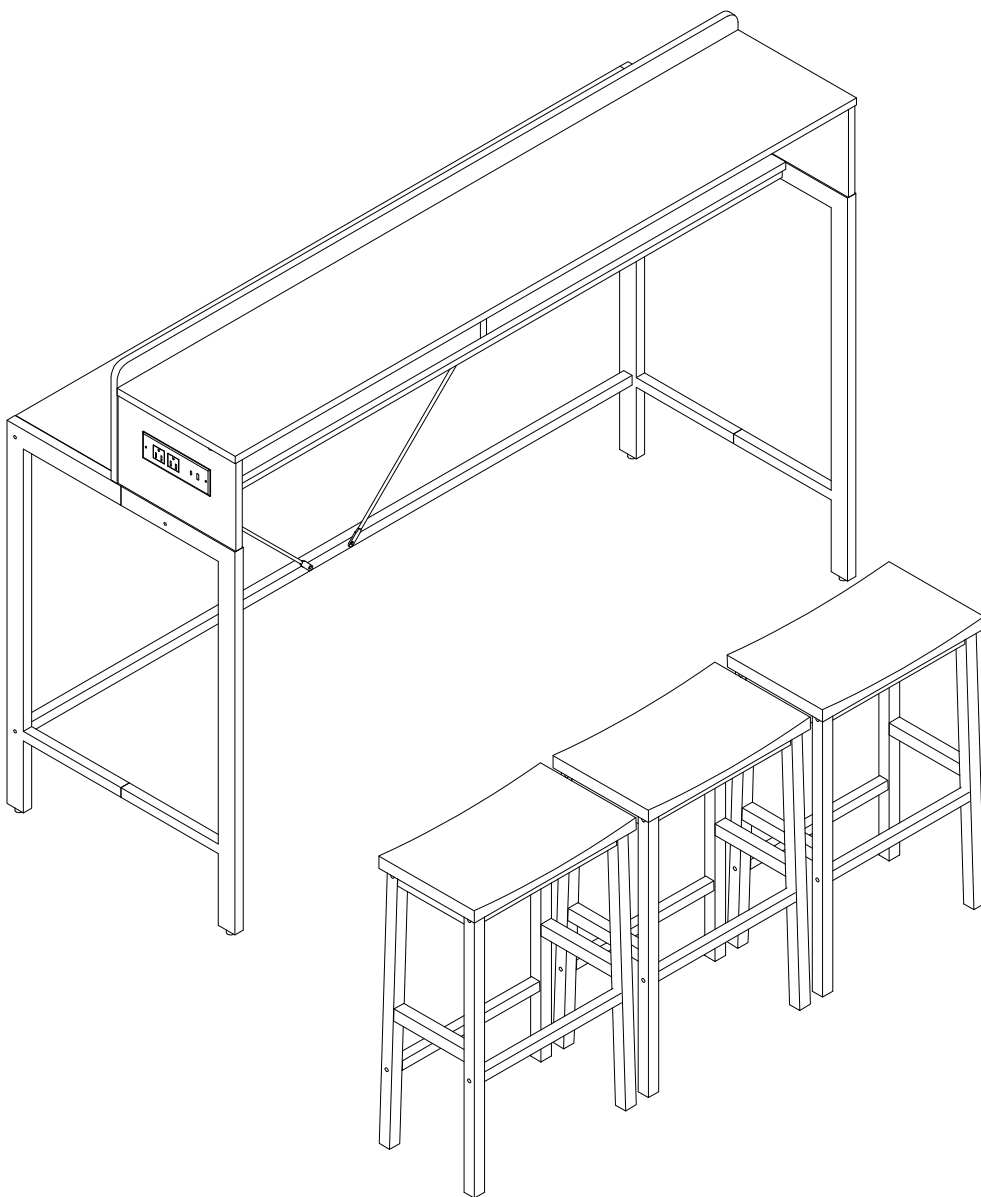

1.

## EN

Thank you for purchase on our products, please contact us if you have difficulty with assembly or need replacement parts. Our customer service is here to assist you.

Please attach your User Name or Order ID so that we can assist you better.

## WARNING

Serious or fatal injury may occur from unexpected assembly or use .

1. During the assembly process, keep all parts away from babies or children.
2. Always securely fix this product to the wall. Make sure the wall area to be drilled is free from hidden electrical wires, water and gas pipes.
3. Use of tip-over restraints may only reduce, but not eliminate the risk of tip-over.
4. Unless specially designed to accommodate, do not set heavy objects on top of this product.
5. Place the heaviest items on the lowest shelf.
6. Never allow children to climb or bang on drawers, doors or shelves.

## DE

Vielen Dank für Ihren Kauf von unseren Produkten. Bitte kontaktieren Sie uns, wenn Sie Probleme mit Montage haben oder Ersatzteile benötigen. Unser Kundenservice ist für Sie da.

Bitte geben Sie Ihren Benutzernamen oder Ihre Bestellnummer an, damit wir Sie besser unterstützen können.

## WARNUNG

Bei unerwarteter Montage oder Verwendung können schwere oder tödliche Verletzungen auftreten.

1. Legen Sie in den Montageprozess alle Teile weg von Babys oder Kindern.
2. Stellen Sie sicher, dass der gebohrte Wandbereich frei von verborgenen Stromkabeln, Wasser- und Gasleitungen ist, wenn Sie dieses Produkt an der Wand befestigen.
3. Die Verwendung von Kippsicherungen kann die Gefahr eines Kippens nur verringern, jedoch nicht beseitigen.
4. Setzen Sie bitte keine schweren Gegenstände auf dieses Produkt, es sei denn, dass das Produkt speziell für die Unterbringung konzipiert wird.
5. Legen Sie bitte die schwersten Gegenstände auf das unterste Regal.
6. Erlauben Sie nie Kindern, auf Schubladen, Türen oder Regale zu klettern oder zu knallen.

## USING CAM LOCK AND QUICKFIT

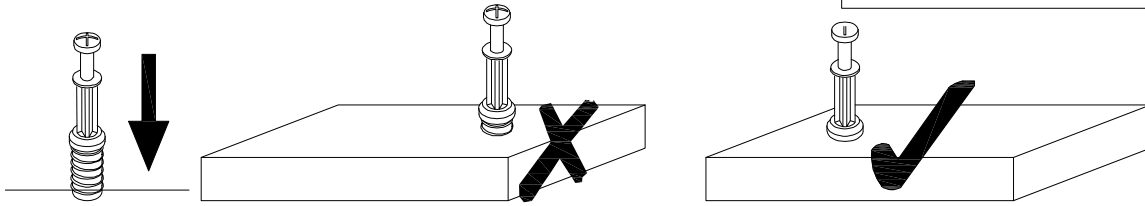

EN\_QUICKFIT: Tighten quickfit until shoulder is flush with panel. Do not overtighten or undertighten.

FR\_RACCORD RAPIDE: Faites serrer le raccord rapide jusqu'à ce que l'épaulement soit parfaitement encastré dans le panneau. Il ne faut ni trop serrer ni insuffisamment serrer.

ES\_QUICKFIT: Apriete quickfit hasta que el hombro se descargue con el panel. NO lo sobreapriete ni lo apriete poco.

DE\_QUICKFIT: Ziehen Sie den quickfit fest, bis die Schulter mit der Platte bundig ist. Bitte nicht zu fest oder zu schwach anziehen.

IT\_MONTAGGIO RAPIDO: Stringere il montaggio rapido fino a quando la spalla e a filo con il pannello, non stringere troppo o troppo poco.

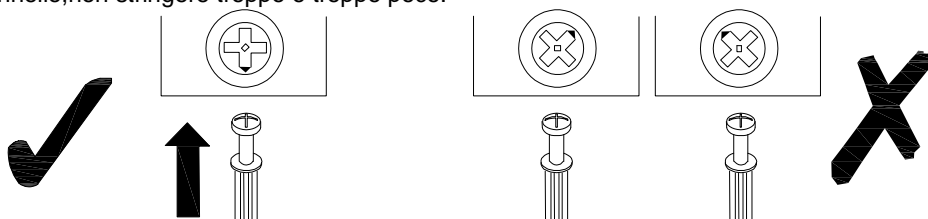

EN\_CAM LOCK: When fitting cam lock, ensure starting position is correct before you insert connecting quickfit.

FR\_SERRURE BATTEUSE: Avant d'insérer la serrure batteuse, veillez à la bonne orientation avant d'insérer le raccord rapide.

ES\_CIERRE DE LA CAMARA: Cuando instale el cierre de la camara, asegúrese de que la posición de inicio es correcta antes de que inserte el quickfit conector.

DE\_CAM-LOCK: Achten Sie bei der Montage des Cam-locks auf die richtige Ausgangsposition, bevor Sie den Quickfit einsetzen.

IT\_BLOCCAGGIO A CAMMA: Quando si monta il bloccaggio a camma, assicurarsi che la posizione iniziale sia corretta prima di inserire il montaggio rapido di collegamento.

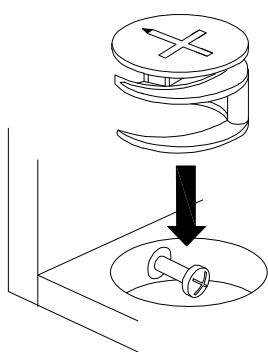

EN\_Quickfit head should be in the centre of the cam lock when the two panels are joined.

Cam lock should be inserted before quickfit.

FR\_Lorsque les deux panneaux sont assemblés, la tête du raccord rapide doit reposer au centre de la serrure batteuse.

Il faut insérer la serrure batteuse avant le raccord rapide.

ES\_EL cabezal del quickfit debe estar en el centro del cierre de la camara cuando se unan los dos paneles.

Se debe insertar el cierre de la camara antes que el quickfit.

DE\_Der Quickfit-Kopf sollte sich in der Mitte des Cam-locks befinden, wenn die beiden Platten zusammengefügt sind.

Der Cam-lock sollte vor dem Quickfit eingesetzt werden.

IT\_La testa del montaggio rapido deve trovarsi al centro del bloccaggio a camma quando i due pannelli sono uniti.

Il Bloccaggio a Camma deve essere inserito prima del montaggio rapido.

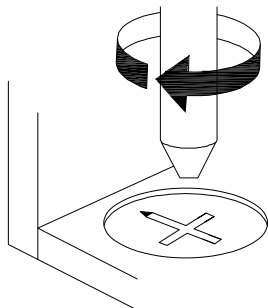

EN\_Turn cam lock clockwise to tighten.

FR\_Faites tourner la serrure batteuse dans le sens des aiguilles d'une montre pour la resserrer.

ES\_Gire el cierre de la camara en sentido horario para apretarlo.

DE\_Drehen Sie den Cam-Lock im Uhrzeigersinn, um ihn festzuziehen.

IT\_Ruotare il bloccaggio a camma in senso orario per stringere.

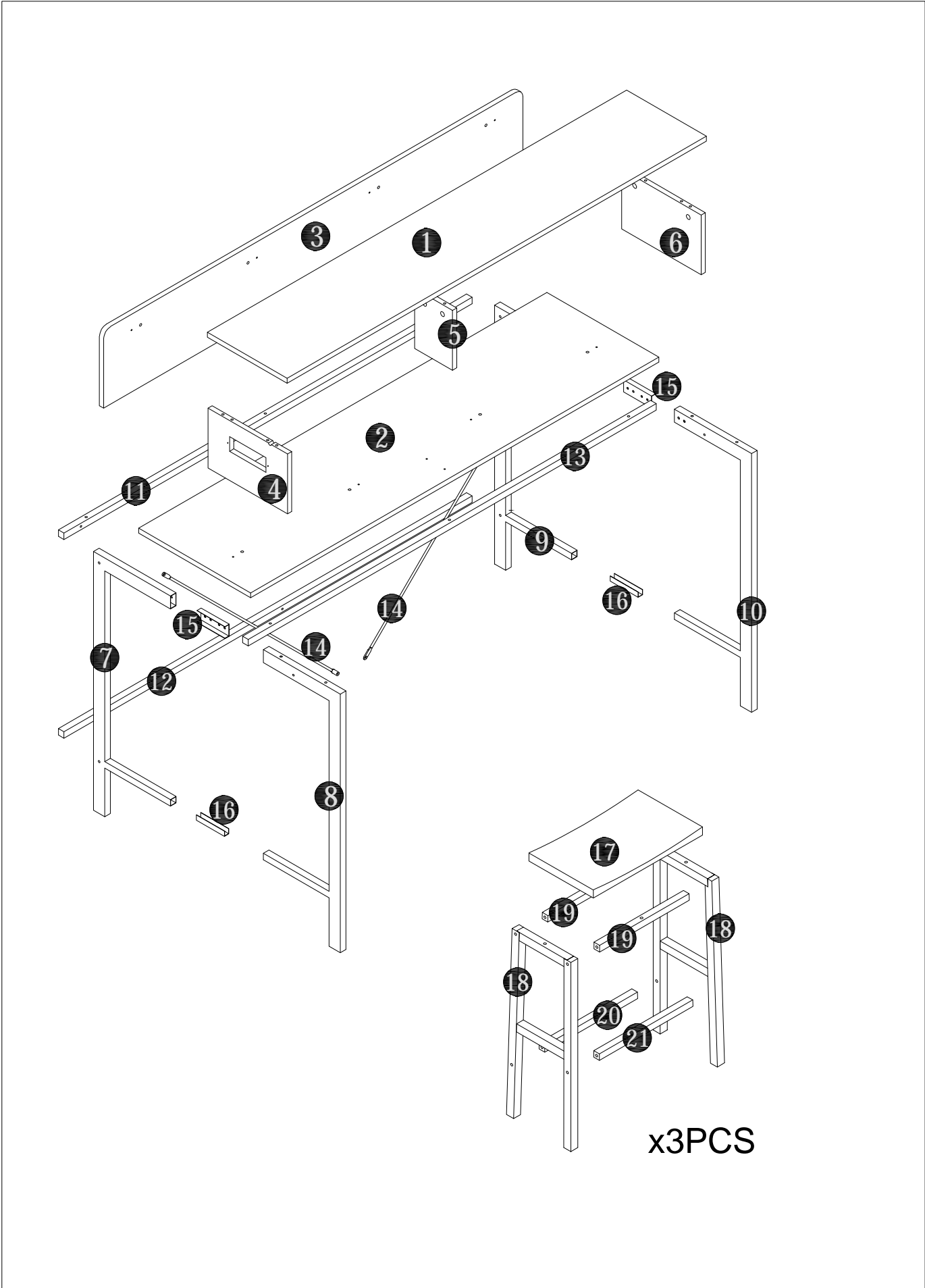

# PARTS LIST

1 x1PC

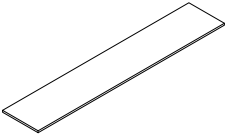

2 x1PC

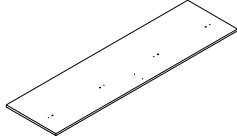

3 x1PC

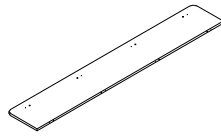

4 x1PC

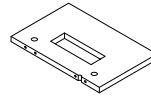

5 x1PC

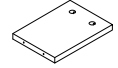

6 x1PC

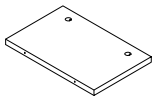

7 x1PC

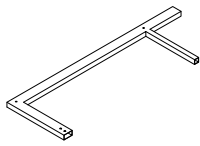

8 x1PC

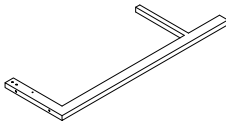

9 x1PC

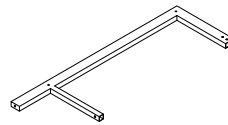

10 x1PC

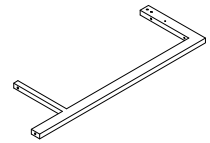

11 x1PC

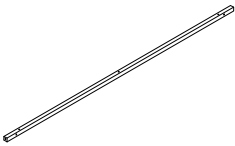

12 x1PC

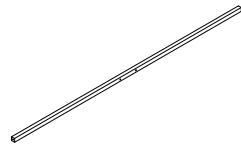

13 x1PC

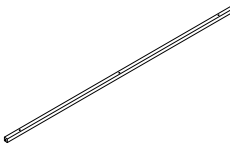

14 x2PCS

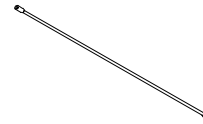

15 x2PCS



16 x2PCS



17 x3PCS

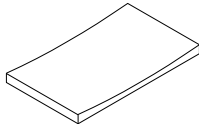

18 x6PCS

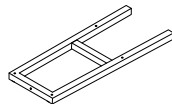

19 x6PCS

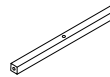



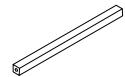



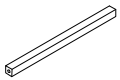



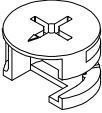

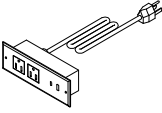
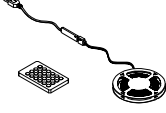
20 x3PCS

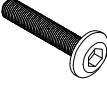

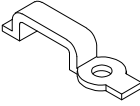
21 x3PCS

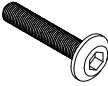

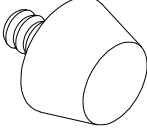

# HARDWARE LIST

<p><b>A</b></p>  <p>10+1PCS</p>	<p><b>B</b></p>  <p>10+1PCS</p>	<p><b>C</b></p>  <p>12+1PCS</p>	<p><b>D</b></p>  <p>1PC</p>	<p><b>E</b></p>  <p>1PC</p>
<p><b>F</b></p>  <p>M6*30 12+1PCS</p>	<p><b>G</b></p>  <p>M6*50 34+1PCS</p>	<p><b>H</b></p>  <p>M6*12 16+1PCS</p>	<p><b>I</b></p>  <p>4+1PCS</p>	<p><b>J</b></p>  <p>M3.5*12 6+1PCS</p>
<p><b>K</b></p>  <p>M6*35 6+1PCS</p>	<p><b>L</b></p>  <p>56x21xM4mm 1PC</p>	<p><b>M</b></p>  <p>Ø7x5x40mm 6PCS</p>	<p><b>N</b></p>  <p>56x21xM3mm 1PCS</p>	<p><b>O</b></p>  <p>Ø17*M6*10 4PCS</p>

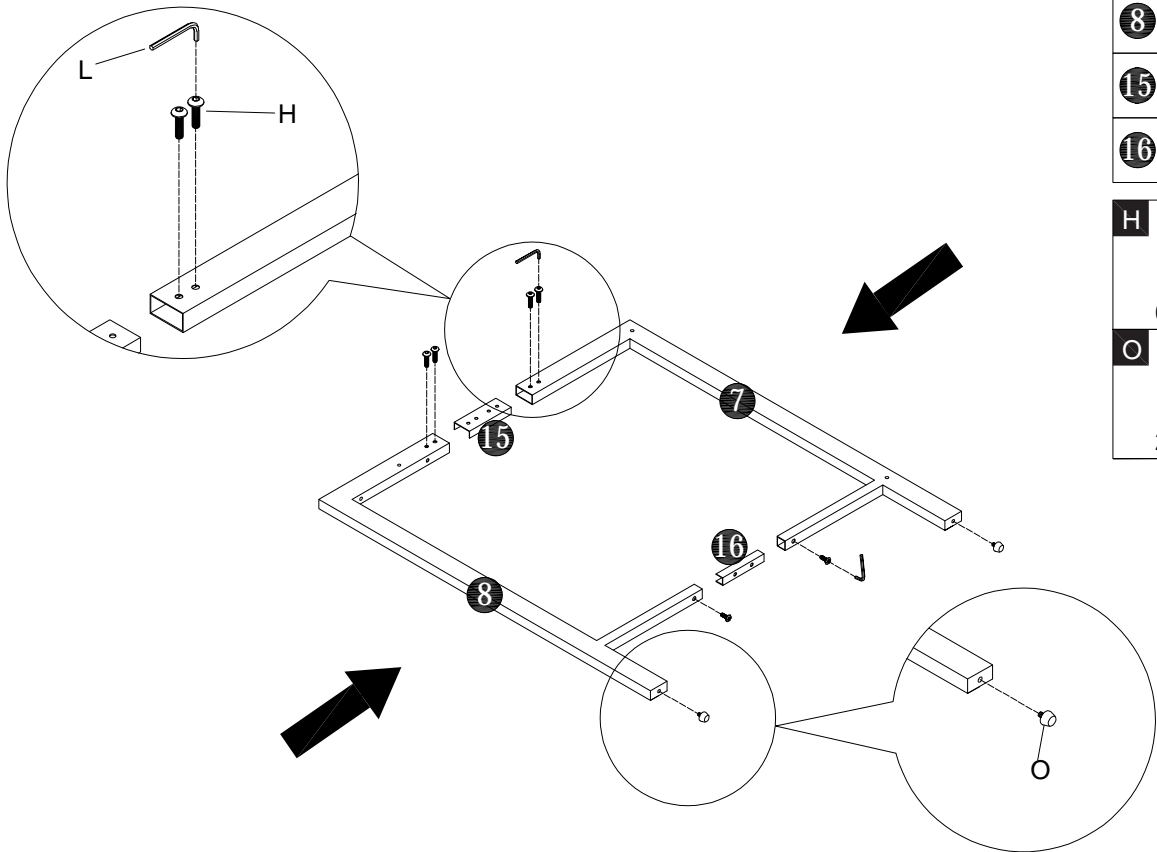
1





- 7** x1PC
- 8** x1PC
- 15** x1PC
- 16** x1PC

- H**  
  
 6PCS
- O**  
  
 2PCS

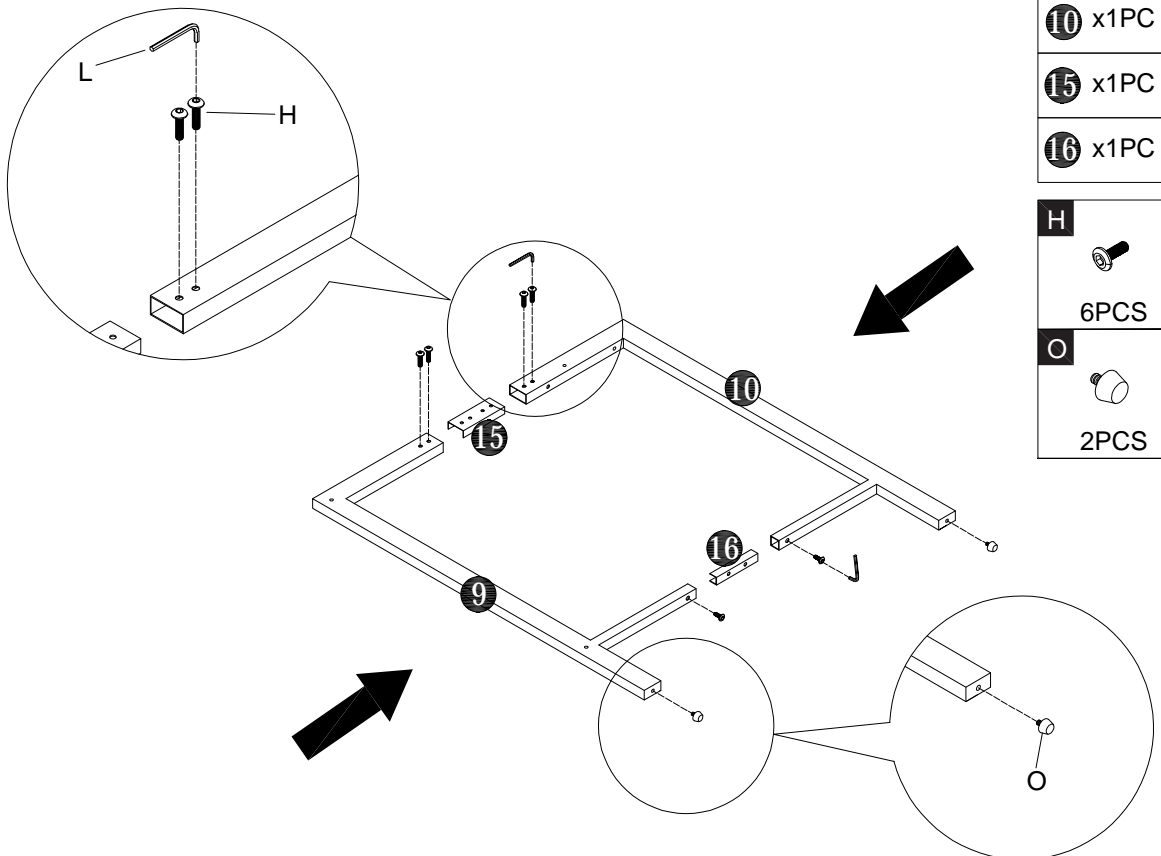
2



- 9** x1PC
- 10** x1PC
- 15** x1PC
- 16** x1PC

- H**  
  
 6PCS
- O**  
  
 2PCS

3

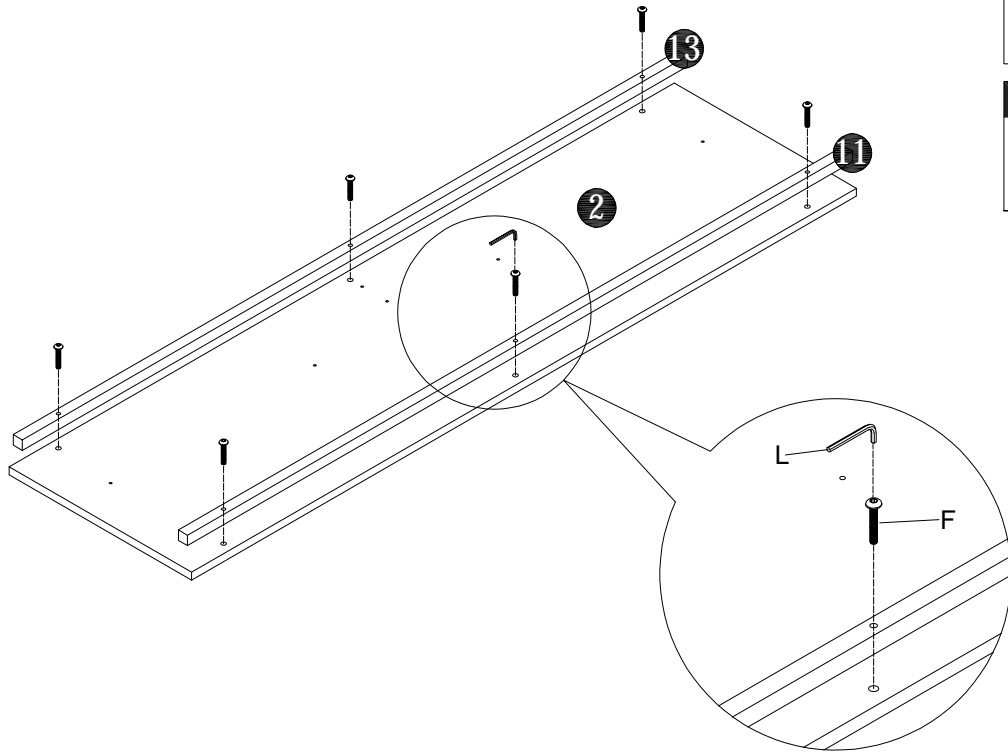

- 2 x1PC
- 11 x1PC
- 13 x1PC
- F 6PCS

4

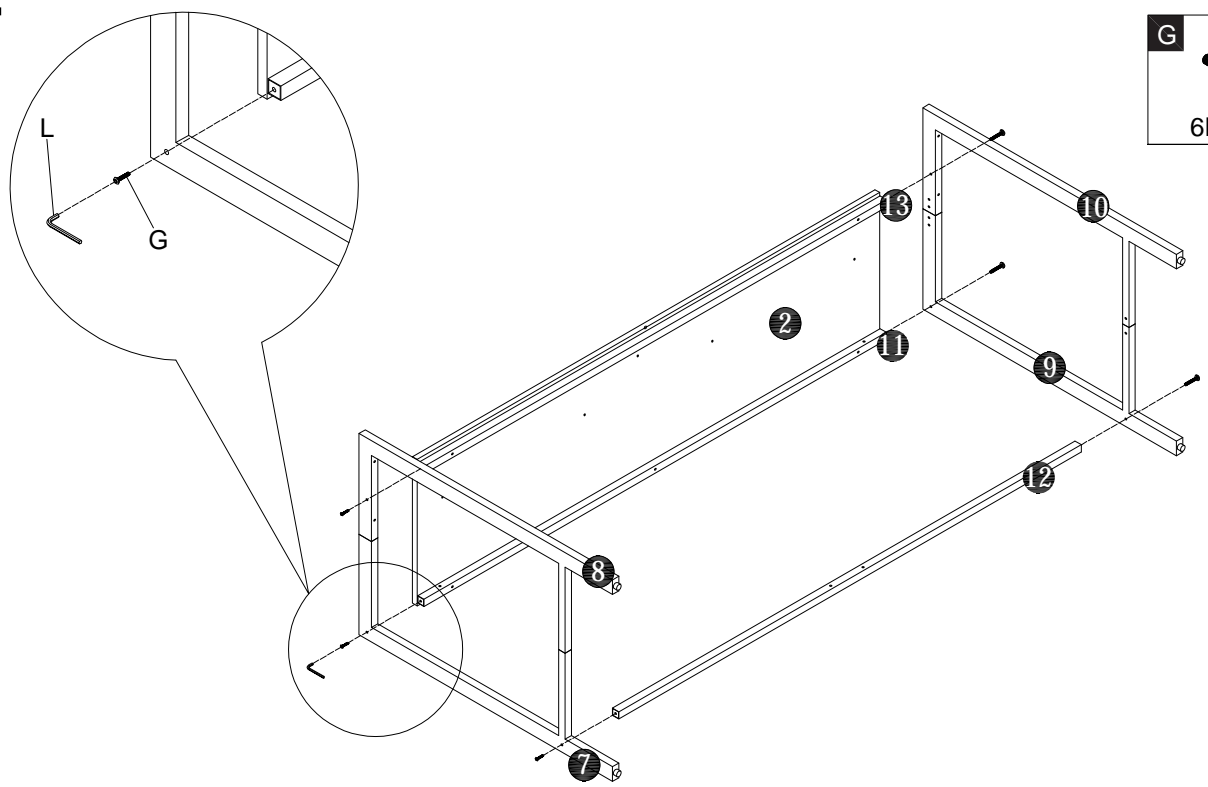

- 12 x1PC
- G 6PCS

5

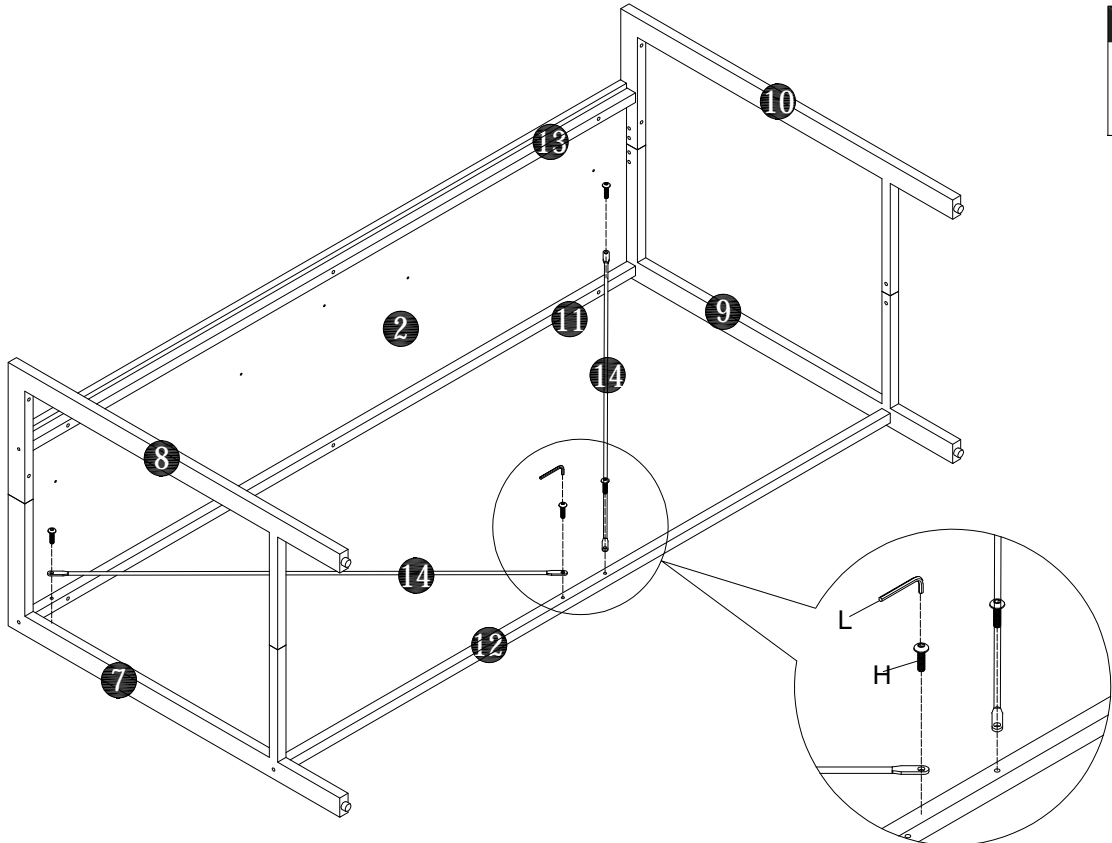

14 x2PCS

H  
4PCS

1 x1PC

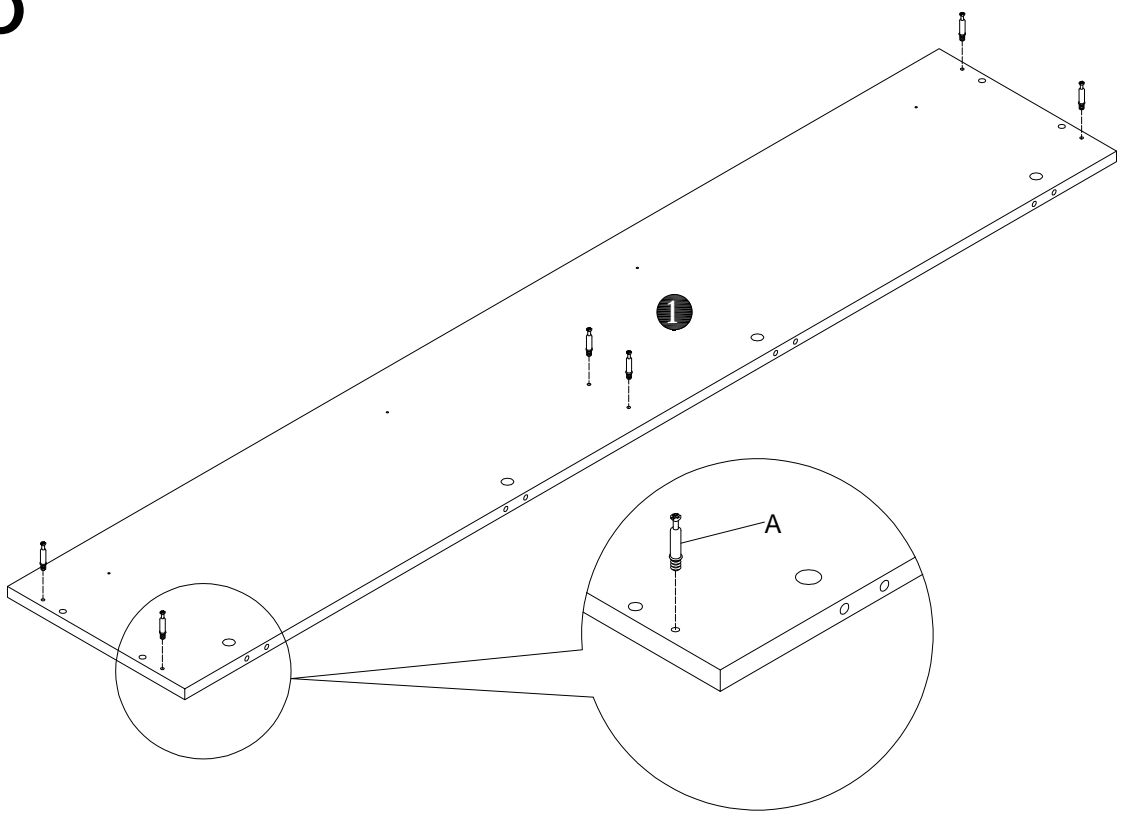

A  
6PCS

6

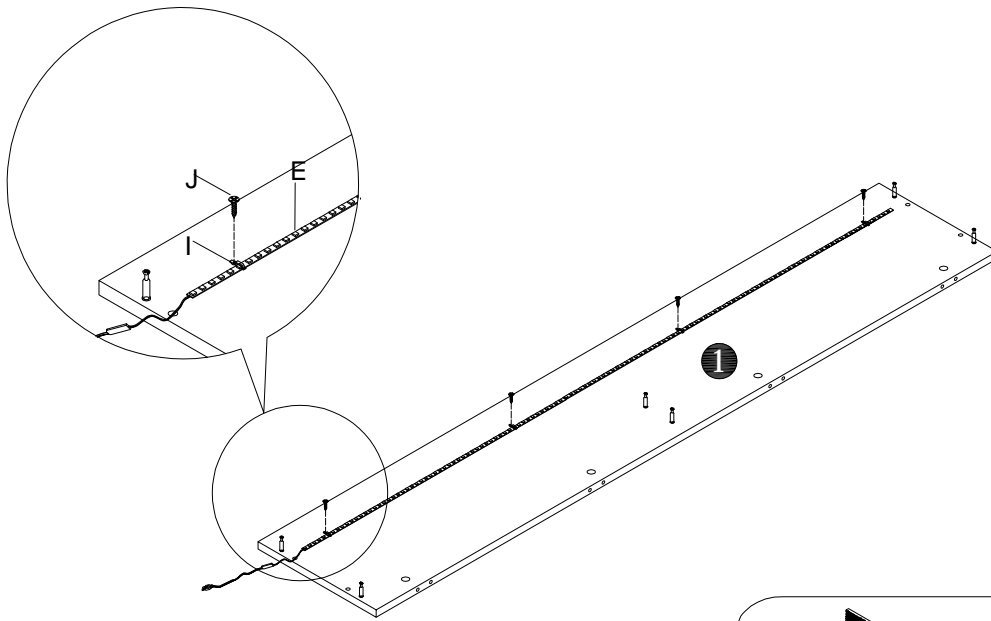

# 7



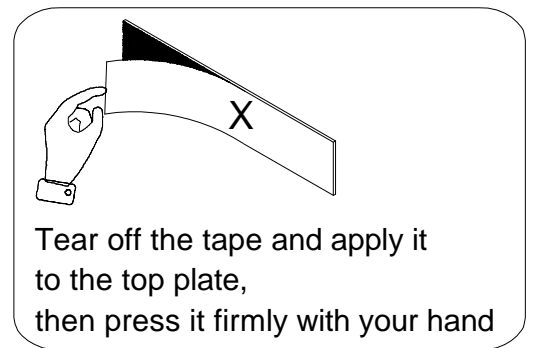

- E**  1PC
- I**  4PCS
- J**  4PCS

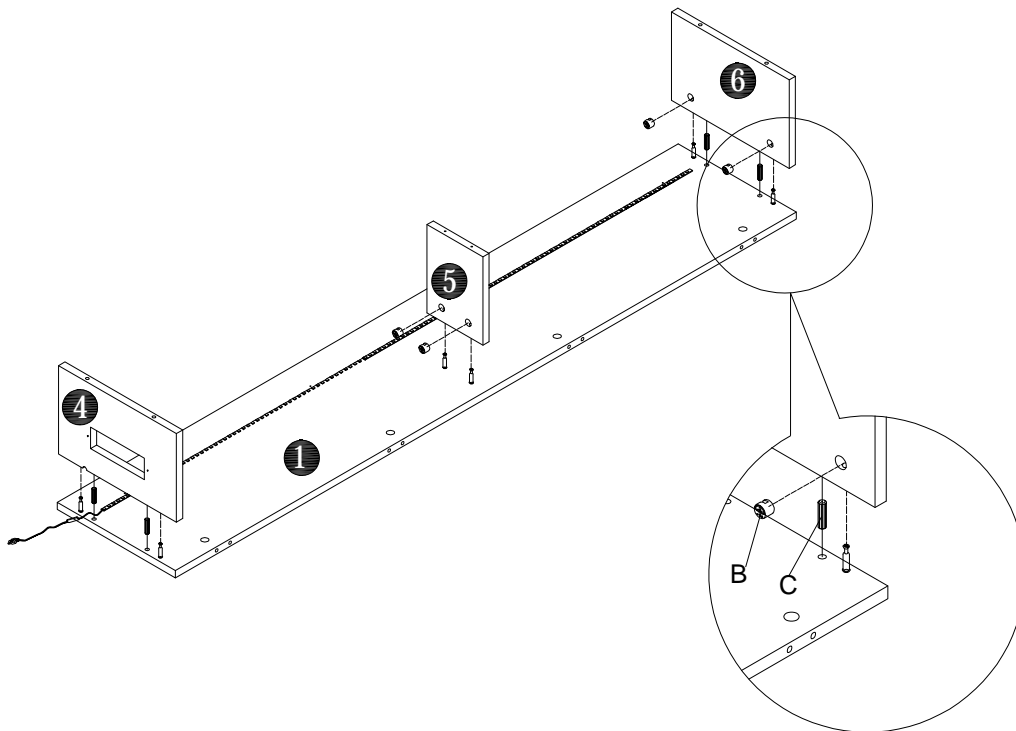

# 8



- 4** x1PC
- 5** x1PC
- 6** x1PC
- B**  6PCS
- C**  4PCS

9

3 x1PC

A  
4PCS

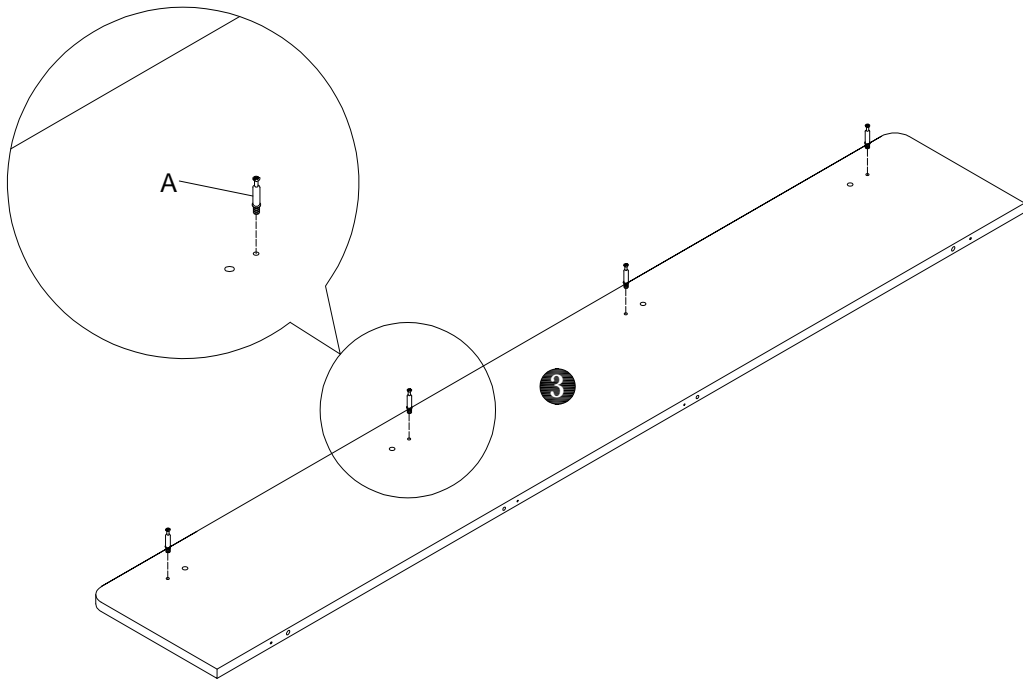

10

B  
4PCS

C  
4PCS

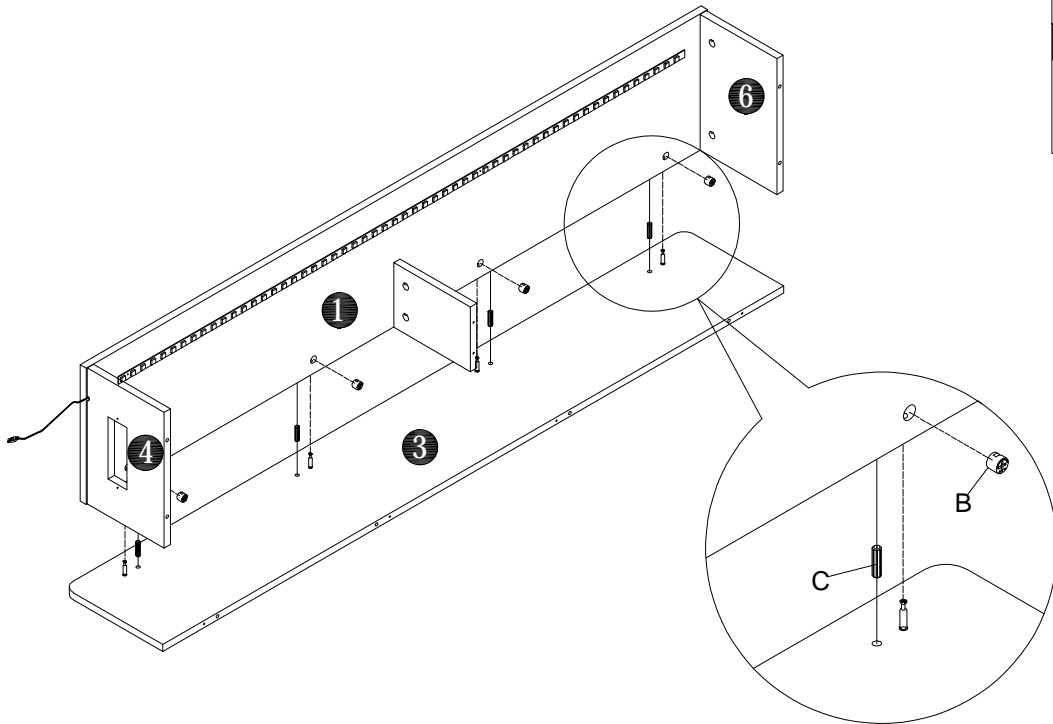

# 11

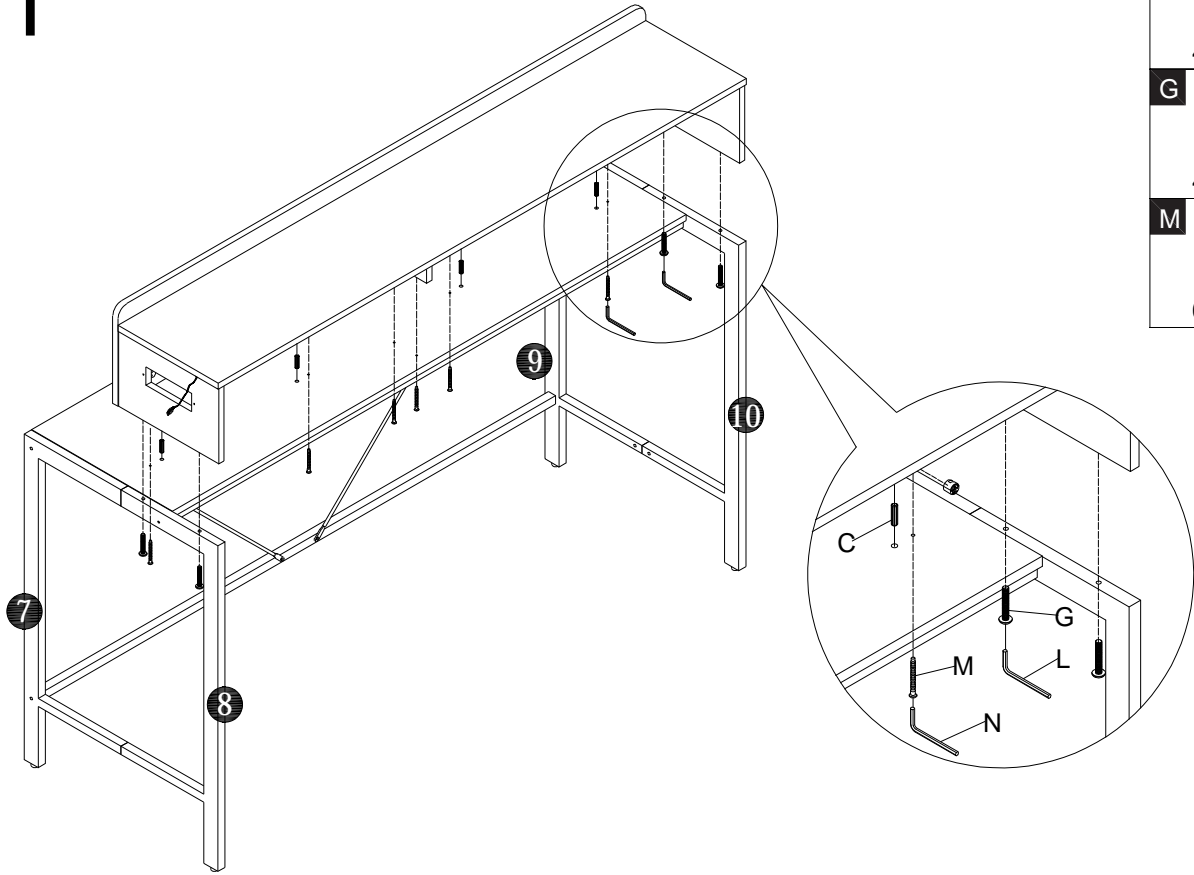

# 12

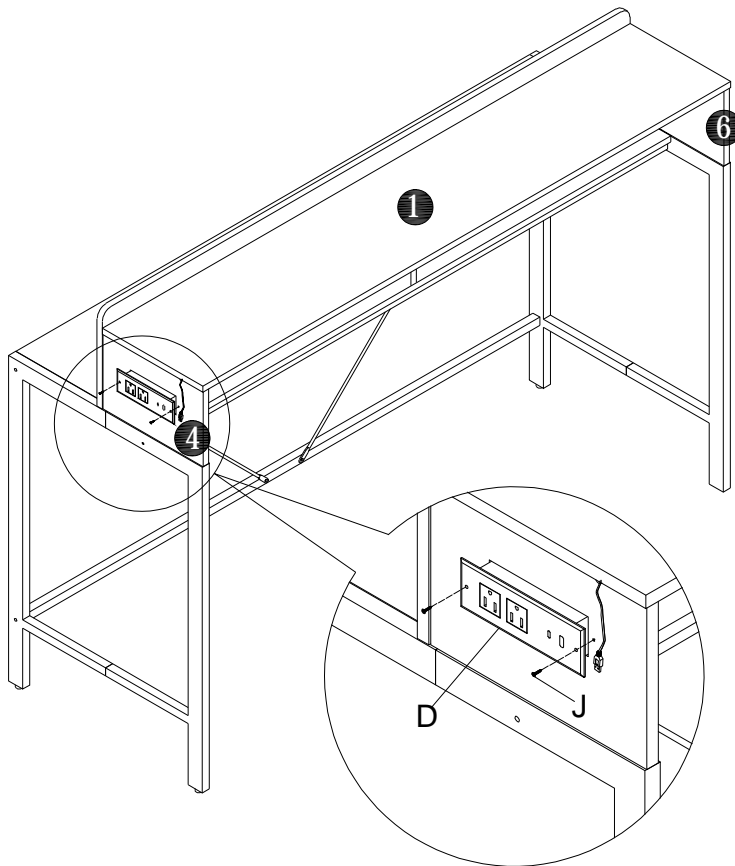

12.

# 13

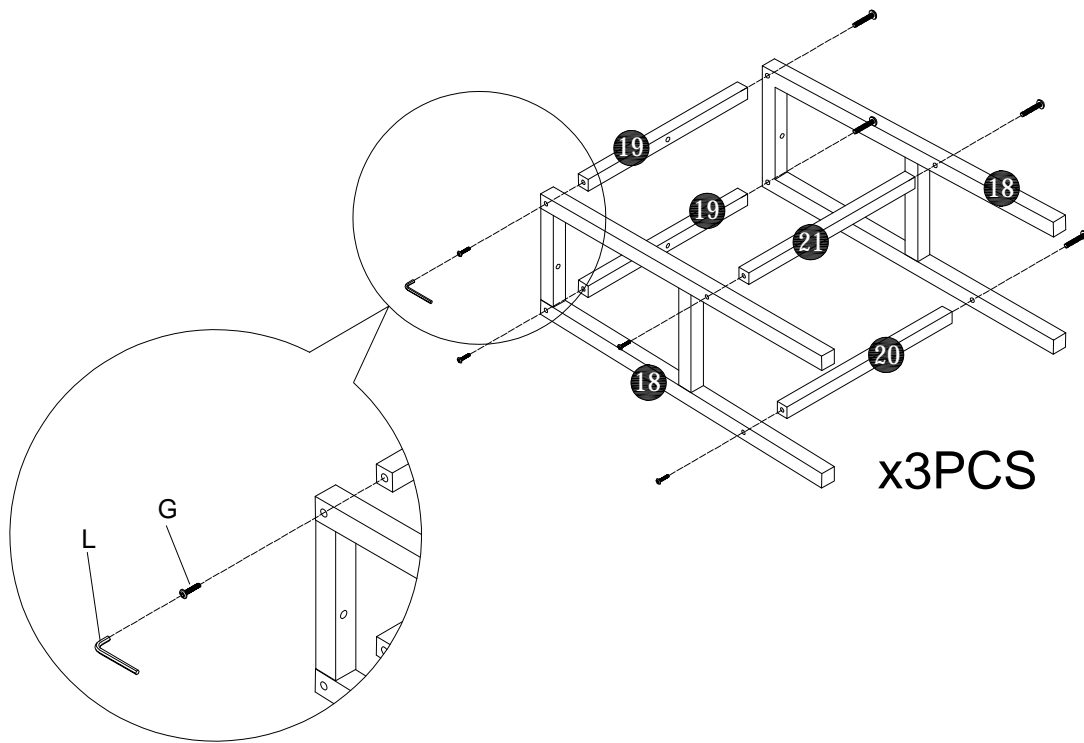

18 x6PCS

19 x6PCS

20 x3PCS

21 x3PCS

G



24PCS

# 14

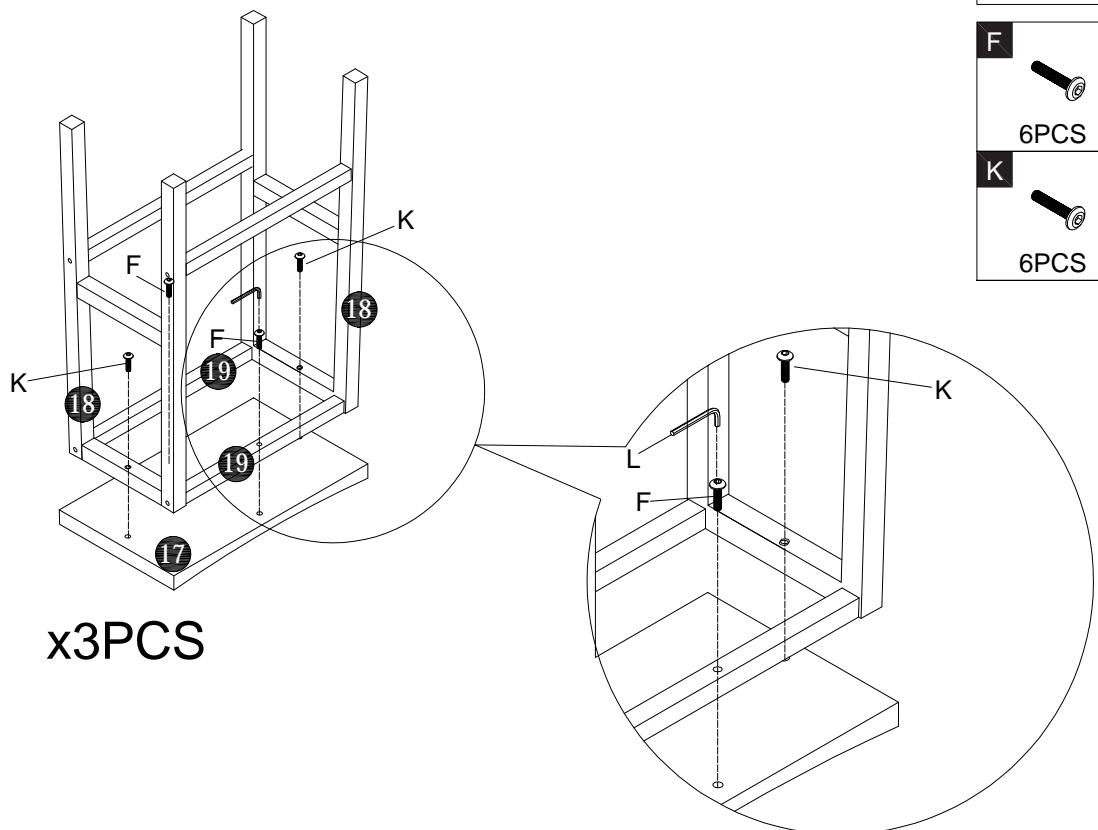

17 x3PCS

F



6PCS

K



6PCS