

# Ceiling fan Installation instructions

- This appliance is for household and indoor use only
- This appliance can be used by children aged from 8 years and above and persons with reduced physical, sensory or mental capabilities or lack of experience and knowledge if they have been given supervision or instruction concerning use of the appliance in a safe way and understand the hazards involved.
- Children shall not play with the appliance. Cleaning and user maintenance shall not be made by children without supervision
- Keep the appliance and its cord out of reach of children less than 8 years
- To protect against electric shock, do not immerse main parts of the product, cord or plug in water or other liquids
- Do not remove the guard for cleaning or maintenance

## Notes on environmental protection

This product may be at the end of his life rather than the normal household waste will be considered at a collection point for the recycling of electrical and electronic equipment will be delivered. The symbol on the product, the instruction manual or packaging recalls.

The materials are recycled, according to their identification. With the reuse of recycling or other forms of recovery of waste afford a important contribution to protect our environment.

Please ask at the municipal disposal of the competent authority.

The light source contained in this luminaire shall only be replaced by the manufacturer or his service agent or a similar qualified person.

## Model No. :DC8554

|                   |          |
|-------------------|----------|
| Voltage           | 220-240V |
| Rated Frequency   | 50Hz     |
| Motor Rated Power | 33W      |
| LIGHT             |          |

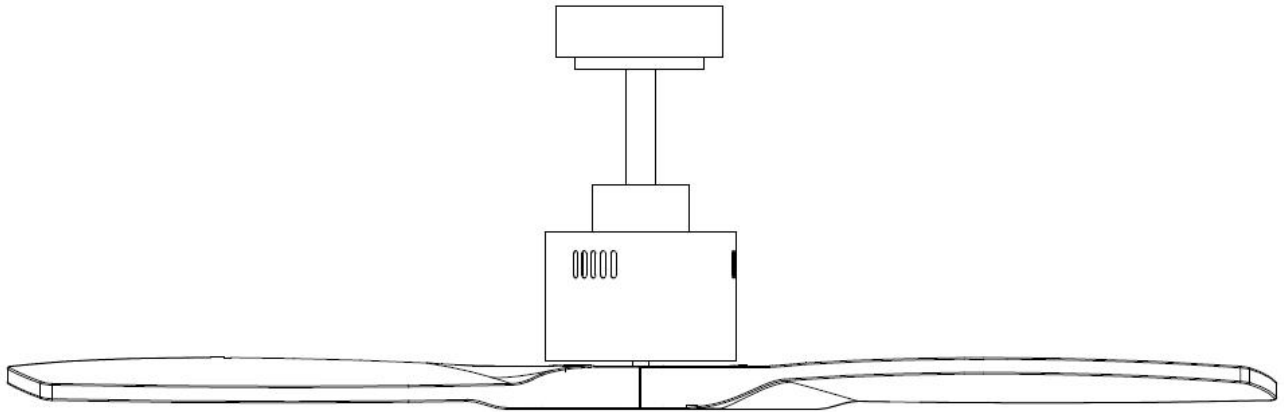

## **Safety Precautions**

- 1. To ensure the success of the installation be sure to read the instructions and study the diagrams thoroughly before commencing.**
- 2. All electrical work should only be undertaken after disconnection of the power by removing fuses or turning off the circuit breaker to ensure all pole isolation of the electrical supply. If you are in any doubt the services of a qualified electrician should be sought to ensure that all work is carried out in accordance with the I.E.E. Regulations, current good practice and other national and local electrical codes.**
- 3. Make sure that your installation site will not allow the rotating fan blades to come into contact with any object and that there is a minimum clearance of 150mm (6") from the blade tip to the wall or ceiling. Please note that the bigger this clearance is the better the airflow from your fan will be. Ensure the blades are mounted at a minimum height of 2.3 meters (7'6") from the floor when the fan is installed.**
- 4. The fixing point for the fan must be able to support a weight of ten times that of the net weight of the fan. Net weights can be found on the bottom of the unit's box. If you are mounting the fan to a ceiling junction box, the box and its fixing must be able to support the moving weight of the fan and must not twist or work loose.**
- 5. The fan must be earthed.**
- 6. Do not connect the fan motor to a dimmer switch. This may give an unsatisfactory performance (motor hum) and cause damage to the motor.**
- 7. It is not recommended that ceiling fans and gas appliances are operated in the same room at the same time.**
- 8. The fan must be turned off and stopped completely before reversing the fan direction. This will prevent any damage to the motor of the unit or controller (if installed).**
- 9. Do not insert anything into the fan blades while the fan is operating. This will damage the blades and upset the balance of the unit causing the unit to wobble.**
- 10. After the fan is completely installed make sure that all connections are secure and tight to prevent any problems.**
- 11. Because of the fan's natural movement, some connections may loosen. Check the support connections, brackets and blade attachments twice a year to make sure they are all secure. If they are loose tighten with a screwdriver. ( It is not necessary to take the fan down from the ceiling)**

**Note :** The important safeguards and instructions given in this manual are not meant to cover all possible conditions and situations that may occur. It must be understood that common sense, caution and care are factors which cannot be built into any product. These factors must be supplied by the persons caring for and using the unit.

**For installation advice or in the unlikely event of damaged or missing parts please ring:**

## Supplied Parts

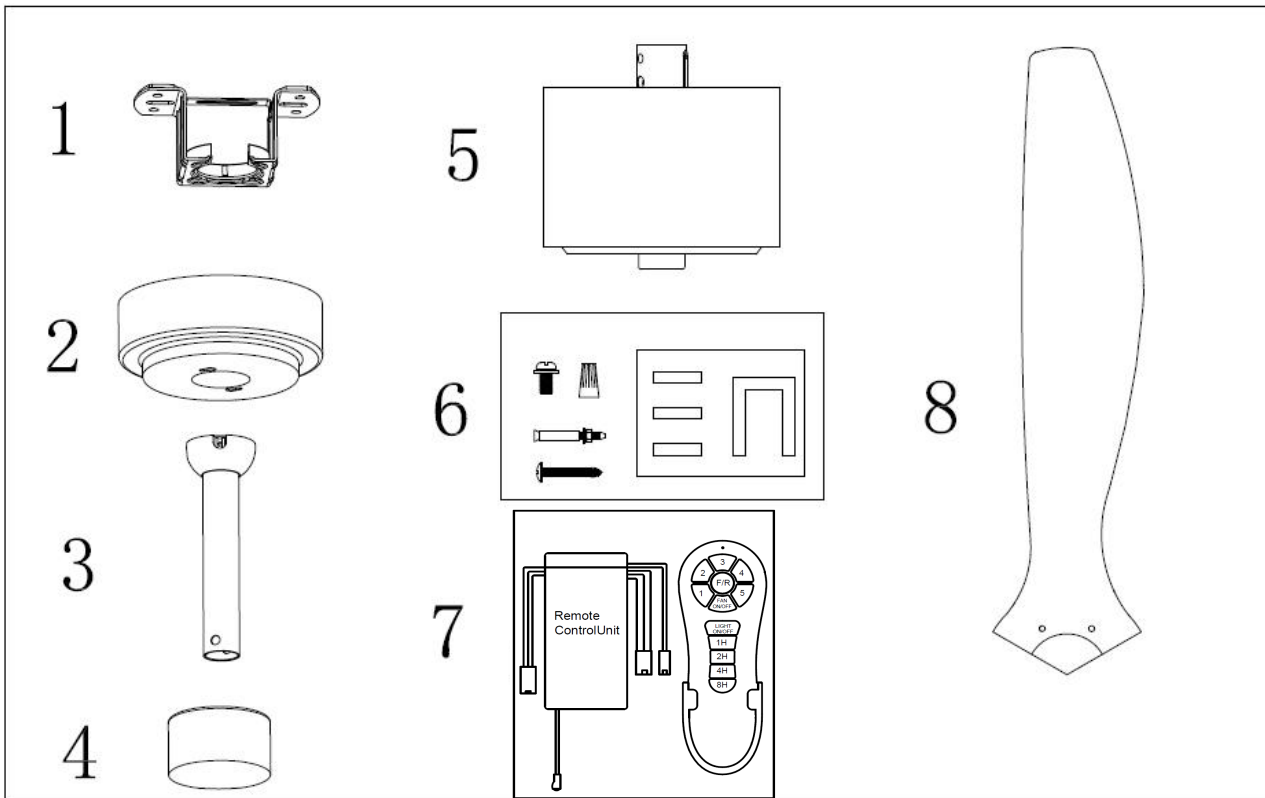

1. **Mounting Bracket**
2. **Ceiling Canopy**
3. **Down rod /Ball Assembly**
4. **Yoke Cover**
5. **Fan Housing , and motor**
6. **Screw Package**
  - A) **Mounting bracket hardware (wire nuts , rubberwashers)**
  - B) **Blade arm attachmenthardware**
7. **Remote Control Unit**
8. **Blades**

## Tools and Materials Required

- I **Philipsscrewdriver**
- I **Bladescrewdriver**
- I **Small electricalscrewdriver**
- I **Electrical pliers**
- I **Step ladder**
- I **Wiring supplies as required by current electricalpractice**
- I **Bulbsifalightfittingisfitted/ tobefitted**
- I **In-linecrimpsorothersuitableconnectorsifan extension rodin excess of760mm(30inch)istobefitted.**

**Before starting the assembly and installation of your fan please ensure the safety precautions have been read and understood.**

## Installing the fan

All electrical work should only be undertaken after disconnection of the power by removing fuses or turning off the circuit breaker to ensure all pole isolation of the electrical supply.

Your fan is a drop rod fan (Picture A) in this situation the drop rod assembly is used to lower the fan down from it's mounting position slightly. Extension rods, ranging from 12" to 72", are available if you need to lower your fan further. (This is normally the case in conservatories or rooms with very high ceilings.)

The following steps will guide you to a successful installation:

1. Hanger bracket installation
2. Installing drop rod and canopy
3. Hanging fan to bracket and attaching the blades.
4. Remote control and Wiring instruction
5. Installing light kit
6. Installing shade

### 1. Hanger bracket installation

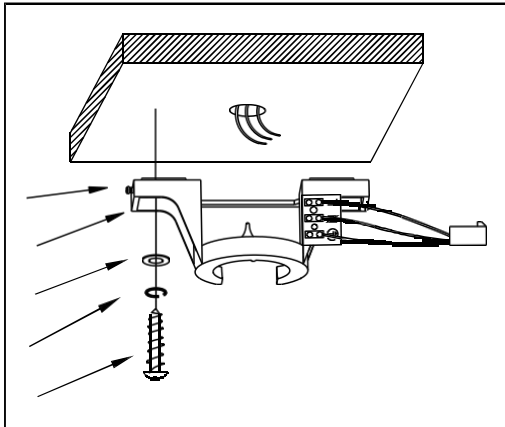

The hanger bracket should be screwed on to a firm flat surface. The fixing location must be able to withstand ten times the static weight of the fan. If you have any doubts as to the ability of your intended fixing location to be able to withstand this loading. Please contact our service helpline or another competent authority to advise you. In most situations two wood screws screwed into a wooden joist is more than adequate to support your ceiling fan.

The hanger bracket should be screwed onto the joist with the two wood screws provided. The washers provided should go in the following sequence:

Screw head > round washer > spring washer > Hanger bracket > Ceiling. Screw the hanger bracket to the ceiling and make sure all connections are secure to prevent the fan from falling. Fixings must screw into a joist and not just the plasterboard. Loosen the two canopy screws from the hanger bracket.

## 2. Installing canopy and drop rod onto the fan

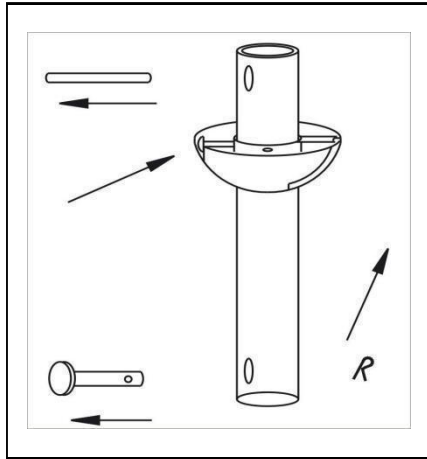

Unscrew the screw on the drop rod hanger ball, then loosen the hanger ball. A "BALL PIN" will be seen on the drop rod, remove it and the hanger ball from the rod.

Remove the cotter pin and split pin from the drop rod boss of the fan. If a longer drop rod (12" to 72" rod) is going to be used transfer the ball joint and the earth wire to the longer rod.

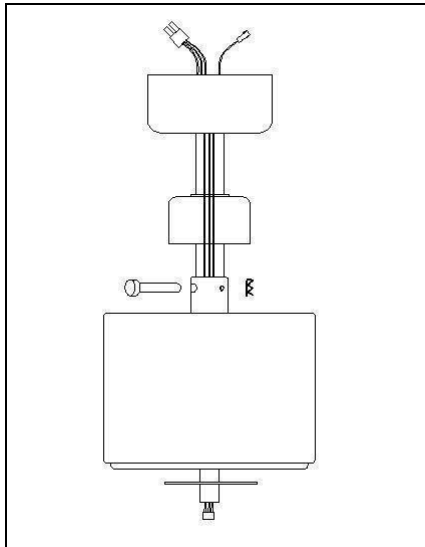

Put the drop rod pass the electrical supply leads from the top of the motor through the drop rod until they exit at the top of the rod.

Insert the drop rod into the drop rod boss on top of the motor casing. Turn gently to align the holes in the boss with those in the rod. Ease the bolt pin through the boss and the rod taking care not to pinch or damage any cables. Fix in place by replacing the R pin.

Tighten all set screws at this point. This prevents the rod and the fan moving in relation to one and other. It also assists in maintaining a good earth continuity through the fan, which is important to the safety of the unit.

Failure to tighten the locking screws down may cause the motor to oscillate badly

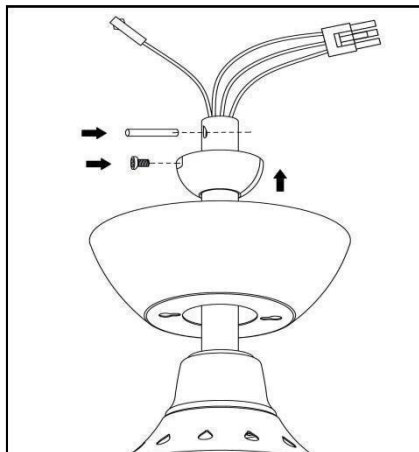

The above steps are all finished, put the hanger ball onto the drop rod, inserted the BALL PIN into drop rod, lift up the hanger ball. Then, screw them down firmly

### 3. Hanging the fan to bracket and installing blade

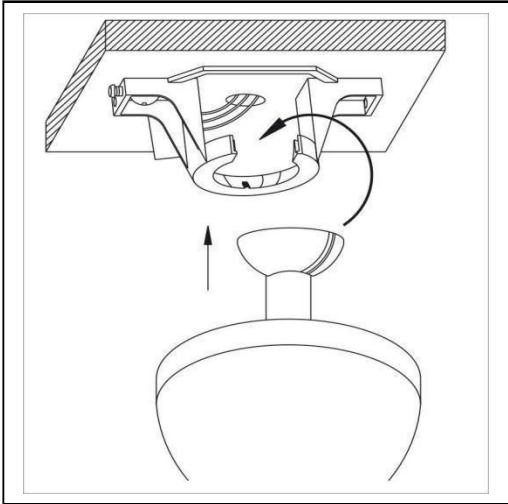

Lift the fan up to the hanger bracket, steer the ball in from the side of the bracket and lower it into the recess of the bracket. Rotate the ball around until the groove in the side of the ball aligns with the protrusion on the upper edge of the recess. When aligned the fan should drop slightly as it assumes it's correct position. This is to prevent rotation of the rod and fan when the unit is working

Putting the plastic blade and align the hole on the surface of motor. Using the motor screw and the spring washers provided, bolt the plastic blade onto the motor. Ensure the bolts are tightened firmly.

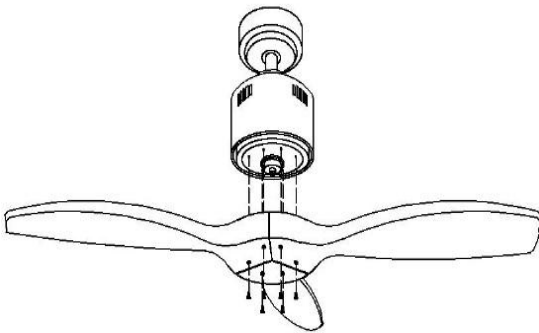

Be careful not to bend the blades during installation as this may result in an imbalance and induce wobble.

If installing more than one fan be careful not to mix the blade sets. Each set is carefully manufactured to be evenly balanced, mixing would break up a balanced set and again this could induce wobble.

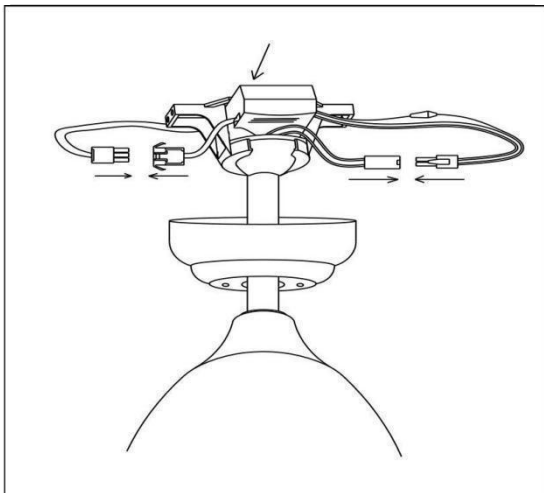

After set up the code switch, put the receiver through the hanging bracket for wiring connecting

Connect the PUSH CONNECTOR of fan to Remote control, please be noted, the wire position need to be **"BROWN to BROWN, BLUE to BLUE, ORG to ORG, GREE/YELLOW TO GREEN/YELLOW"**.THE PUSH CONNECTOR COULD NOT BE PUSHED IN AND WILL CAUSE FAN DAMAGE IF THE WIRE POSITION IS WRONG.

Connect the PUSH CONNECTOR of hanging bracket to A.C. input power of remote control. **"BROWN to BROWN, BLUE to BLUE, GREE/YELLOW TO GREEN/YELLOW"**.

# Remote control and Wiring instructions

## **WIRING INSTRUCTIONS : Before doing wiring, ensure that you have all pole disconnection of the electricity supply.**

Your fan is supplied with a radio frequency remote control unit, and the fan does not have a pull switch for speed control, the fan can only be controlled by remote control. You can find the unit in the box.

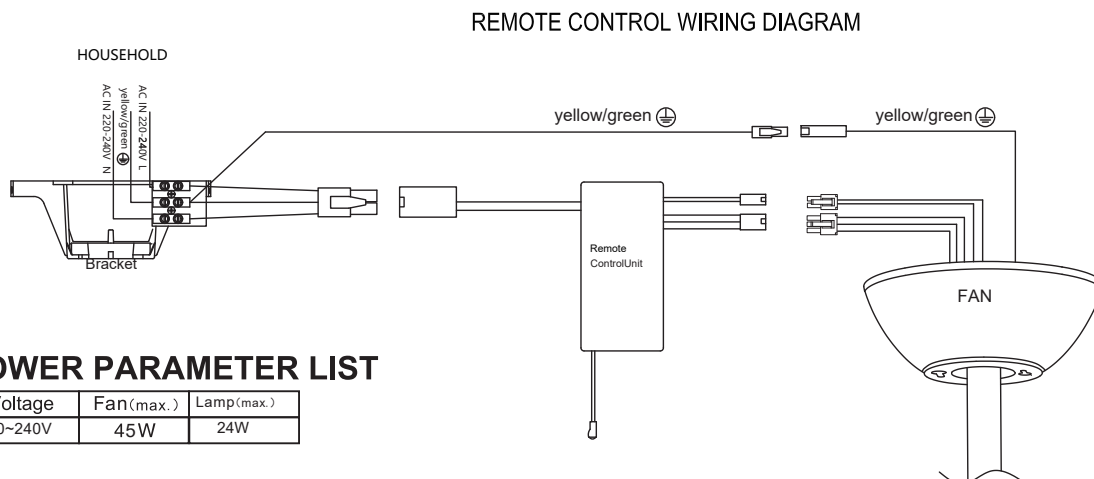

Adopt RF wireless digit emission technique, biunique controlled , coincident code rate is less than one millionth.(Emitter and receiver must be sent back to factory for maintenance if damaged.)

Receiver can be controlled by any angles of the emitter in prescriptive space, unrestricted by direction. With the memory function, the controller can save the status( light and direction ) while the supply power OFF and resume to the original after reload the power supply.

## FUNCTION INSTRUCTION OF EMITTER

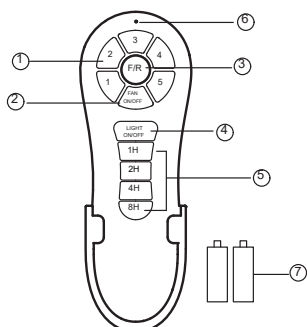

- ① Speed of the fan (①low speed ----⑤high speed)
- ② ON/OFF the fan
- ③ Direction of the fan (reverse switch)
- ④ ON/OFF the light
- ⑤ Timing control of the fan
- ⑥ LED indicated light
- ⑦ 1.5V\*2 battery should be used in emitter

## KINDLY REMINDERS:

1. Learning code matching mode is used between emitter and receiver. Turn "ON" the supply power within 30 seconds and press the emitter's "FAN ON/OFF" button for 5 seconds, it can load normally after hearing a long sound "bee", which means learning successfully and it can works normally. (PS: Learning mode is not accepted after turn "ON" the supply power for 30 seconds)
2. When the emitter cannot control the receiver, please check the battery switch touching normally or not, correction of the positive and negative, full or empty of the power.
3. When the emitter cannot control the receiver, please check is there any existence of similar remote controlled products nearby, then check whether they works, because remote controlled product with the same frequency will disturb each other.
4. Low voltage of battery will affect the sensitivity of the emitter and the signal reception accordingly(the indicated light will flash out its warning when the battery get low voltage),must replace if the battery is getting low voltage.
5. Please take out the battery from the emitter when leaving unused for long time.
6. The maximum load of lighting see the above"POWER PARAMETER LIST"  
**PS: please connect the ground wire correctly, otherwise it may cause the light micro-light or flash**
7. When installing the fan,the fan ceiling cover don't press the antenna(or other wire),it is easy to breakdown the wire and short-circuited.

## NOTE:

1. Please allow a moment between each operation.
2. Please handle the transmitter with care, be sure not to drop or expose it to water, high humidity or place where is too close to a heating element. Improper handling may result in malfunction and void the warranty.
3. The remote control is operated by Radio Frequency, so, it won't be Necessary to point this unit at the ceiling fan while activating the Handset functional button.

## DYNAMIC BLADE BALANCING KIT

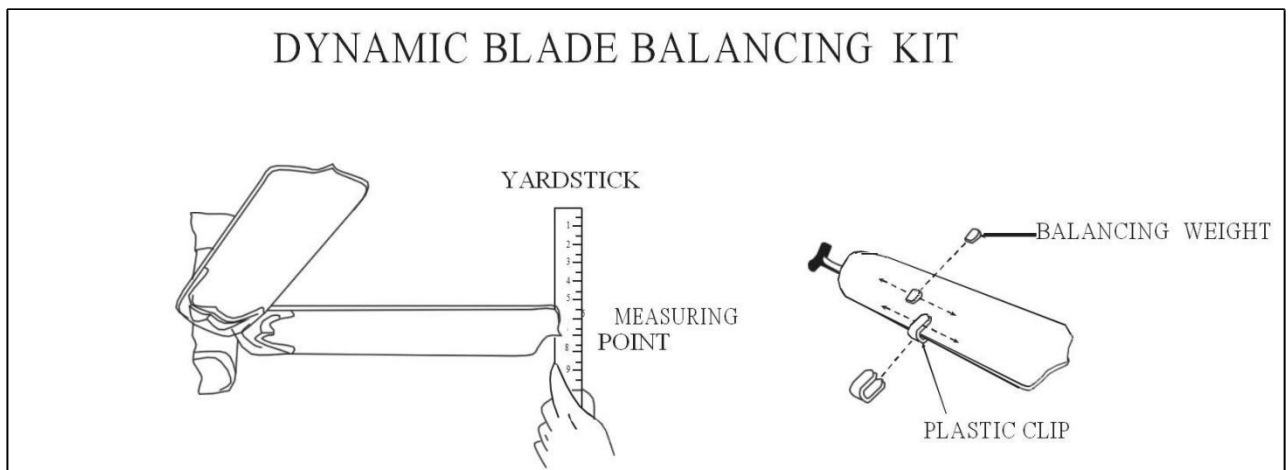

### PREFACE

Your ceiling fan may sometimes have wobbling problems when operating due to irregularity in the blades or the blade holders. Also, improper assembly in the mounting system or crooked bearings may cause some additional problems. This balancing kit can be used to fix wobbling problems.

### DYNAMIC BLADE BALANCING KIT FOR CEILING FANS

1. Make certain that all blades are firmly screwed into the blade holder.
2. Make sure that all blade holders are firmly secured to the motor housing and check that the pitch of blade holders are all the same.
3. By looking up at the fan from below, check and be certain that none of the blade holders are bent and that none of the blades are out of position. A correction can be made by very gently bending the blade holder back into position.
4. Use a yardstick to check the blade tracking. Put the yardstick up against the ceiling vertically and against the outside leading edge of a blade. Note the distance of the edge of blade to the ceiling. Carefully turn the blades slowly by hand to check the remaining blades. If the blade is not in alignment, the blade holder may be gently bent up or down to be in line with the other blades.

After following all the steps and if the wobbling problem is not solved, a dynamic balancing needs to be done by balancing kit. Follow the procedure listed below:

- Turn the fan on and adjust the speed control (usually high speed) setting to the speed which creates the greatest wobble.
- Turn the fan off. Select one blade and place the balance clip on it, halfway between the blade holder and the blade tip on the rear edge of the blade.
- Turn the fan on. Watch to see if the wobble is improved or worsened. Turn the fan off again and move the clip to another blade and test again. Repeat this process with all blades and then note the blade which is the most improved.
- Move the clip back to the blade which showed the most improvement. Move the clip inward and outward on this blade and operate the fan to find the position where the clip gives the most improvement.
- Next remove the clip and install a balancing weight to the top of the blade along the center line near the point where the clip was positioned. Use a sharp knife or razor to separate the weights.

Caution: Stay clear of the blades. If the clip, for any reason, is not secure, injury could result

# MAINTENANCE

1. The fan's natural movements may cause some connections to work loose. A clicking or rattling noise is a certain sign of loosening screws. Check the support connections, brackets, and blade attachments twice a year, and tighten all screws as necessary. Make sure all screws attaching the glass to the fitter on the light kit is finger tight. Do not use a screw driver or pliers to tighten the glass screws.
2. Clean your fan periodically. Use only a cloth or brush. Metal finishes are finished with a lacquer to prevent tarnishing.
3. You will never need to oil your fan. Its permanently sealed bearings will provide silent, trouble free operation for many years.
4. Make sure the power is turned off at the main fuse or circuit panel before you attempt any repairs.

# TROUBLESHOOTING

## **FAN WILL NOT START:**

1. Check all fuses or circuit breakers. Replace if missing.
2. Turn off electrical power and check all check all wire connections to fan and in switch housing.

## **FAN IS NOISY:**

1. Always allow a few days "break in" time for any new fan at medium or high speed. Try to diagnose the exact location of the noise by listening carefully from several sides (blades, motor, light kit, etc.) Fan noise can come from a light kit.
2. Make sure all screws in the fan assembly and light kit are tight and properly threaded. If not, back out and re-tighten. Tighten these screws at least once a year because they may loosen slowly over time and cause a clicking noise.
3. Make sure the light kit is securely fastened to the fan, and all glass screws are finger tightened only.  
Do not tighten with pliers or a screw driver.
4. Make sure mounting bracket is installed snugly to junction box.
5. Make sure wire nuts in switch housing or canopy are not rattling against each other or against wall of housing .Wrap with electrical tape if necessary.
6. Use of standard light rheostat or unapproved wall control will always cause harmonic distortions, or a humming noise .Many fan motors do no work quietly with solid state variable controls. If a quiet wall control is desired, use only approved wall controls.
7. Make sure the canopy is not touching the ceiling.
8. Assure that the screws fastening the blade holders to the motor are tight and the lock washers provided for that purpose have been used.
9. Make sure all light bulbs are fully screwed in.

## **FAN TURNS BUT DOES NOT MOVE MUCH AIR:**

1. The fan may be running in reverse, so air is directed upward.
2. The room may contain items that obstruct the airflow.
3. The fan may be too small for small for size of the room.

## FAN SHAKES OR WOBBLER:

1 A small amount of wobble is considered acceptable and should not be considered a defect. Use of

Any light kit, especially a large 4 or 5 light kit will usually induce some wobble.

2. Make sure the mounting bracket is tight at junction box/ceiling with no movement at all. Tighten screws if necessary.
3. Make sure all screws holding the blades to the blade arm and blade arm to motor are tight. Make sure light kit/glass screws are tight.
4. Some fan movement is normal. However, interchanging an adjacent (side-by-side) blade pair may redistribute the weight and result in smoother operation.
5. If a balancing kit is provided, use it if needed.



Meaning of crossed-out wheeled dustbin:

Do not dispose of electrical appliances as unsorted municipal waste, use separate collection facilities. Contact your local government for information regarding the collection systems available. If electrical appliances are disposed of in landfills or dumps, hazardous substances can leak into the groundwater and get into the food chain, damaging your health and well-being.



Die Bedeutung der durchgestrichenen Mülltonne:

Entsorgen Sie elektrische Geräte nicht im Hausmüll, nutzen Sie die Sammelstellen in ihrer Gemeinde. Fragen Sie Ihre Gemeindeverwaltung nach den Standorten der Sammelstellen. Wenn elektrische Geräte unkontrolliert entsorgt werden, können während der Verwitterung gefährliche Stoffe ins Grundwasser und damit in die Nahrungskette gelangen, oder Flora und Fauna auf Jahre vergiftet werden.