

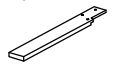





ASSEMBLY INSTRUCTIONS

QUEEN BED





(Box 1) BOX OF HEADBOARD & HB LEG

| No | ITEM | Qty |
|----|---|-------|
| A | Headboard  | 1 pc |
| B | Headboard Leg (L/R) (500mm)  | 2 pcs |



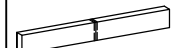

(Box 1) BOX OF HEADBOARD & HB LEG

| No | ITEM | Qty |
|----|--|-------|
| 1 | JCBC Bolt M6 x 30mm  | 6 pcs |
| 2 | Spring Washer 1/4" Rbw  | 6 pcs |
| 3 | Flat Washer 1/4" ID x 13mmOD Blk  | 6 pcs |
| 4 | Allen Key M6 x 65mm  | 1 pc |
| 5 | 12V+12W+1A Adaptor  | 1 pc |

(Box 2) BOX OF SIDE RAIL

| No | ITEM | Qty |
|----|--|-------|
| C | Bed Slat  | 4 pc |
| D | Bed Slat Support with leveler  | 4 pcs |
| E | Side Rail  | 2 pcs |
| F | Footboard Leg  | 2 pcs |
| G | Footboard  | 1 pc |

(Box 2) BOX OF SIDE RAIL

| No | ITEM | Qty |
|----|---|-------|
| 5 | JCBC Bolt M6 x 40mm  | 6 pcs |
| 6 | Allen Key M4 x 65mm  | 1 pc |
| 7 | Allen Key M5 x 65mm  | 1 pc |
| 8 | Flat Head Chipboard Screw M4 x 32mm  | 8 pcs |
| 9 | Flat Head Chipboard Screw M4 x 50mm  | 4 pcs |

STEP 1

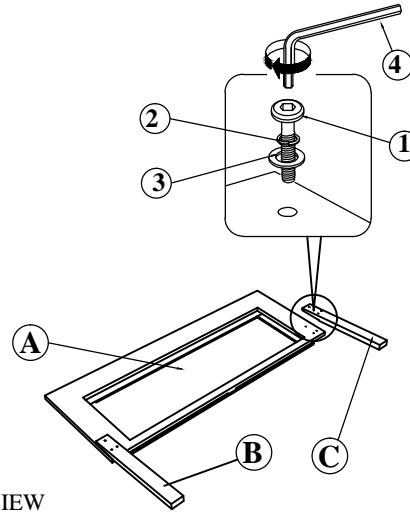

**BACK VIEW

**Please take note the marking on the leg **

STEP 2

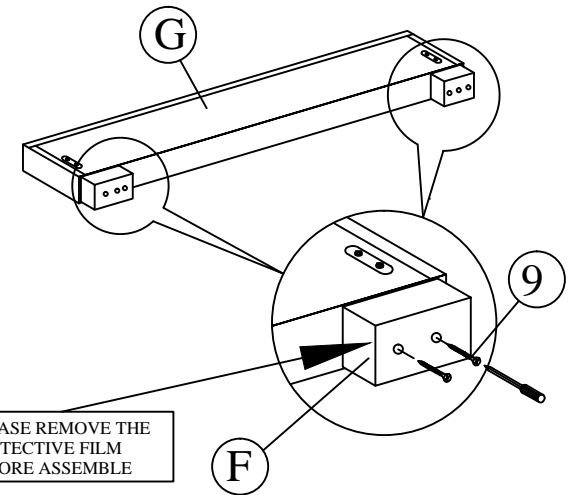

PLEASE REMOVE THE
PROTECTIVE FILM
BEFORE ASSEMBLE

STEP 3

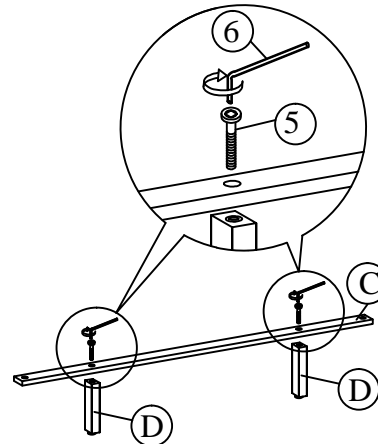

STEP 4

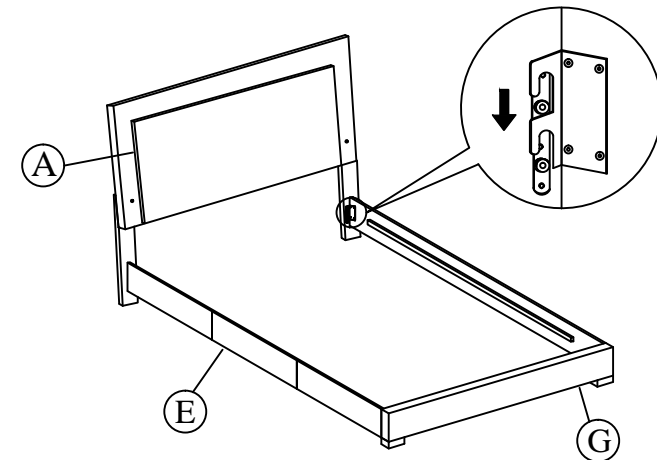

STEP 5

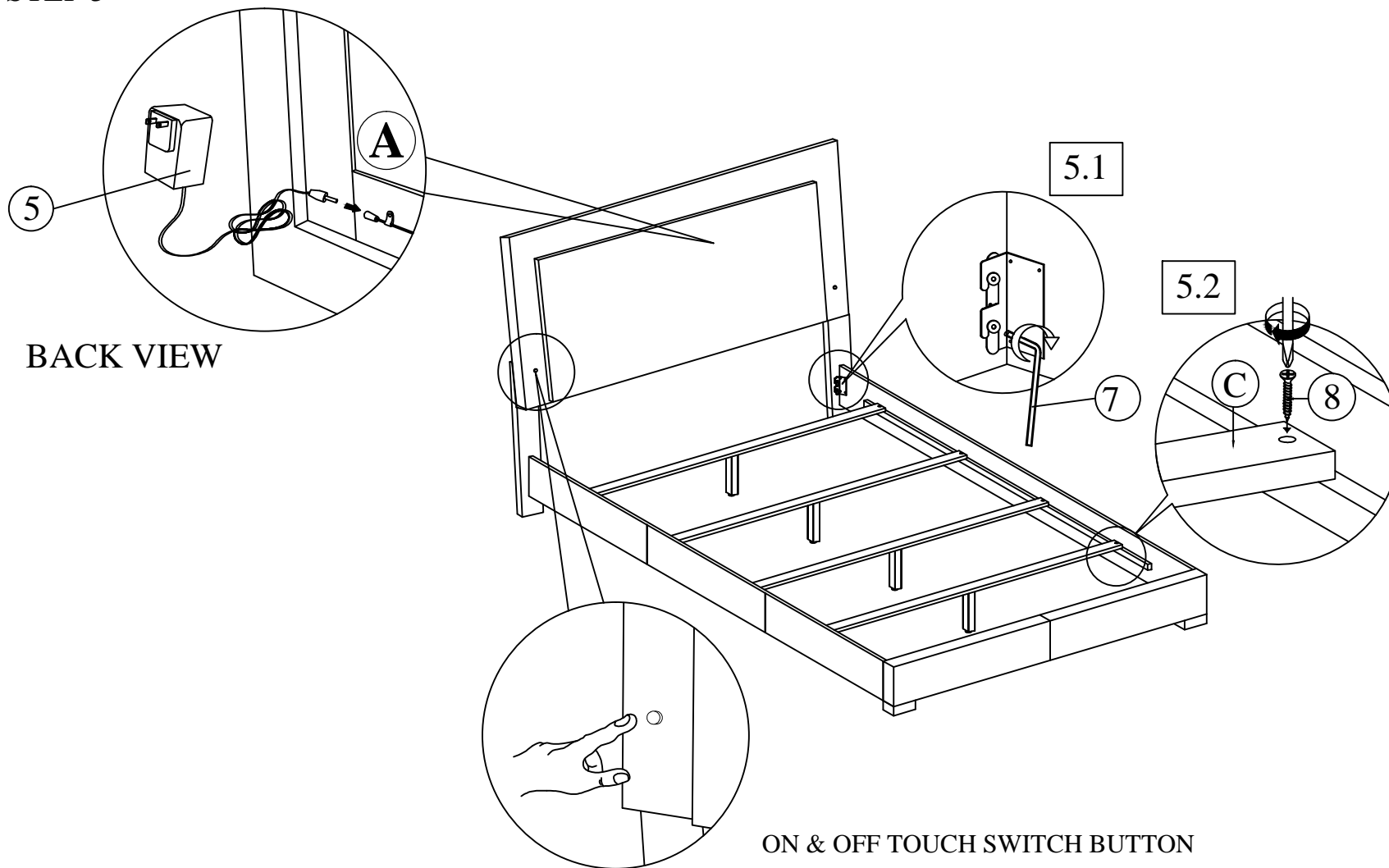

NOTE : MUST TIGHTEN SCREWS PERIODCALLY WITH USE SCREW WILL BECOME LOOSE CHECK TIGHTNESS OF ALL SCREW EVERY 6-8 WEEKS.