

# Assembly Instruction

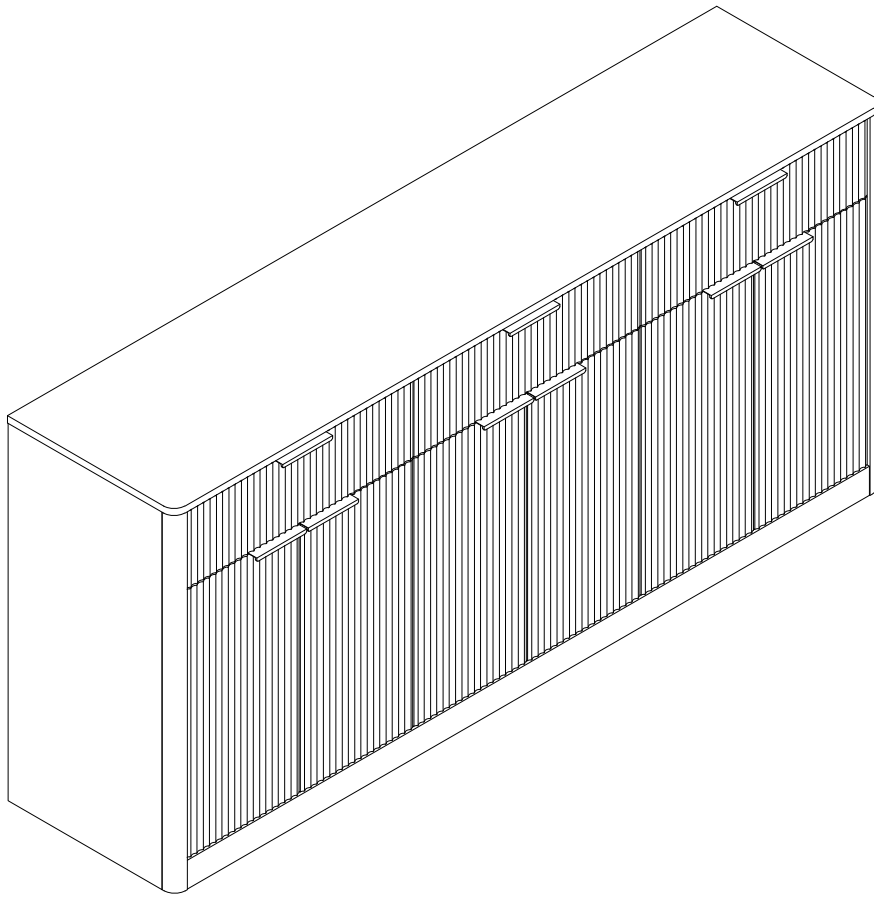

## General Guidelines

- Please read the following instruction carefully and use the product accordingly.
- Please keep this manual and hand it over when you transfer the product.
- This summary may not include every detail of all variations and considered steps. Please contact us when further information and help are needed.

## Notes

- The product is intended for indoor use only. The product must be assembled and used in accordance with the provisions of the manual. Personal injury and/or damage to product may occur if products are used outside of their intended purposes and/or if products have been changed/modified from their original design. The seller does not assume any responsibility or liability with respect to any injury/damage caused by incorrect assembly or improper use.
- Avoid long-term exposure to humid environments to prevent mildew.
- Keep the product away from fire sources and high temperatures. Do not expose the product to direct sunlight.
- Do not place any hot objects on the surface of the product.
- If there are any defective or missing parts after unpacking, please cease assembly immediately and contact us.
- Please assemble the item on a spacious surface and do not place the unwrapped product directly on the ground to avoid product damage.
- Please do not stand or sit on the wooden boards.
- Please wear gloves during the assembly and/or disassembly process to avoid scratches from any sharp edges.
- Please match the corresponding part and fitting based on the part number in the manual.
- If the part does not match with the fitting, please check the piece as specified in this manual.
- During assembly, first loosely align all screws with the corresponding pre-drilled holes and then tighten the screws one by one.
- Periodically inspect screw tightness while the product is in use. If necessary, retighten to ensure structural integrity.
- If you accidentally spill water or another liquid on the surface, immediately wipe clean with a dry towel.
- Please keep the product away from sharp, pointed objects and corrosive substances to prevent product damage.
- Please place this item on level, solid ground during use.

## Warnings

- During assembly, keep all small parts out of the reach of children. It may be fatal if swallowed or inhaled.
- Children should not climb or play on the product in order to avoid tipping over the furniture and causing serious injury.
- To avoid the potential dangers of suffocation, please keep all parts and packaging (film, plastic bags, foam, etc.) away from babies and children.
- Keep sharp objects and corrosive items away from the product to avoid any damage or injury.
- Do not shake or move violently during use to avoid tipping over the product.

# Parts List (EN)

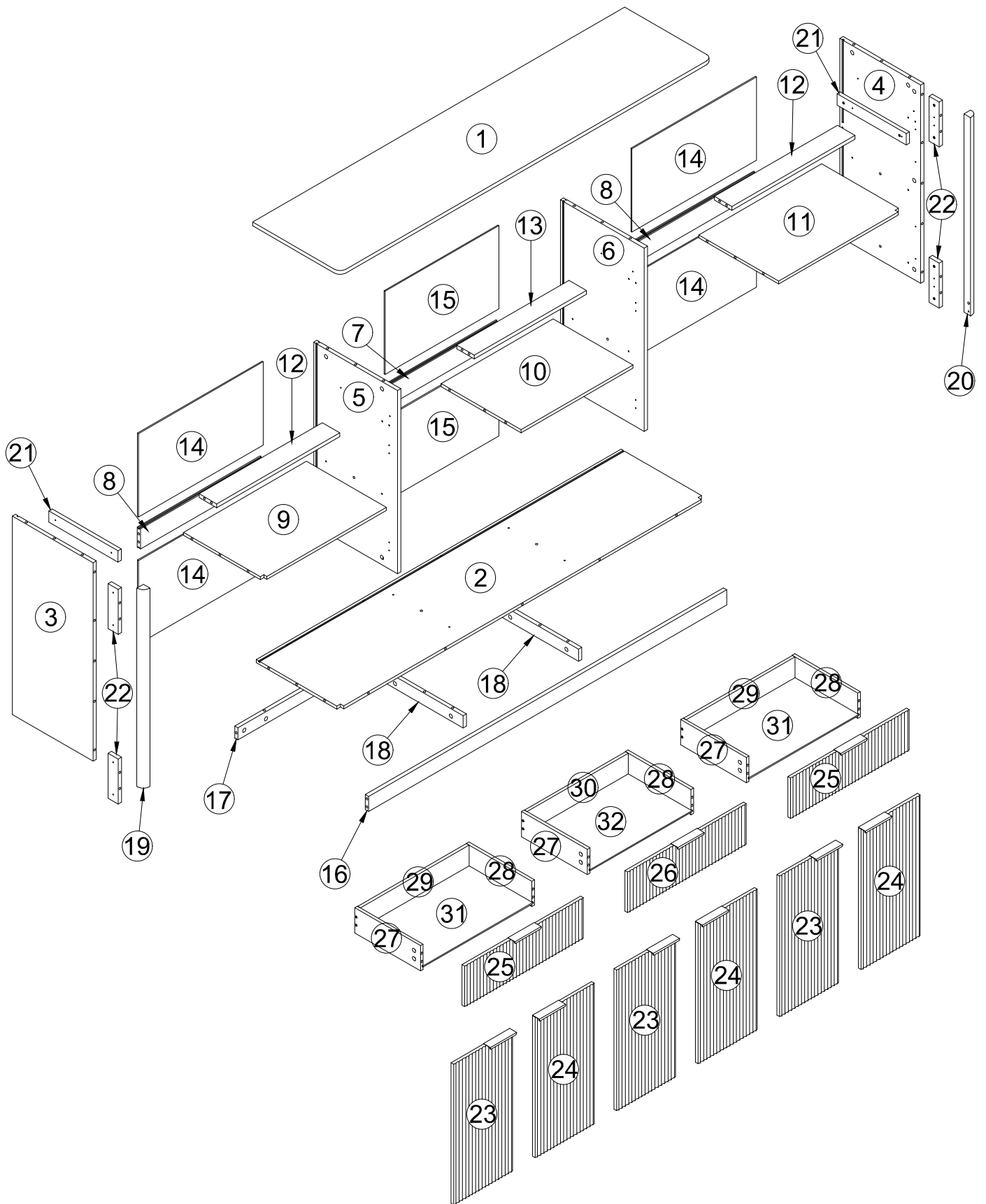

# Parts List (EN)

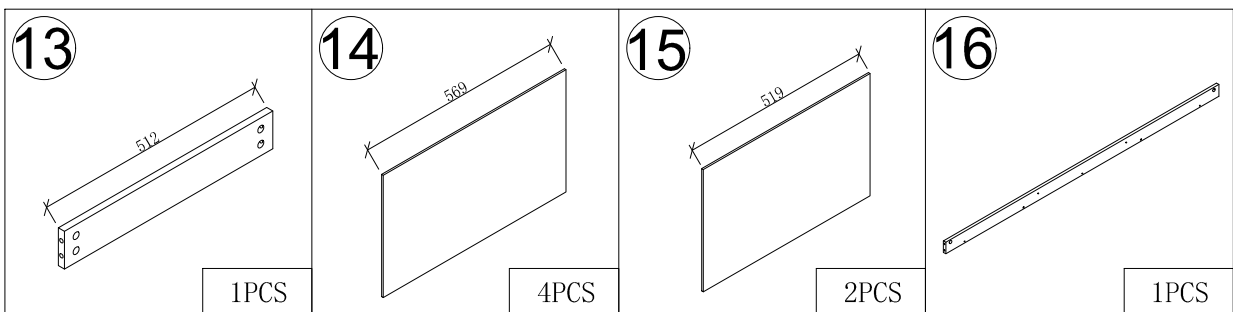
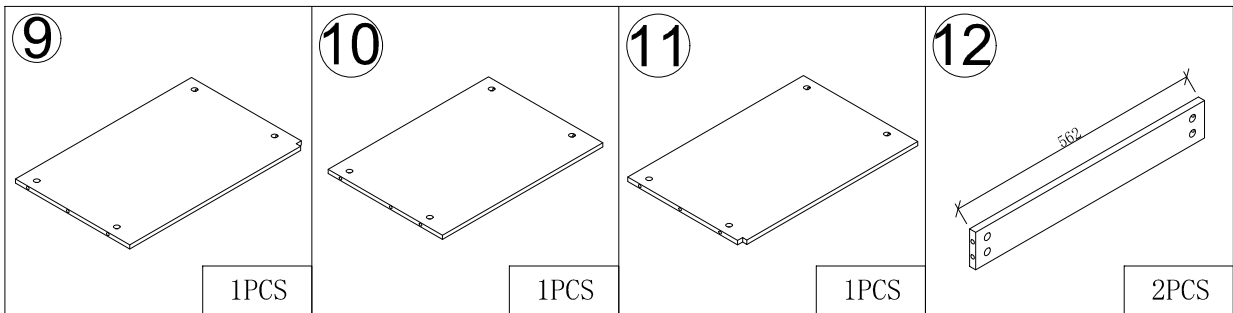
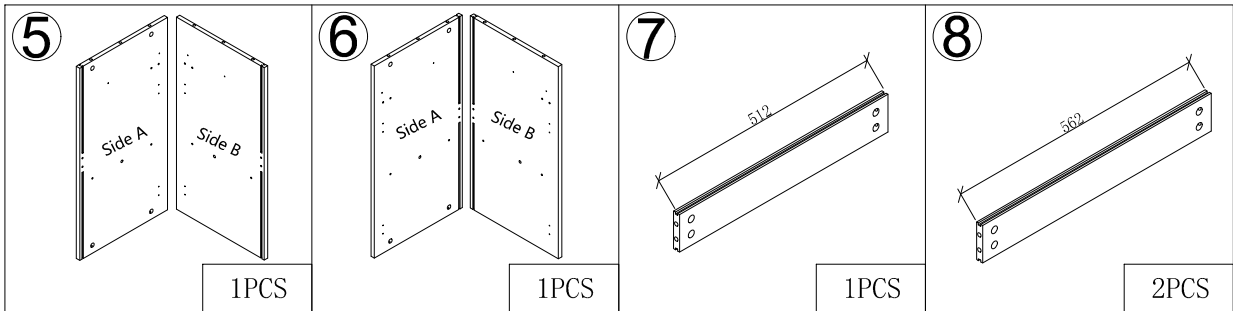
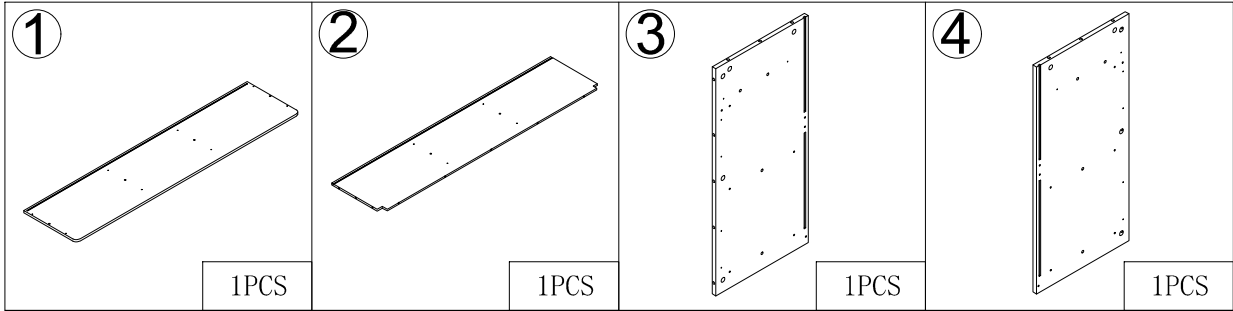
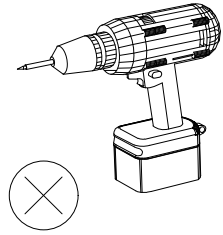
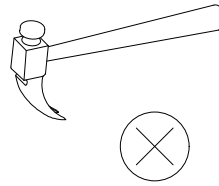
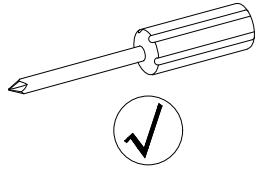
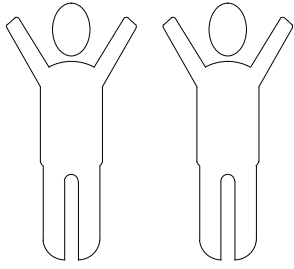

# Parts List (EN)

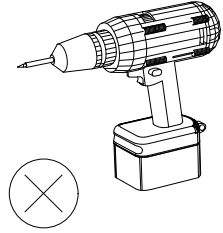
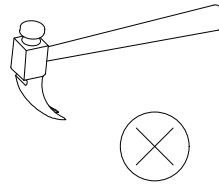
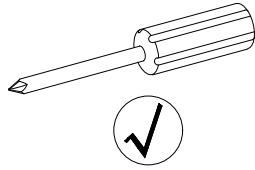
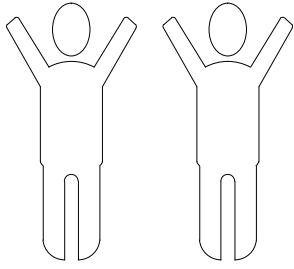

<p><b>17</b></p> <p>1PCS</p>	<p><b>18</b></p> <p>2PCS</p>	<p><b>19</b></p> <p>1PCS</p>	<p><b>20</b></p> <p>1PCS</p>
------------------------------	------------------------------	------------------------------	------------------------------





<p><b>21</b></p> <p>2PCS</p>	<p><b>22</b></p> <p>4PCS</p>	<p><b>23</b></p> <p>3PCS</p>	<p><b>24</b></p> <p>3PCS</p>
------------------------------	------------------------------	------------------------------	------------------------------

<p><b>25</b></p> <p>2PCS</p>	<p><b>26</b></p> <p>1PCS</p>	<p><b>27</b></p> <p>3PCS</p>	<p><b>28</b></p> <p>3PCS</p>
------------------------------	------------------------------	------------------------------	------------------------------

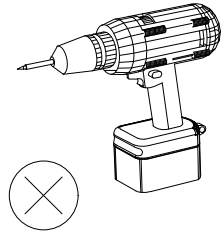
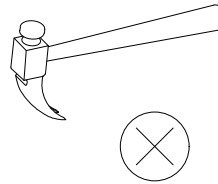
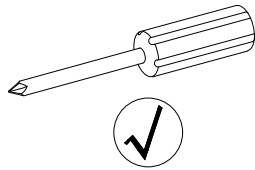
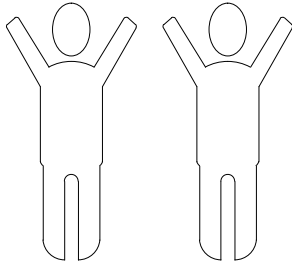
<p><b>29</b></p> <p>2PCS</p>	<p><b>30</b></p> <p>1PCS</p>	<p><b>31</b></p> <p>2PCS</p>	<p><b>32</b></p> <p>1PCS</p>
------------------------------	------------------------------	------------------------------	------------------------------

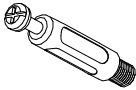
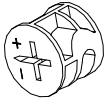
# Parts List (EN)

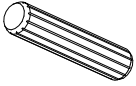
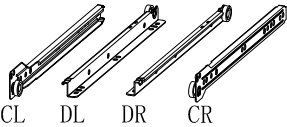
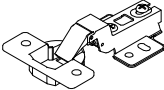
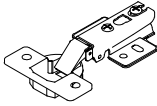
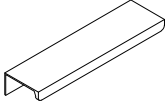

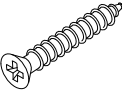
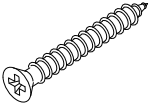
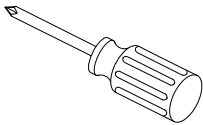
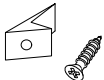
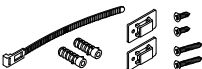
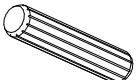
<p><b>No. A</b> Quantity:88+3 Pcs Cam Lock Dowel 8*28mm</p> 	<p><b>No. B</b> Quantity:88+3 Pcs Cam φ15</p> 	<p><b>No. C</b> Quantity:48+2 Pcs Sticker Ø20</p> 	<p><b>No. D</b> Quantity:34+2 Pcs Dowel 8*30mm</p> 
<p><b>No. E</b> Quantity:3 Sets Ordinary bottom-dragging rail 12"</p> 	<p><b>No. F</b> Quantity:8 Pcs Hinge</p> 	<p><b>No. G</b> Quantity:4 Pcs Hinge</p> 	<p><b>No. H</b> Quantity:9 Pcs Handle</p> 
<p><b>No. I</b> Quantity:8+1 Pcs Foot Pad Ø12*5</p> 	<p><b>No. J</b> Quantity:106+4 Pcs Screw M3.5*14mm</p> 	<p><b>No. K</b> Quantity:12+1 Pcs Screw M3.5*25mm</p> 	<p><b>No. L</b> Quantity:12+1 Pcs Screw M4*30mm</p> 
<p><b>No. M</b> Quantity:1 Pcs Screwdriver</p> 	<p><b>No. N</b> Quantity:24+2 Sets Plastic Wedge</p> 	<p><b>No. O</b> Quantity:1 Sets Anti-falling Parts</p> 	<p><b>No. P</b> Quantity:4 Pcs Dowel 8*20mm</p> 

# Instructions For Fastening CAM-BOLT and CAM-LOCK

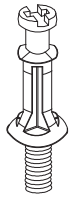

CAM-BOLT



CAM-LOCK

Tools Required

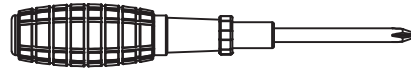

## INSERTING AND TIGHTENING CAM-BOLT

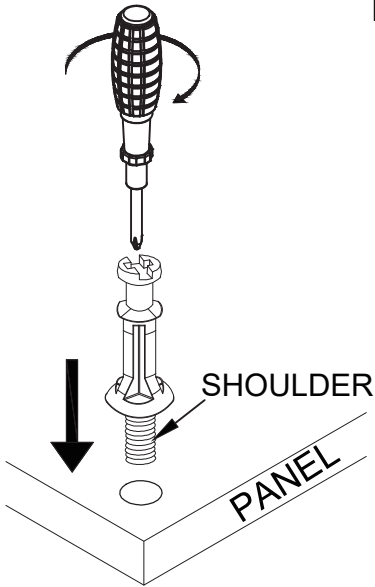

Place Cam-bolt on pre-drilled hole and screw in vertically

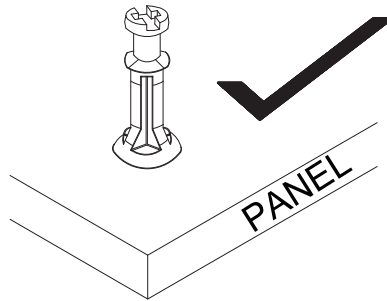

Shoulder is flushed (on the same level) with the panel.

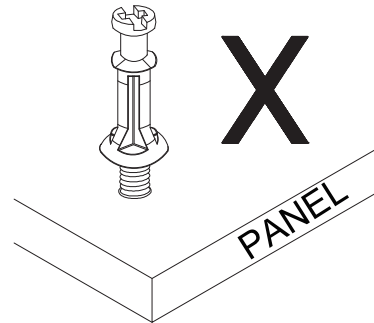

Shoulder is above the panel.

Place Cam-bolt on the designated pre-drilled holes on the panel. Use a Phillips Screwdriver to screw-in Cam-bolt vertically until shoulder is flushed (on the same level) with panel.

## INSERTING CAM-LOCK

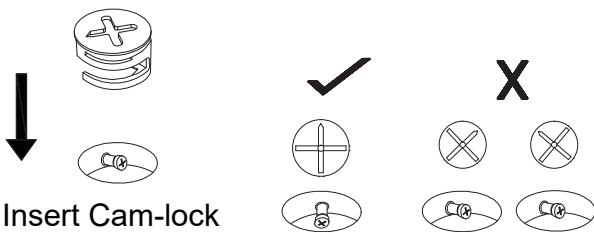

Insert Cam-lock with arrow align to Cam-bolt head

CORRECT

WRONG

## TIGHTENING CAM-LOCK

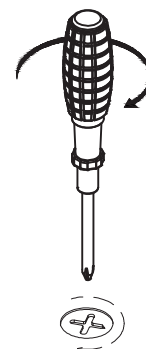

Align the arrow on the Cam-lock to the Cam-bolt head and insert the Cam-lock. Ensure Cam-lock is fully inserted.

Use a Flat-head Screwdriver to turn Camlock clockwise so it locks onto the head of the Cam-bolt. Turn until it is snug (about 3/4ths of a turn) -- over-tightening could damage Cam-lock or/and Cam-bolt.

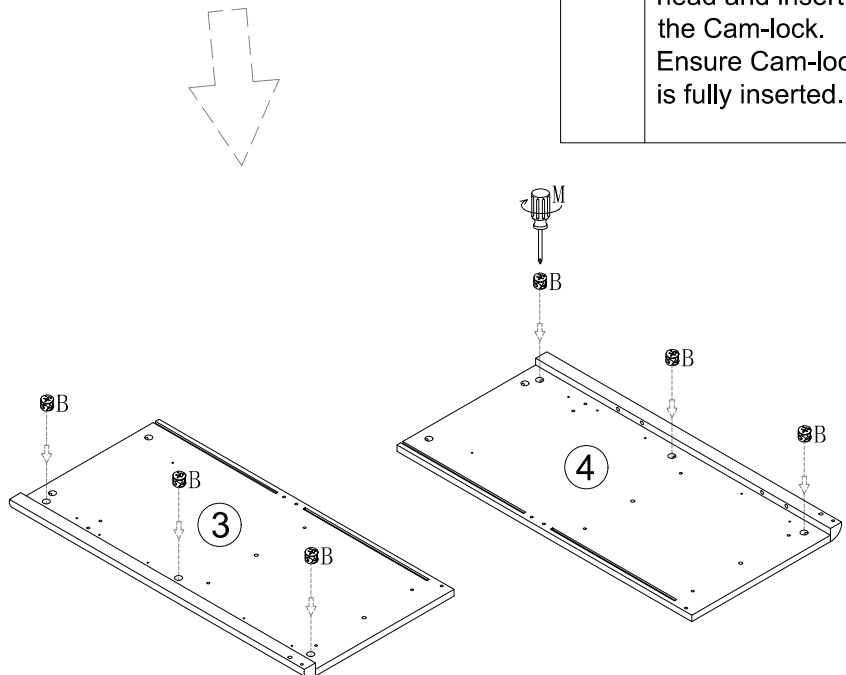
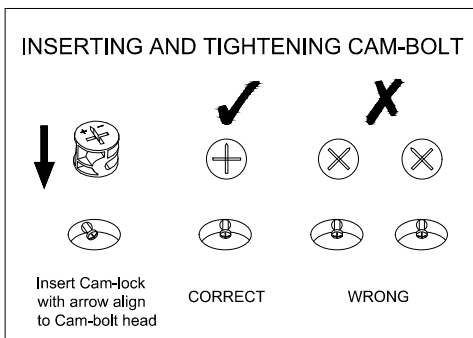
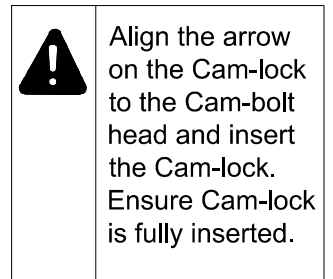
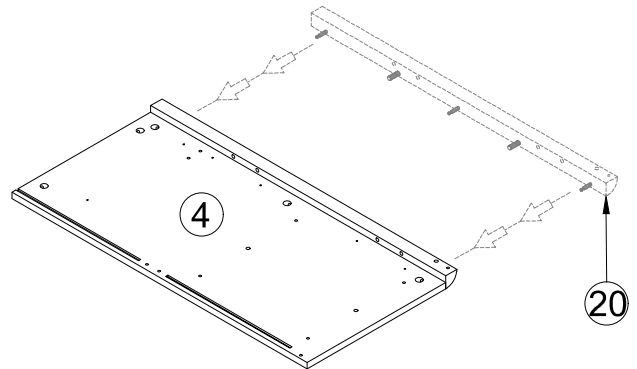
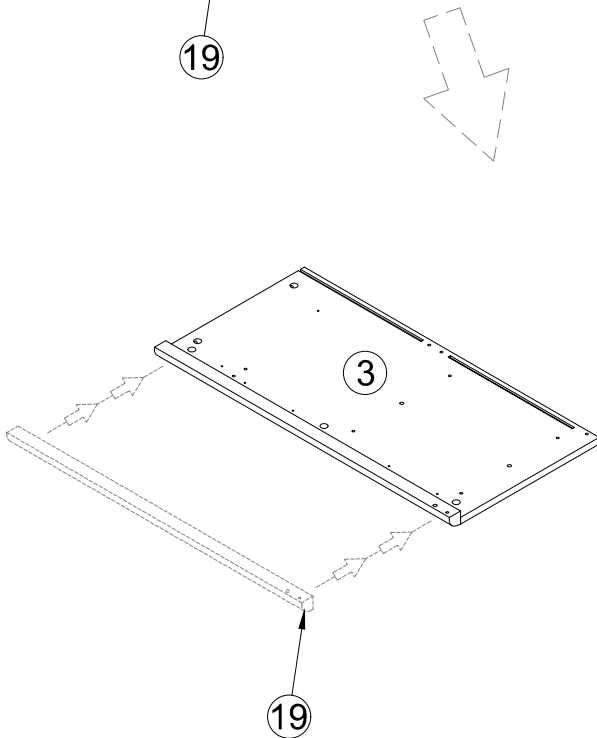
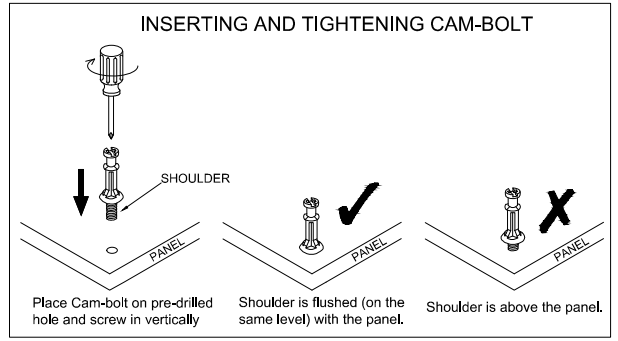
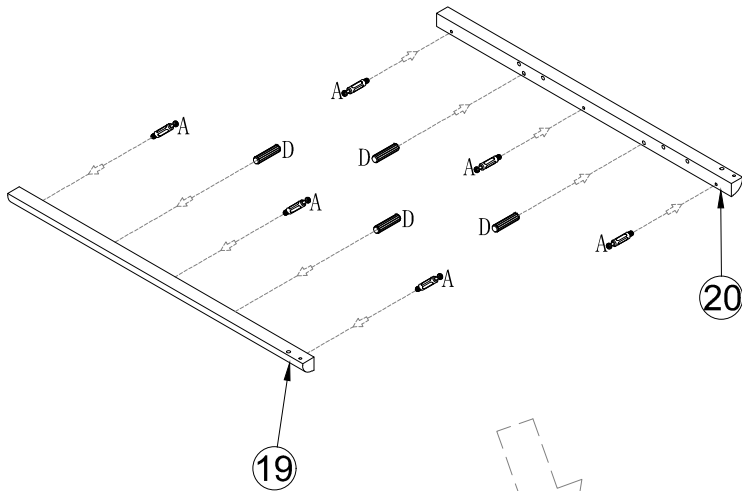

# STEP 1



	A×6PCS
	B×6PCS
	D×4PCS

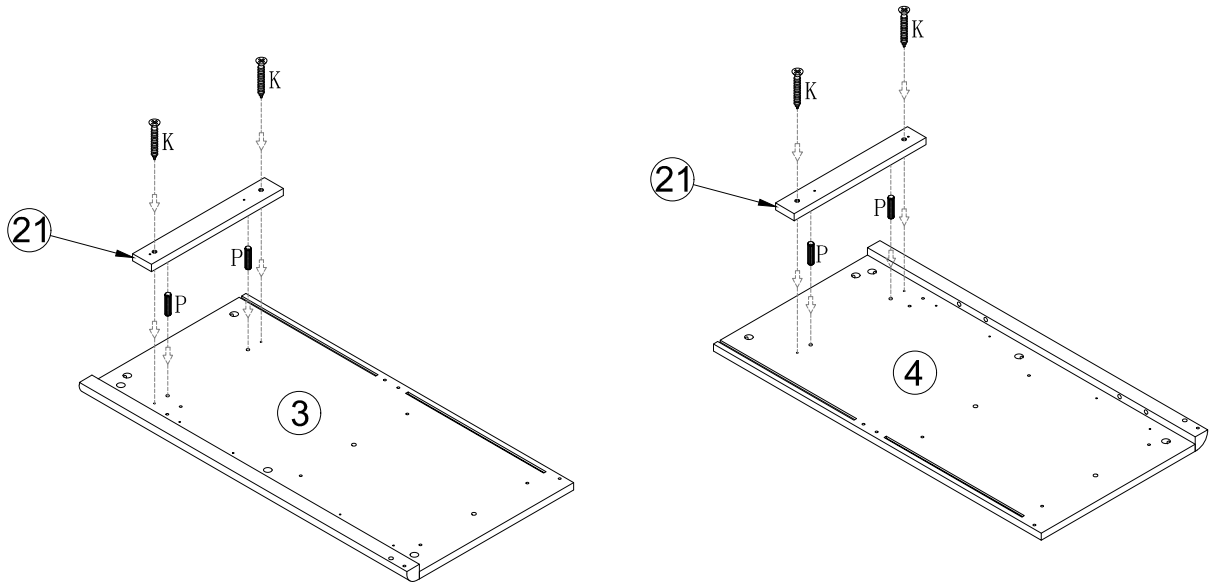

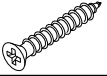
# STEP 2

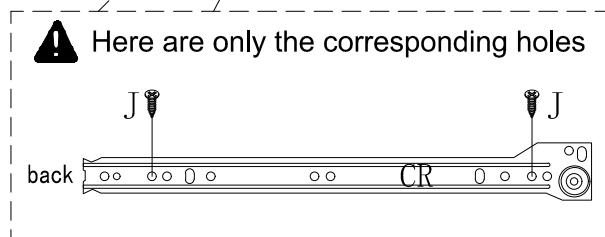
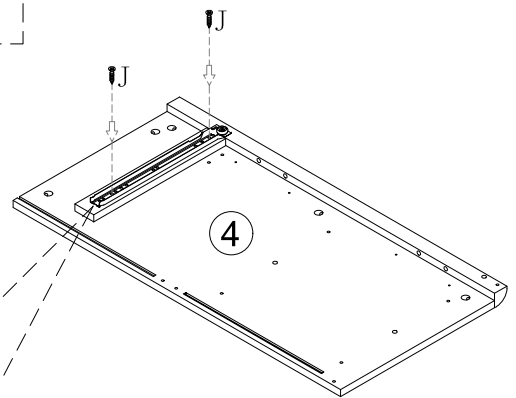
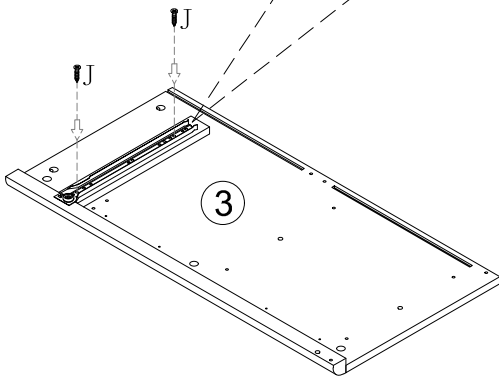
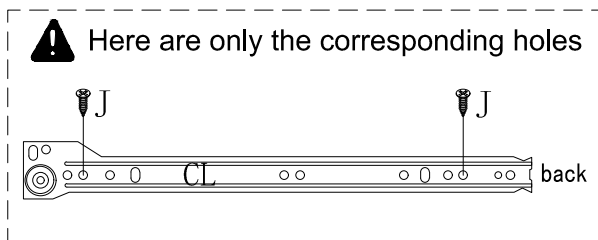

	K×4PCS
	P×4PCS

# STEP 3



 	E×2PCS
	J×4PCS

# STEP 4

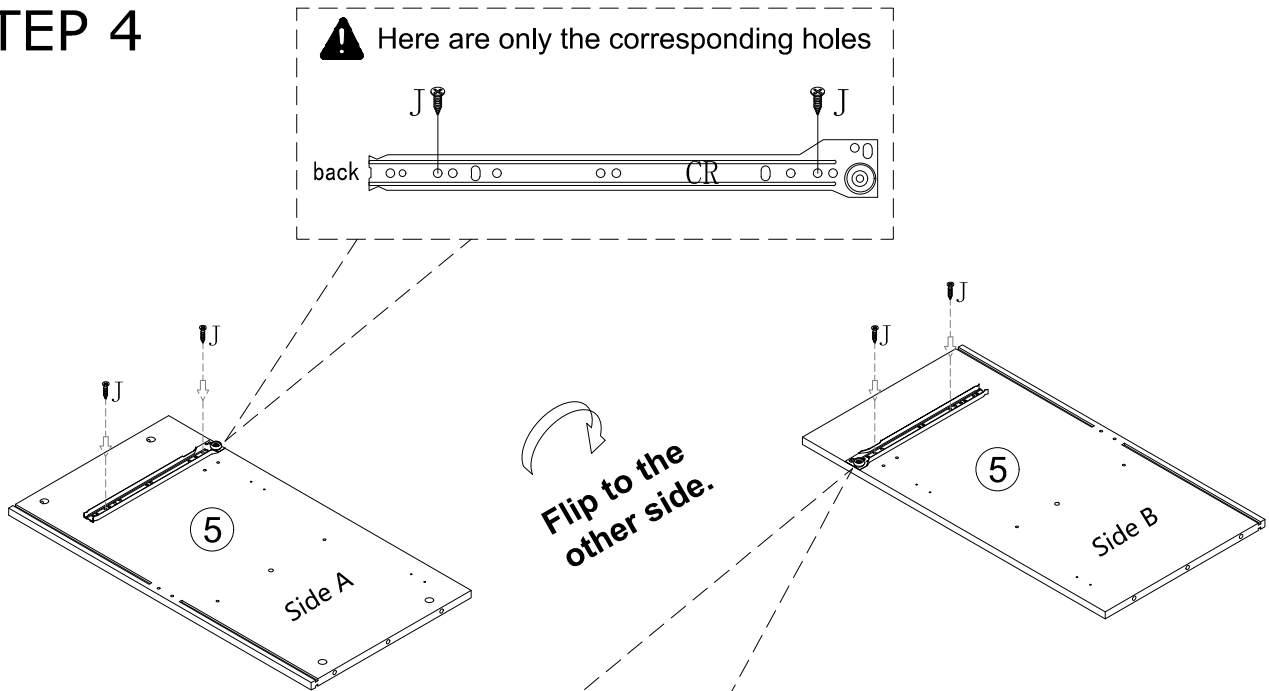

CL	CR	E×2PCS
		J×4PCS

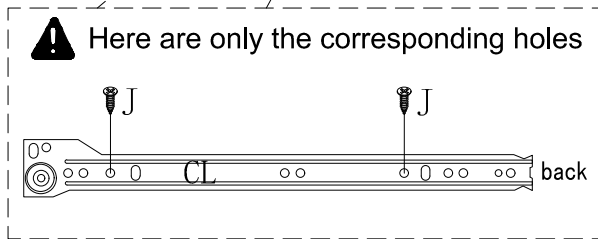

# STEP 5

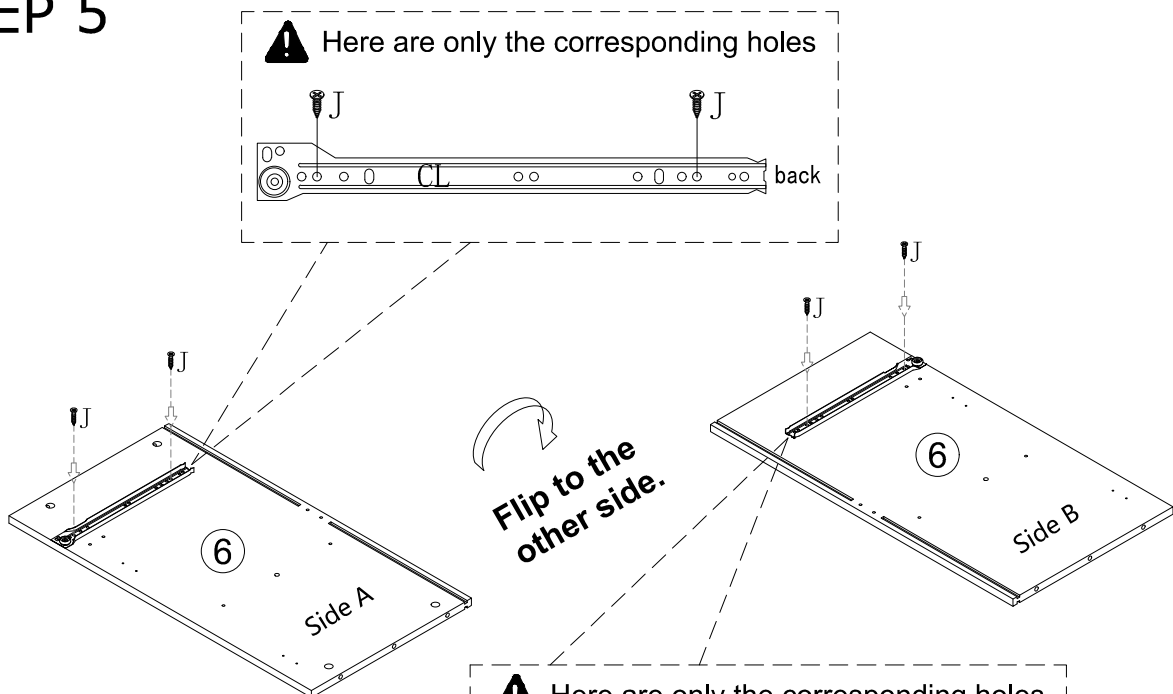

CL	CR	E×2PCS
		J×4PCS

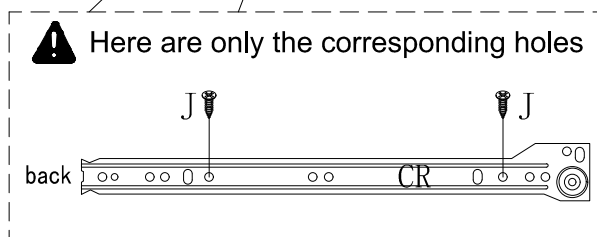

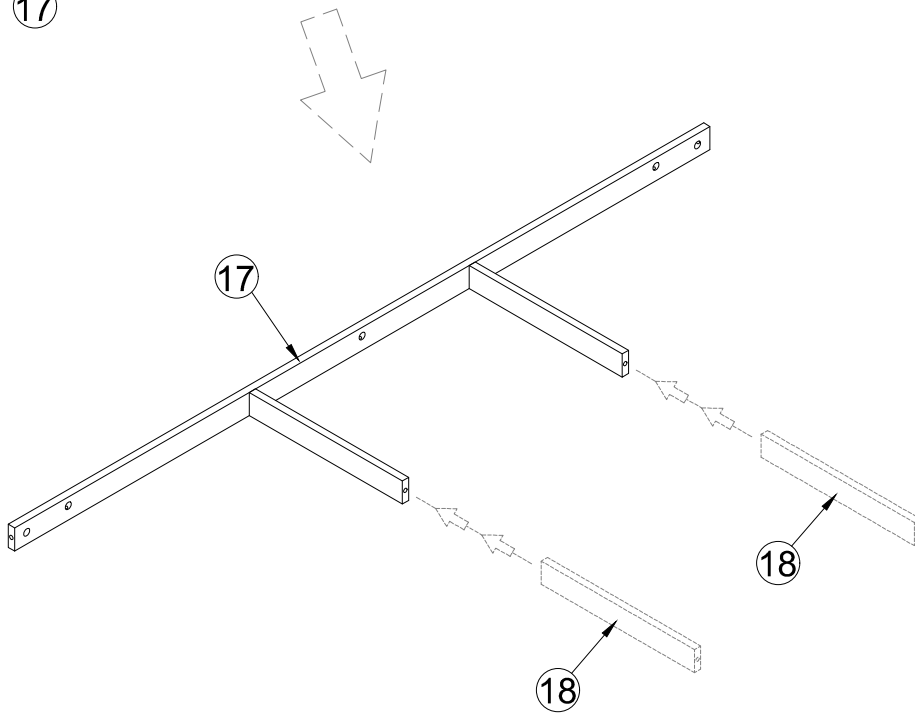
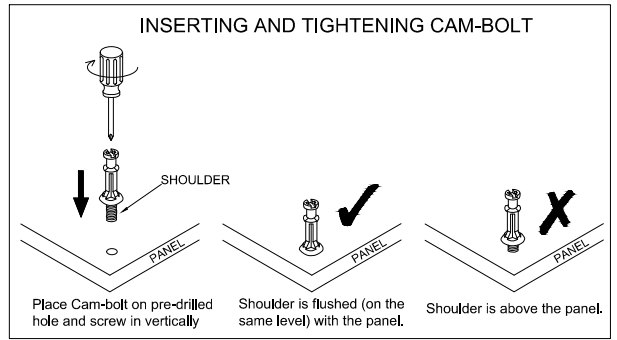
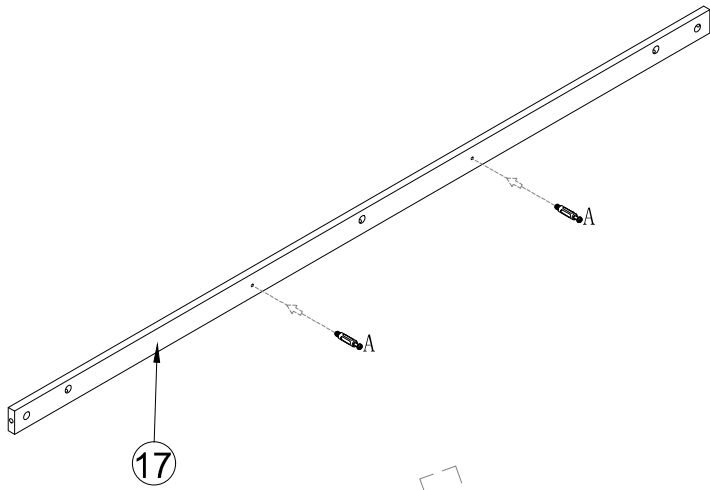

# STEP 6

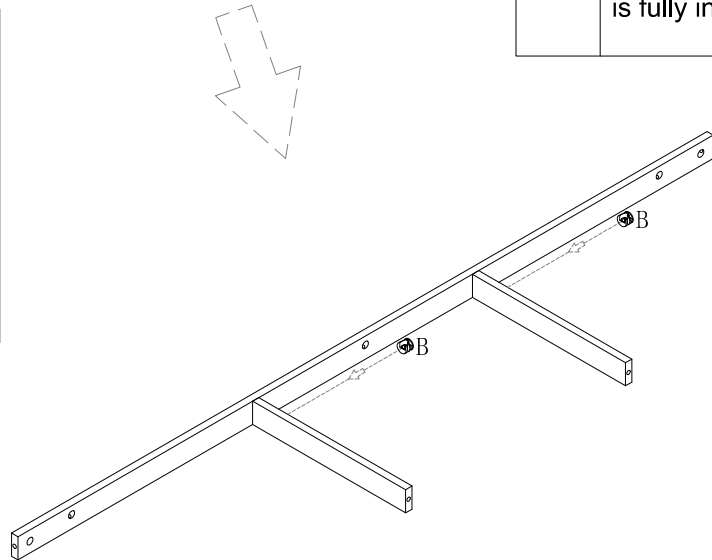
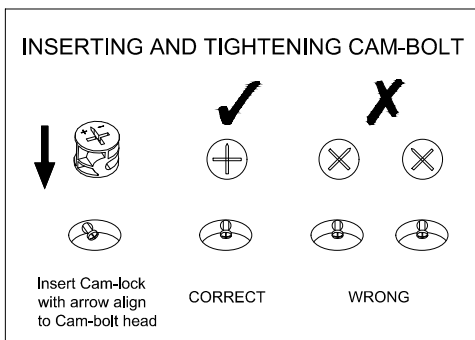

**!** Align the arrow on the Cam-lock to the Cam-bolt head and insert the Cam-lock. Ensure Cam-lock is fully inserted.

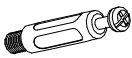

	A×2PCS
	B×2PCS

# STEP 7



Note: This block has holes on both sides, please pay attention to the difference.

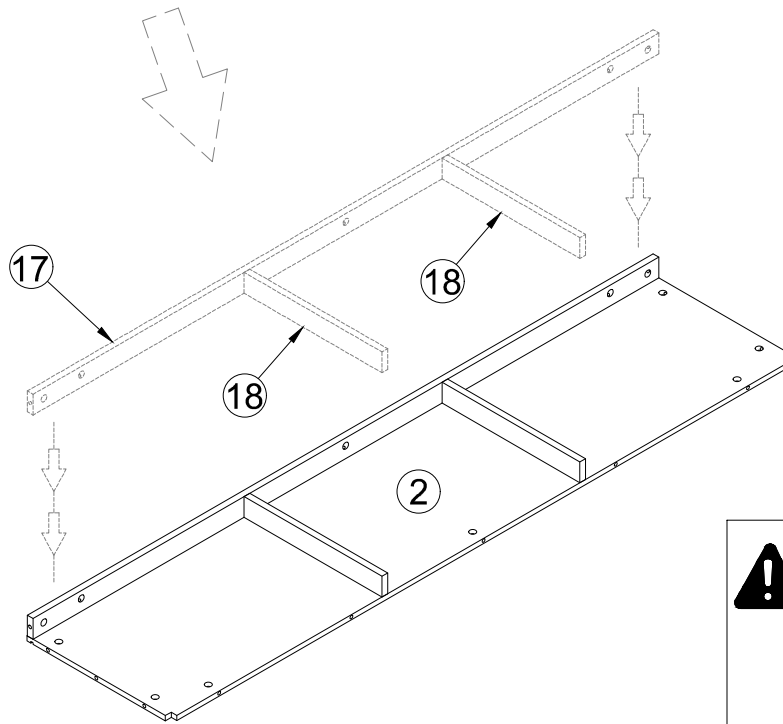
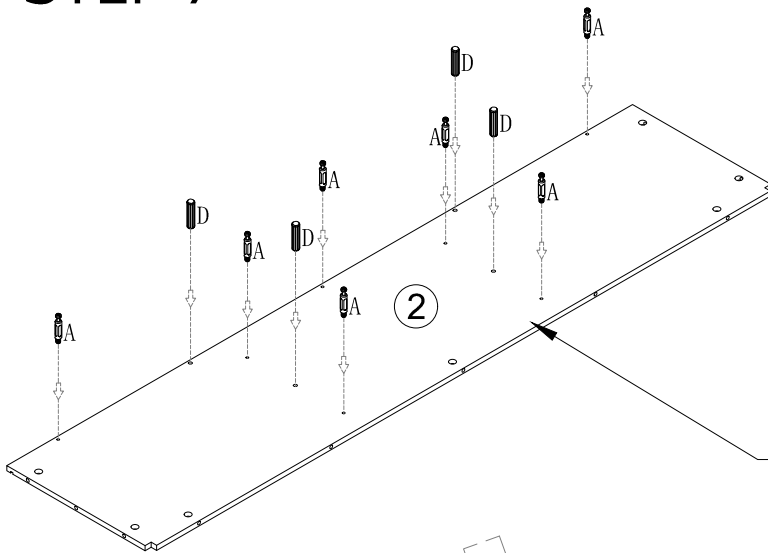

**!** Align the arrow on the Cam-lock to the Cam-bolt head and insert the Cam-lock. Ensure Cam-lock is fully inserted.

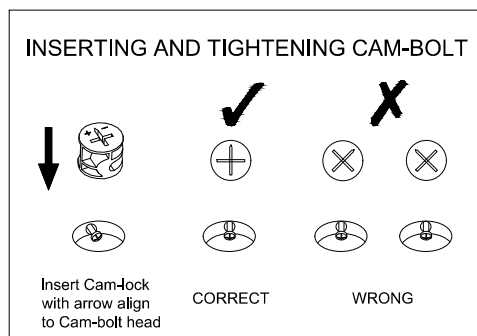

	A×7PCS
	B×7PCS
	D×4PCS

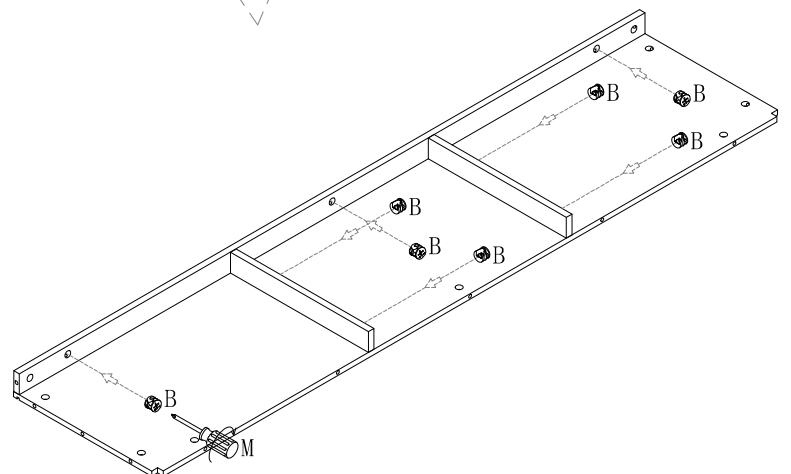

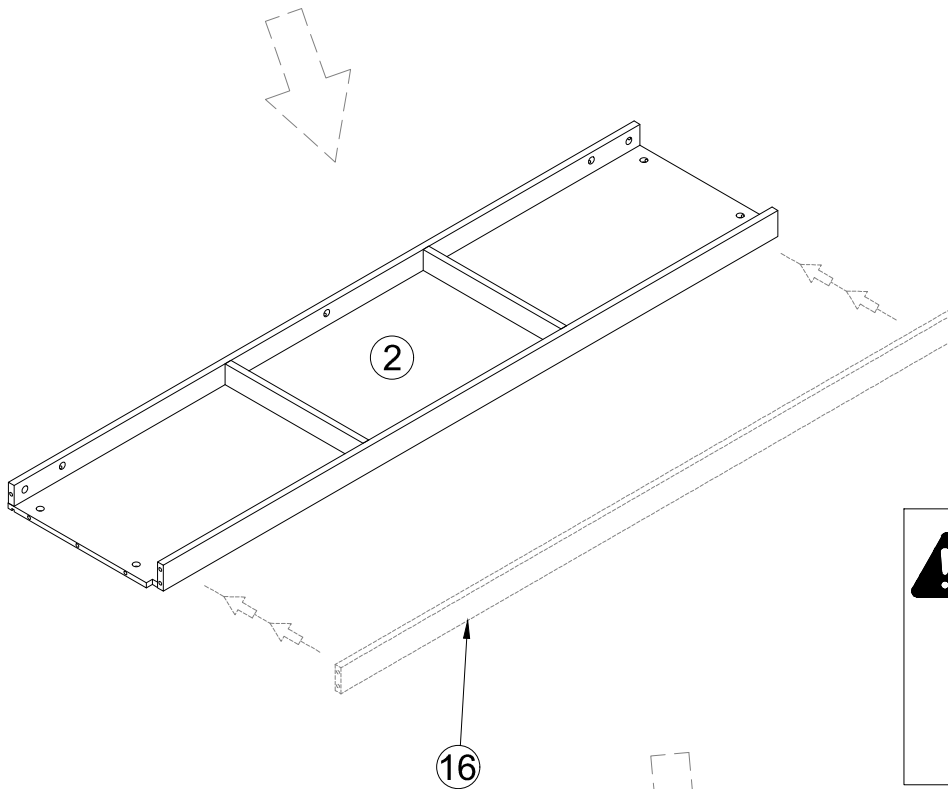
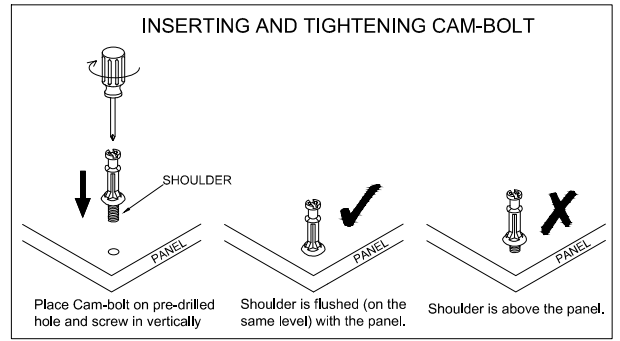
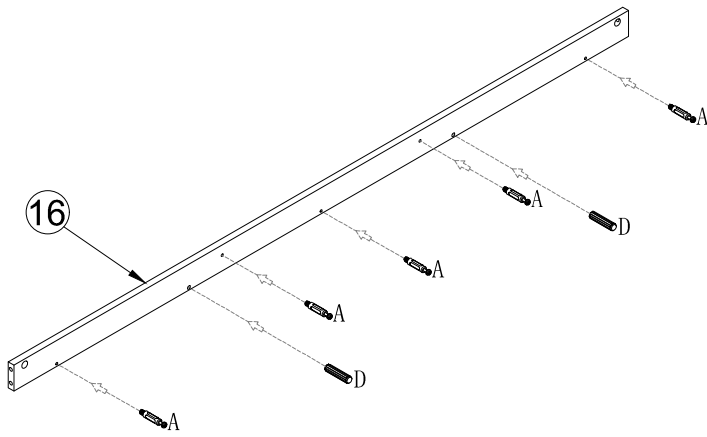

# STEP 8



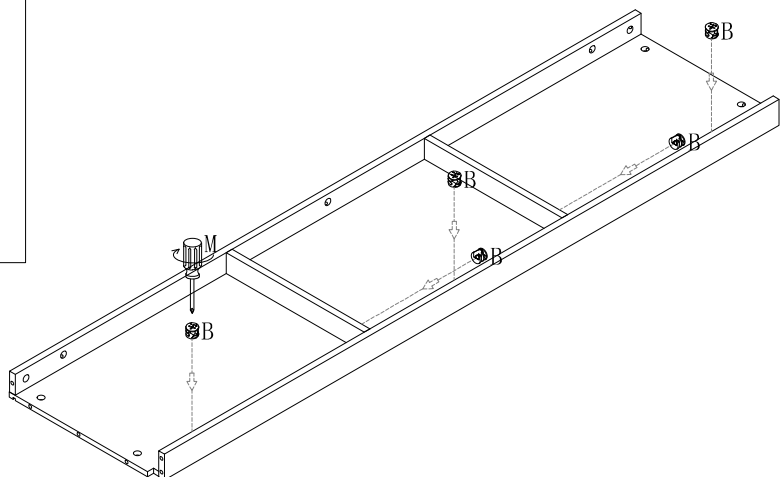
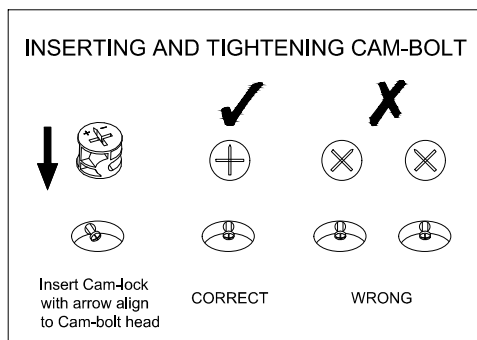

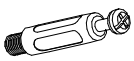

 Align the arrow on the Cam-lock to the Cam-bolt head and insert the Cam-lock. Ensure Cam-lock is fully inserted.

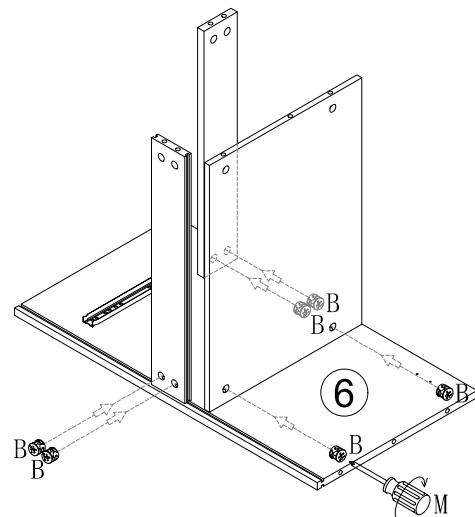
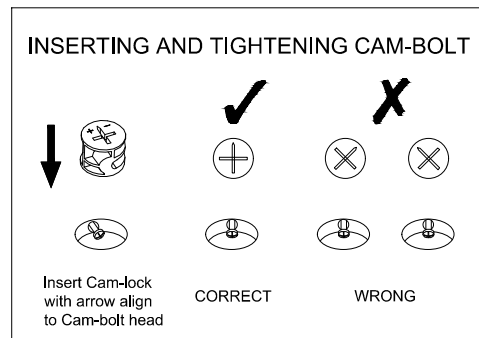
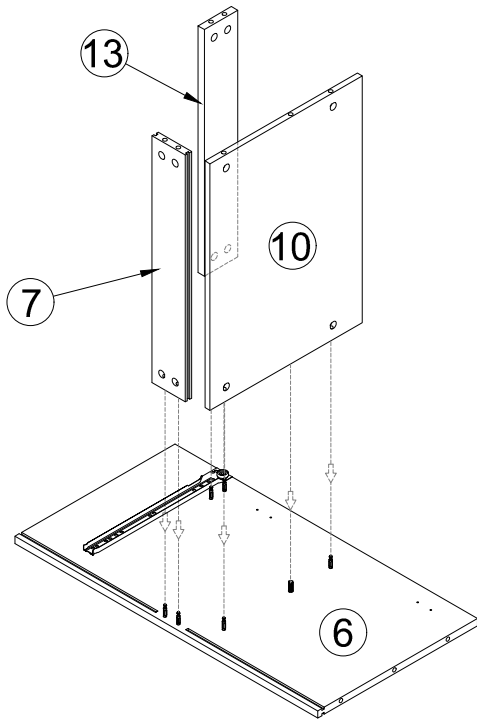
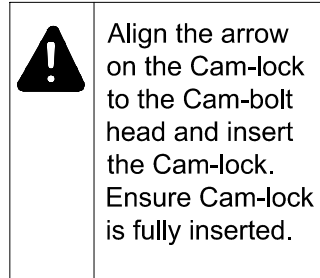
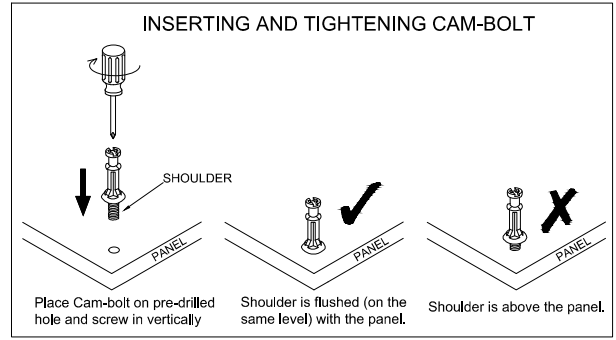
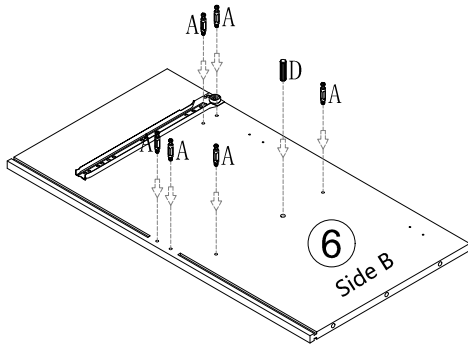

	A×5PCS
	B×5PCS
	D×2PCS



# STEP 9

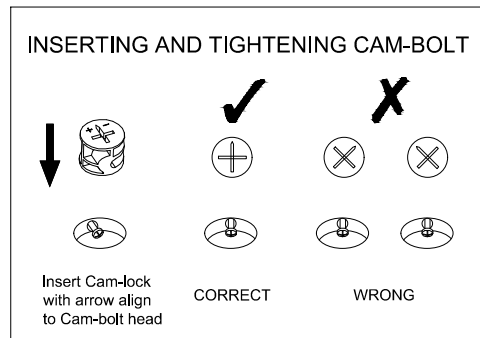
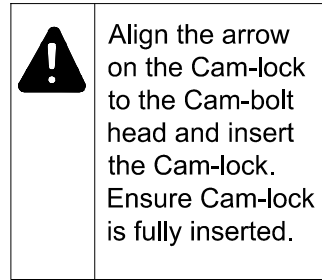
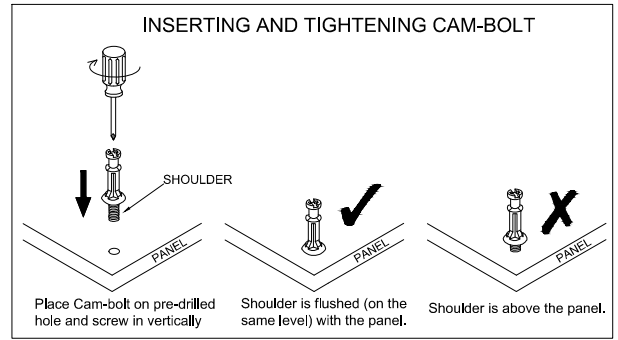
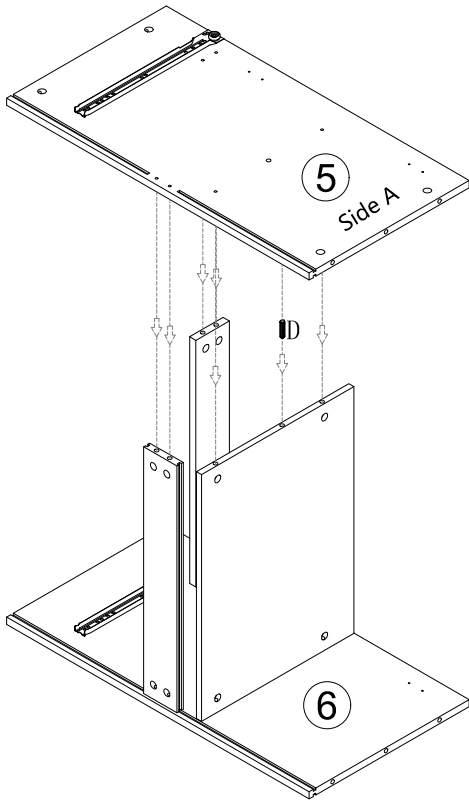
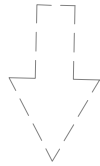
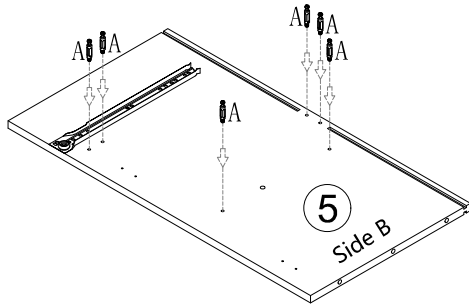

	A×6PCS
	B×6PCS
	D×1PCS

# STEP 10



	A×6PCS
	B×6PCS
	D×1PCS

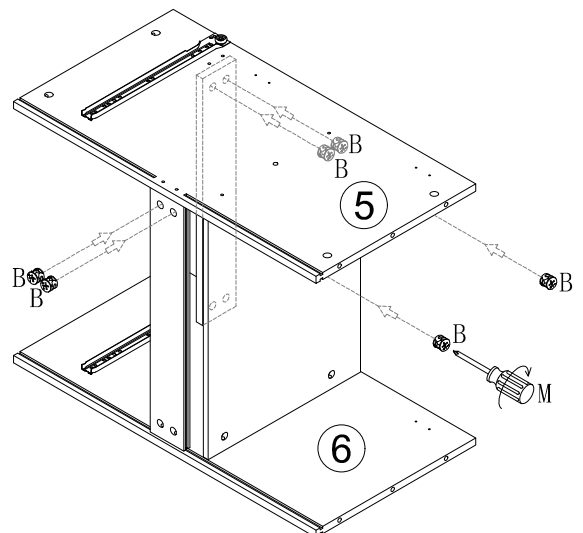

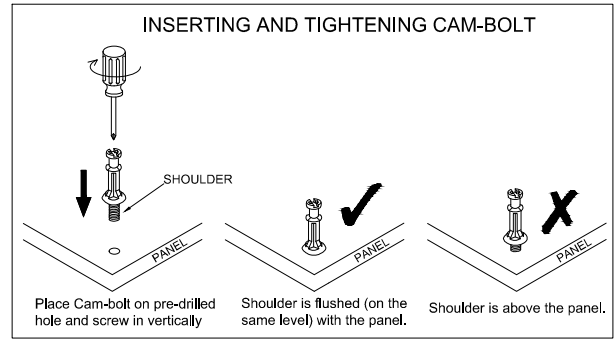
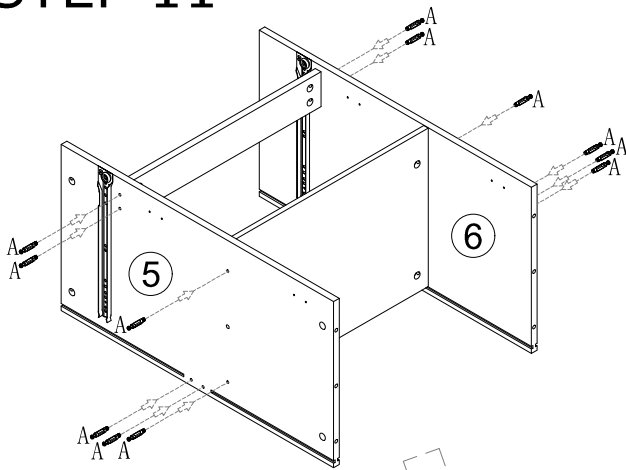

# STEP 11



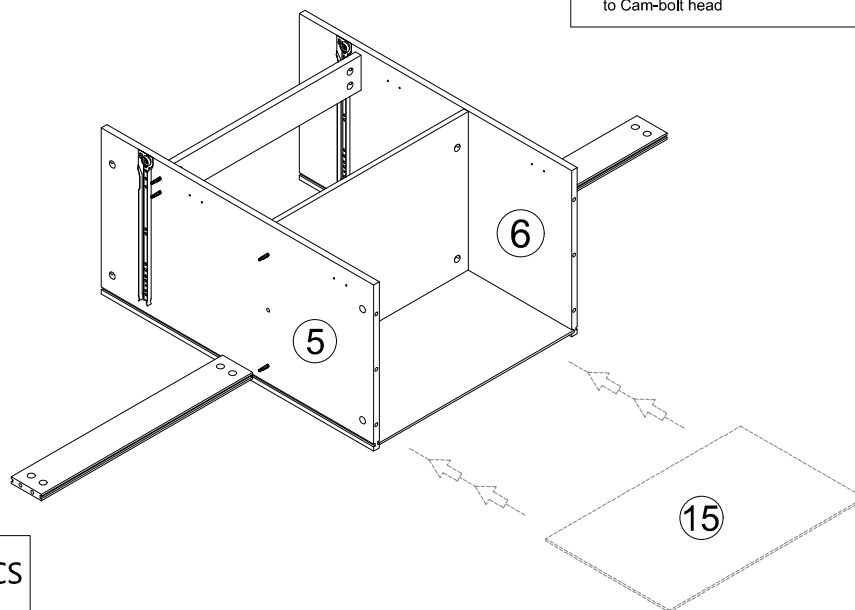
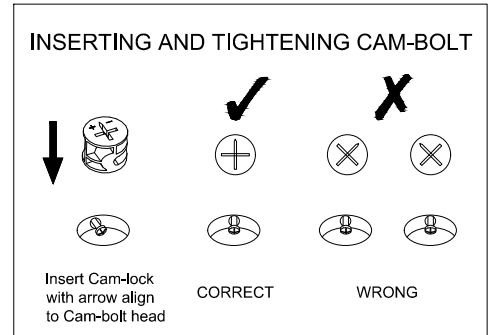
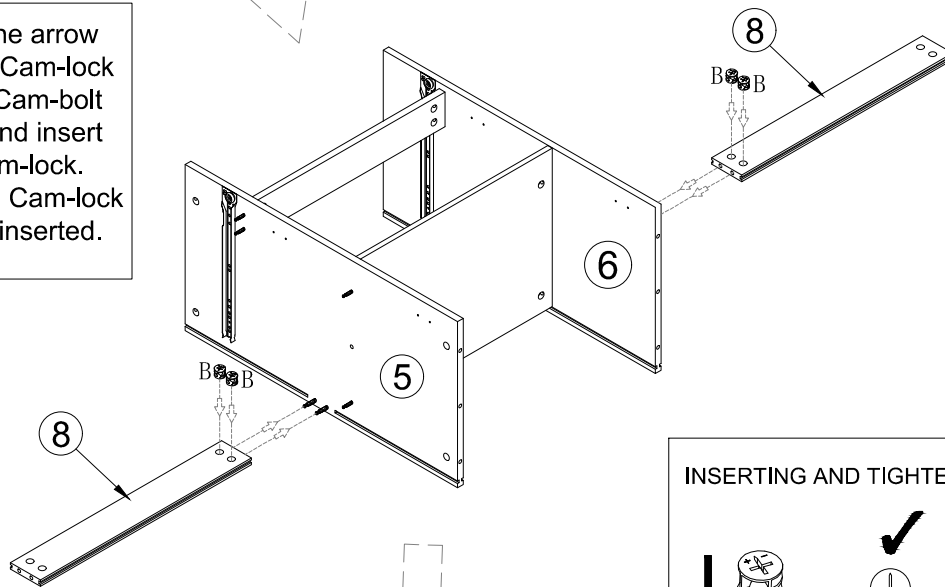

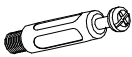

**!** Align the arrow on the Cam-lock to the Cam-bolt head and insert the Cam-lock. Ensure Cam-lock is fully inserted.

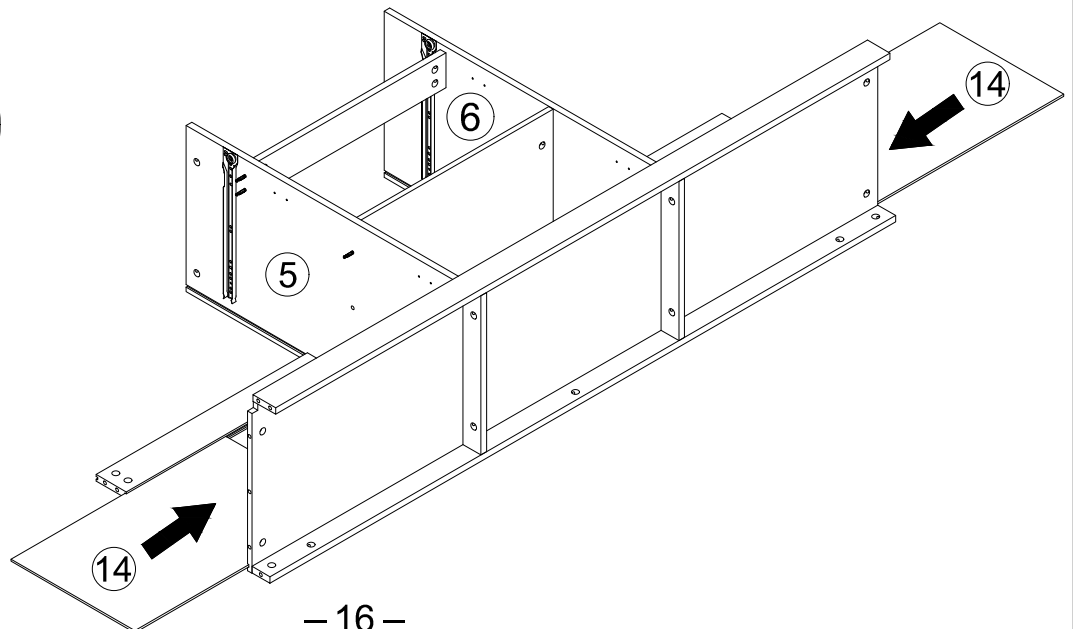
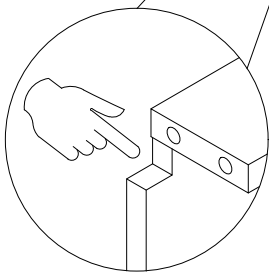
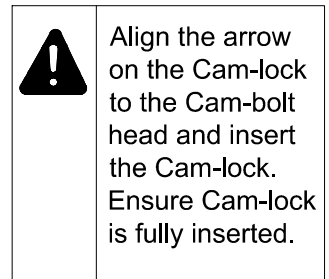
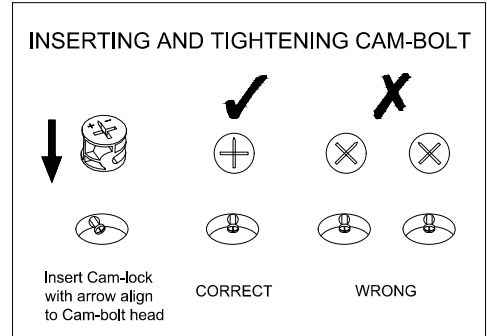
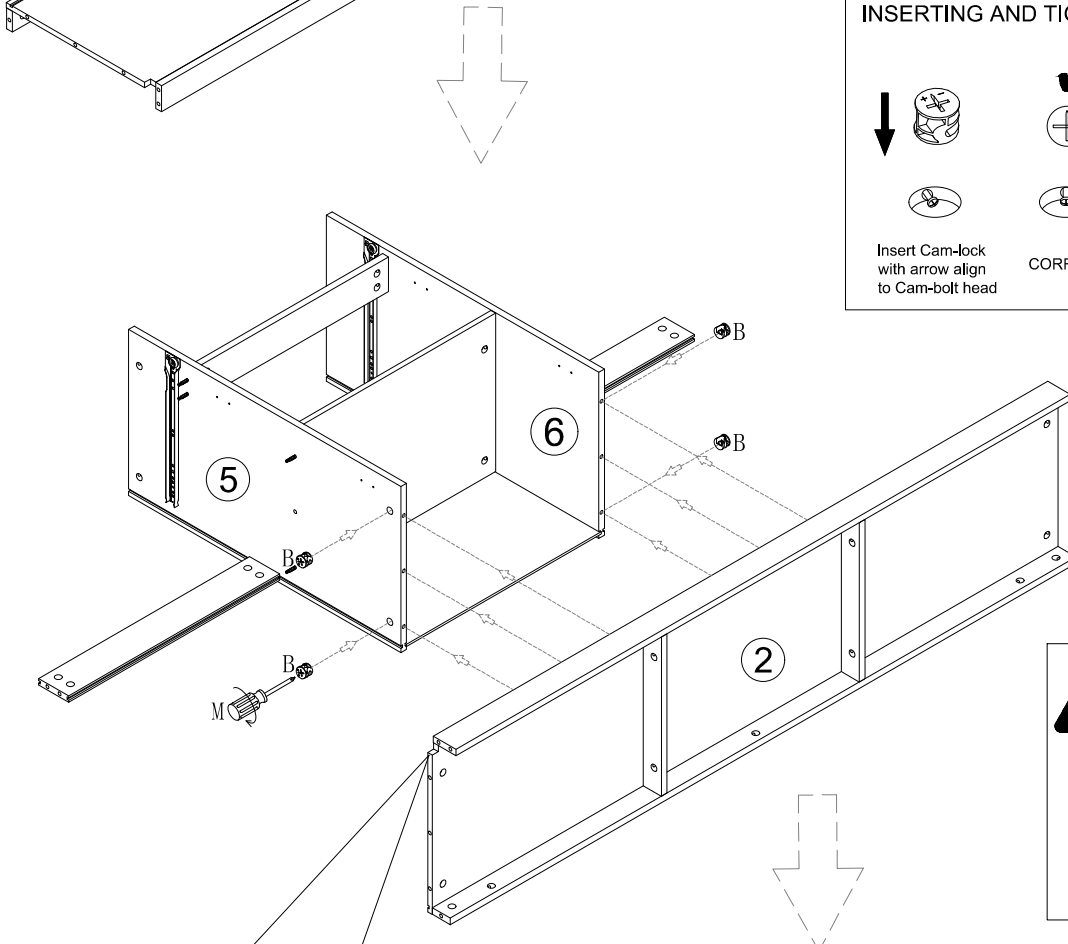
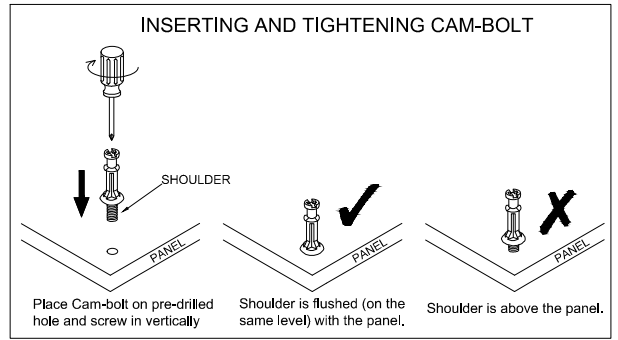
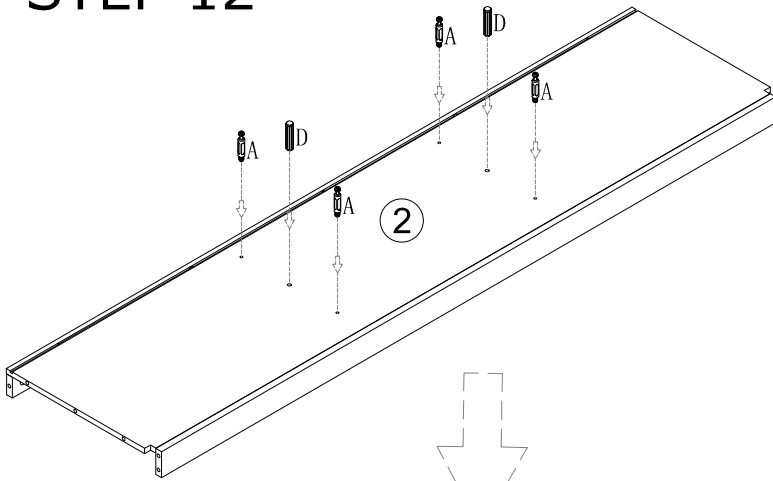

	A×12PCS
	B×4PCS

# STEP 12



	A×4PCS
	B×4PCS
	D×2PCS

# STEP 13

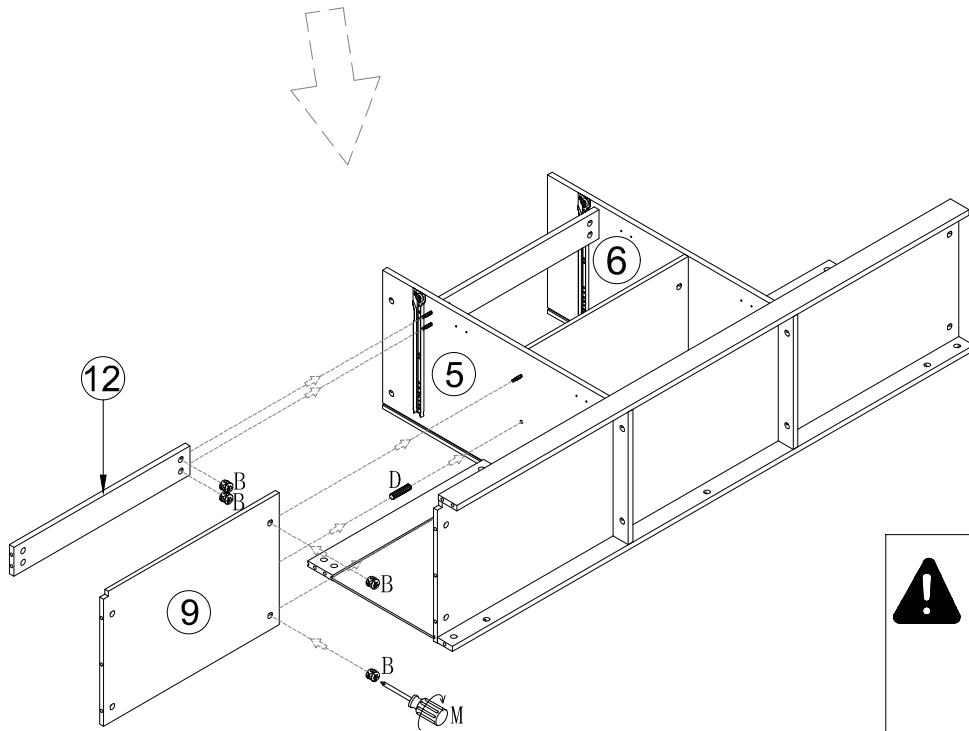
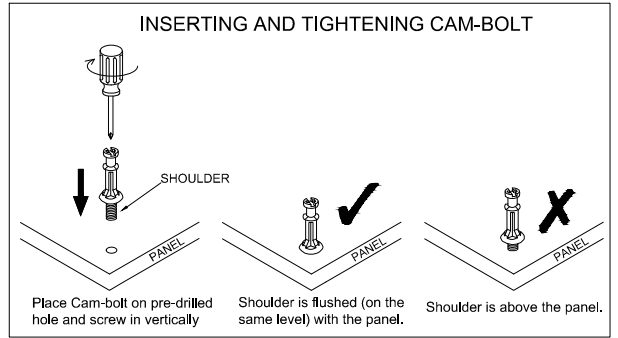
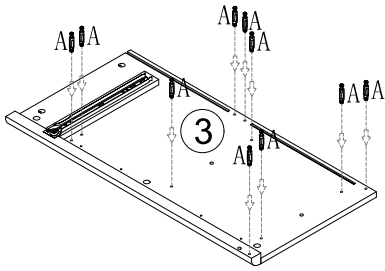

**!** Align the arrow on the Cam-lock to the Cam-bolt head and insert the Cam-lock. Ensure Cam-lock is fully inserted.

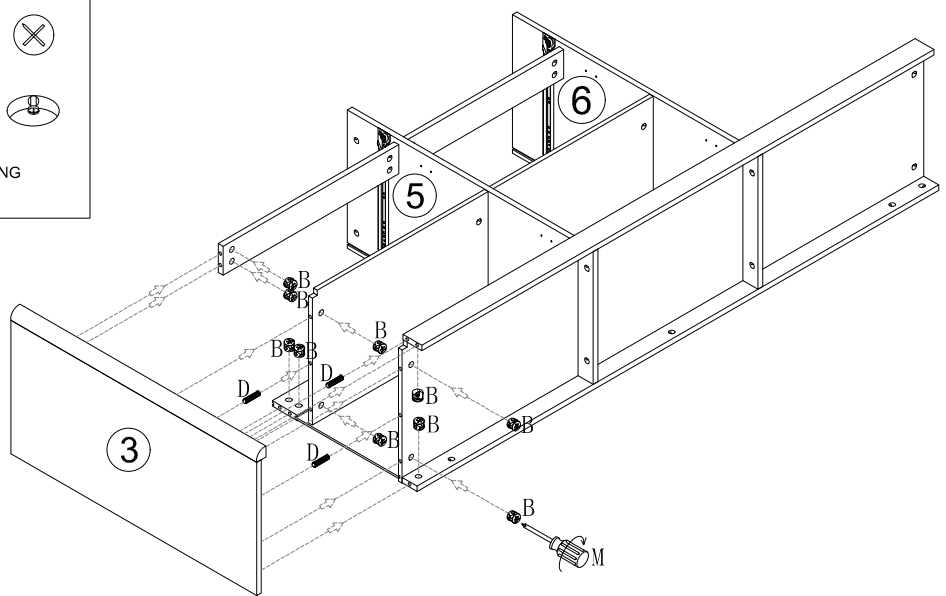
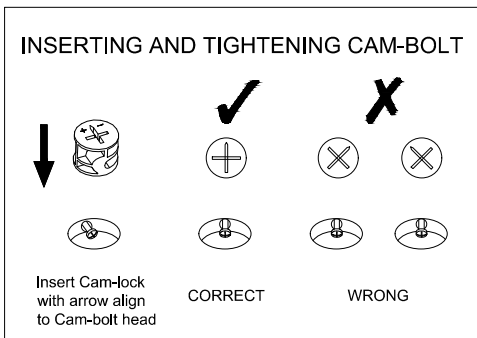

	A×10PCS
	B×14PCS
	D×4PCS

# STEP 14

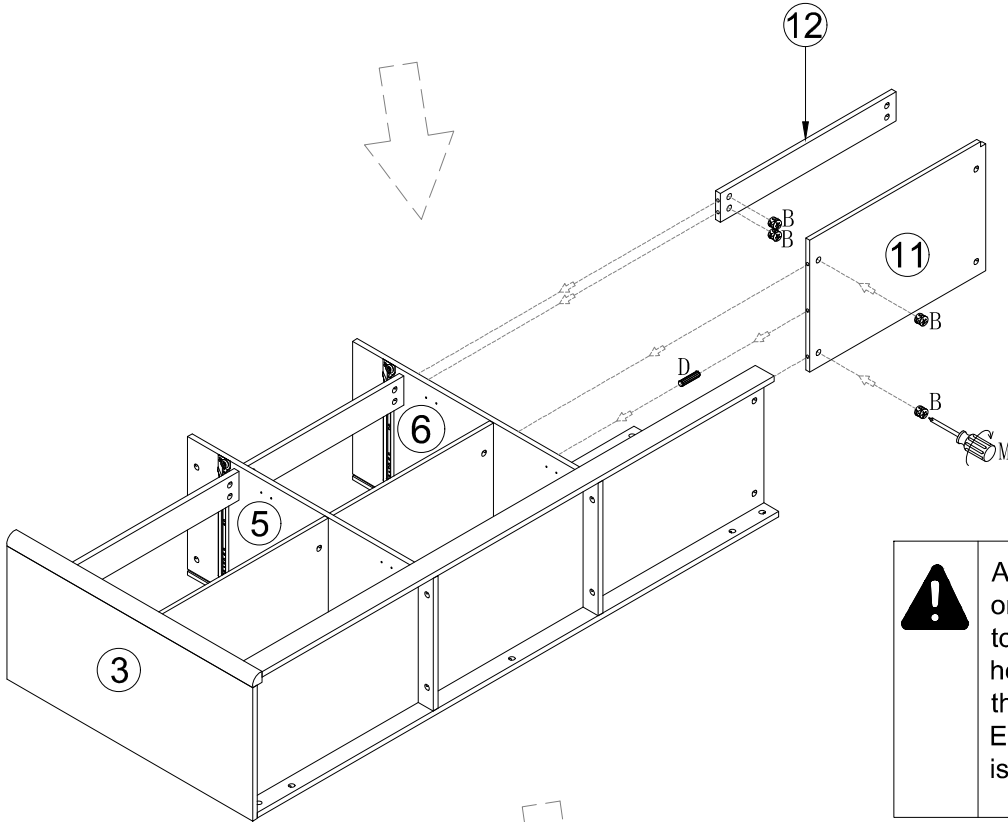
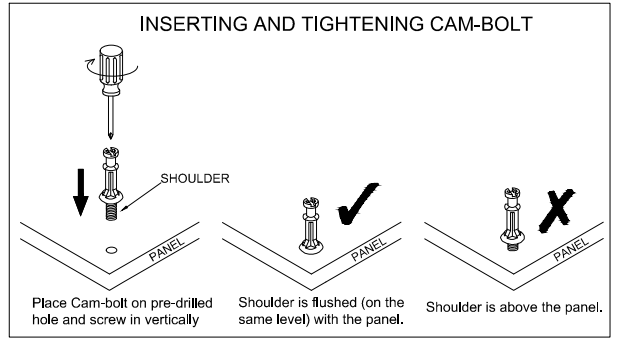
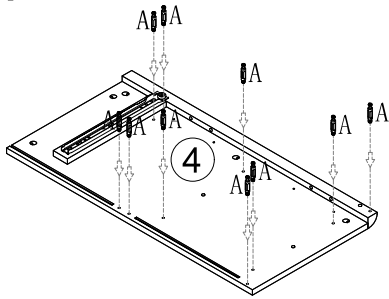

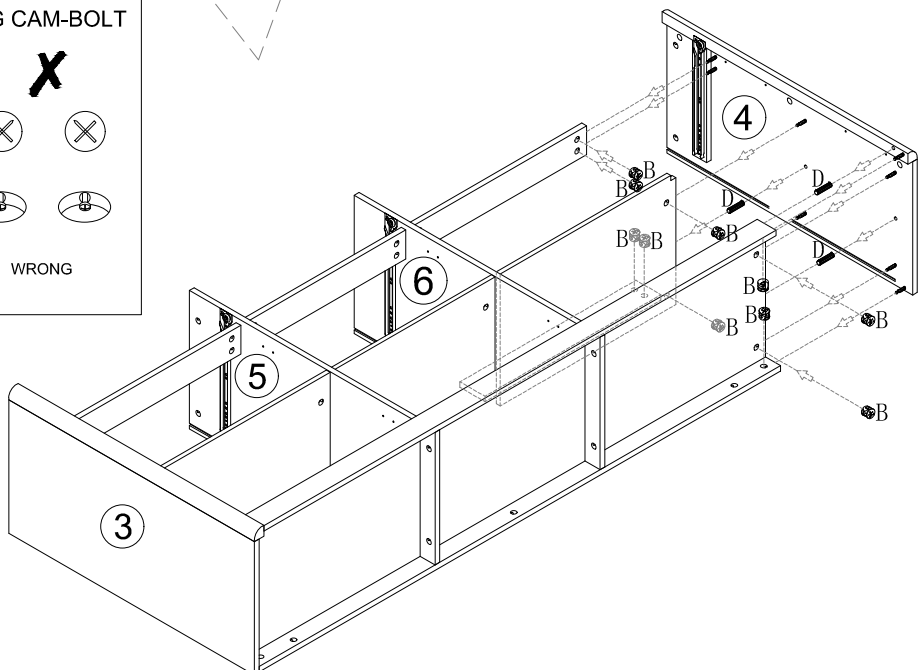
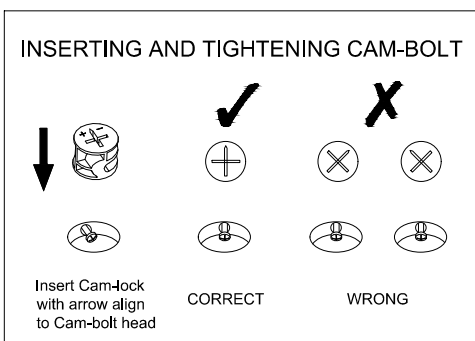

**!** Align the arrow on the Cam-lock to the Cam-bolt head and insert the Cam-lock. Ensure Cam-lock is fully inserted.

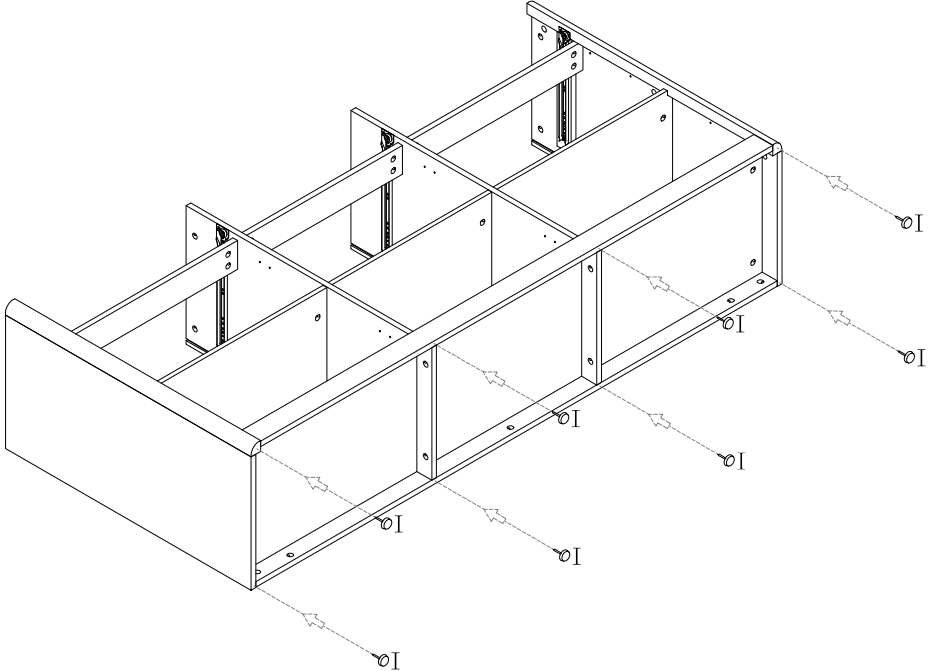

	A×10PCS
	B×14PCS
	D×4PCS

# STEP 15



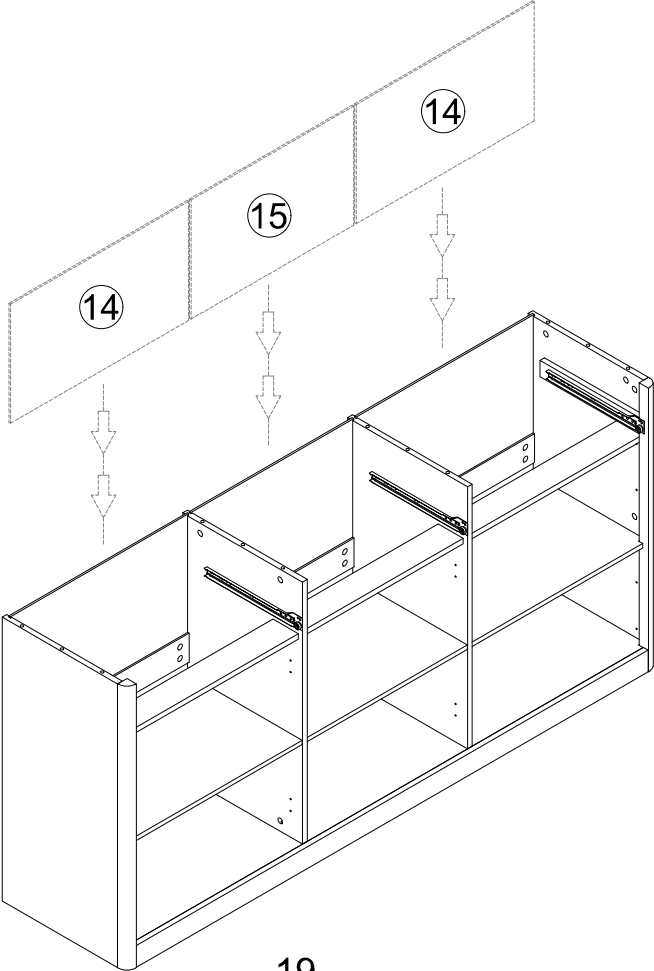

	1×8PCS
---	--------

# STEP 16



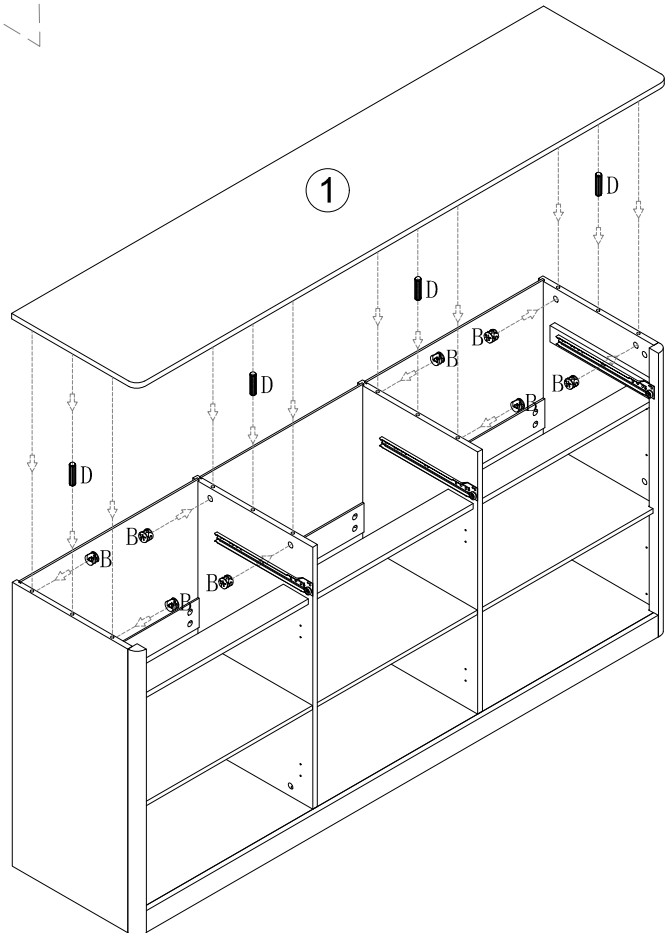
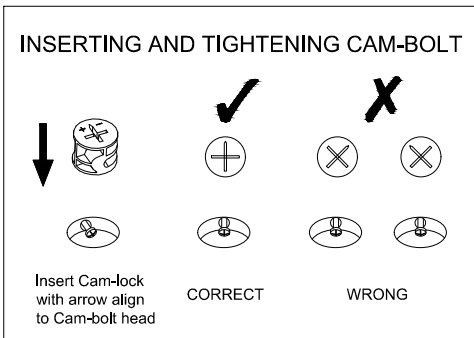
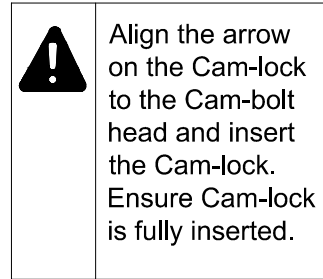
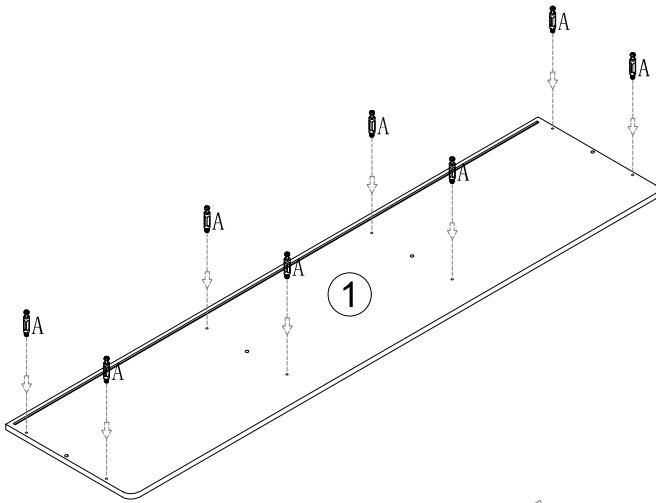
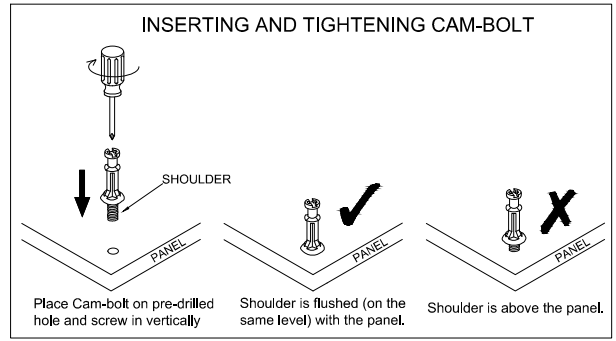

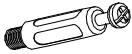
# STEP 17



	A×8PCS
	B×8PCS
	D×4PCS

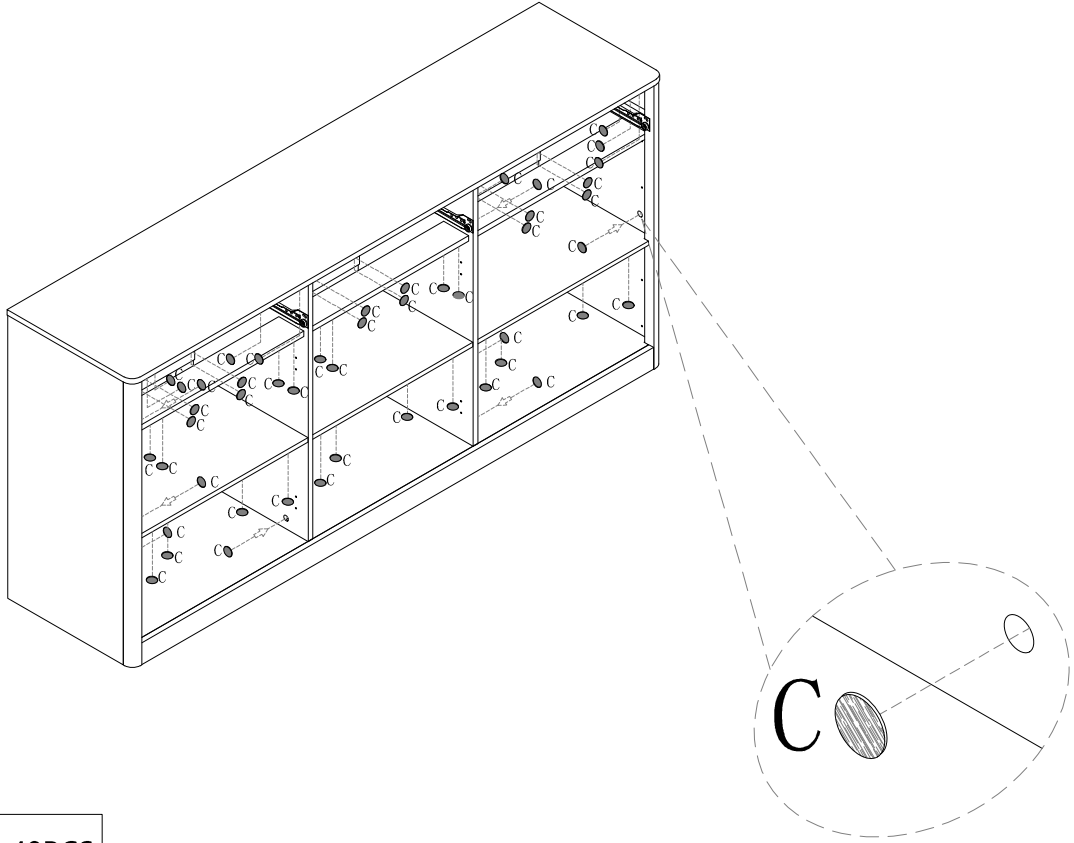

# STEP 18

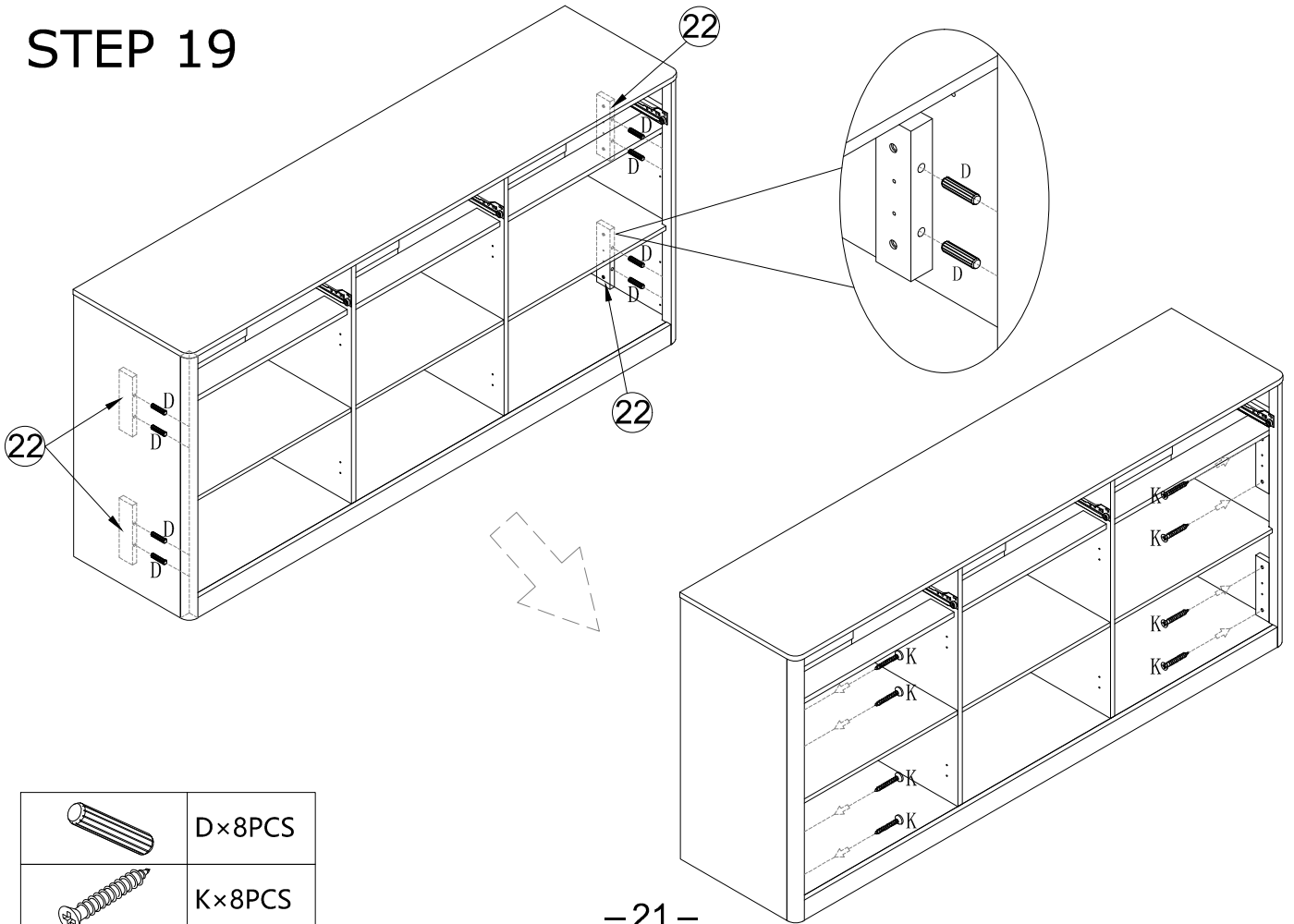

	C×48PCS
---	---------

# STEP 19



	D×8PCS
	K×8PCS



If you encounter the following situation, please follow the steps to correct it.

1. The function of the front screw is to adjust the size of the gap between the door and the side panel.
2. The function of the rear screw is to adjust the distance between the front and rear of the door.

20-A. When the door panel is higher than the side panel.

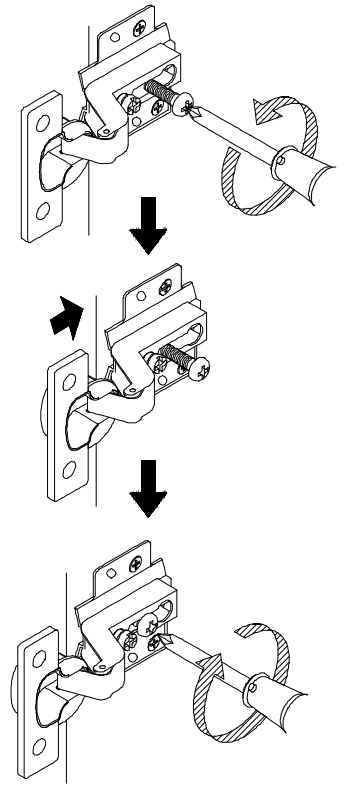
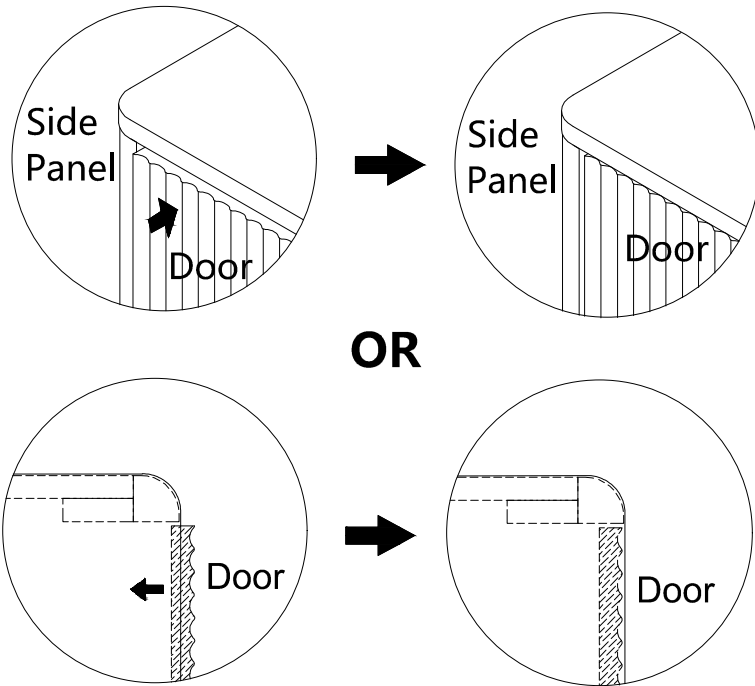

If the gap is too big between side panel and door or the door is over the edge of side panel, loose the back screw as shown, then move in the door with hinge and tighten the back screw as shown when the gap is just well.

20-B. When the door panel is lower than the side panel, an indentation occurs.

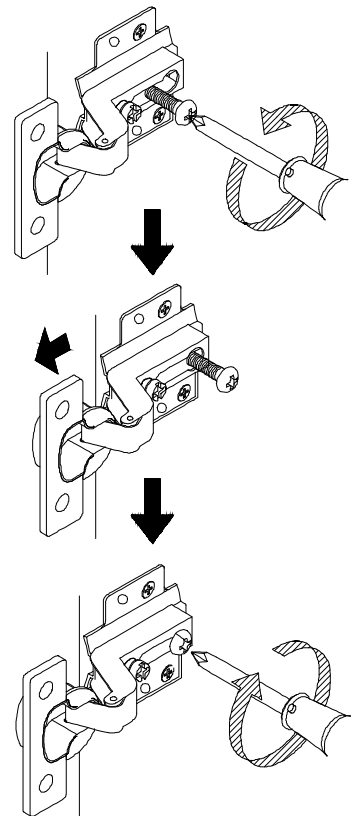
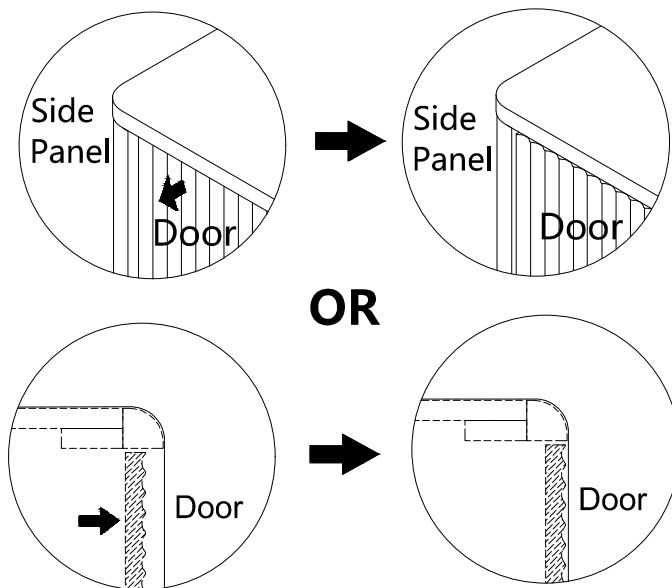

If the gap is too small between side panel and door or the door sank in side panel, loose the back screw as shown, then move out the door with hinge and tighten the back screw as shown when the gap is just well.

20-C

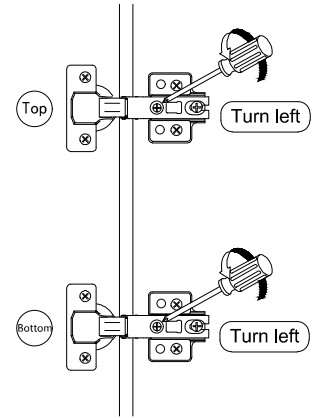
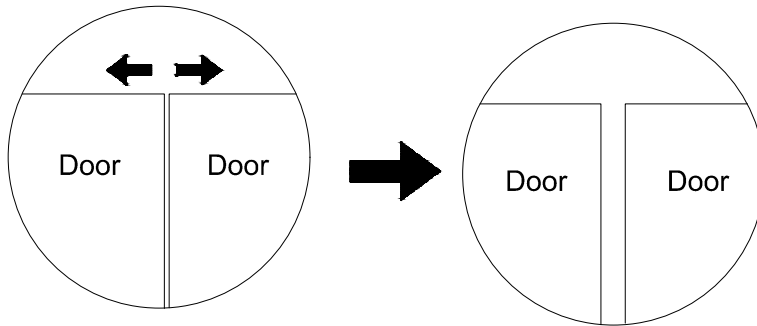

If the gap between the two doors is too small, follow the diagram.

20-D

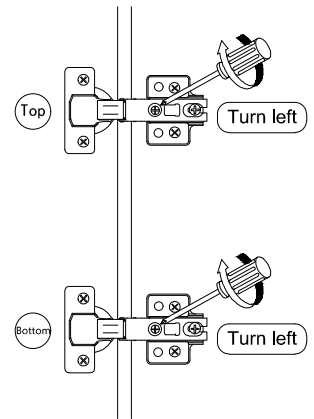
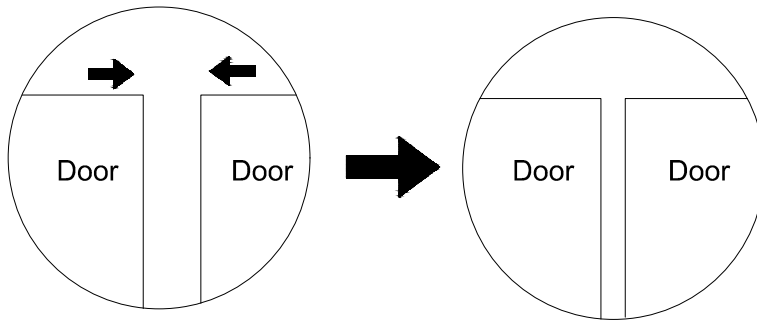

If the gap between the two doors is too large, follow the diagram.

20-E

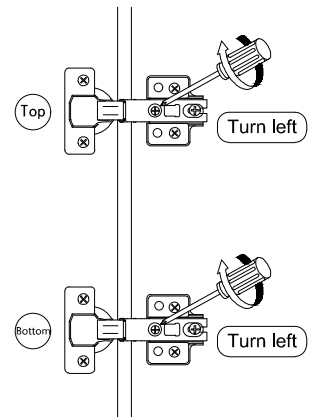
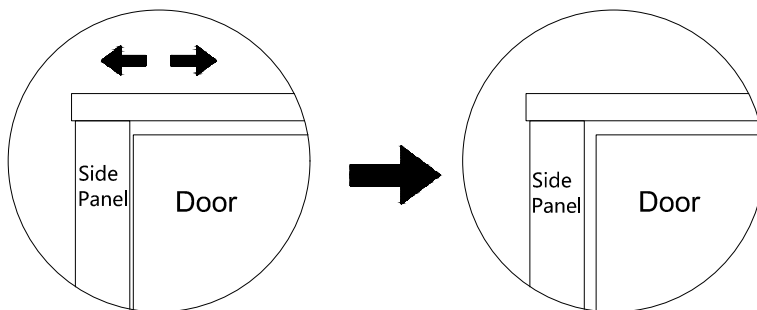

If the gap between the door and the side panel is too small, loose the front screw as shown.

20-F

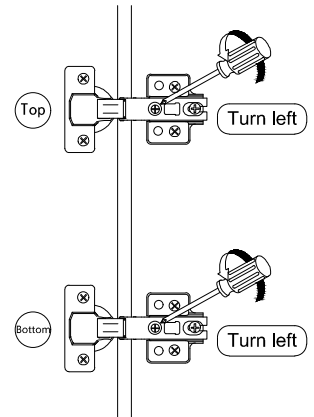
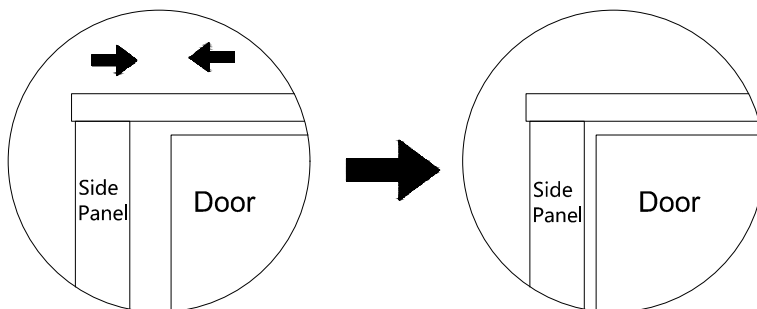

If the gap between the door and the side panel is too large, tighten the front screw as shown.

### 20-G. When door is leaning

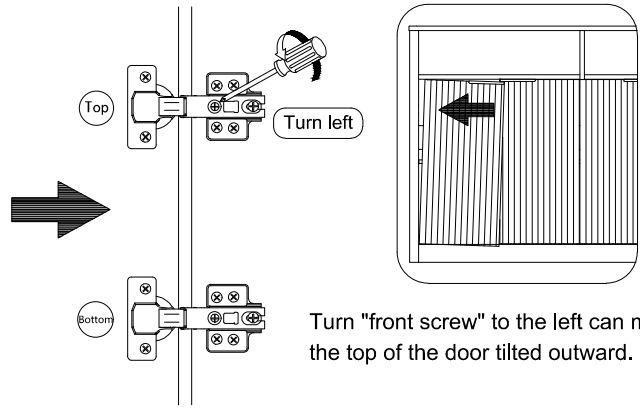
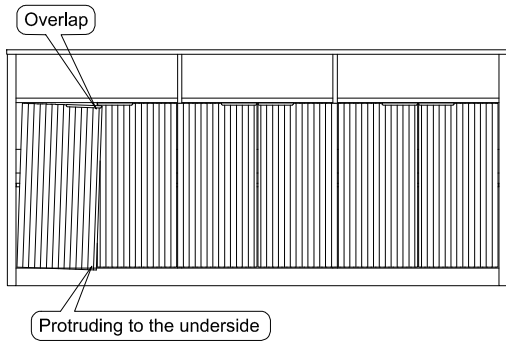

Turn "front screw" to the left can make the top of the door tilted outward.

### 20-H. When door is leaning

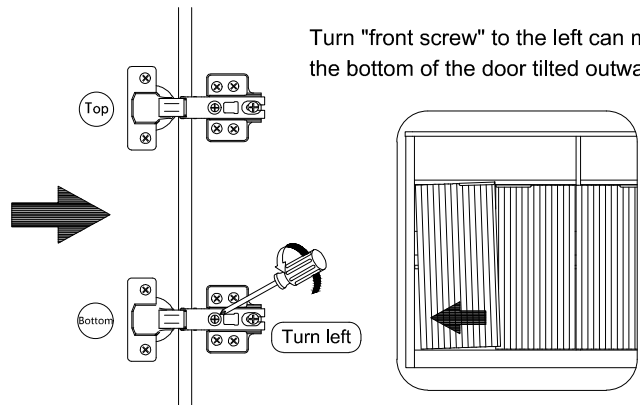
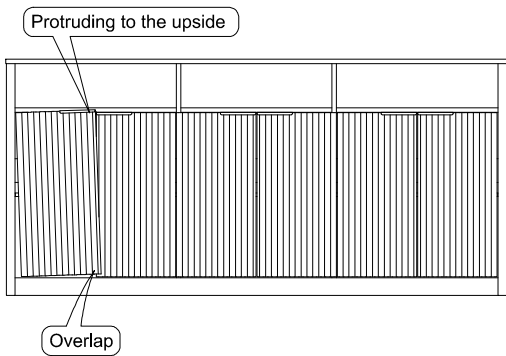

Turn "front screw" to the left can make the bottom of the door tilted outward.

### 20-I. When the door is higher on fop

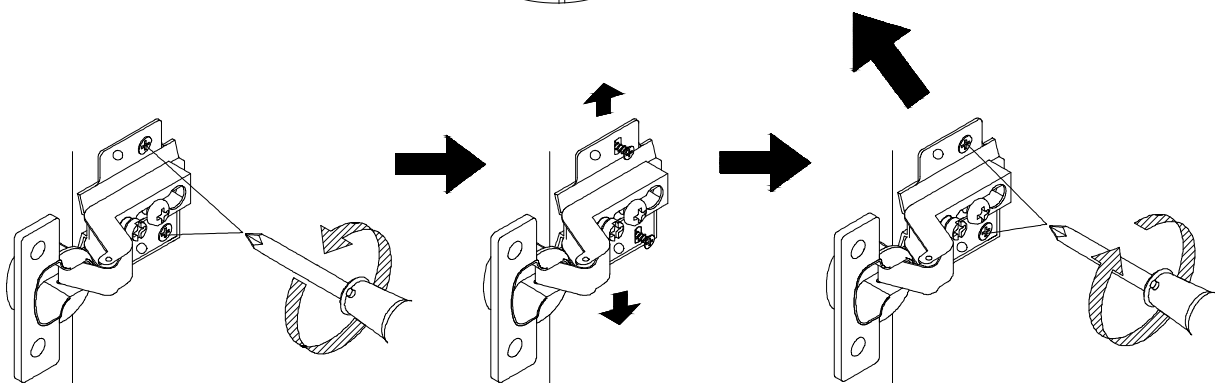
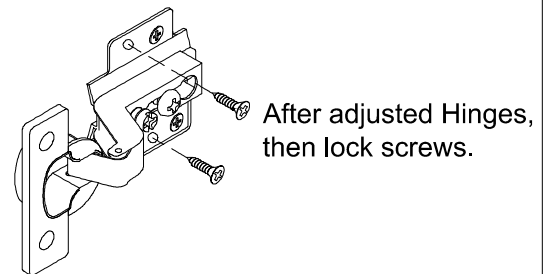
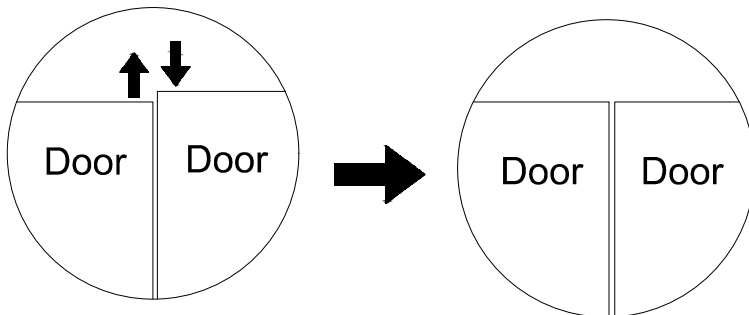

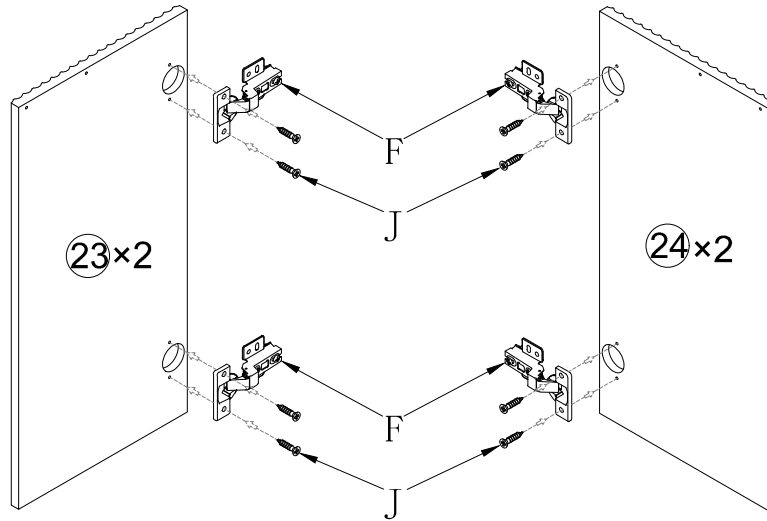

If the doors are not in same level, losse the back screws on wing, then adjust the door up and down, tighten the screws when both doors are in same level. Screw front two screws on wing when all are in place.

# STEP 21

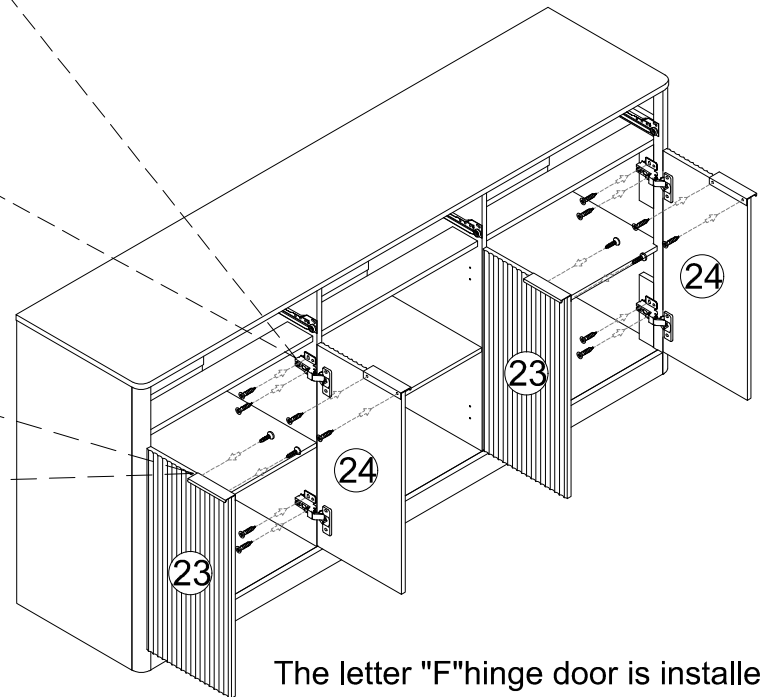
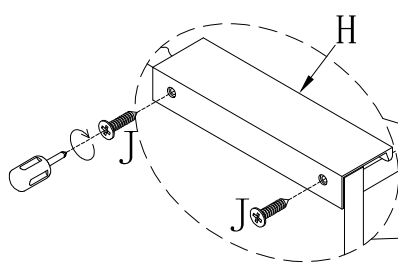
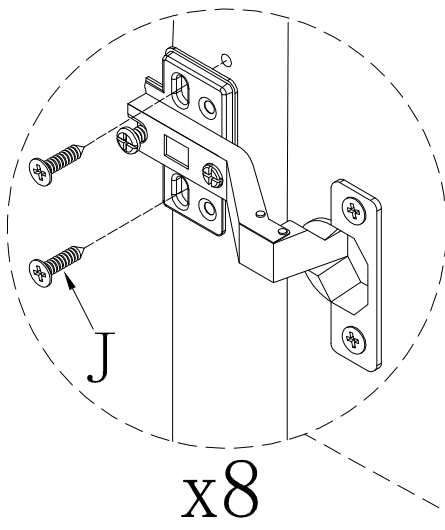

 Before installing the door panels, please study and read the following steps. For possible problems, we have given some suggestions to solve the problems you encounter.

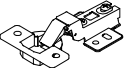
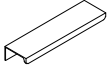

	F×8PCS
	H×4PCS
	J×32PCS

The letter "F" hinge door is installed on both sides of the cabinet.

# STEP 22

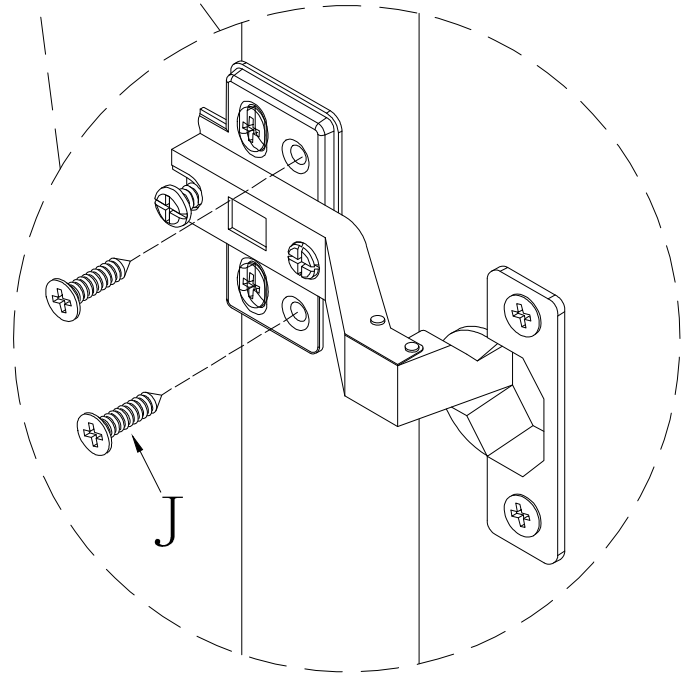
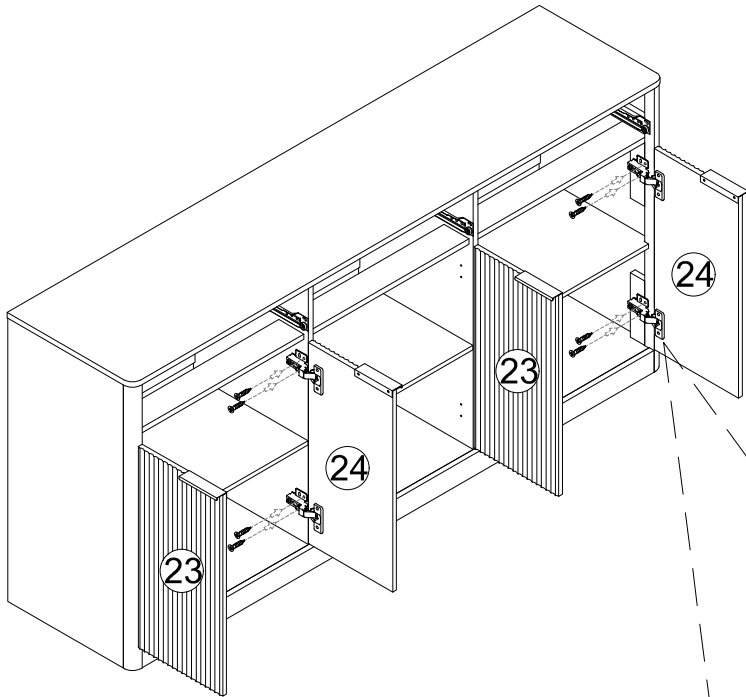

x8



Tighten the screws when both doors are in same level.  
Screw front two screws on wing when all are in place

## NOTE:

If there is a large gap in the installation of the door, you can return to page 19 or page 20 to view the installation video and installation tutorial.



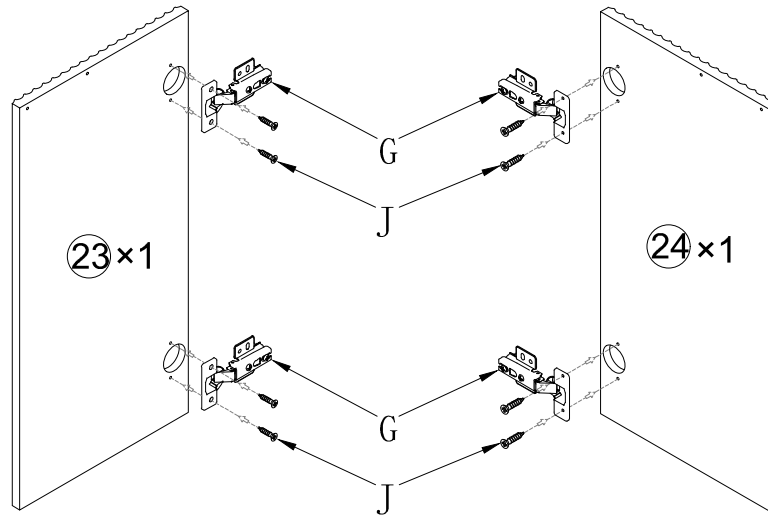

J×16PCS

# STEP 23

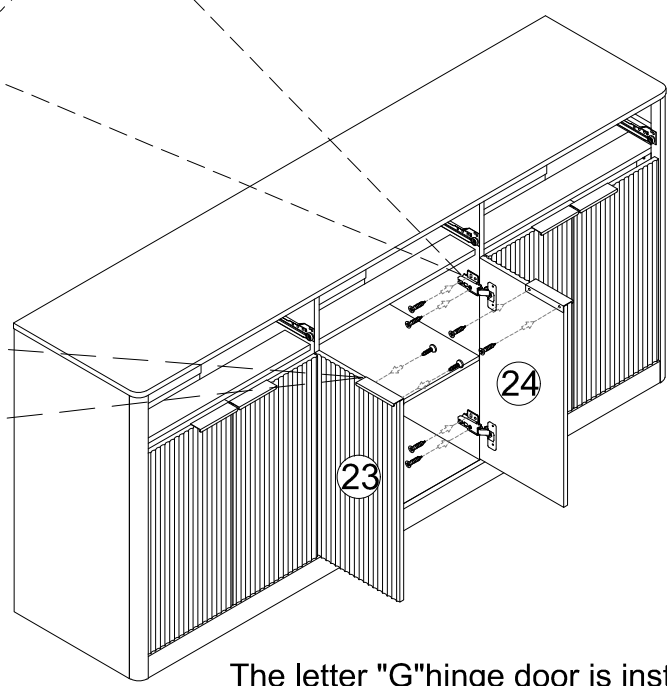
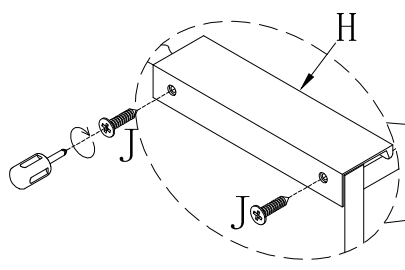
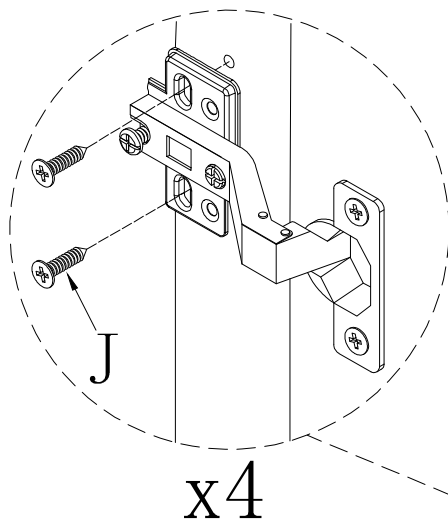

 Before installing the door panels, please study and read the following steps. For possible problems, we have given some suggestions to solve the problems you encounter.

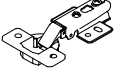

	G×4PCS
	H×2PCS
	J×20PCS

The letter "G" hinge door is installed on both sides of the cabinet.

# STEP 24

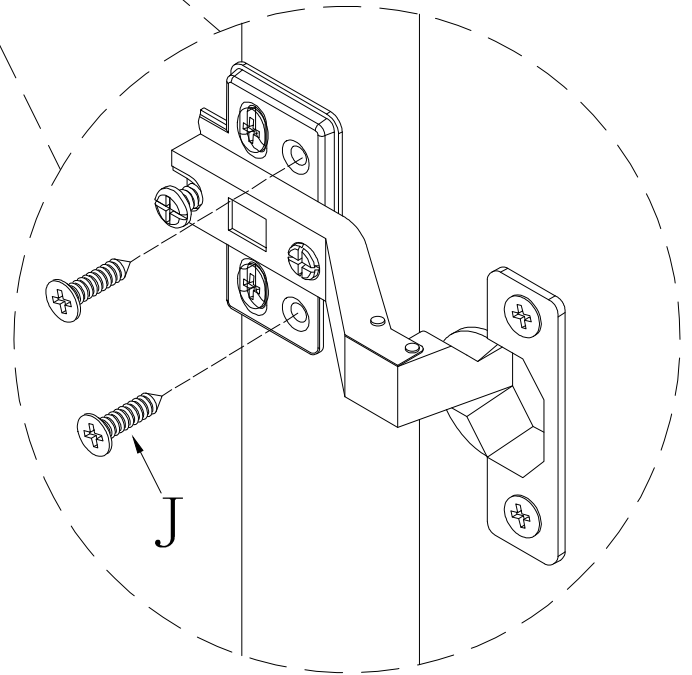
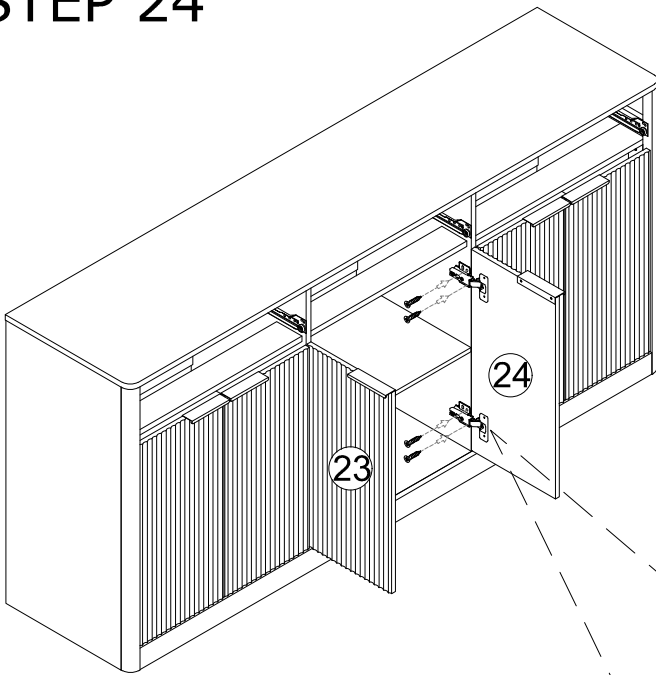

 Tighten the screws when both doors are in same level.  
Screw front two screws on wing when all are in place

**NOTE:**  
If there is a large gap in the installation of the door, **x4**  
you can return to page 19 or page 20 to view the  
installation video and installation tutorial.



# STEP 25

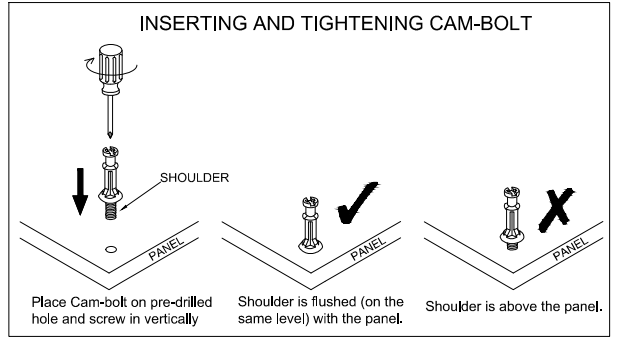
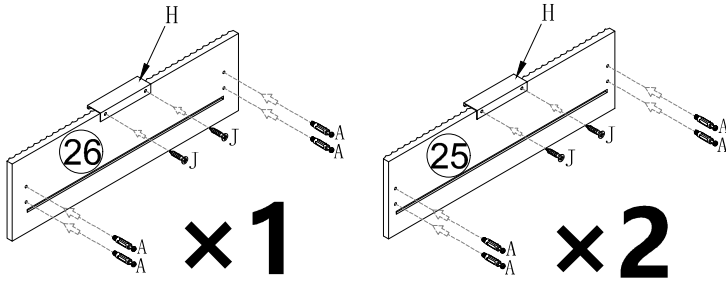

**!** Align the arrow on the Cam-lock to the Cam-bolt head and insert the Cam-lock. Ensure Cam-lock is fully inserted.

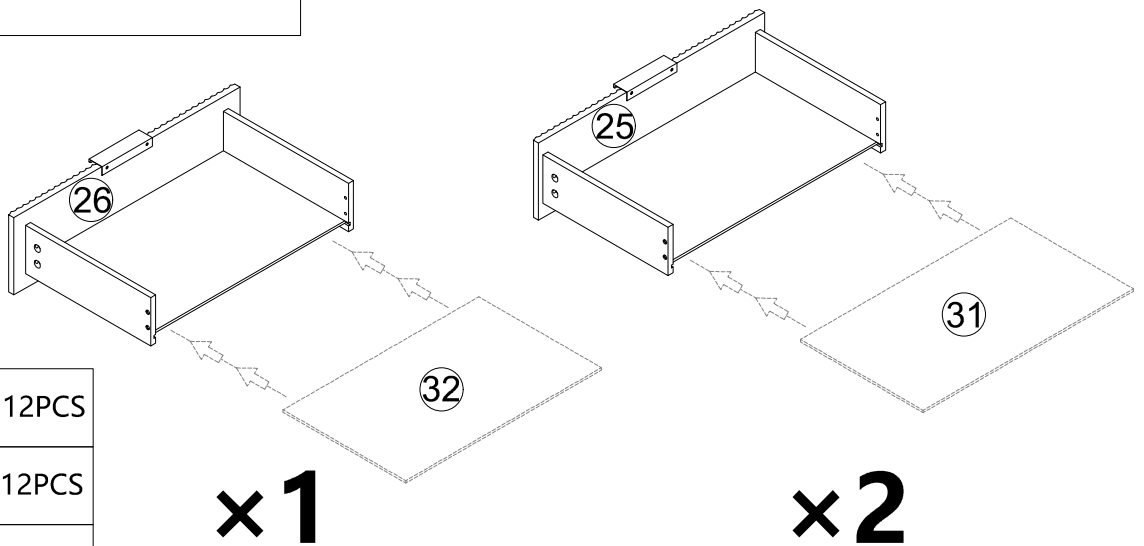
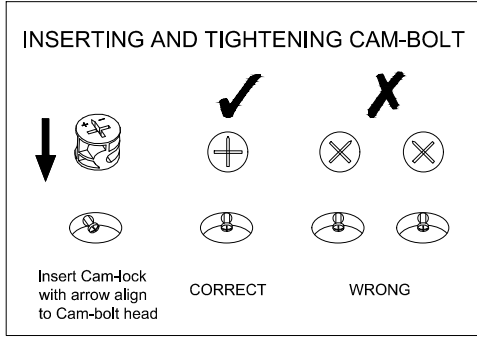
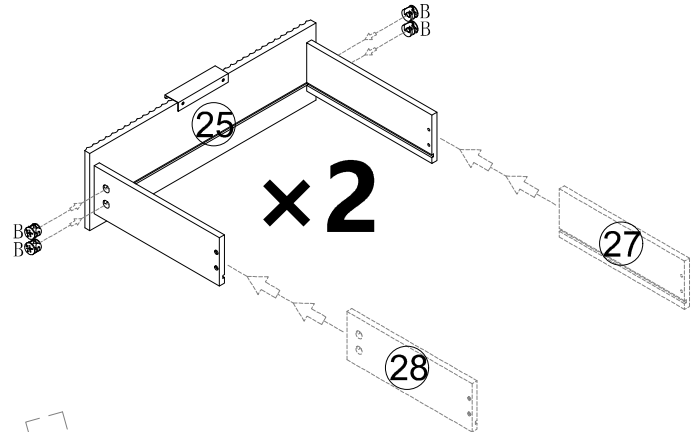
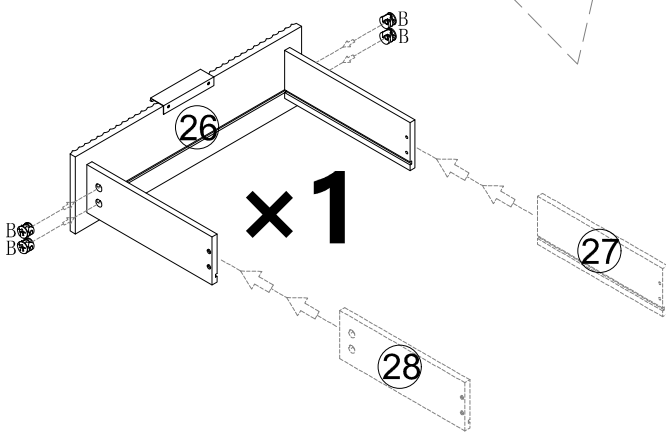

	A×12PCS
	B×12PCS
	H×3PCS
	J×6PCS

# STEP 26

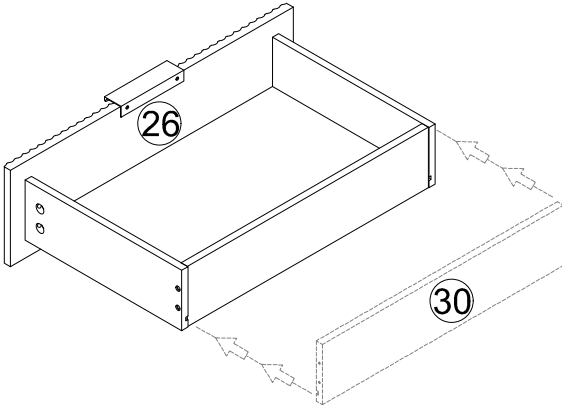

**x1**

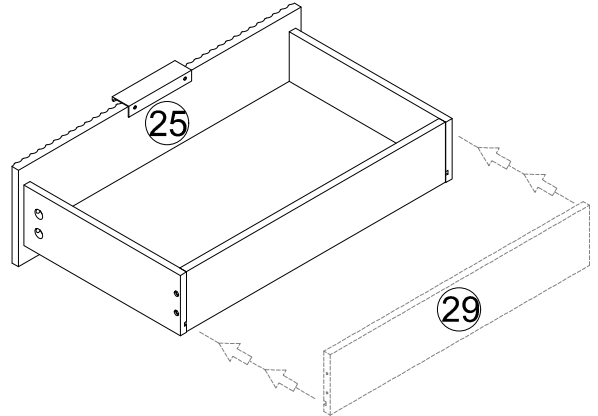

**x2**

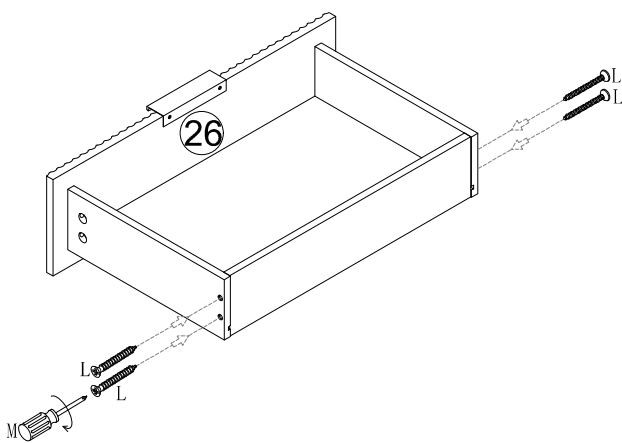
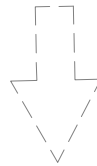

**x1**

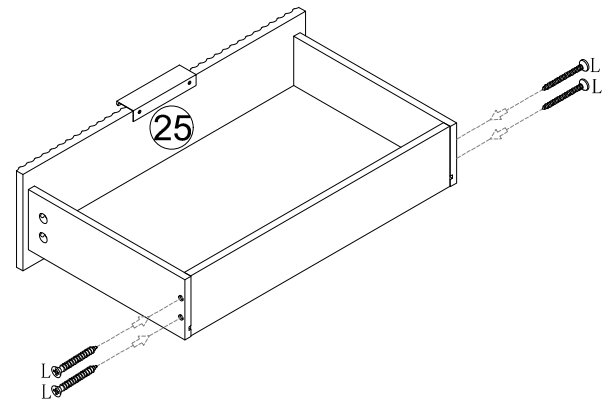

**x2**

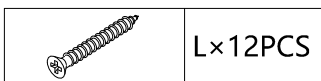

# STEP 27

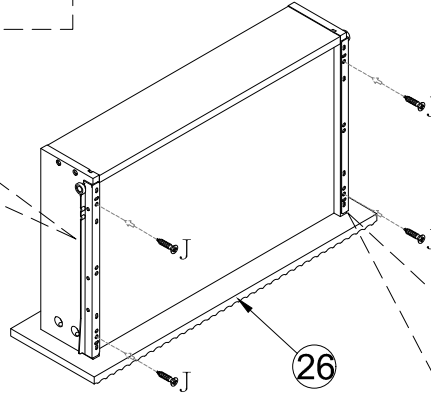
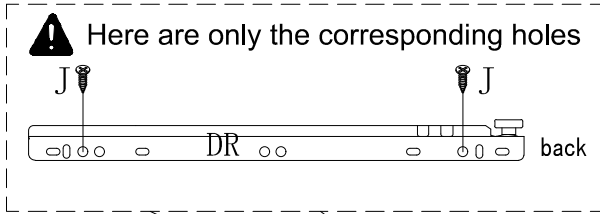

**×1**

	E×2PCS
	J×4PCS

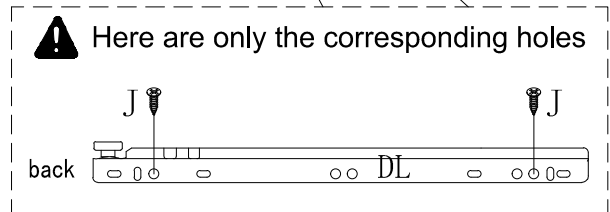

# STEP 28

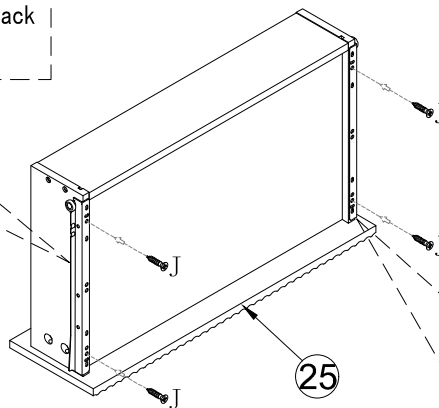
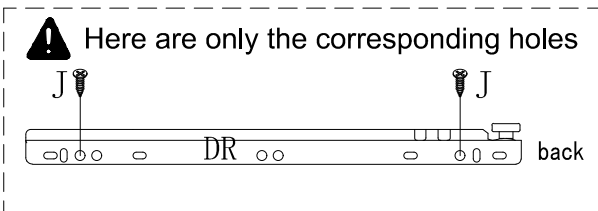

**×2**

	E×4PCS
	J×8PCS

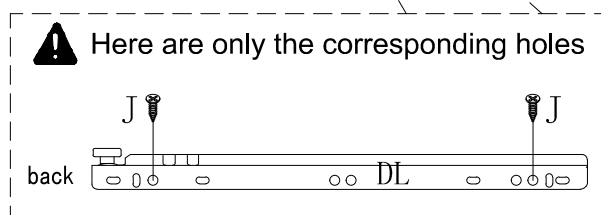

## STEP 29

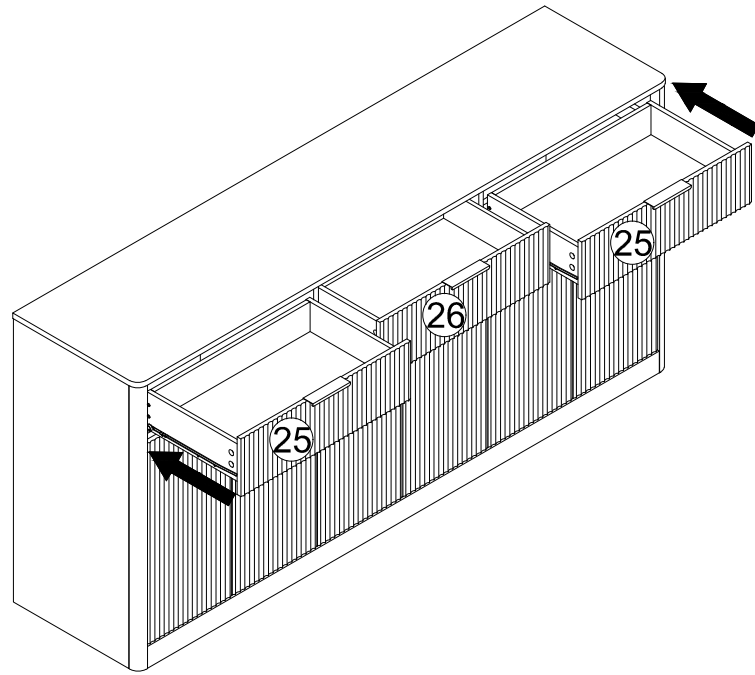

## STEP 30

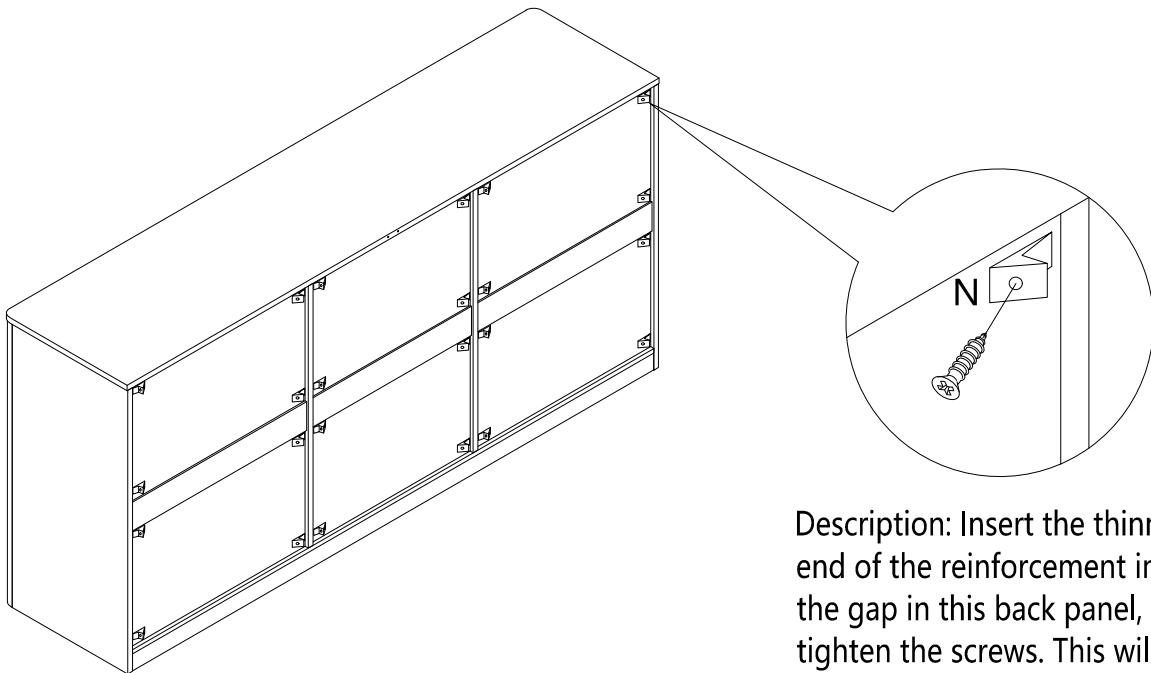

Description: Insert the thinner end of the reinforcement into the gap in this back panel, then tighten the screws. This will make the cabinet more stable.



