









ASSEMBLY INSTRUCTIONS & PARTS IDENTIFICATION COCKTAIL TABLE

Thank you for purchasing this quality product. Be sure to check all packing material carefully for small parts that may have come loose inside the carton during shipment.

| Parts key | | | |
|-----------|------|-------|-----------------|
| No | Code | Q'ty | Description |
| 1 | A | 1 Pc | Storage Box |
| 2 | B | 4 Pcs | Leg |
| 3 | C | 3 Pcs | Drawer Complete |
| 4 | D | 1 Pc | Shelf |
| 5 | E | 4 Pcs | Caster |
| 6 | F | 6 Set | Pull w/Screw |

| Hardware Kit | | |
|--------------|---|--------|
| No | Description | Q'ty |
| A |  Bolt Ø7.8 x 60 | 12 pcs |
| B |  Lock washer Ø8.5 | 12 pcs |
| C |  Flat washer Ø8.5 | 12 pcs |
| D |  Allen key | 1 pc |
| E |  Pull | 6 pcs |
| F |  Wooden Screws Ø4 x 20mm | 12 pcs |
| G |  Caster | 4 pcs |
| H |  Screw Ø4 x 20mm | 16 pcs |

STEP 1:

- Carefully lay the Storage box upside down on a smooth flat surface to prevent scratches.
- Attach each Leg assembly to Storage box as shown in illustration.
- Insert a Bolt (A) with Flat washer (C), Lock washer (B) through holes in wood corner of Storage Box. Do not fully tighten.

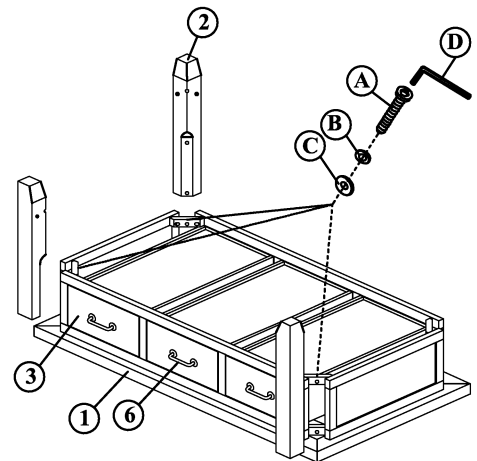

STEP 2:

- Insert the Shelf into designated locations as shown in illustration.
- Insert a Bolt (A) with Flat washer (C), Lock washer (B) through holes in wood corner of Shelf. Fully tighten all bolts with Allen key (D).

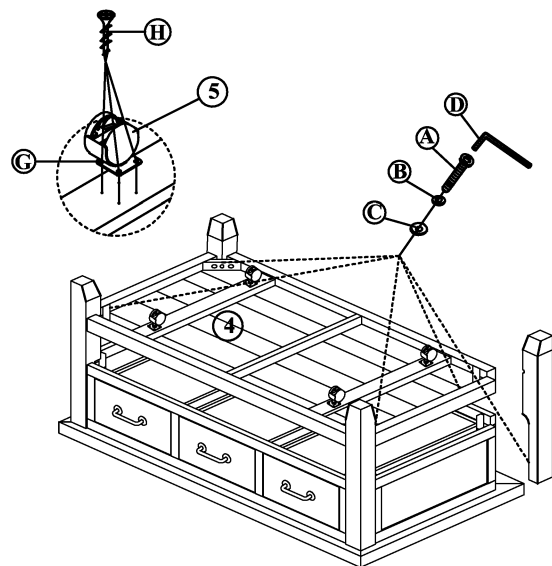

STEP 3:

- Attach Caster (G) to the drawer using screw provided, tighten screw using a phillipshead screwdriver (not provided).
- Carefully turn Cocktail Table upright.

