

ASSEMBLY INSTRUCTION

TIPS

1. Please read the instructions fully before assembly. These instructions include important information which could ensure correct assembly. We have been working on providing high quality products for you. However, in the rare instance that your product is defective, missing parts or there are some issues, please don't hesitate to contact our customer service to submit parts requirements, assembly suggestion, or warranty claims, and we will give the best solution as soon as possible. If necessary, we need you to provide some more clear pictures of the issue.

2. Insert the screws in holes and tighten the screws, but not too tight, 70%~80% is ok, finally tighten all the screws. If some issues happened that some screws can not target to the hole or some parts are difficult to install, please adjust the tightness of the screws.

3. 2 people are recommended to finish.

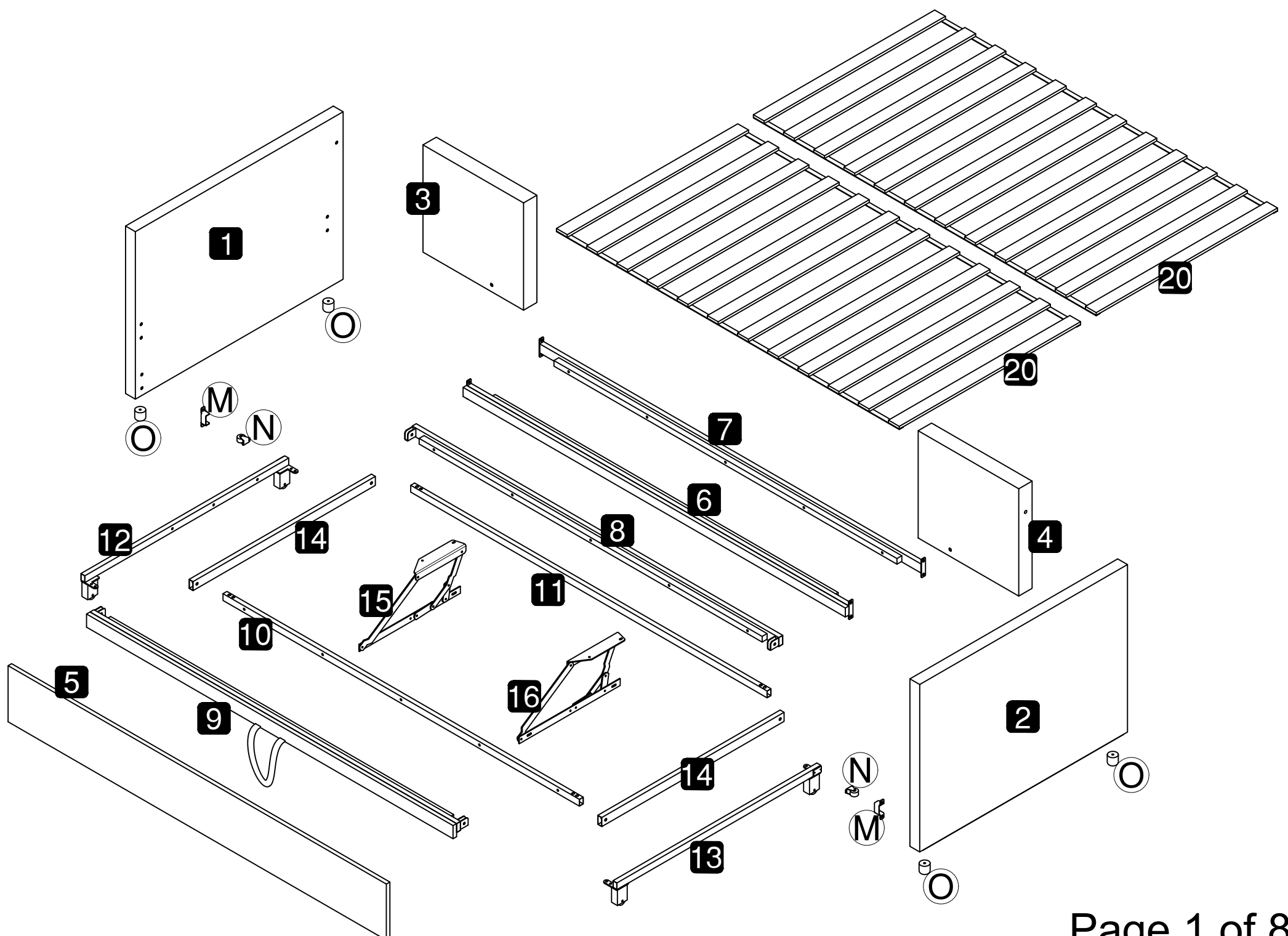
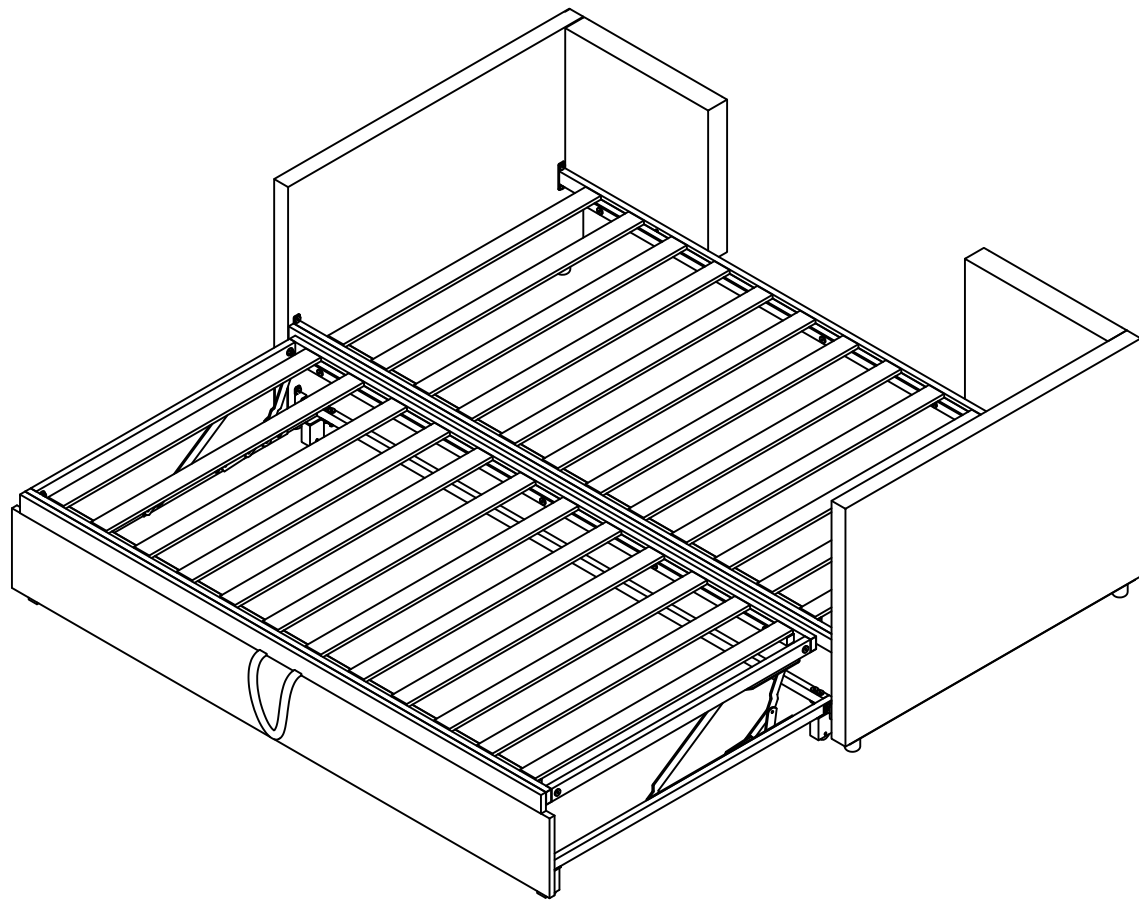



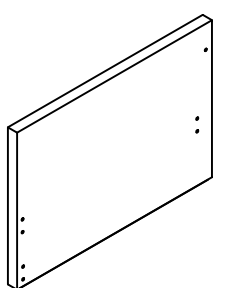
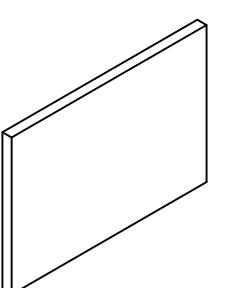
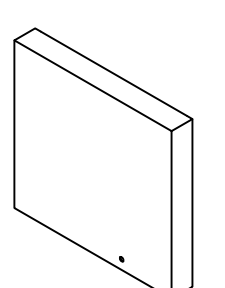
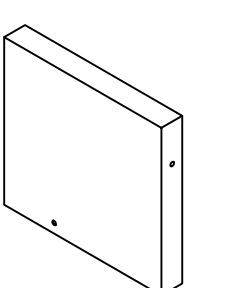
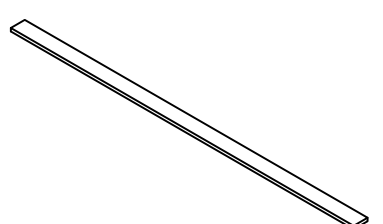

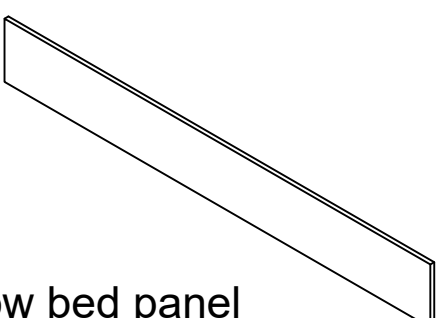
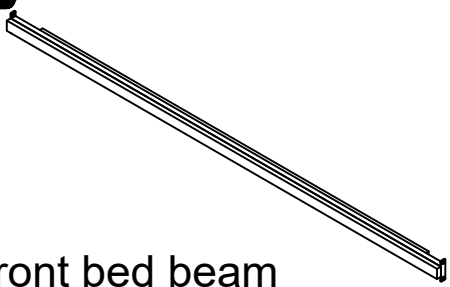
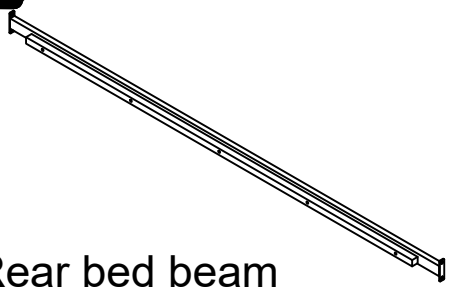
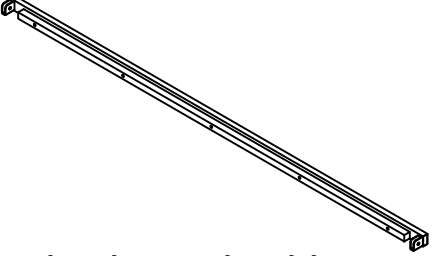
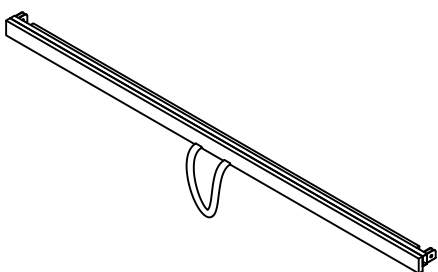
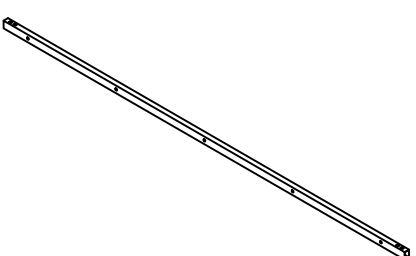
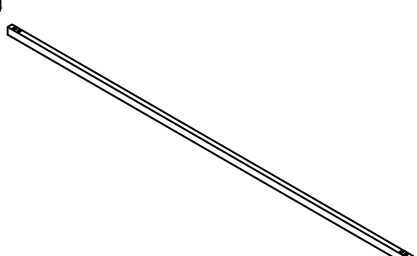
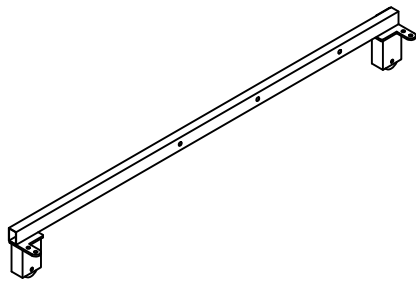
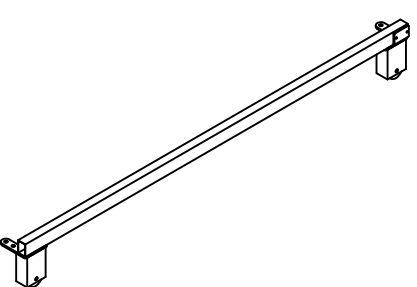
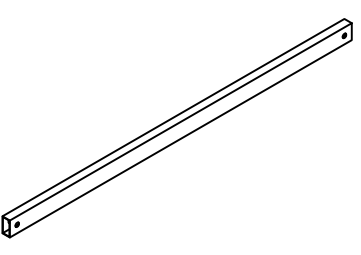
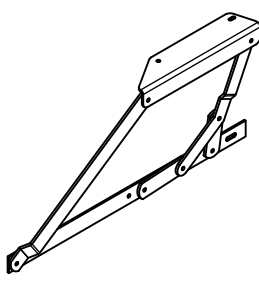
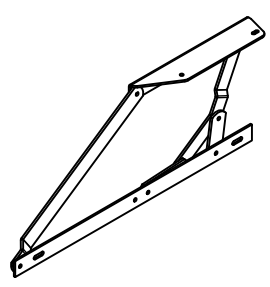

Part List

<p>1</p>  <p>Armrest - L X 1</p>	<p>2</p>  <p>Armrest - R X 1</p>	<p>3</p>  <p>Backrest - L X 1</p>	<p>4</p>  <p>Backrest - R X 1</p>
<p>20</p>  <p>Slats X 24</p>			

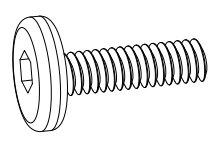
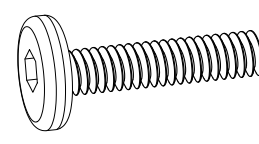
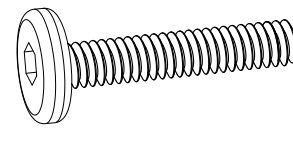
Part List

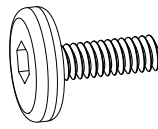
<p>5</p>  <p>Tow bed panel X 1</p>	<p>6</p>  <p>Front bed beam X 1</p>	<p>7</p>  <p>Rear bed beam X 1</p>	<p>8</p>  <p>Tow bed rear bed beam X 1</p>
<p>9</p>  <p>Tow bed front bed beam X 1</p>	<p>10</p>  <p>Tow bed front tube X 1</p>	<p>11</p>  <p>Tow bed rear pipe X 1</p>	<p>12</p>  <p>Tow bed side pipe - L X 1</p>
<p>13</p>  <p>Tow bed side pipe - R X 1</p>	<p>14</p>  <p>Tow bed upper side pipe X 2</p>	<p>15</p>  <p>Lift Mechanism - L X 1</p>	<p>16</p>  <p>Lift Mechanism - R X 1</p>

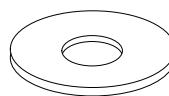
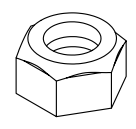
Part List

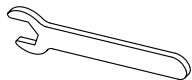
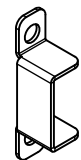
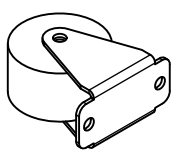
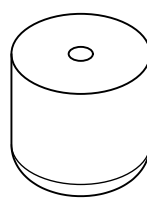
<p>A</p>  <p>Bolts (M8x20mm) X 12</p>	<p>B</p>  <p>Bolts (M8x30mm) X 4</p>	<p>C</p>  <p>Bolts (M8x40mm) X 12</p>	<p>D</p>  <p>Bolts (M6x35mm) X 9</p>
<p>E</p>  <p>Bolts (M6x16mm) X 10</p>	<p>F</p>  <p>Bolts (M4x10mm) X 4</p>	<p>G</p>  <p>Flat Washer X 8</p>	<p>H</p>  <p>Non-slip nuts (M8) X 4</p>
<p>K</p>  <p>Allen Key X 1</p>	<p>L</p>  <p>Spanner X 1</p>	<p>M</p>  <p>Positioning iron sheet X 2</p>	<p>N</p>  <p>Side wheel X 2</p>
<p>O</p>  <p>Legs X 4</p>			

Step 1

Using an Allen key (K) and bolt (E), secure the Legs (O) to the armrest (1&2).
(Mit einem Inbusschlüssel (K) und Schraube (E) befestigen Sie die Beine (O) an der Armlehne (1&2).)

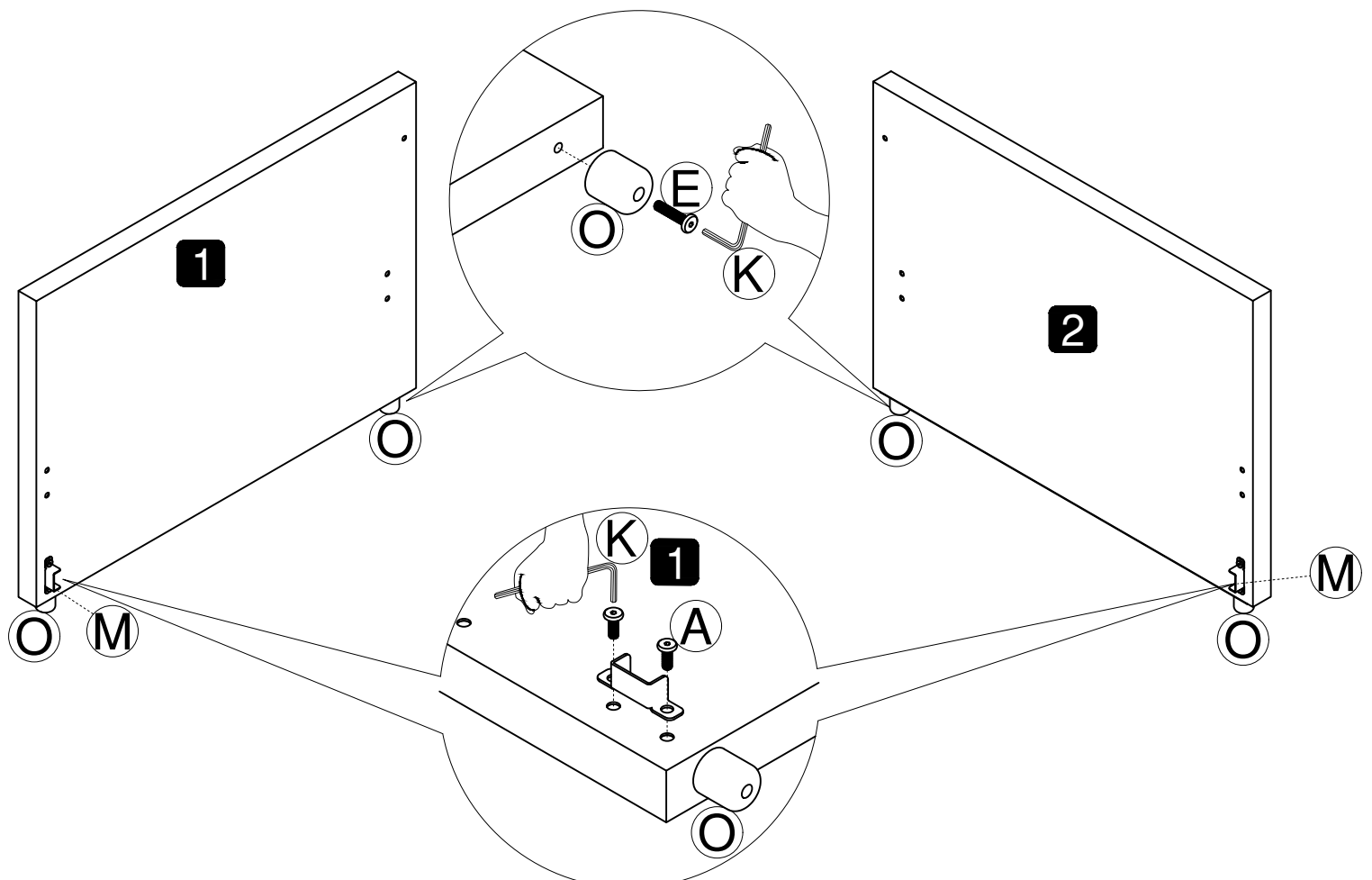
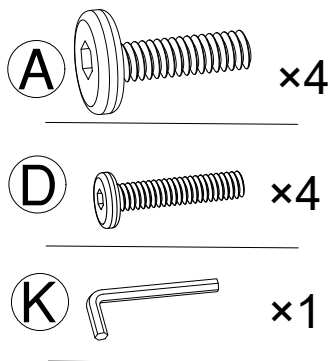

Using an Allen key (K) and bolt (A), secure the Positioning iron sheet (M) to the armrest (1&2), paying attention to the direction, with the opening facing inward.

(Mit einem Inbusschlüssel (K) und Schraube (A) befestigen Sie das Positioniereisenblatt (M) an der Armlehne (1&2), achten Sie auf die Richtung, wobei die Öffnung nach innen zeigt.)

Step 2

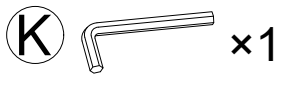
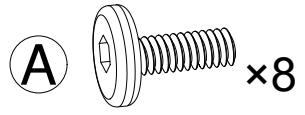

Use the hexagonal wrench (K) and bolt (A) to connect the bed beam (6&7) to the handrail (1&2). Pay attention to the direction, as shown in the figure. The convex Flat noodles faces inward and the velcro faces upward.

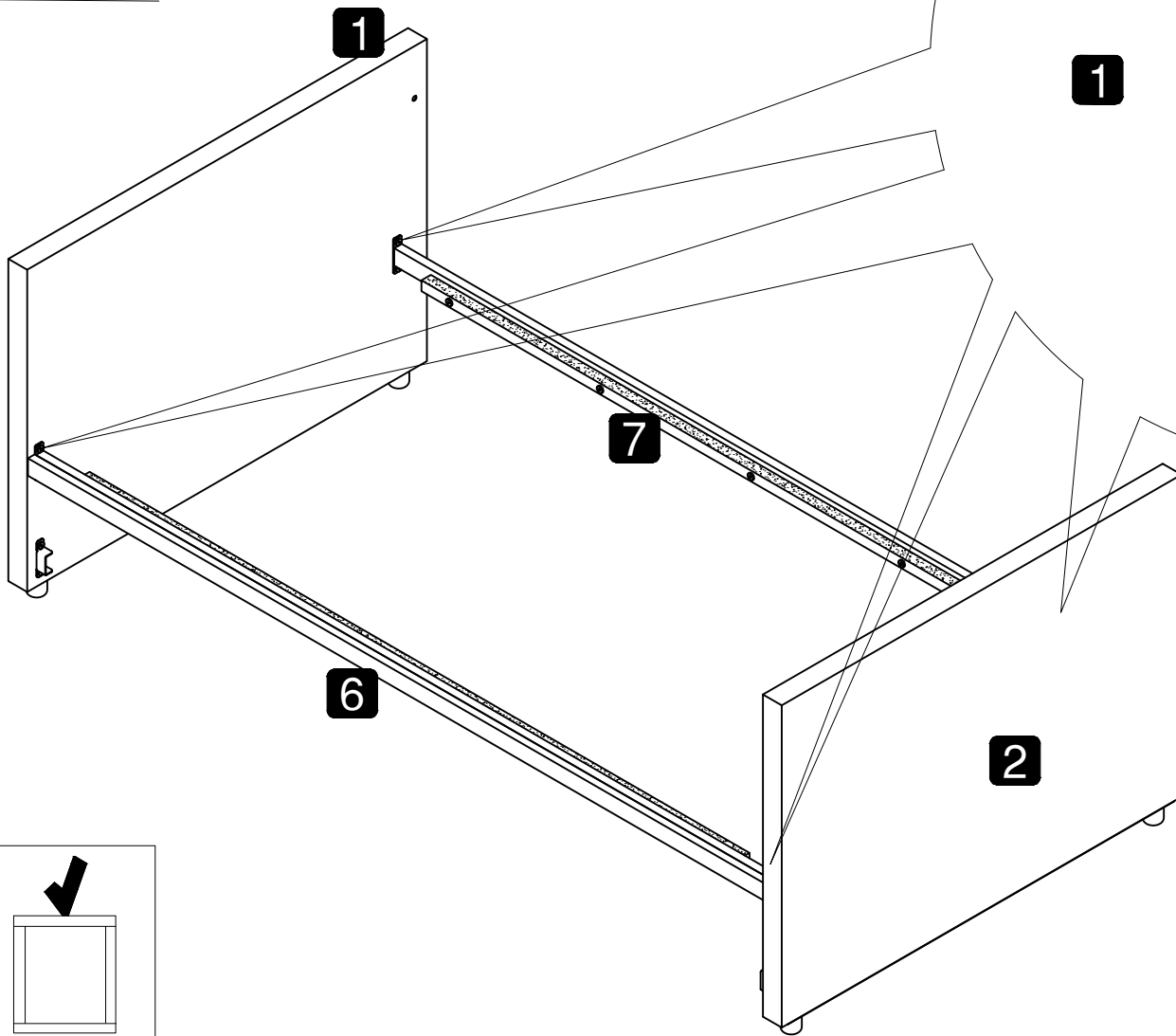

(Verwenden Sie den Sechskantschlüssel (K) und die Schraube (A), um den Bettbalken (6&7) mit dem Handlauf (1&2) zu verbinden. Achten Sie auf die Richtung, wie in der Abbildung gezeigt. Die konvexen flachen Nudeln zeigen nach innen und der Klettverschluss nach oben.)

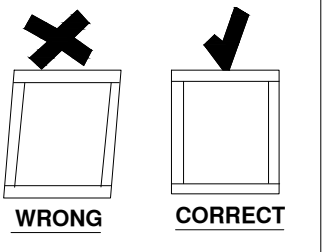

Step 3

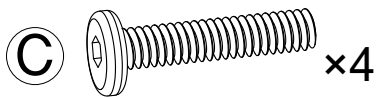

Connect the Backrest (3&4) to the armrest (1&2) using an Allen key (K) & bolt (C) & flat washer (G).

(Verbinden Sie die Rückenlehne (3&4) mit der Armlehne (1&2) mit einem Inbusschlüssel (K) & bolt (C) & Flat Unterlegscheibe (G).)

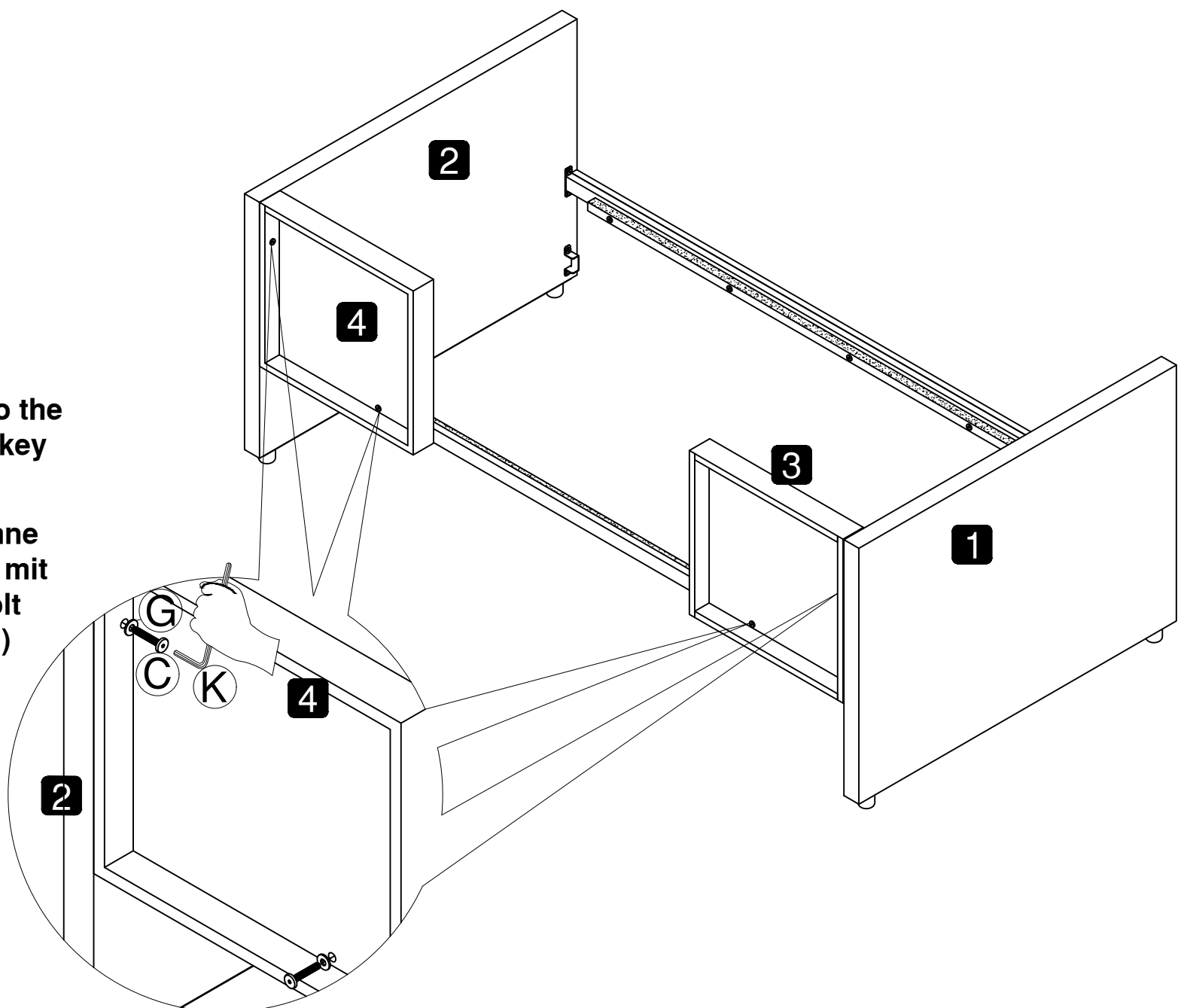

Step 4

F  x4

K  x1

Using an Allen key K & bolt (F), secure the Side wheel (N) to the traction bed side tubes (12 & 13).

(Mit einem Inbusschlüssel K-Bolzen (F) befestigen Sie das Seitenrad (N) an den Seitenrohren des Traktionsbetts (12 & 13).)

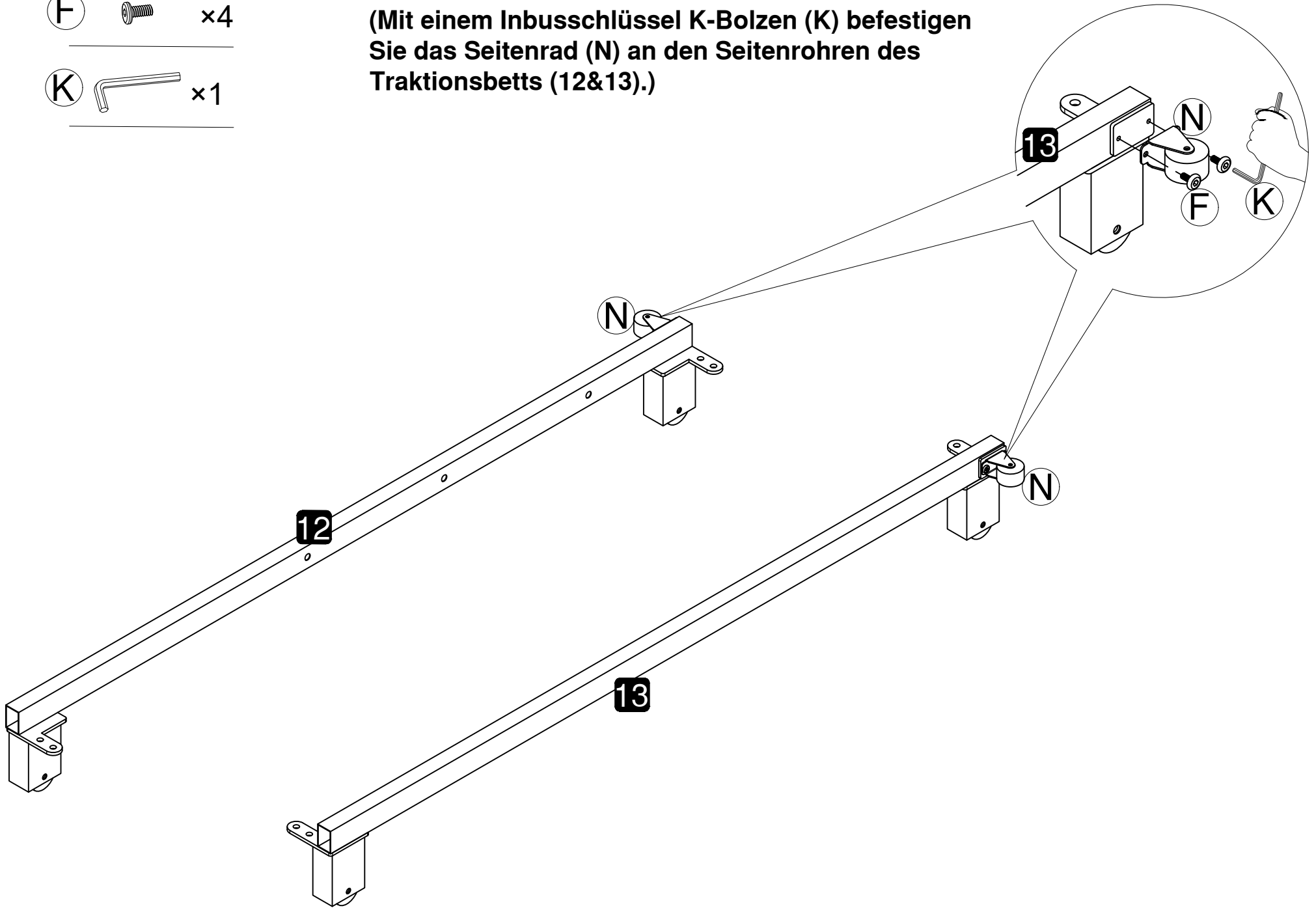

Step 5

C  x8

K  x1

Using an Allen key K & bolt C, connect the Tow bed front tube (10) & Tow bed rear pipe (11) to the Tow bed side pipe (12 & 13).

Pay attention to the direction, as shown in the figure, The Tow bed rear pipe (11) of the traction bed is located on one side of the mounting side wheel (N).

(Verbinden Sie mit einem Inbusschlüssel K und Schraube C das vordere Rohr (10) und das hintere Rohr (11) des Traktionsbetts mit den Seitenrohren (12 und 13) des Traktionsbetts.

Achten Sie auf die Richtung, wie in der Abbildung gezeigt, befindet sich das hintere Rohr (11) des Traktionsbetts auf der Seite des Rades (N) auf der Montage-seite.)

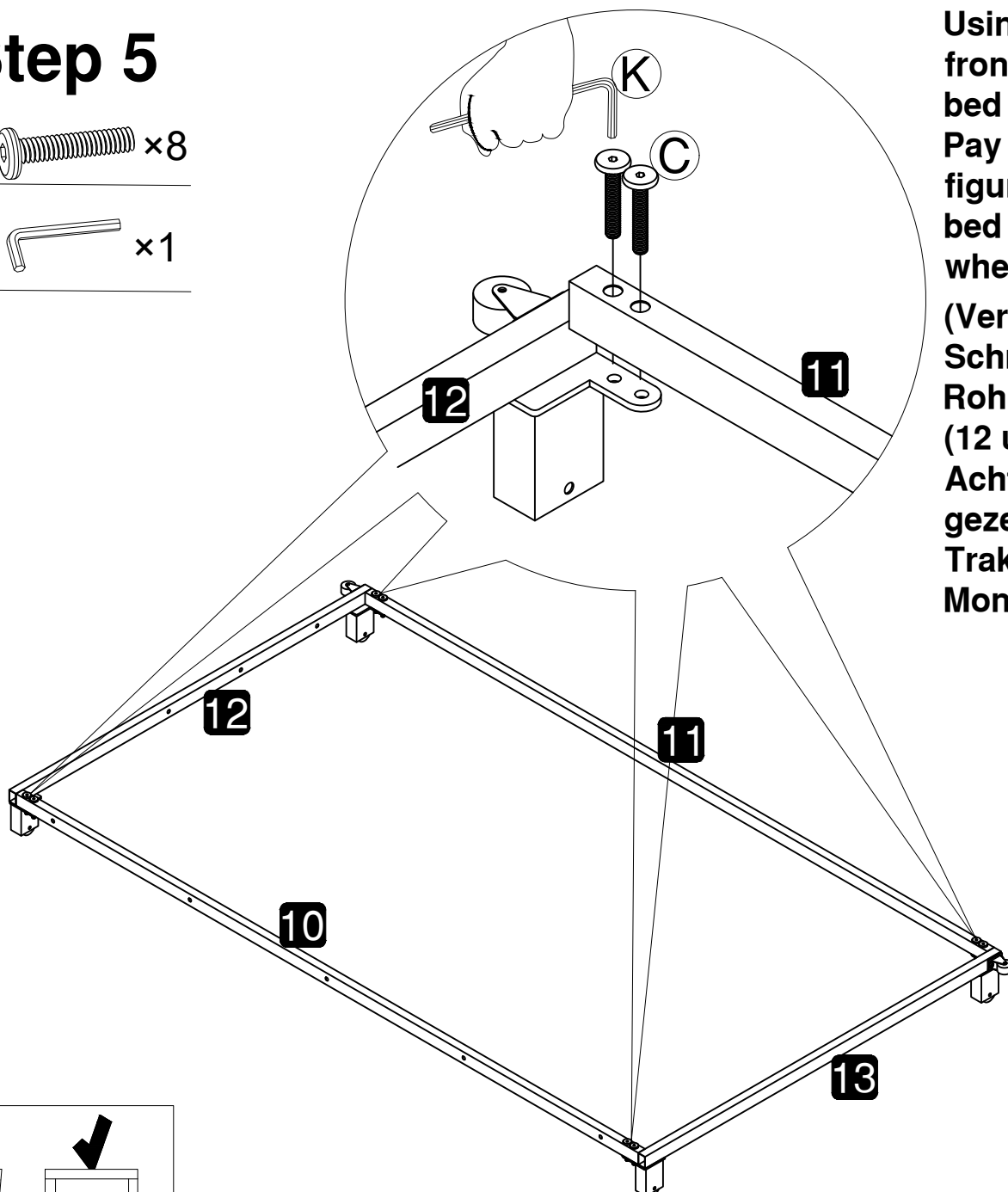



WRONG

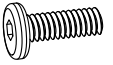

CORRECT

Step 6

E  x6

K  x1

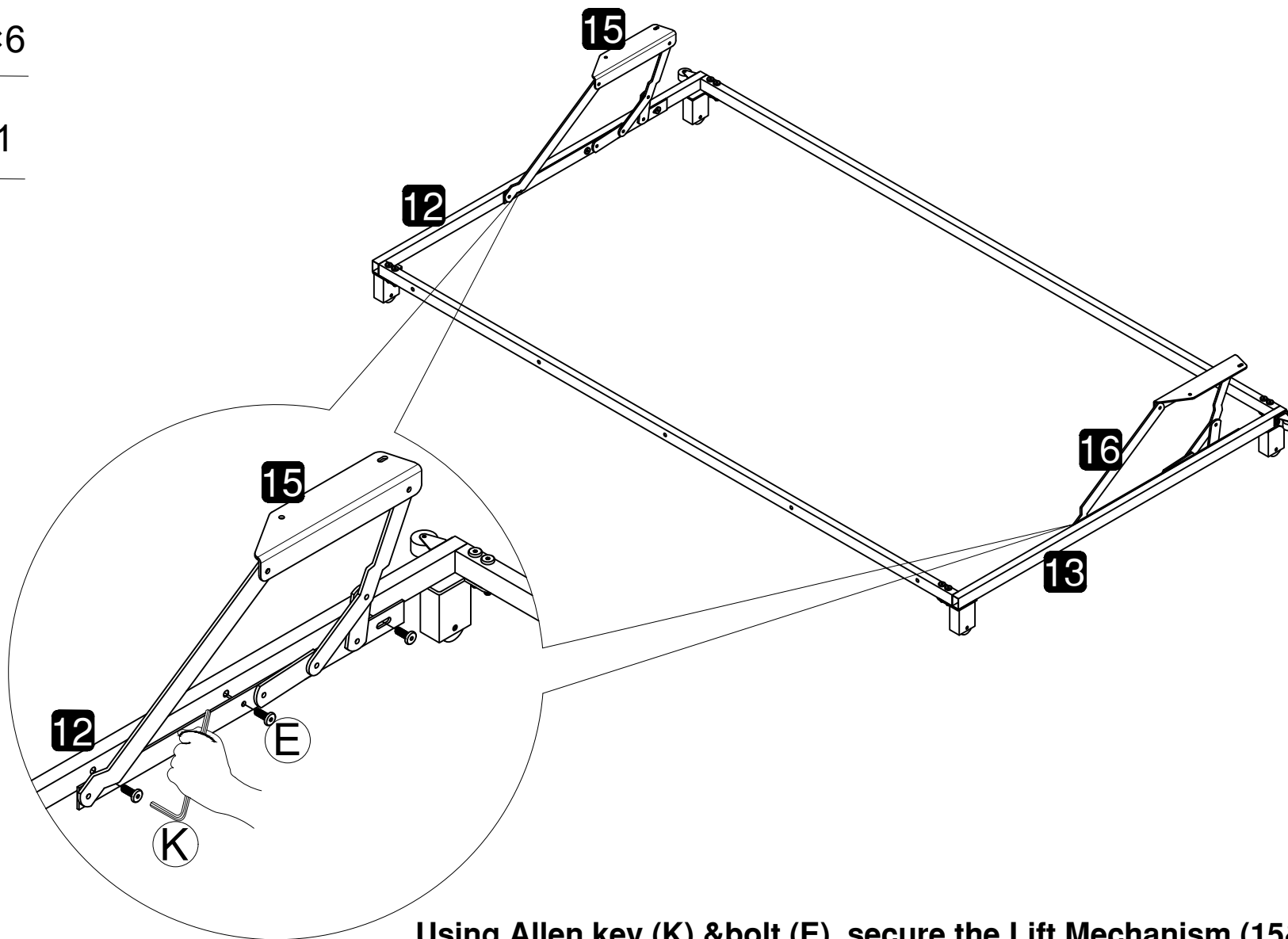

Using Allen key (K) & bolt (E), secure the Lift Mechanism (15&16) to the Tow bed side pipe (12&13).

(Mit Inbusschlüssel(K)&Bolt(E) befestigen Sie den Hebemechanismus (15&16) am Seitenrohr des Abschleppbetts (12&13).)

Step 7

D  x5

K  x1

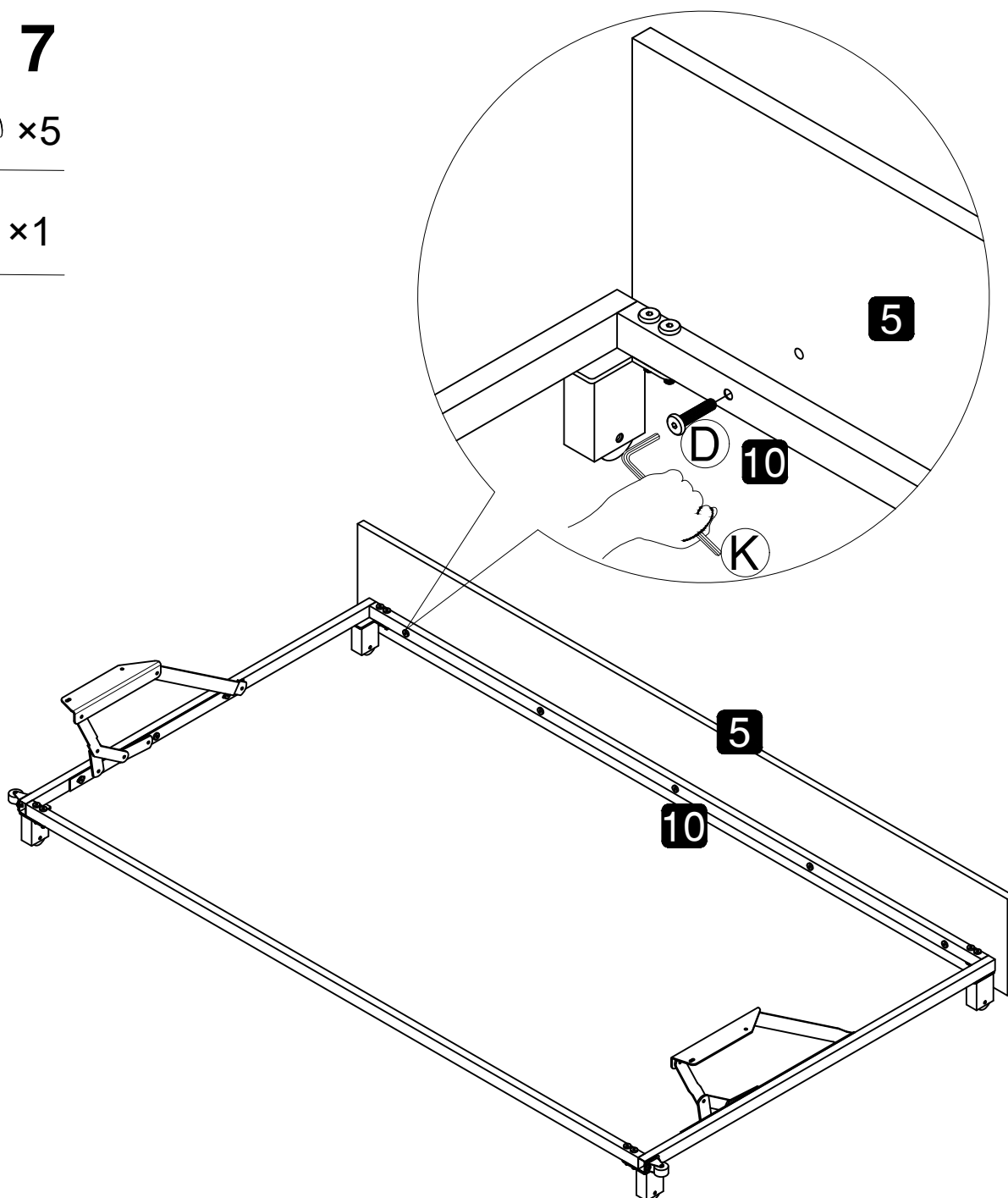

Using an Allen key (K) and bolt (D), connect the Tow bed panel (5) to the Tow bed front tube (10).

(Verbinden Sie mit einem Inbusschlüssel (K) und einer Schraube (D) die Schleppbettplatte (5) mit dem Vorderrohr des Schleppbetts (10).)

Step 8

Bottom view, insert the U-shaped iron plates at both ends of the rear bed beam (8) and the front bed beam (9) of the traction bed into the pipe orifices at both ends of the upper side pipe (14) of the traction bed, and then fasten them using an Allen key (K), an open end wrench (L), bolts (D), flat washers (G), and anti-skid nuts (H).

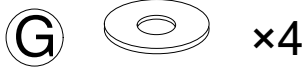
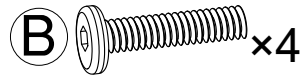

(Führen Sie in der unteren Ansicht die U-förmigen Eisenplatten an beiden Enden des hinteren Bettbalkens (8) und des vorderen Bettbalkens (9) des Zugbettes in die Rohröffnungen an beiden Enden des oberen Seitenrohrs (14) des Zugbettes ein und befestigen Sie sie dann mit einem Inbusschlüssel (K), einem offenen Endschlüssel (L), Schrauben (D), Flachscheiben (G) und Antirutschmuttern (H).)

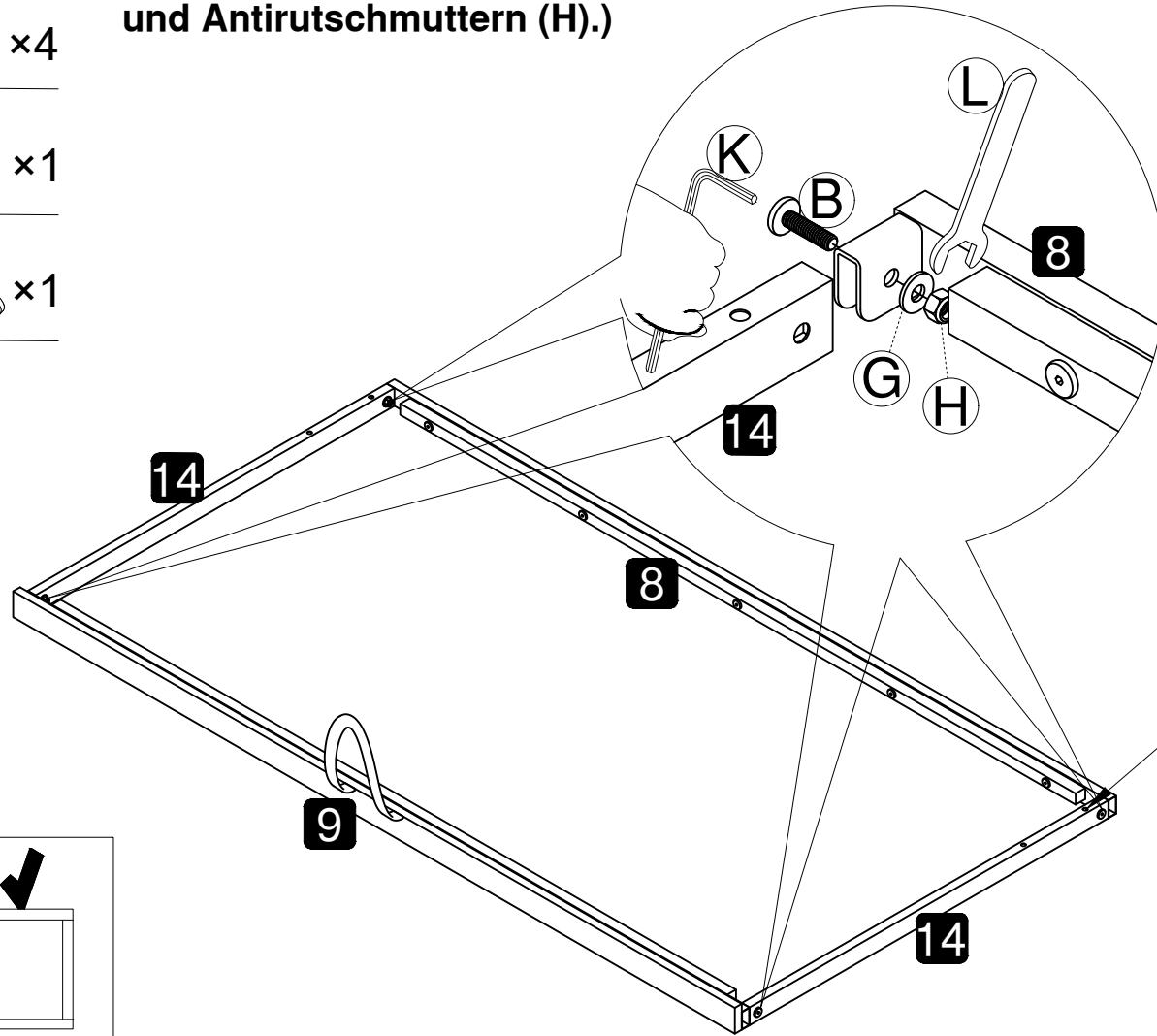

Note the position of the rear bed beam (8) of the traction bed and the front bed beam (9) of the traction bed, as shown in the figure: The rear bed beam (8) of the traction bed is located at the screw hole end of the front tube (14) of the traction bed.

(Beachten Sie die Position des hinteren Bettbalkens (8) des Traktionsbettes und des vorderen Bettbalkens (9) des Traktionsbettes, wie in der Abbildung gezeigt: Der hintere Bettbalken (8) des Traktionsbettes befindet sich am Schraubenlochende des Vorderrohrs (14) des Traktionsbettes.)

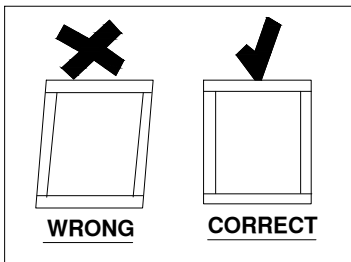

Step 9

Bottom view, connect Lift Mechanism(15&16) to Tow bed upper side pipe(14) using an Allen key (K)&bolt (E).

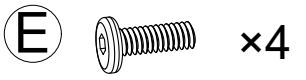

(Aus der unteren Ansicht verwenden Sie einen Inbusschlüssel (K) und Schrauben (E), um die Hebemechanismen (15 und 16) mit den Seitenrohren (14) auf dem Traktionsbett zu verbinden.)

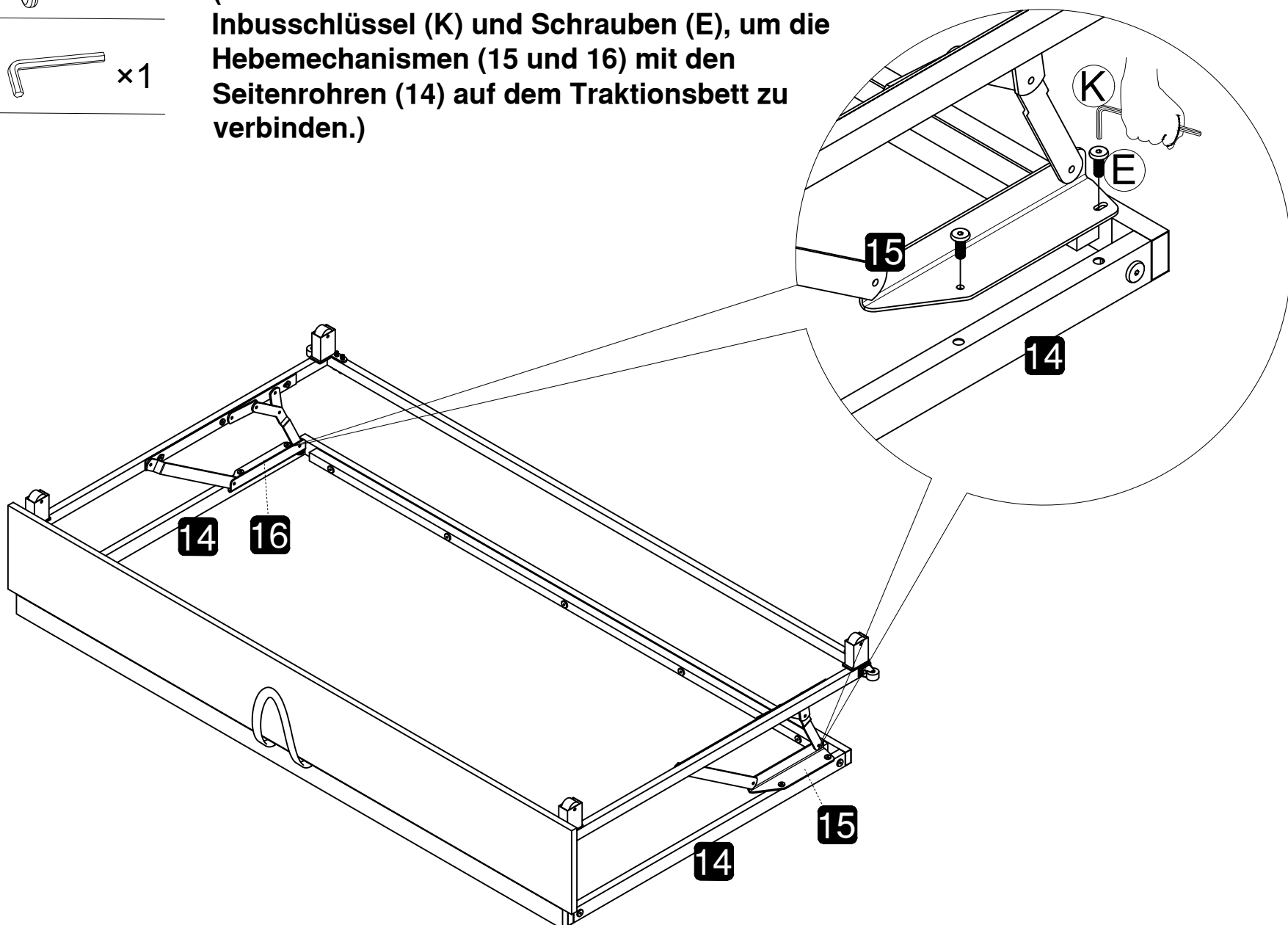

Step 10

Paste slats (20) onto side rails.
(Lamellen (20) auf Seitenschienen kleben.)

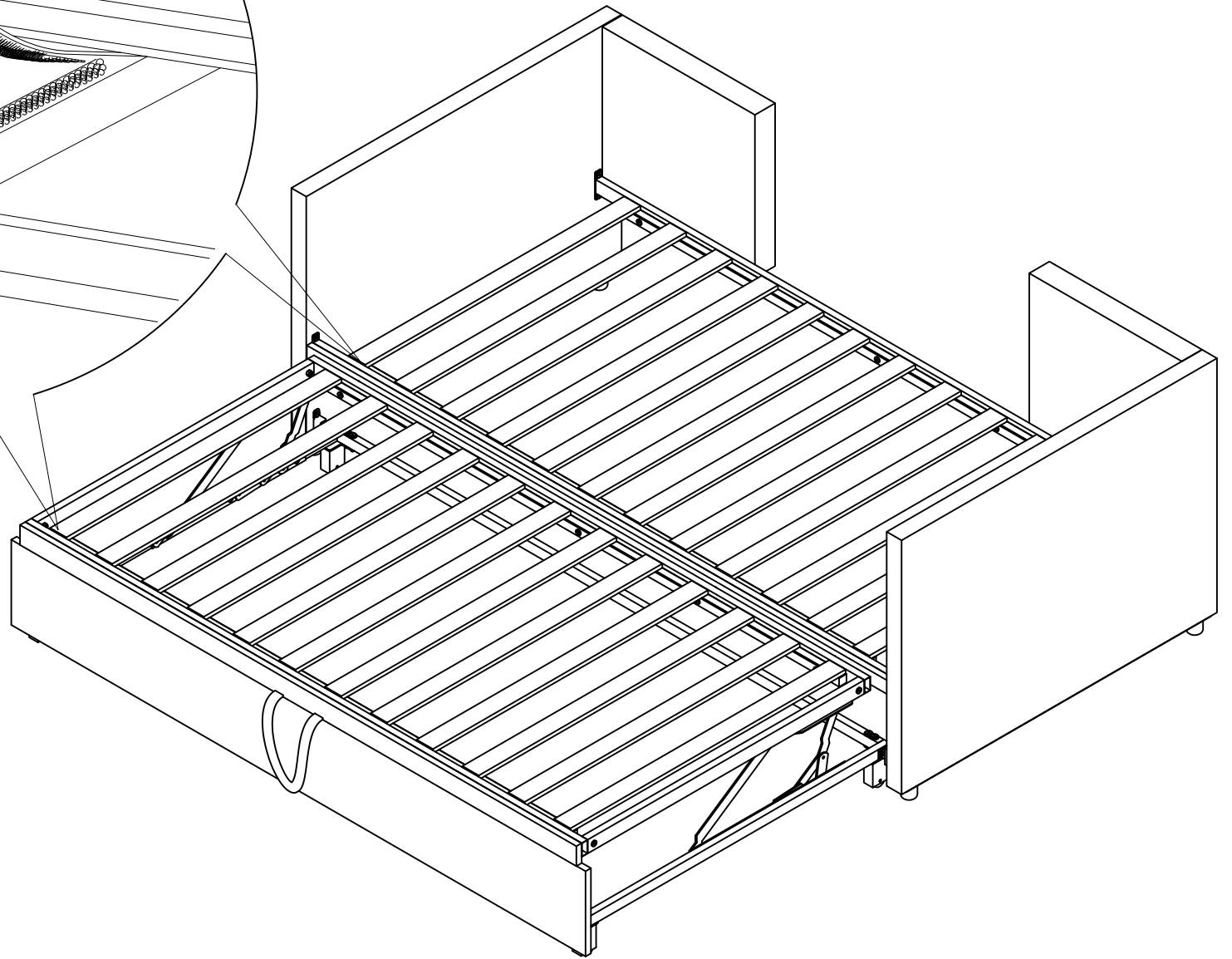
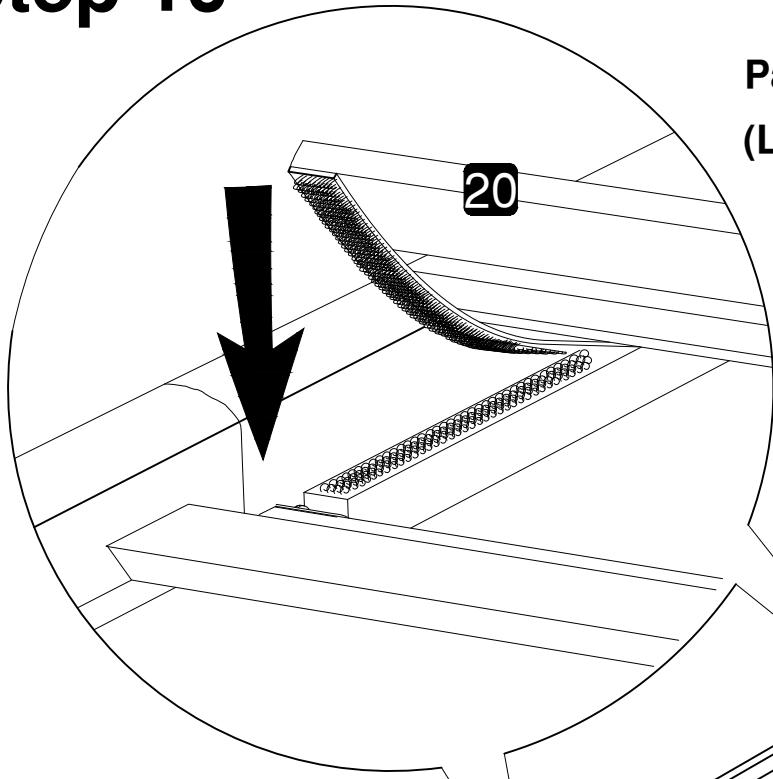

Step 11

