

ASSEMBLY INSTRUCTIONS

**PARTS AND FITTING PACKAGING DETAIL**

**BOX#1**

A. BODY 1PC

B. STAND 1PC

C. WHEEL BRACKET

D. WHEELS 2PCS

E. HANDLE 1PC

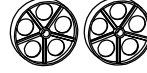
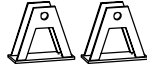
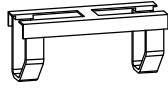
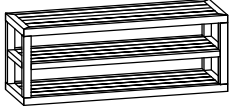

**ASSEMBLED**

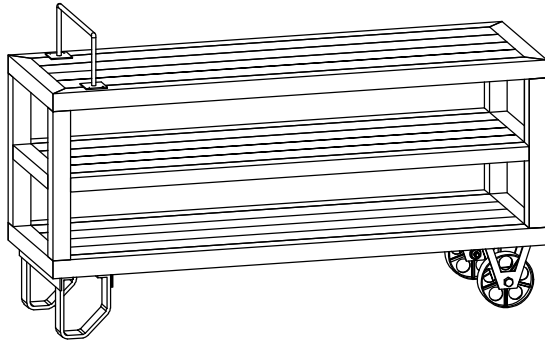

**HARDWARE \* PACKED IN BOX #1**

H1	BOLT M8 X 30mm	16 PCS	H2	WHEEL AXEL Ø25 X Ø80mm	2 PCS
H3	FLAT WASHERS 2 X Ø14 X Ø32mm	2 PCS	H4	NUT Ø14 X Ø6mm	2 PCS
H5	HEX WRENCH 23mm	1 PC	H6	ALLEN KEY M4	1 PCS

**YOUR BOX MAY CONTAIN EXTRA HARDWARE**

**STEP 1**

Following the illustration, attach the Stand (B) to the bottom of the Body (A) with four Bolts (H1). Tighten completely with provided Allen Key (H6). NOTE! Stand can be installed on either side of the Body.

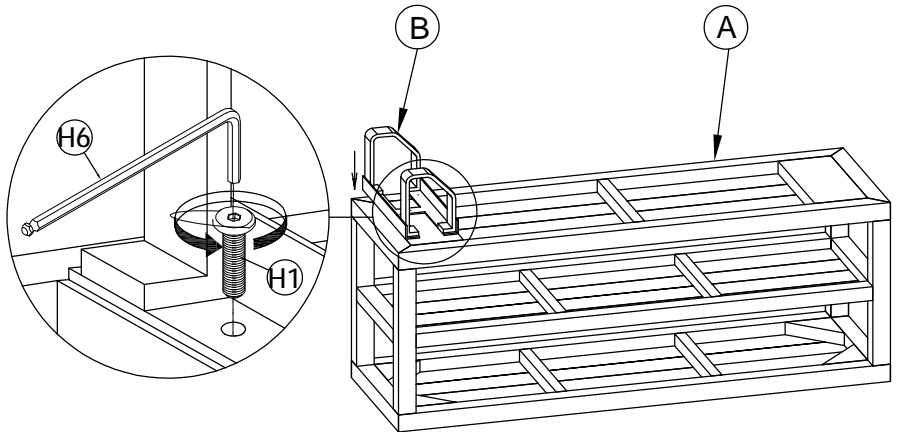

**STEP 2**

Attach one Wheel Bracket (C) to the Body with two Bolts. Tighten completely. Repeat for second Wheel Bracket.

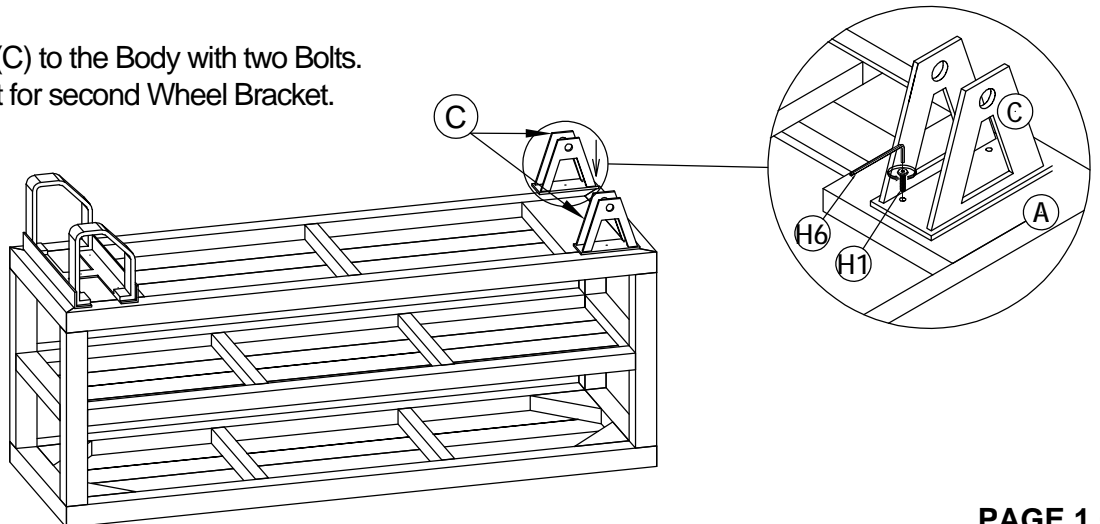

# ASSEMBLY INSTRUCTIONS

## STEP 3

Attach Wheels (D) to Wheel Brackets (C) using Wheel Axels (H2), Washers (H3) and Nuts (H4). Tighten each Nut with Hex Wrench (H5).

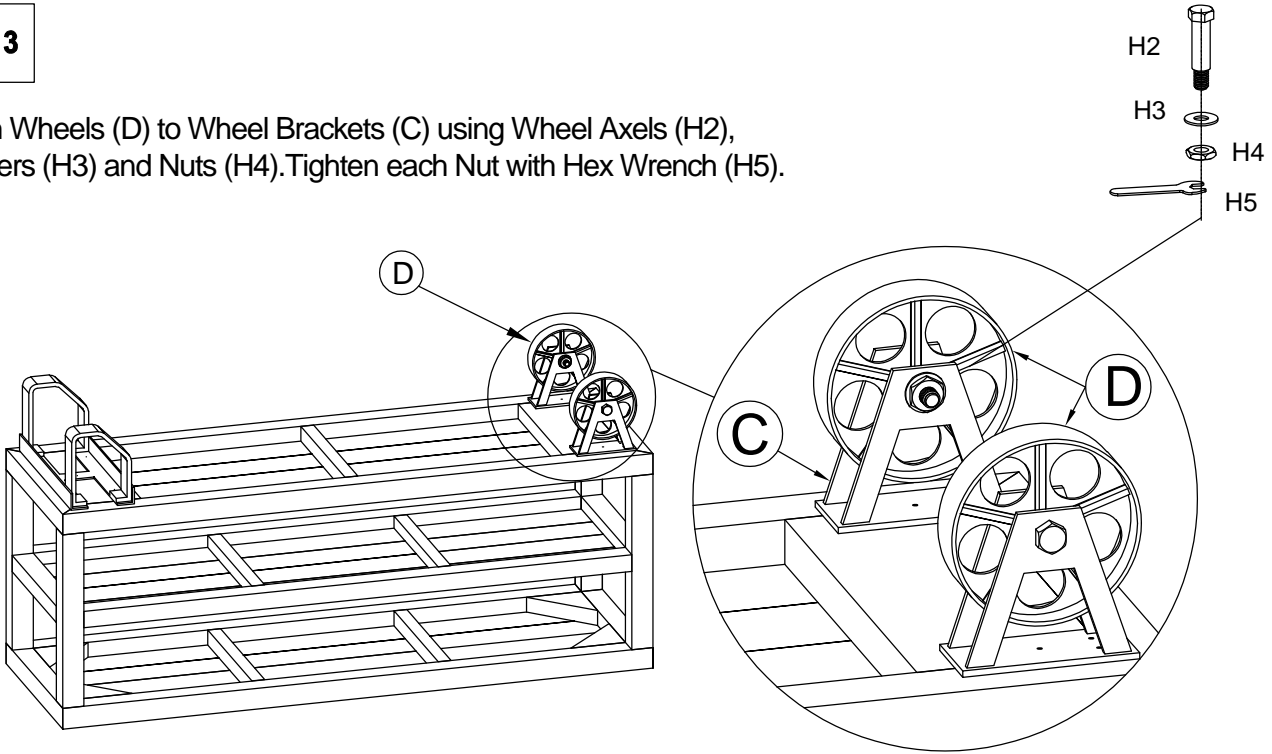

## STEP 4

Flip assembled Body right-side up. Attach Handle (E) to the top of the Body with four Bolts. Tighten completely. NOTE! The Handle should be installed on the same side as the stand.

