

# CHAMELEON WALL MOUNT

## TOOLS REQUIRED

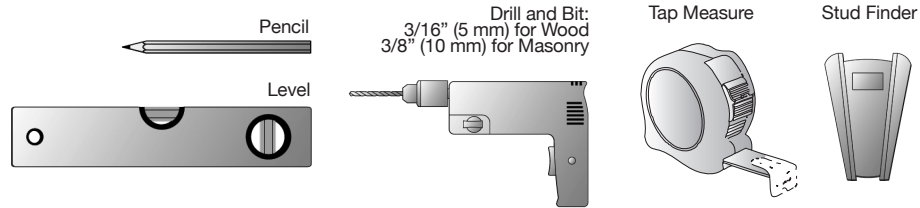

## COMES WITH

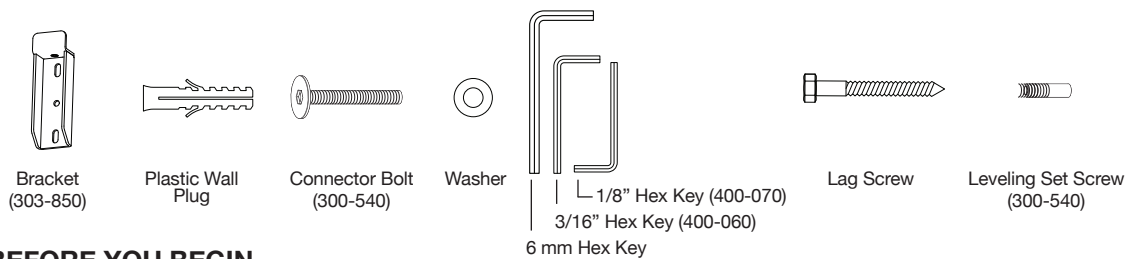

### CAPACITIES (CONTENT)

<b>SINGLE:</b>	100lbs
<b>TWIN:</b>	100lbs
<b>TRIPLE:</b>	200lbs
<b>QUAD:</b>	250lbs

## BEFORE YOU BEGIN

- **This bracket is intended for use with Chameleon 20" Tall Cabinets.**
- **Total weight capacity of each bracket is: 100 lbs. (45kg). (ex 3 brackets provides 300 lbs. (135kg)).**
- Carefully inspect your items for shipping damage or missing parts. If any damage is apparent or you are missing parts contact Salamander Designs Ltd. at 800-535-5659.
- Read ALL assembly instructions before assembly. If you have any questions, please contact your installation contractor or Salamander Designs.
- Use with products heavier than the maximum weight or other than the cabinet indicated may result in instability causing possible injury or damage.
- Mounts must be attached as specified in assembly instructions. Improper installation can result in serious personal injury.

**1. Remove top and feet. Install provided connector bolt in previous foot locations.**

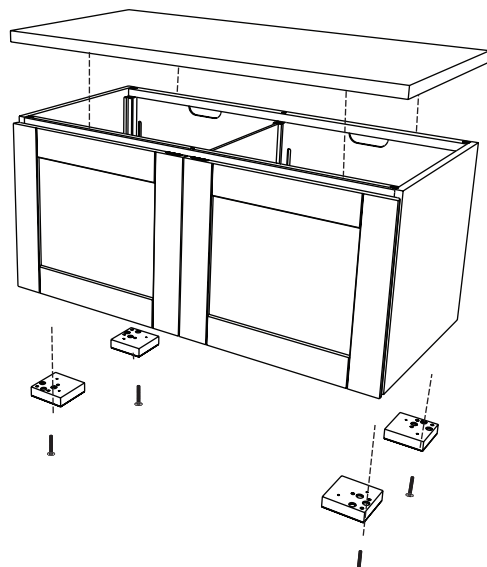

## 2. MARK WALL LOCATION

**A. WOOD CONSTRUCTION** - Using a stud finder, mark the locations of the studs in the area to be covered by the cabinet. It may be necessary to shift the cabinet slightly left or right to avoid the mounting brackets being obstructed by the vertical framework of the cabinet.

Note: It is not important that the brackets are not located in the same relative location in each bay. As long as a bracket is located every 16" on center sufficient capacity will be met.

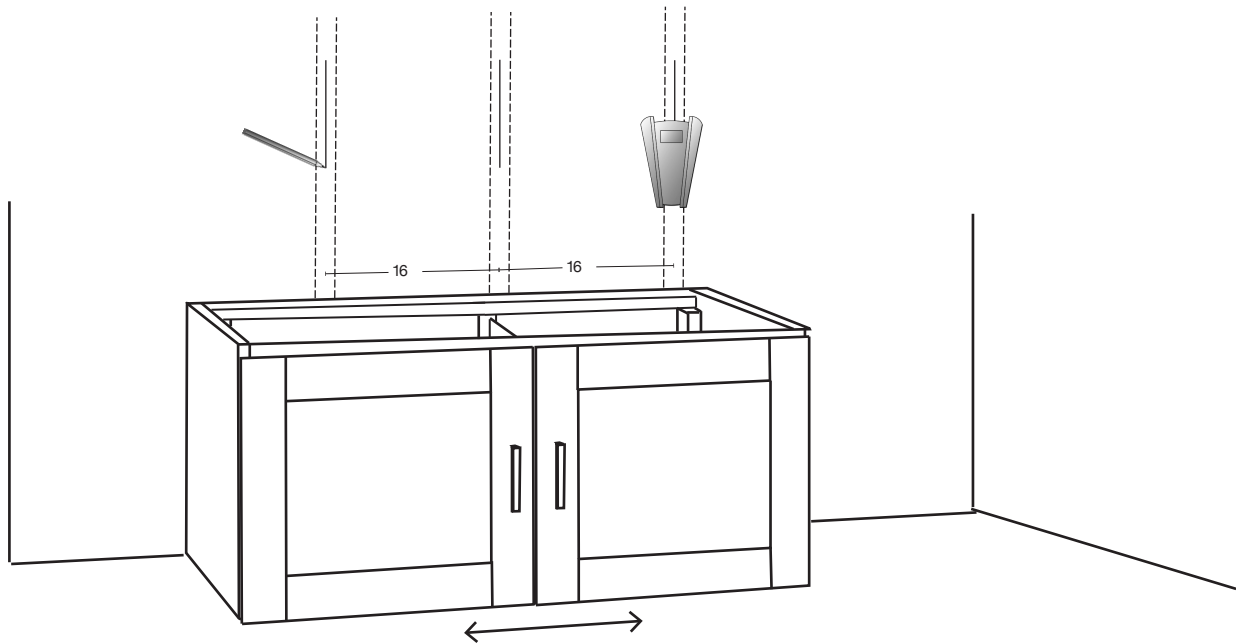

**B. MASONRY CONSTRUCTION** - Mark the wall 2" inward from each side panel and 2" left or right of each divider panel.

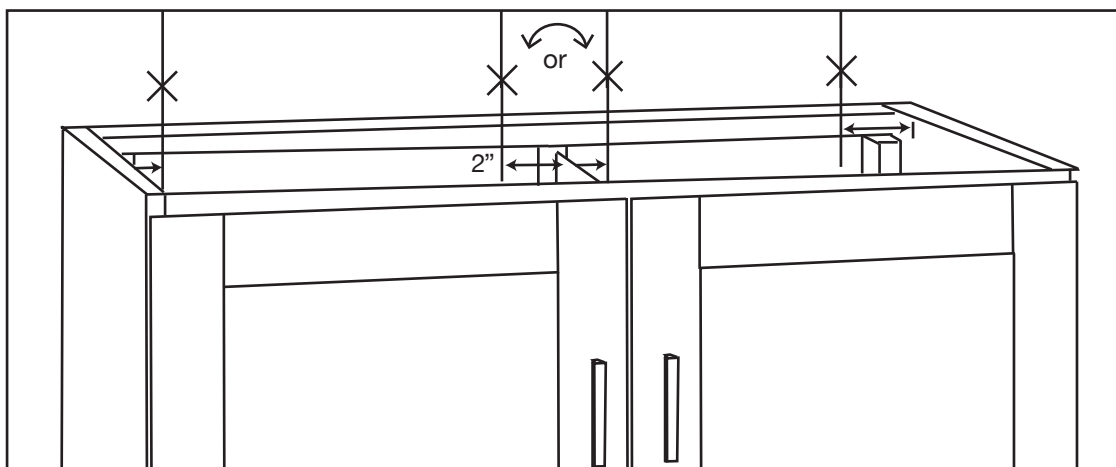

### 3. MARK HEIGHT LOCATION

Move the cabinet from the mounting location. Determine the desired height of the top of the cabinet (28" (711mm) is common). From this height subtract 2-1/4" (57mm) for a glass top cabinet or 2-7/8" (73mm) for a wood top cabinet. This will be the location of the top bracket top hole. Using a level, mark the remaining intersecting locations at the same height. Add a second mark 3-3/8" (86mm) below the top bracket hole location for the second fastener for each bracket.

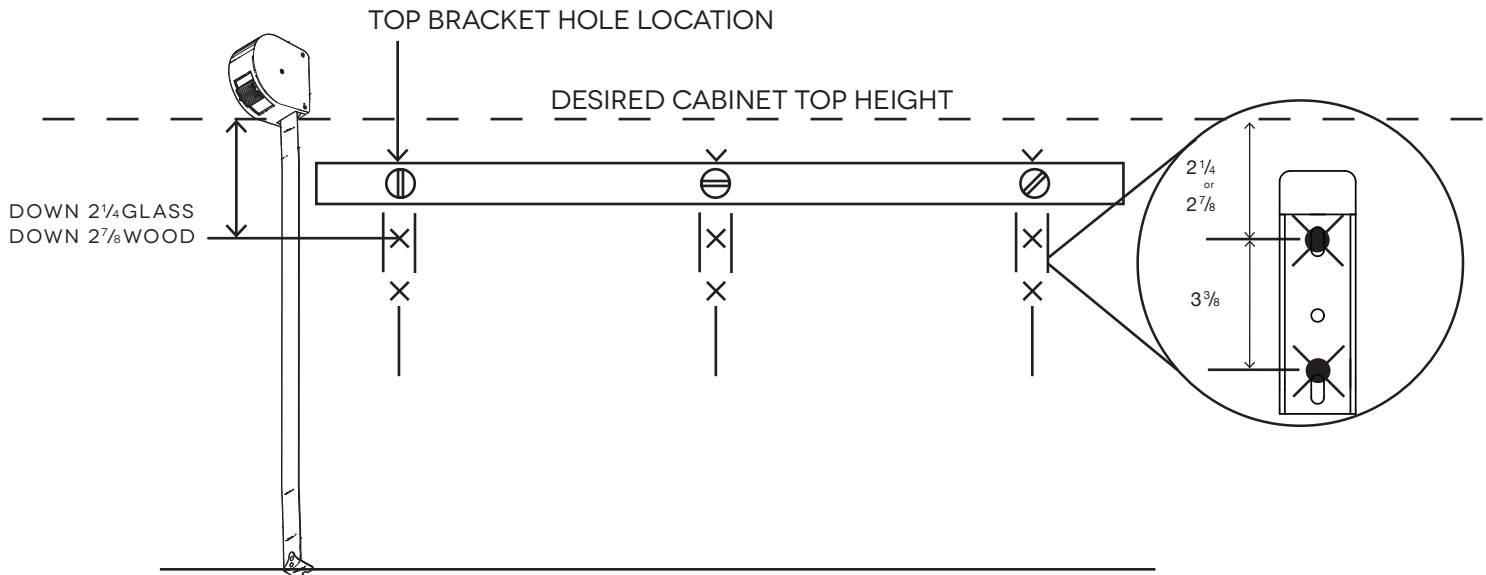

### 4. DRILL WALL HOLES

Predrill mounting holes 2 1/2" (64mm) deep using a 3/16" (5mm) bit for wood construction; 3/8" (10mm) bit for masonry construction.

### 5. INSTALL WALL BRACKETS

A. Install brackets using lag screws (Do not completely tighten). Washers are provided only to be used between wall and brackets to correct for uneven wall surfaces. For masonry insert plastic wall plugs prior to mounting brackets with lag screws.

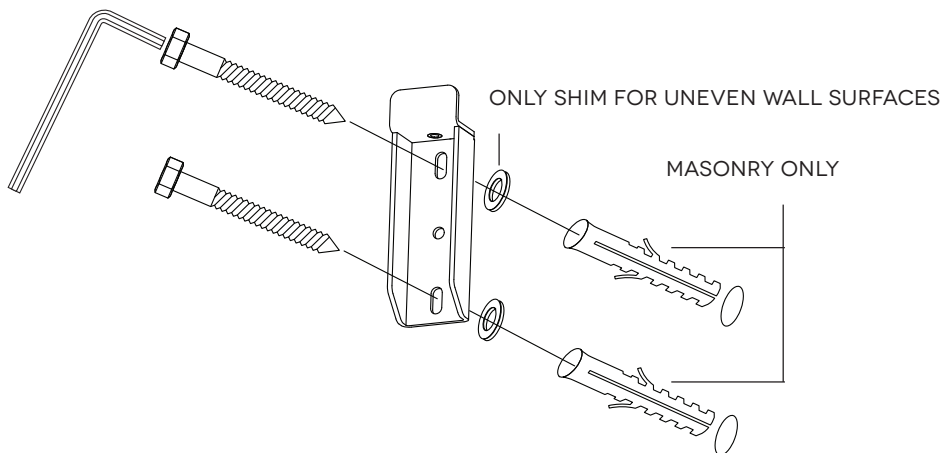

## ADJUST FOR LEVEL

B. Tighten brackets using a level for proper alignment. Install the leveling screws to bracket without screw protruding through top of the bracket.

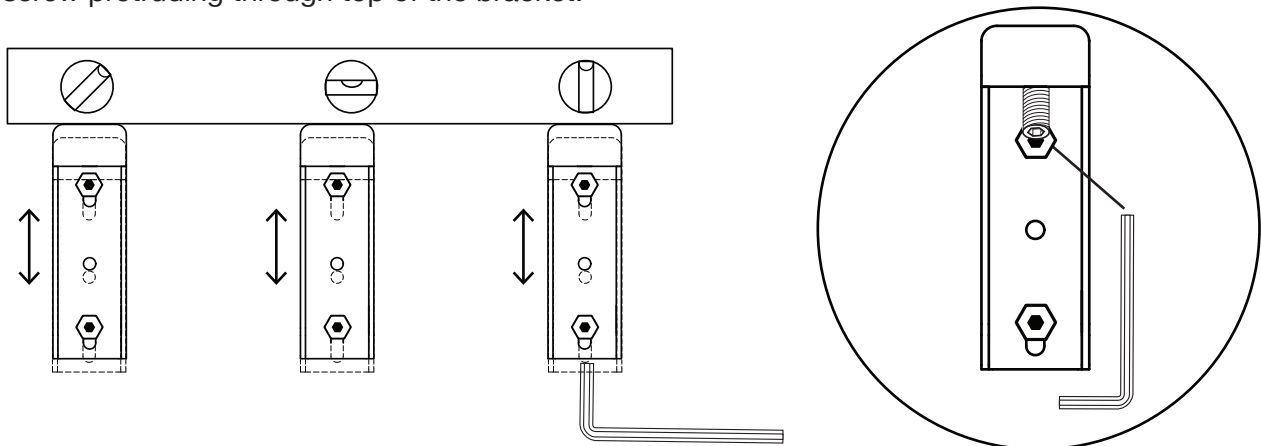

## 7. HANG CABINET

A. Using two people, lift the cabinet placing the rear upper framing member entirely into the bracket "hook".

### FINE TUNE LEVELING

A. Adjust side to side to position as desired.

B. Using a level, adjust the leveling screws if necessary. Be sure that all leveling screws are in contact with the cabinet frame.

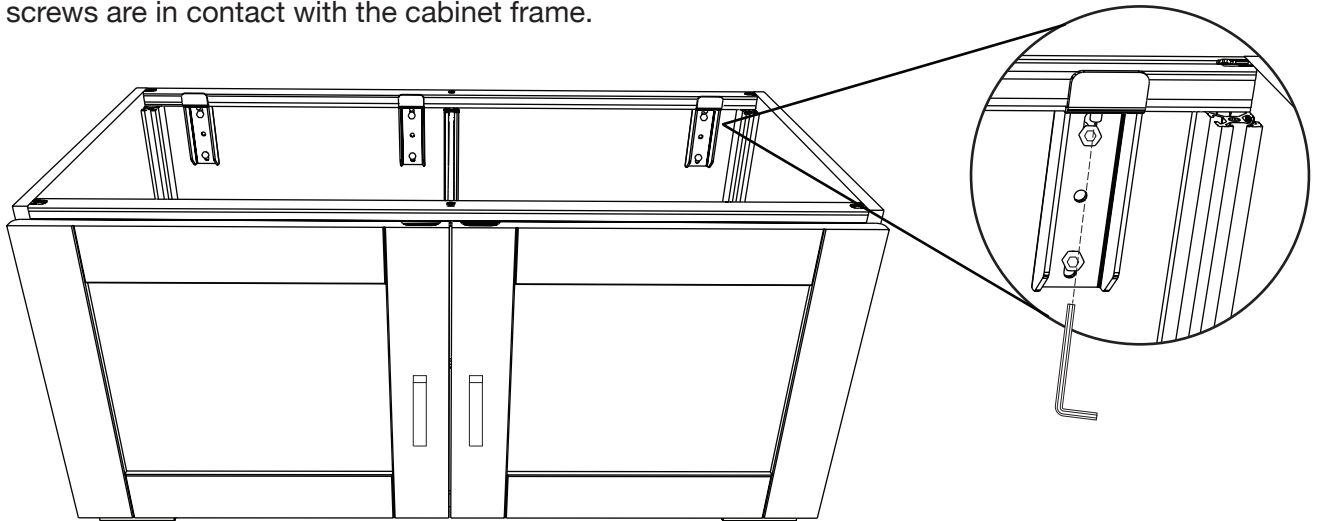

## 8. INSTALL A/V COMPONENTS & SECURE TOP

With the top still removed, configure shelving and install your a/v components.

When complete, install cabinet top. For wood tops, use only the front fastening locations.

### LIMITED WARRANTY

For five full years Salamander Designs Ltd. will repair or replace, at our option, any product defective in materials or craftsmanship. Salamander Designs Ltd. will not be responsible for any damage to or destruction of other equipment consequential to our equipment failure. Defective product must be given Return Authorization and is to be returned to the factory prepaid, in the original carton and packing material. Any damage incurred in a shipment not in original packaging shall be the responsibility of the owner. Warranty repairs will be returned prepaid, via UPS within the continental U.S.A. only.