

ASSEMBLY INSTRUCTIONS DINING TABLE

ASSEMBLY
REQUIREMENTS

2-PERSON
ASSEMBLY

45 MINUTES
ASSEMBLY TIME

Thank you for purchasing our product!

Please refer and use this assembly instruction to assemble the product. Contact our customer service department in case there are any missing or damage parts or hardware. Replacement parts are normally shipped within 2 or 3 days

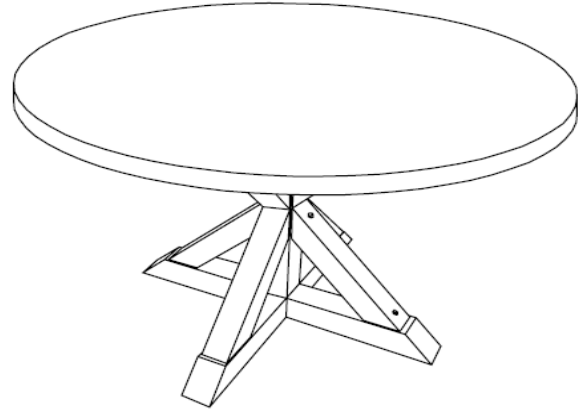

We appreciate your business!

ASSEMBLY PREPARATION

1. Remove all packing materials, staples and packing straps from the carton.
2. Refer to Parts List and Hardware List. Ensure all the parts, hardware and quantities are correct before assembly. Contact customer service for missing part.
3. Place all wooden parts on a clean, flat and soft surface (e.g. carpet or rug) to prevent parts from getting scratched.

SAFETY PRECAUTION

1. KEEP ALL HARDWARE PARTS OUT OF REACH OF CHILDREN.
2. DISPOSE PLASTIC PACKAGING MATERIAL IMMEDIATELY TO AVOID ANY RISK OF SUFFOCATION TO CHILDREN AND ANIMALS.

TIPS FOR ASSEMBLY

1. Allow ample room for assembly and in close proximity to where product will be placed.
2. Assemble the product on a surface that does not scratch or damage the exterior gloss and finish of the furniture.
3. Identify all of the parts, hardware and quantities required for each step.
4. During assembly, do not over-tighten any fittings as this may cause damage.
5. DO NOT USE POWER TOOLS TO ASSEMBLE THIS PRODUCT.
6. Always place the product on a flat, level surface.
7. Do not sit or stand on the partially assembled product; only use the product for which it is intended.

CARE AND MAINTANANCE

- Use a slightly damp cloth to clean the product. Do not use bleach or abrasive cleaning material.
- Check all the fittings periodically and re-tighten as necessary. Do not use the product if any of the parts is damaged or broken.
- Never allow any kind of liquid to remain on your furniture. Absorption can cause wood to warp or delaminate.
- Do not place hot items (e.g. hot drinks) directly onto the wood surface.
- Do not drag and/or pull the furniture.







This product is for indoor and household use only – not for commercial use.

ASSEMBLY INSTRUCTIONS DINING TABLE

PART LIST (FOR 1 TABLE)

NO.	COMPONENT	QTY.
P1	TABLE TOP	1
P2	MAIN TABLE LEG FRAME	1
P3	BASE BAR	1
P4	STRETCHER	4
P5	MOUNTING BAR	1

HARDWARE LIST (FOR 1 TABLE)

NO.	DESCRIPTION	QTY.	EXTRA
H1	JCBC SCREW M6X45 	12	1
H2	SPRING WASHER 	4	2
H3	FLAT WASHER 	4	2
H4	ADJUSTABLE LEG GLIDE 	4	1
H5	ALLEN KEY 	1	
H6	WOOD DOWEL M8X30 	8	1

* Extra Hardware For Spare Use

STEP 1

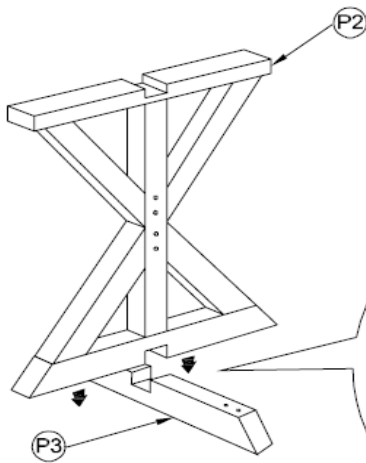

STEP 2

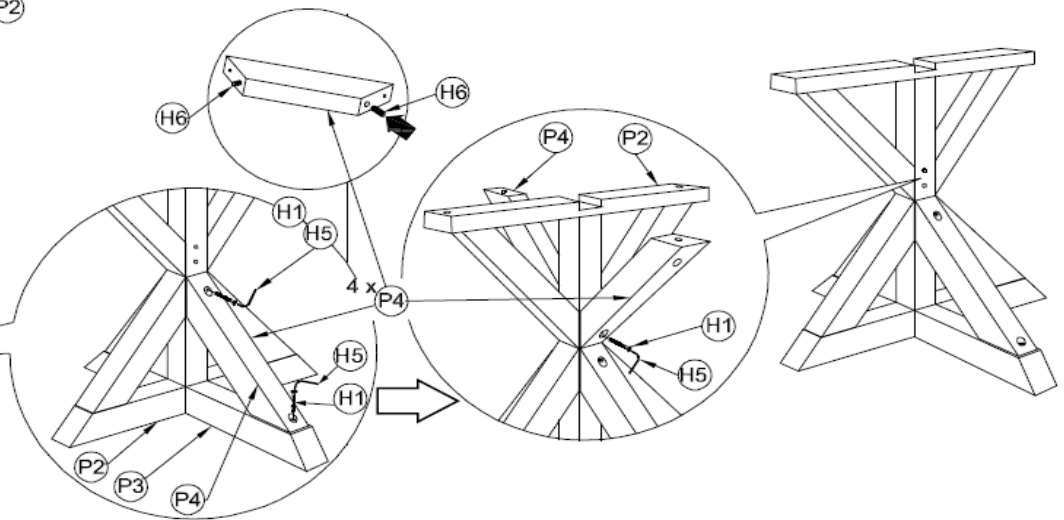

STEP 1A: Assemble Leg Section of Table

- Lay Base Bar (P3) with the cross edge half-lap facing up as shown.
- Position the Main Table Leg Frame (P2) perpendicular to (P3) to mate the cross edge half lap on each part.

STEP 1B: Install Stretcher to Leg Section of Table:

- Insert Wood Dowel (H6) into the designated holes (non-through holes) on each Stretcher (P4) - 4 pieces
- Attach (P4) to (P3) and (P2) via (H6).
- Fasten (P4) to (P3) and (P2) with Screw (H1).
Use Allen Key (H5) to drive (H1).
- Use the above procedures c) through e) to install another Stretcher to (P3) and (P2) to complete the leg section of the table.

Install Stretcher to Upper Section of Table:

- Attach Stretcher (P4) to (P2) via wood dowel on (P4).
- Fasten (P4) to (P2) with Screw (H1).
Use Allen Key (H5) to drive (H1). Do not tighten (H1) completely at this time.
- Use the above procedures to install the last Stretcher to (P2).

ASSEMBLY INSTRUCTIONS DINING TABLE

STEP 3

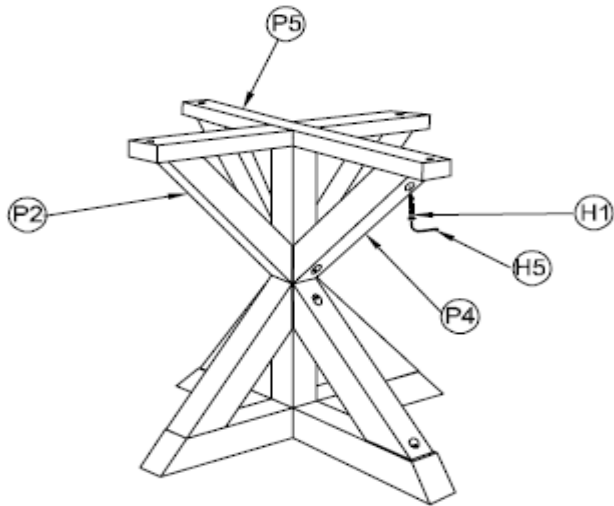

- Place Mounting Bar (P5) perpendicular to (P2) to mate the half lap on each part and at the same time attach (P5) to both Stretcher (P4) via wood dowel on (P4).
- Fasten (P5) to (P4) with Screw (H1). Use Allen Key (H5) to drive (H1). Tighten all of the Screws (H1) on the Upper Section of the Table completely at this time.

STEP 4

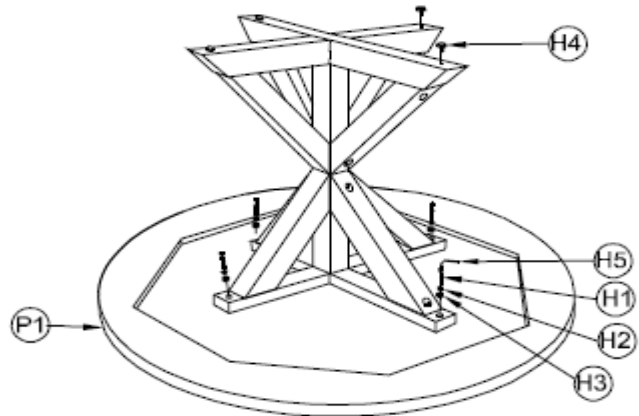

- With assistance, lay Table Top (P1) bottom-side up flat on a material that does not scratch or damage the part.
- Position assembly from STEP 3 with Mounting Bar (P5) facing down as shown.
- Align the screw holes on (P5) and (P2) to the screw holes on Table Top (P1).
- Use Screw (H1) fitted with Spring Washer (H2) and Flat Washer (H3) to fasten (P1) to (P2 and P5). Use Allen Key (H5) to drive (H1). Do not tighten (H1) completely until all of the screws are in place.
- Insert Adjustable Leg Glide (H4) to the base bar holes, and use hand to screw in (H4). Do not over tighten.

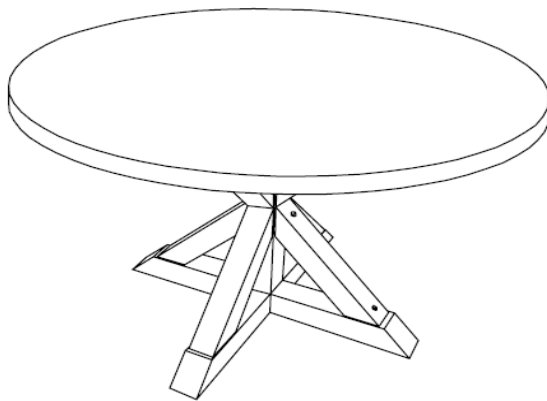

Set the table right-side up.

The assembly of the table is complete.