

# Full Bed

## Assembly Instructions

WI-0820

### 1 Assembled View

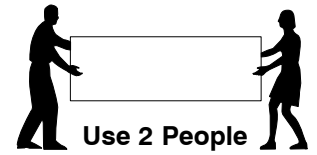
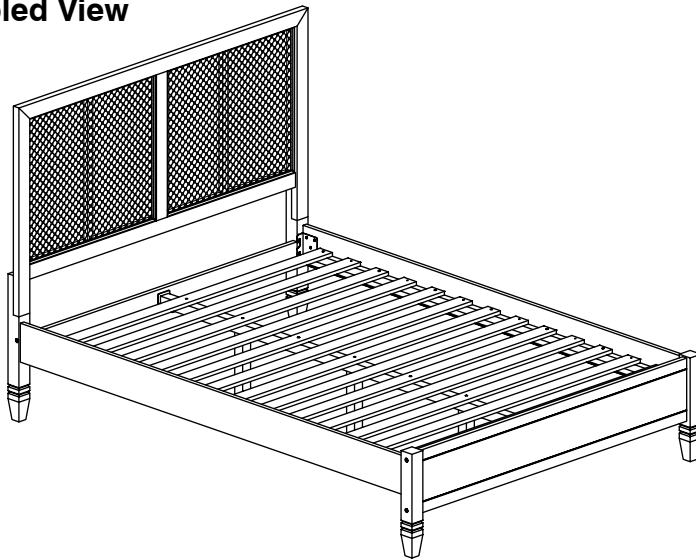

**Note:** Do not assemble using power tools. This can cause the bolts to be overtightened

### 2 Parts List

#### Parts in Box A:

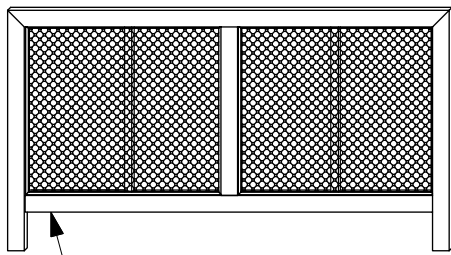

**A** Headboard Panel x 1

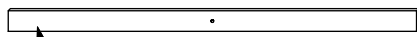

**B** Headboard Support x 1

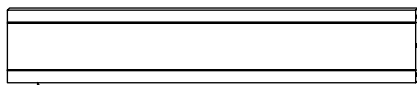

**C** Footboard Panel x 1

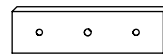

**D** Footboard Support Bar x 1



**E** Footboard Post (Left hand) x 1



**F** Footboard Post (Right hand) x 1

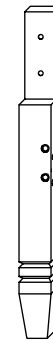

**G** Headboard Post (Left hand) x 1

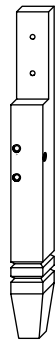

**H** Headboard Post (Right hand) x 1

#### Parts in Box B:

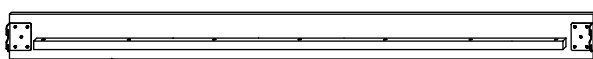

**J** Side Rail x 2



**K** Long Support x 1



**L** Support Leg x 3

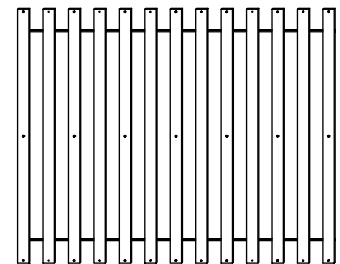

**M** Set of Bed Slats x 1

# Full Bed

## Assembly Instructions

WI-0820

### 3 Hardware List

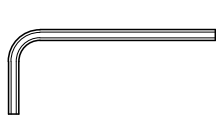

1 M4 Allen Key  
x 1

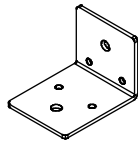

2 Center Rail  
Bracket x 2

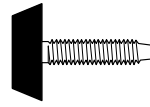

3 Adjustable  
Foot x 3



4 Barrel Nut  
x 9

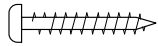

5 Wood Screw  
(M4 x 32mm)  
x 12



6 Wood Dowel  
(10 x 40mm)  
x 4



7 Spring  
Washer  
x 12



8 Flat  
Washer  
x 12



9 M6 x  
15mm JCB  
x 4

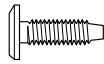

10 M6 x  
20mm JCB  
x 8



11 M6 x  
30mm JCB  
x 2



12 M6 x  
40mm JCB  
x 22



13 M6 x 90mm JCB  
x 6



14 M6 x 100mm JCB  
x 3

### 4 Fix the Adjustable foot to the bottom of the Support Leg (L).

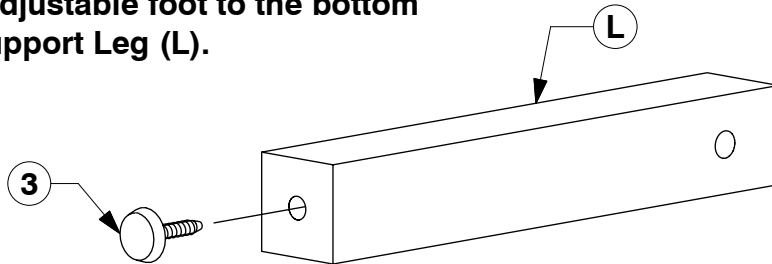

x3

### 5 Fit the Center Rail Bracket to the Headboard Support (B).

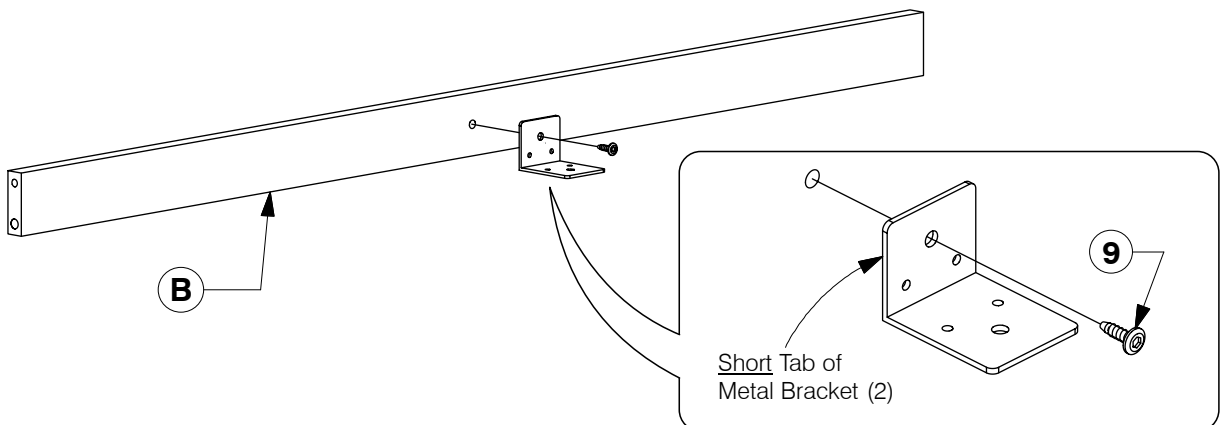

# Full Bed

Assembly Instructions

WI-0820

## 6 Fit the Center Rail Bracket to the Footboard Support Bar (D).

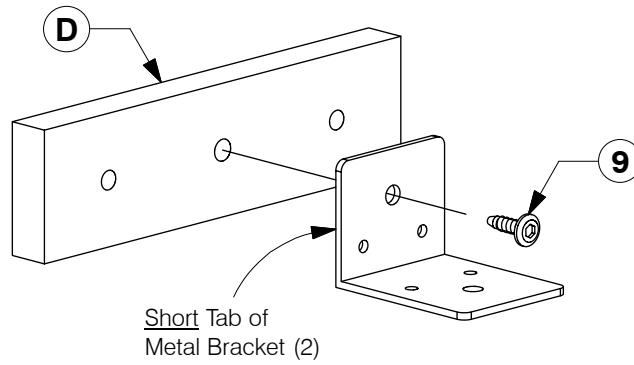

## 7 Fit the Footboard Support Bar (D) to the Footboard Panel (C).

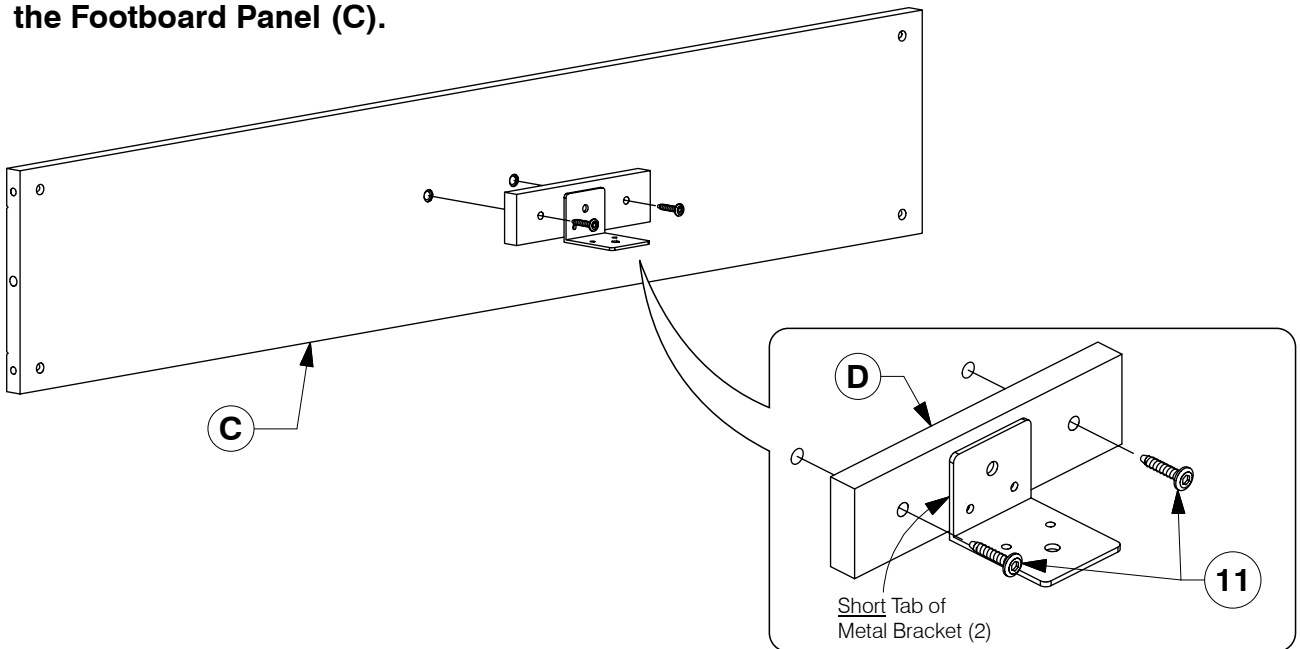

## 8 Assemble the Footboard Post (E & F) to the Footboard Panel (C).

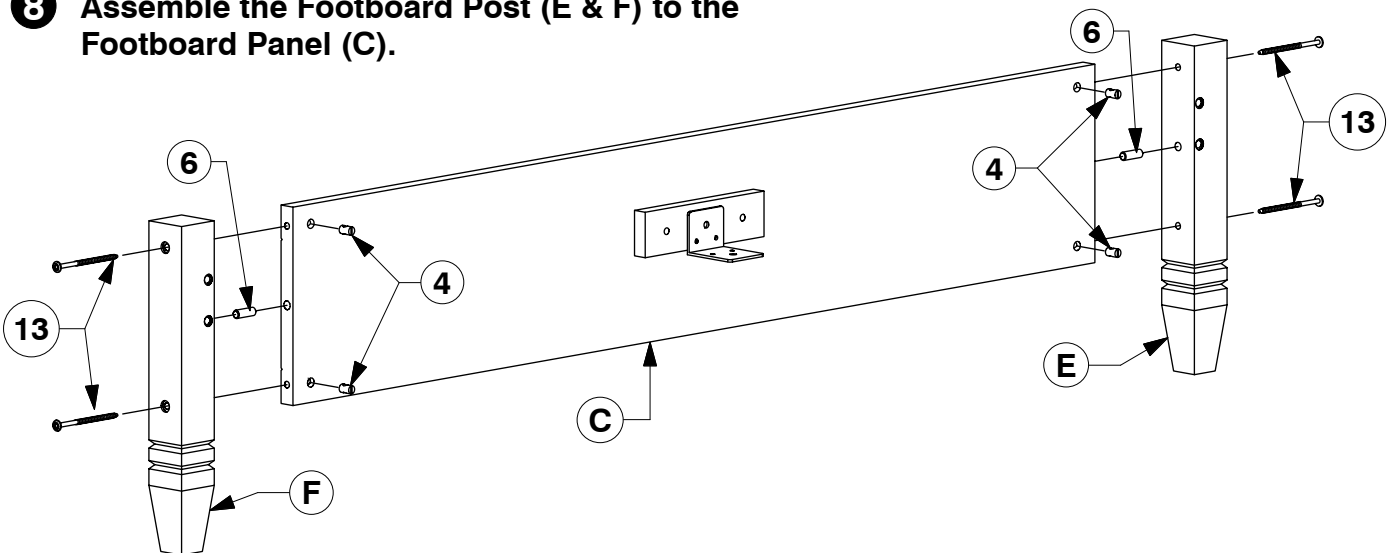

# Full Bed

## Assembly Instructions

WI-0820

- 9** Assemble the Headboard Support (B) to the Headboard Post (G & H).

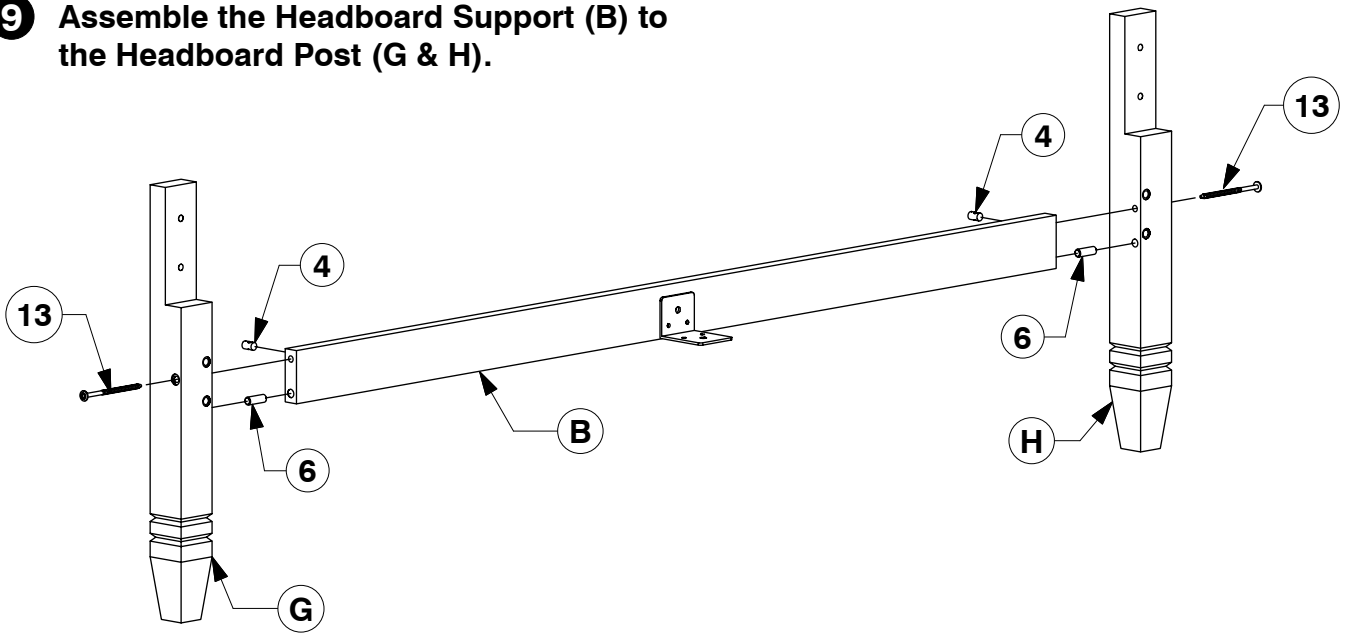

- 10** Assemble the Headboard Panel (A) to the assembled Headboard Post (G & H) & Headboard Support (B).

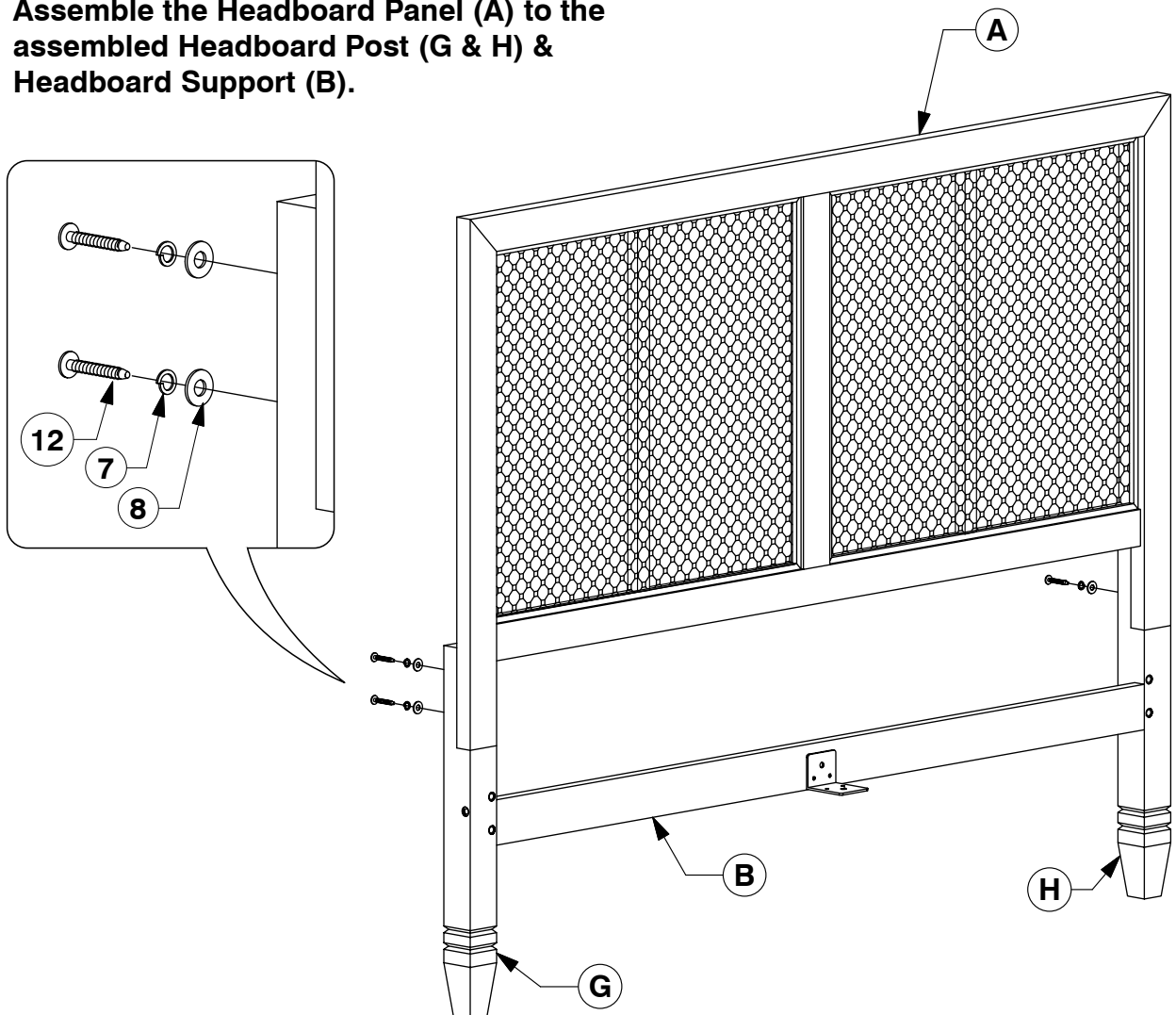

# Full Bed

## Assembly Instructions

WI-0820

- 11** Assemble the Side Rail (J) to the Headboard & Footboard Panel (A & C).

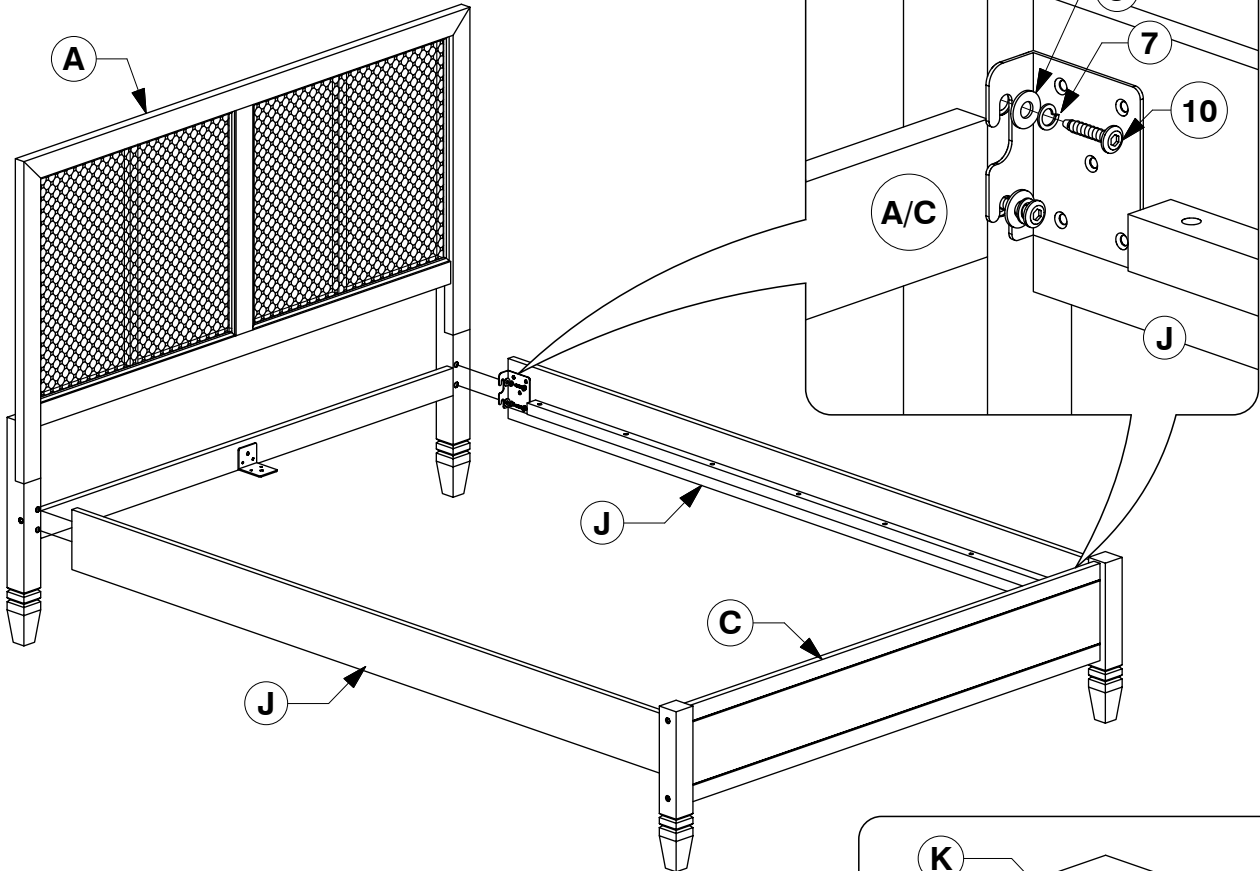

- 12** Bolt the Long Support (K) to the Center Rail Brackets on the Headboard Support (B) and Footboard Panel (C).

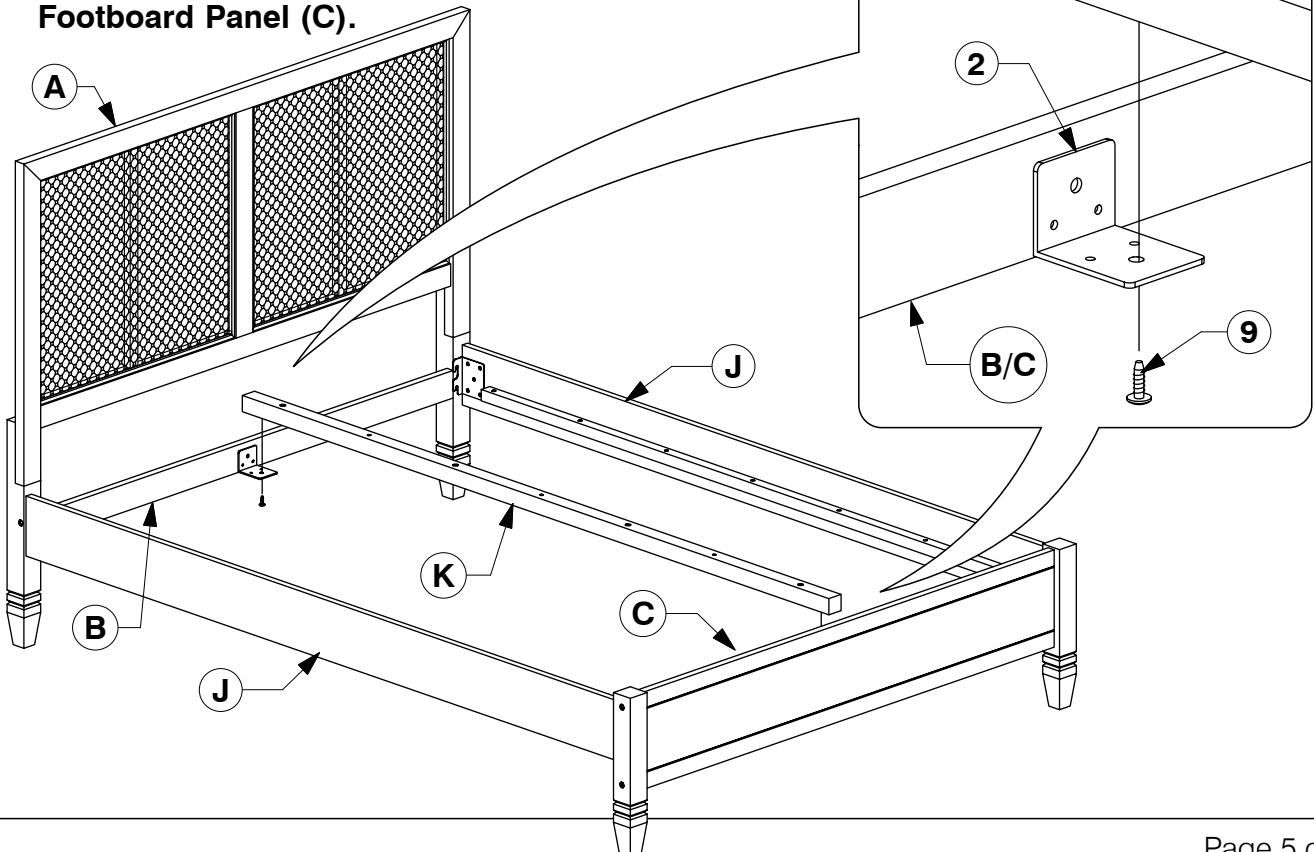

# Full Bed

## Assembly Instructions

WI-0820

- 13** Fit the first 3 Slats and assemble the Support Leg (L) to the Bed Slat (M). Bolt & screw the Bed Slats (M) to the Side Rail (J) & Long Support (K).

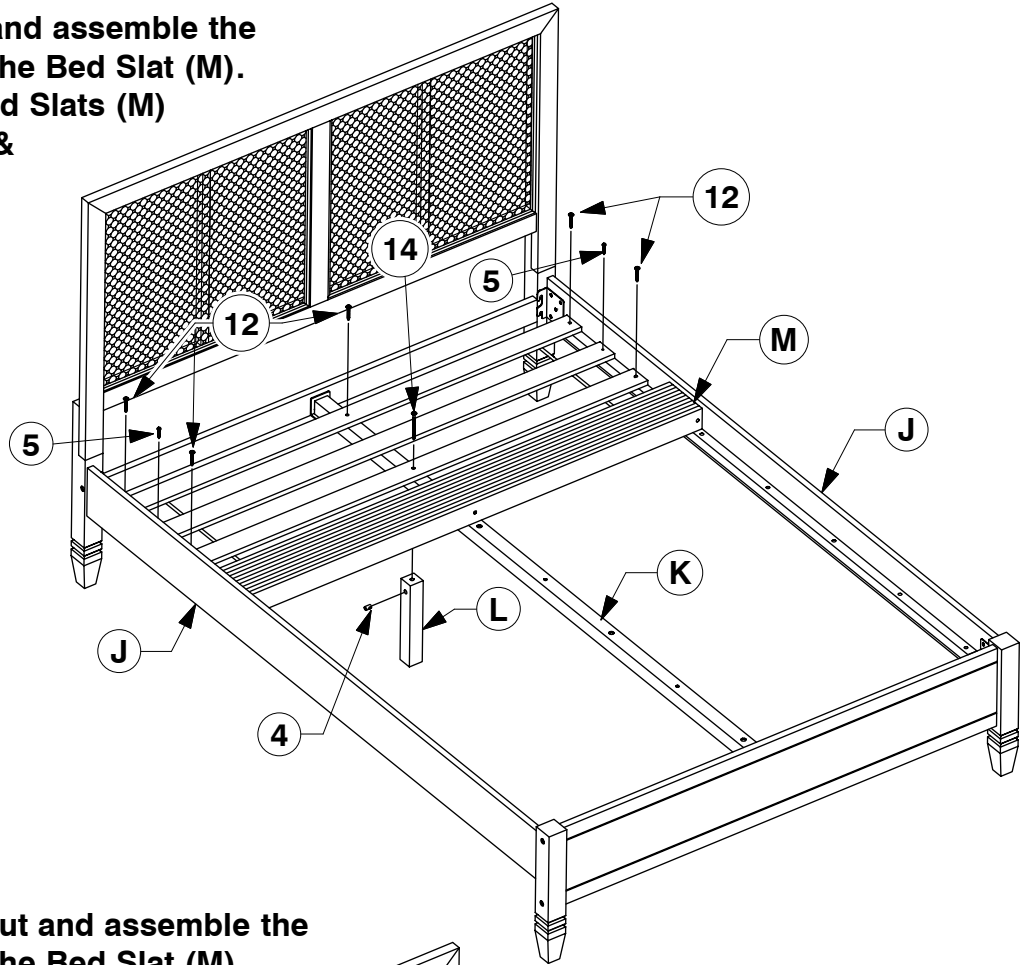

- 14** Fit the other Slats out and assemble the Support Leg (L) to the Bed Slat (M). Bolt & screw the Bed Slats (M) to the Side Rail (J) & Long Support (K).

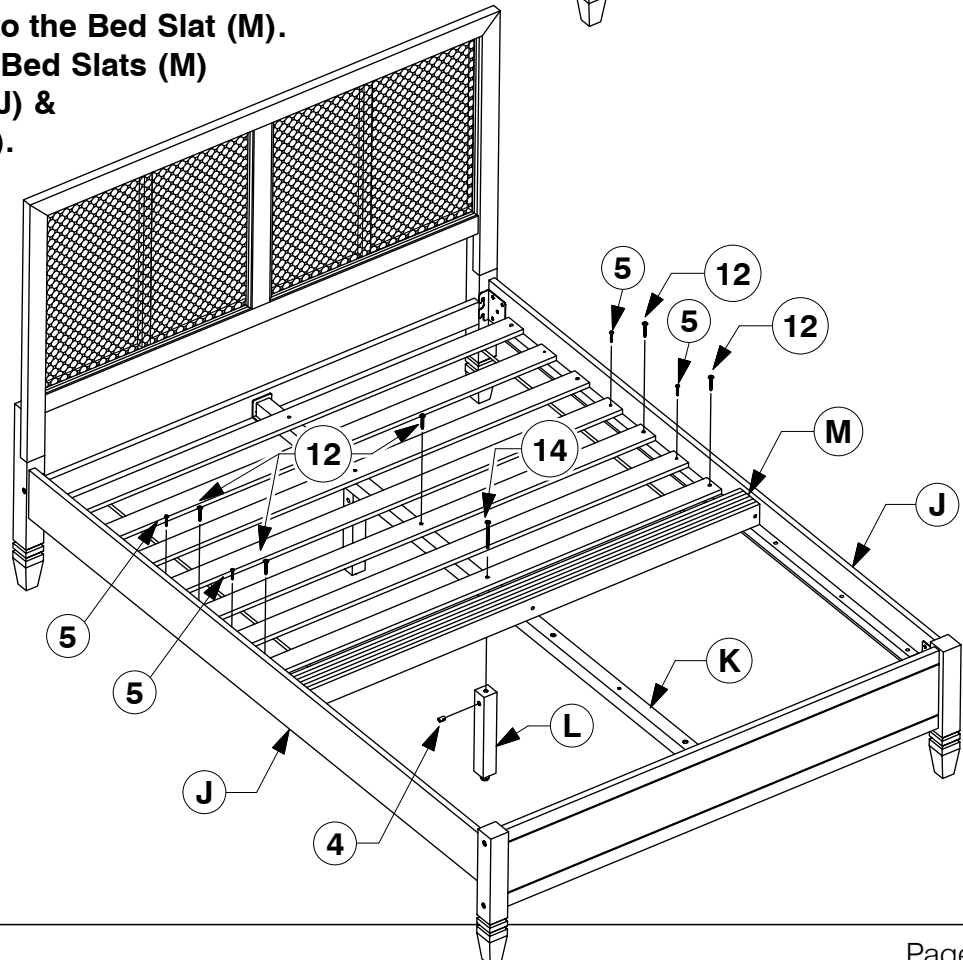

# Full Bed

## Assembly Instructions

WI-0820

- 15** Fit the other Slats out and assemble the Support Leg (L) to the Bed Slat (M). Bolt & screw the Bed Slats (M) to the Side Rail (J) & Long Support (K).

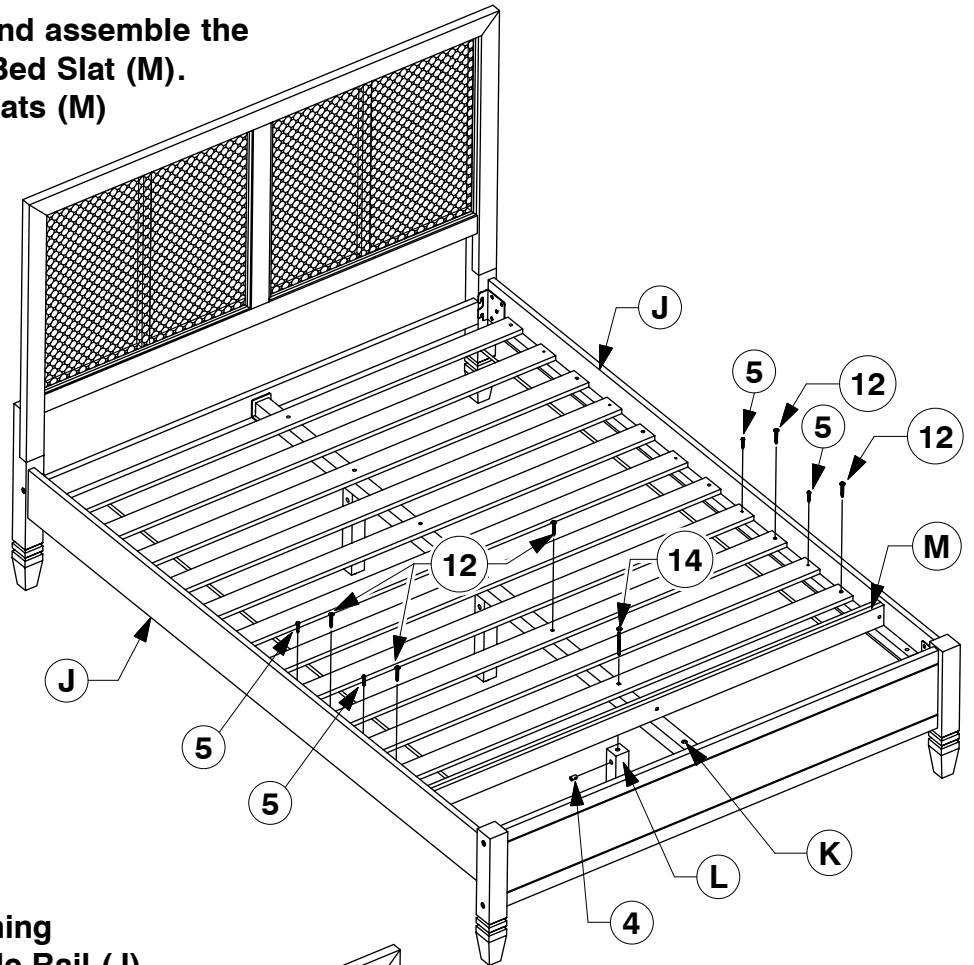

- 16** Bolt & screw the remaining Bed Slats (M) to the Side Rail (J).

