

Any questions please contact us

3h

APPROXIMATE ASSEMBLY TIME

2 PERSONS OF ASSEMBLY

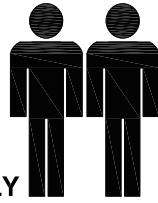

FLOOR AREA
1.83M

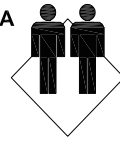

REQUIRED ASSEMBLY SPACE

REQUIRED ASSEMBLY TOOLS

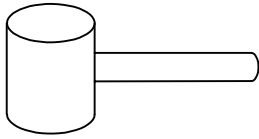

SOFT RUBBER HAMMER

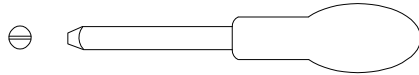

SLOTTED SCREWDRIVER



POZI SCREWDRIVER

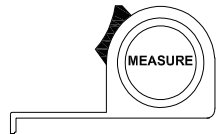

MEASURING TAPE

ASSEMBLED DIMENSIONS

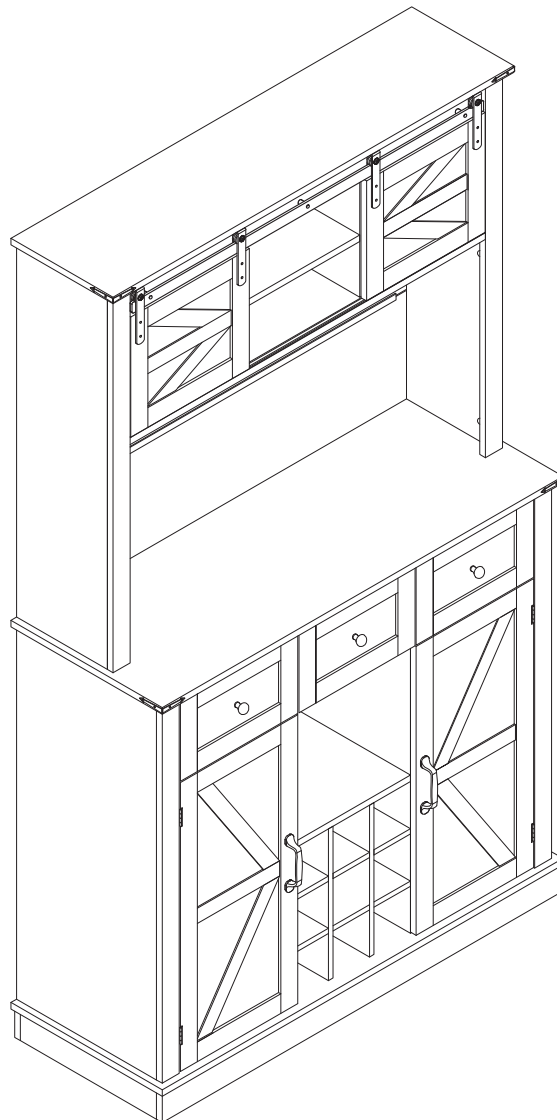

Before You Start

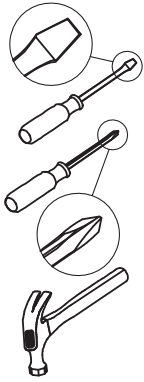

- ✓ Read through each step carefully and follow the proper order
- ✓ Separate and count all your parts and hardware
- ✓ Give yourself enough room for the assembly process
- ✓ Have the following tools: Flat Head Screwdriver, #2 Phillips Head Screwdriver and Hammer
- ✓ Caution: If using a power drill or power screwdriver for screwing, please be aware of to slow down and stop when screw is tight. Failure to do so may result in stripping the screw.

Helpful Hints



PEOPLE NEEDED FOR ASSEMBLY: 1-2



- Open your item in the area you plan to keep it to avoid excessive heavy lifting.
- Identify, sort and count the parts before attempting assembly.
- Compression dowels are lightly tapped in with a hammer.
- Slides are labeled with an **R** (right) and **L** (left) for proper placement.
- Make sure to always face the point on the top of the Cam Lock towards the outer edge.
- Use all the nails provided for the back panel and spread them out equally.
- Back panel must be used to make sure your unit is sturdy.
- Do NOT use harsh chemicals or abrasive cleaners on this item.
- Never push, pull, or drag your furniture.

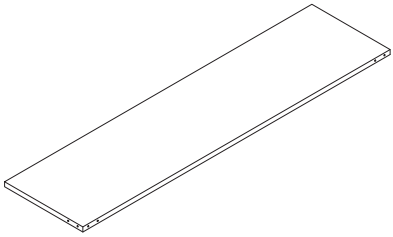
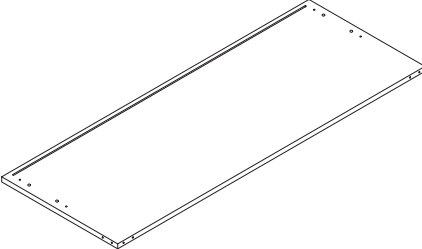
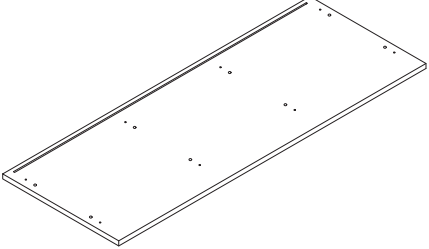
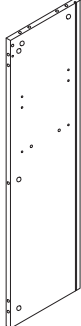
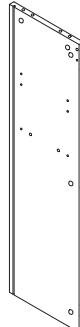
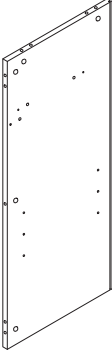
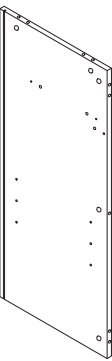
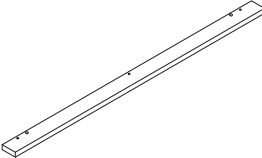
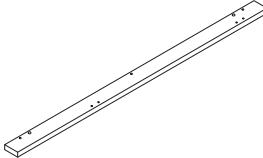
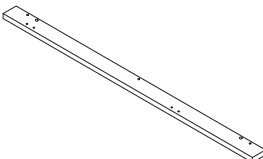
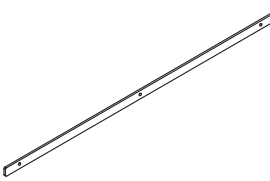
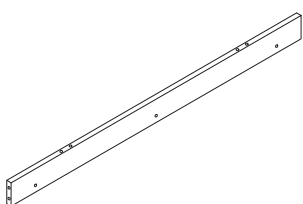

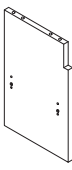
Part List

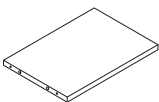
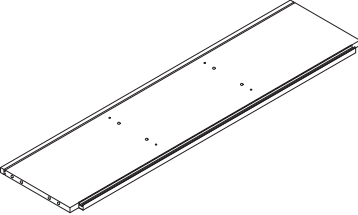
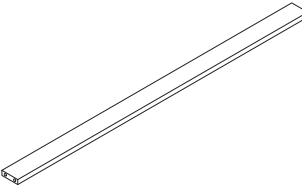
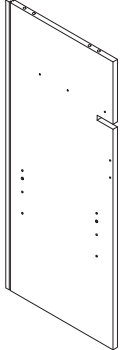
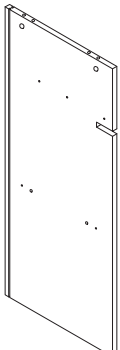
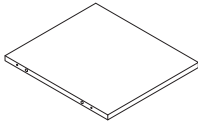
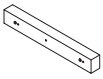
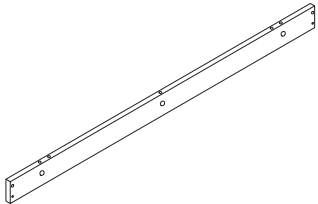
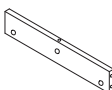
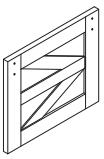
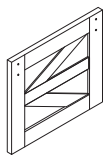
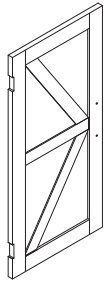
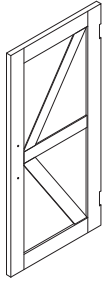
<p>①</p>  <p>1PC</p>	<p>②</p>  <p>1PC</p>	<p>③</p>  <p>1PC</p>
<p>④</p>  <p>1PC</p>	<p>⑤</p>  <p>1PC</p>	<p>⑥</p>  <p>1PC</p>
<p>⑦</p>  <p>1PC</p>	<p>⑧</p>  <p>2PCS</p>	<p>⑨</p>  <p>1PC</p>
<p>⑩</p>  <p>1PC</p>	<p>⑪</p>  <p>1PC</p>	<p>⑫</p>  <p>1PC</p>

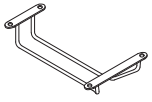
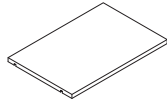
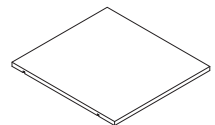
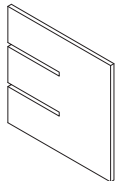
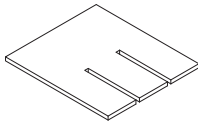
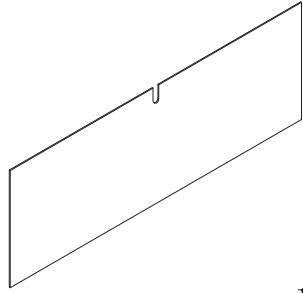
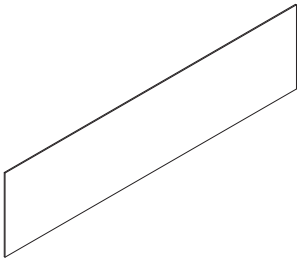
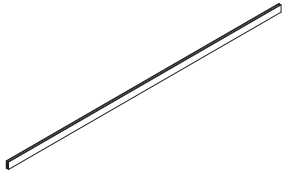
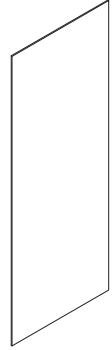
<p>⑬</p>  <p>1PC</p>	<p>⑭</p>  <p>1PC</p>	<p>⑮</p>  <p>1PC</p>
<p>⑯</p>  <p>1PC</p>	<p>⑰</p>  <p>1PC</p>	<p>⑱</p>  <p>1PC</p>
<p>⑲</p>  <p>1PC</p>	<p>⑳</p>  <p>1PC</p>	<p>㉑</p>  <p>2PCS</p>
<p>㉒</p>  <p>1PC</p>	<p>㉓</p>  <p>2PCS</p>	<p>㉔</p>  <p>1PC</p>
<p>㉕</p>  <p>1PC</p>	<p>㉖</p>  <p>1PC</p>	<p>㉗</p>  <p>1PC</p>

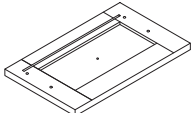
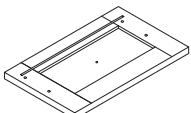
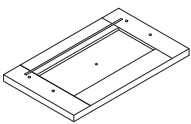
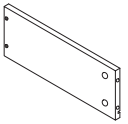
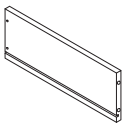
<p>②⑧</p>  <p>4PCS</p>	<p>②⑨</p>  <p>2PCS</p>	<p>③⑩</p>  <p>2PCS</p>
<p>③①</p>  <p>2PCS</p>	<p>③②</p>  <p>2PCS</p>	<p>③③</p>  <p>1PC</p>
<p>③④</p>  <p>2PCS</p>	<p>③⑤</p>  <p>1PC</p>	<p>③⑥</p>  <p>2PCS</p>
<p>③⑦</p>  <p>1PC</p>	<p>③⑧</p>  <p>1PC</p>	<p>③⑨</p>  <p>1PC</p>
<p>④⑩</p>  <p>1PC</p>	<p>④①</p>  <p>3PCS</p>	<p>④②</p>  <p>3PCS</p>

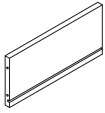
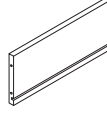
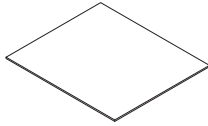
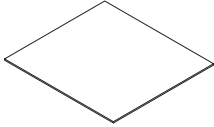



<p>④3</p>  <p>2PCS</p>	<p>④4</p>  <p>1PC</p>	<p>④5</p>  <p>2PCS</p>
<p>④6</p>  <p>1PC</p>		

Accessory List

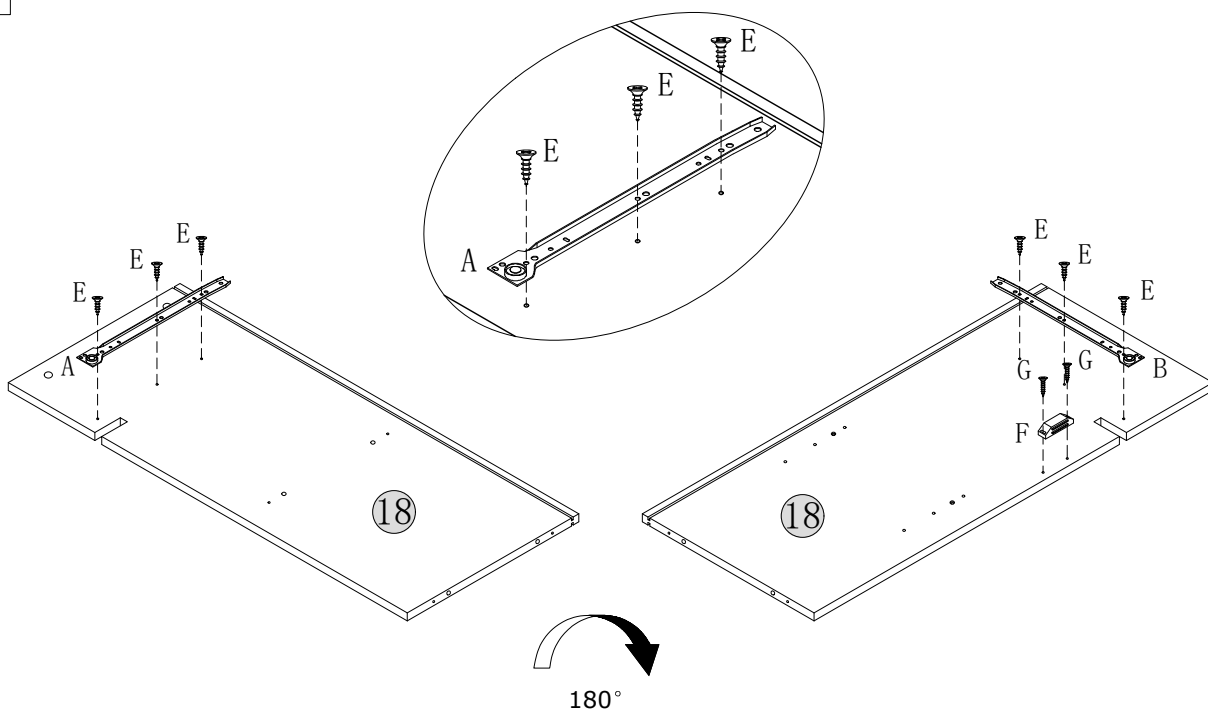
A×3  L 300mm	B×3  L 300mm	C×3  L 300mm	D×3  L 300mm
E×54  φ3×12mm	F×2 	G×4  φ3×14mm	H×70  φ8×30mm
I×28  φ4×35mm	J×4 	K×62  φ6×35mm	L×62  φ15×10mm
M×26  φ4×14mm	N×4 	O×16  φ3×12mm	P×1 
Q×3 	R×3  φ6×25mm	S×16 	T×4 
U×4 	V×2 	W×2 	X×4  φ4×18mm
Y×3 	Z×3  φ4×8mm	a×1 	b×1  φ4×40mm
c×12  φ4×30mm			





1

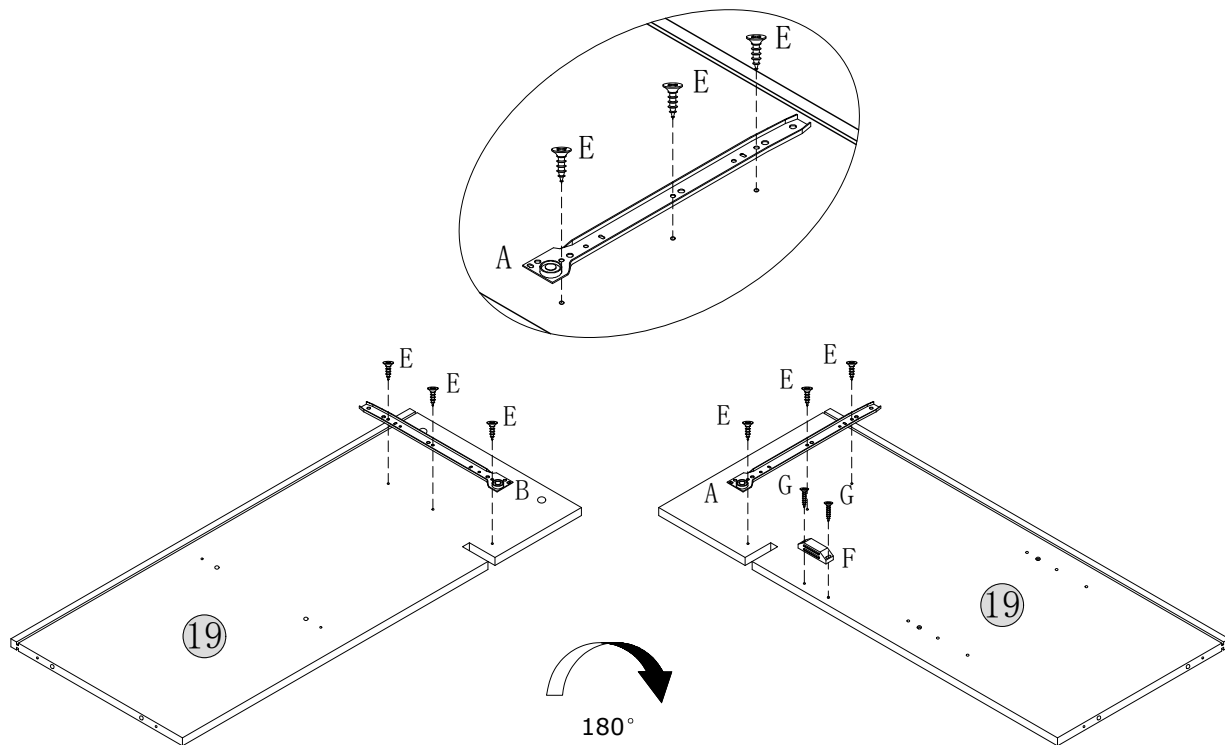

A × 1	B × 1	E × 6	F × 1	G × 2
				
L 300mm	L 300mm	∅3 × 12mm		∅3 × 14mm

2



A × 1	B × 1	E × 6	F × 1	G × 2
				
		∅3 × 12mm		∅3 × 14mm

3

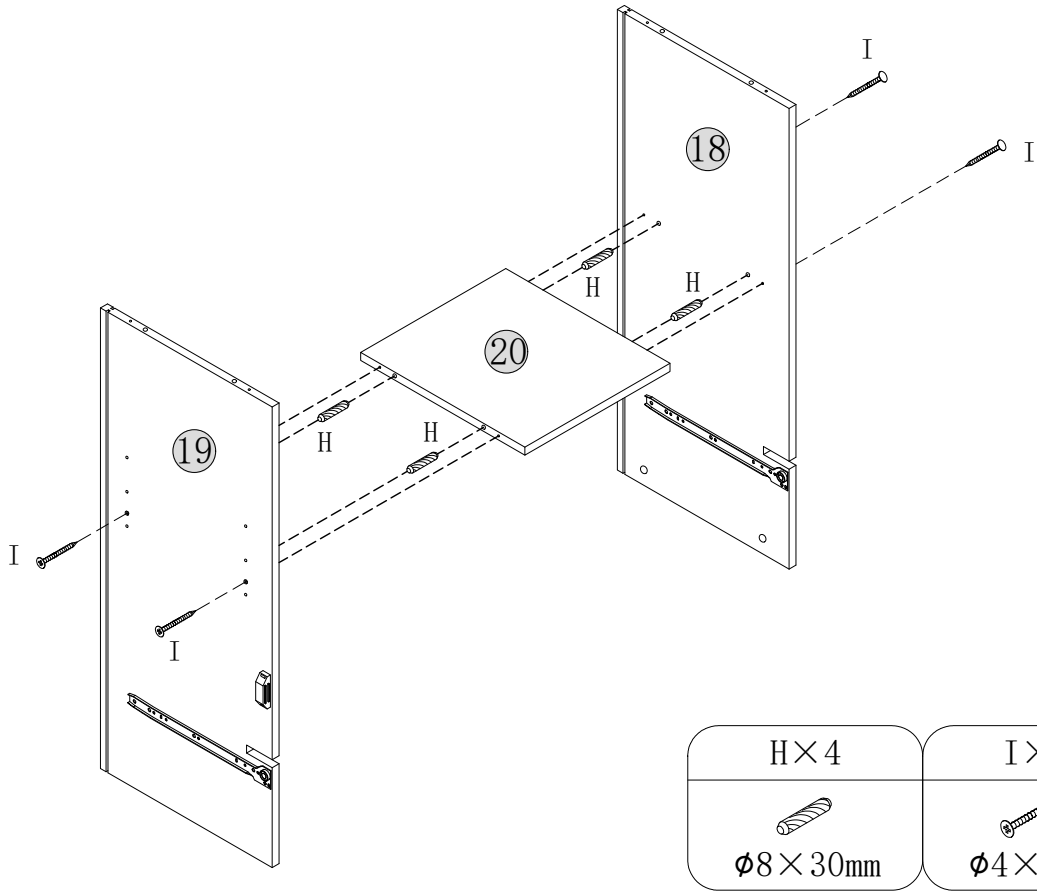

4

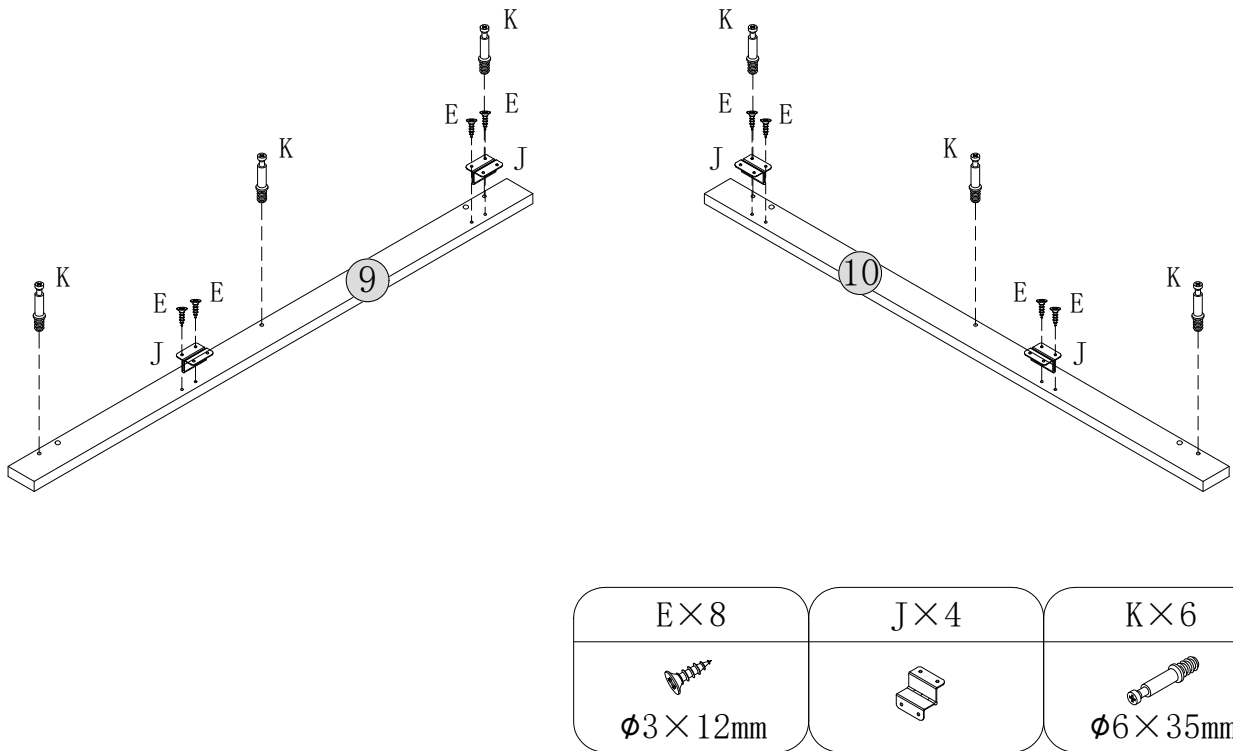

5

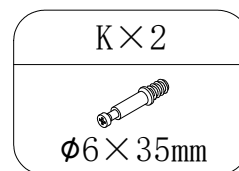
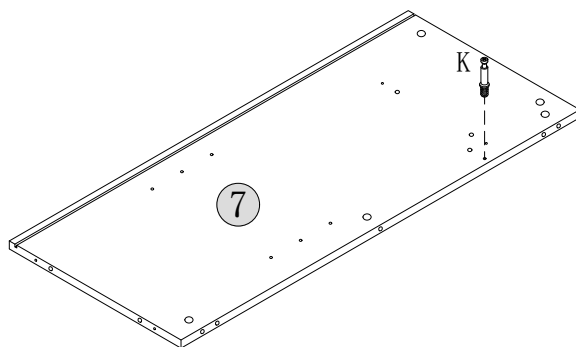
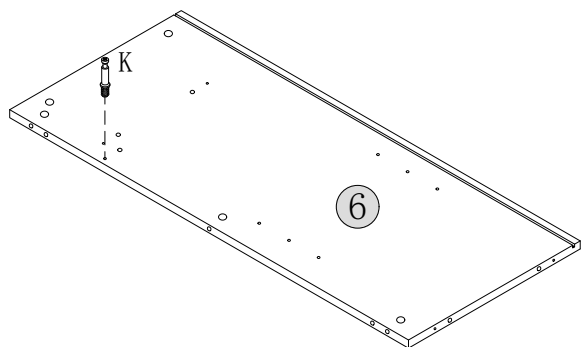

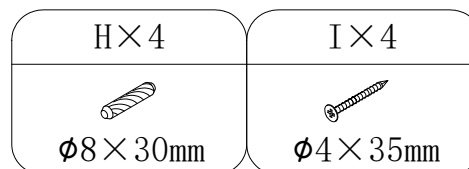
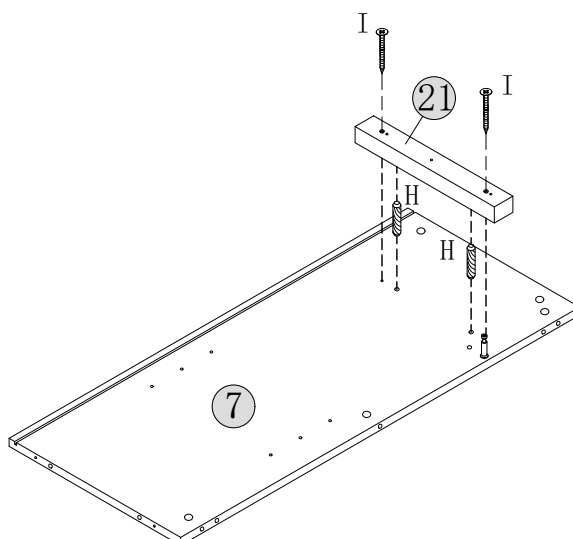
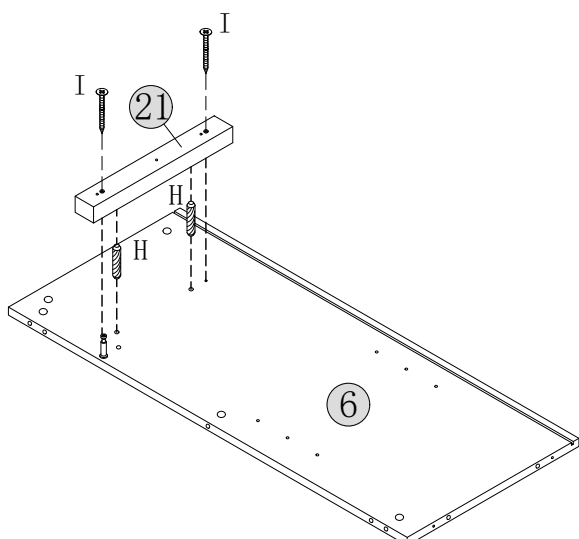

6



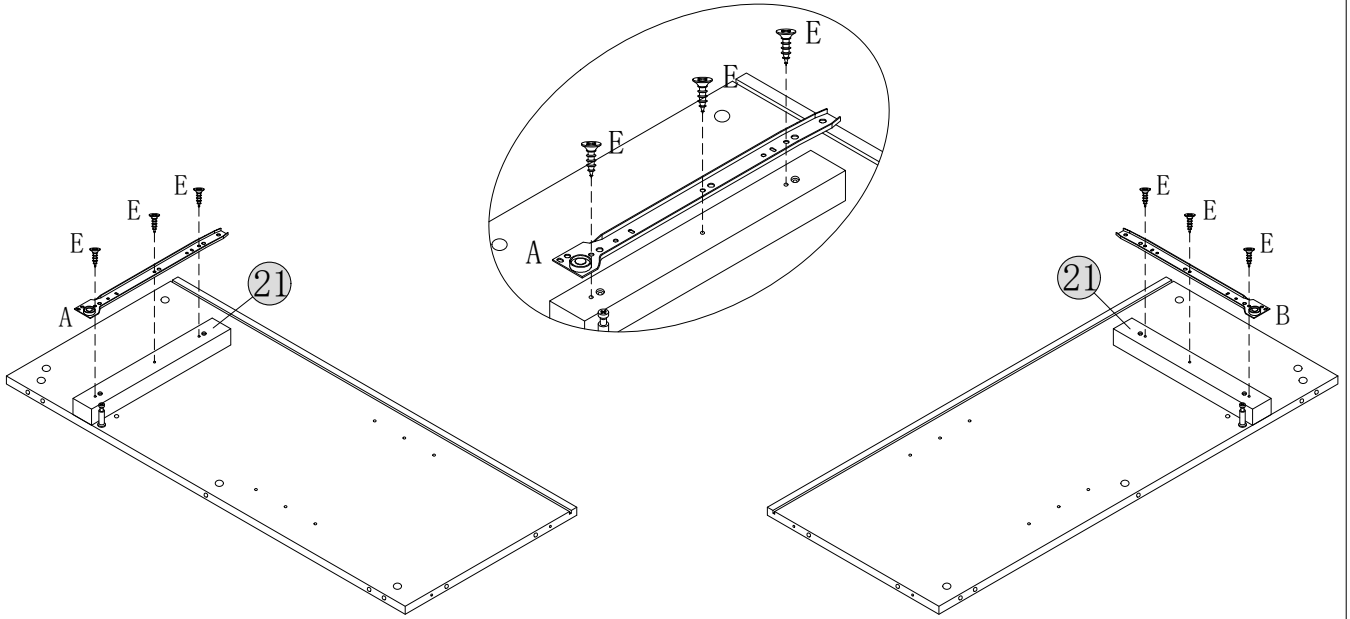

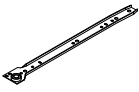
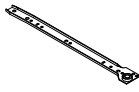
7

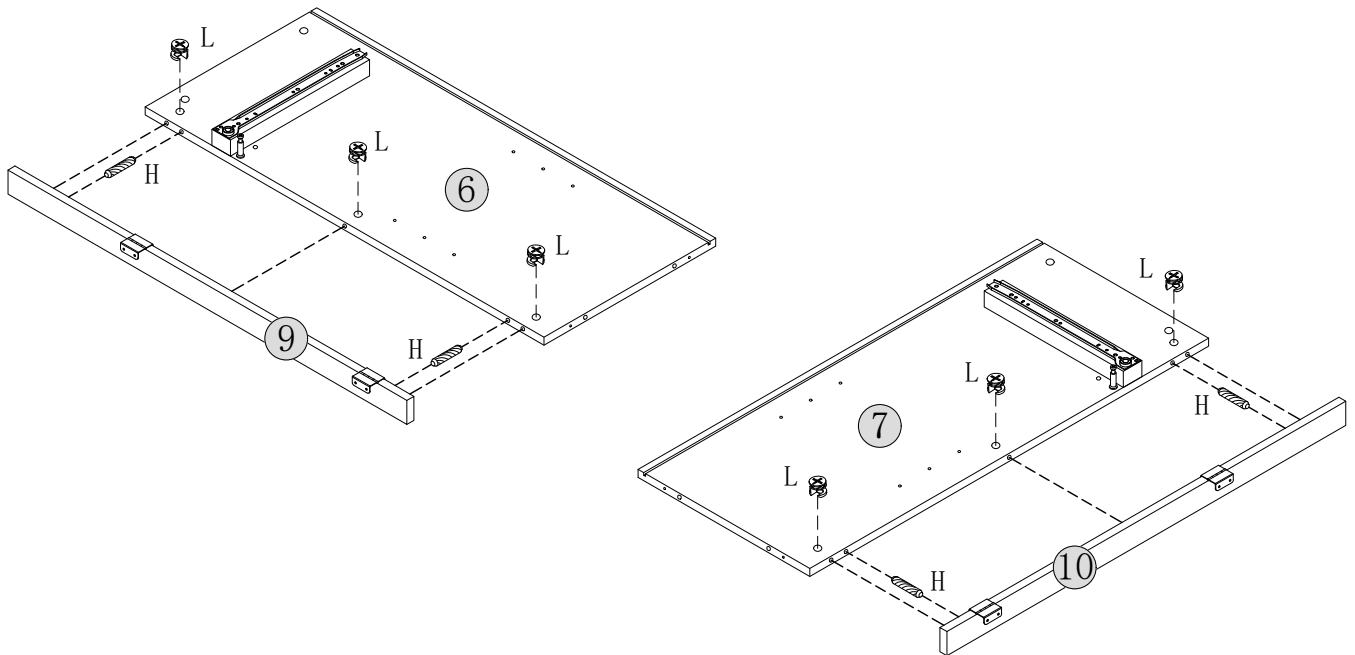

A × 1	B × 1	E × 6
		
		∅3 × 12mm

8



H × 4	L × 6
	
∅8 × 30mm	∅15 × 10mm

9

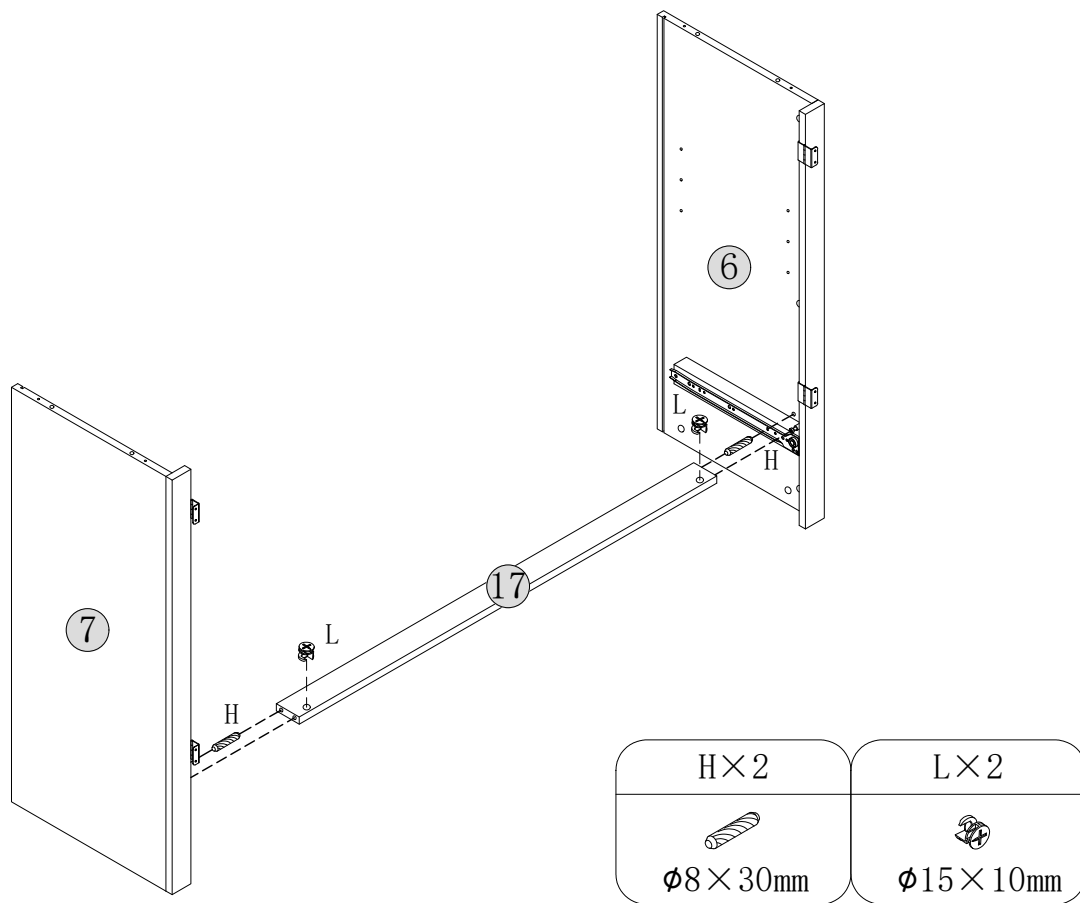

10

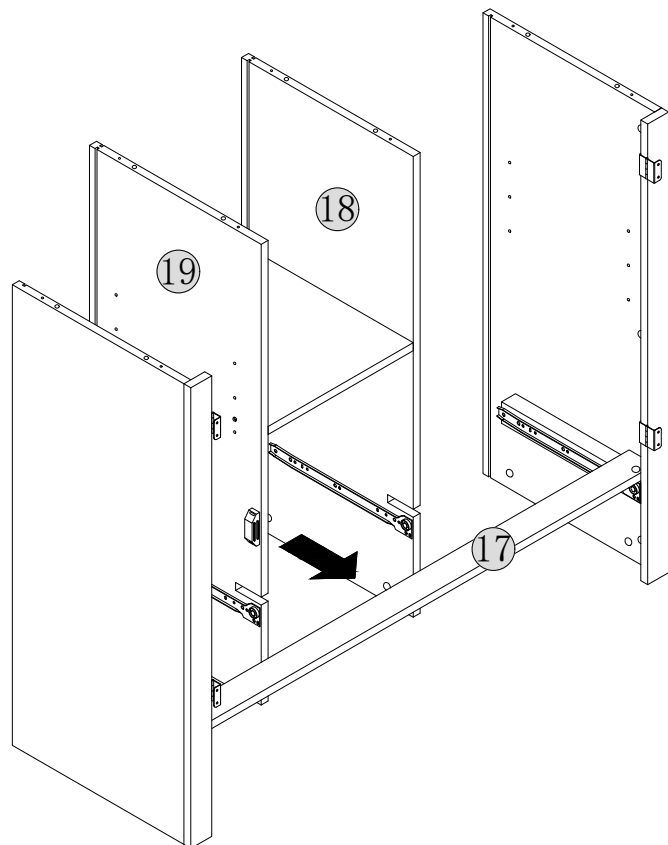

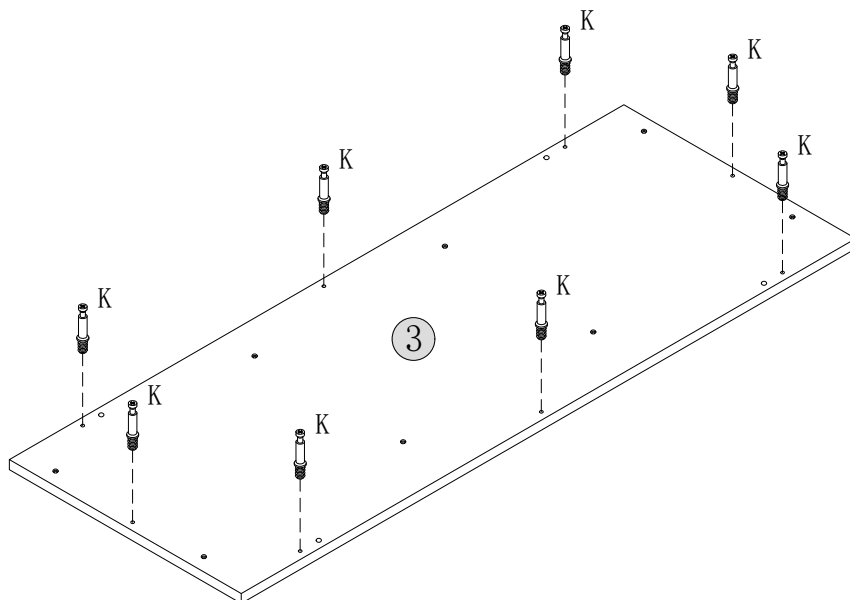

11

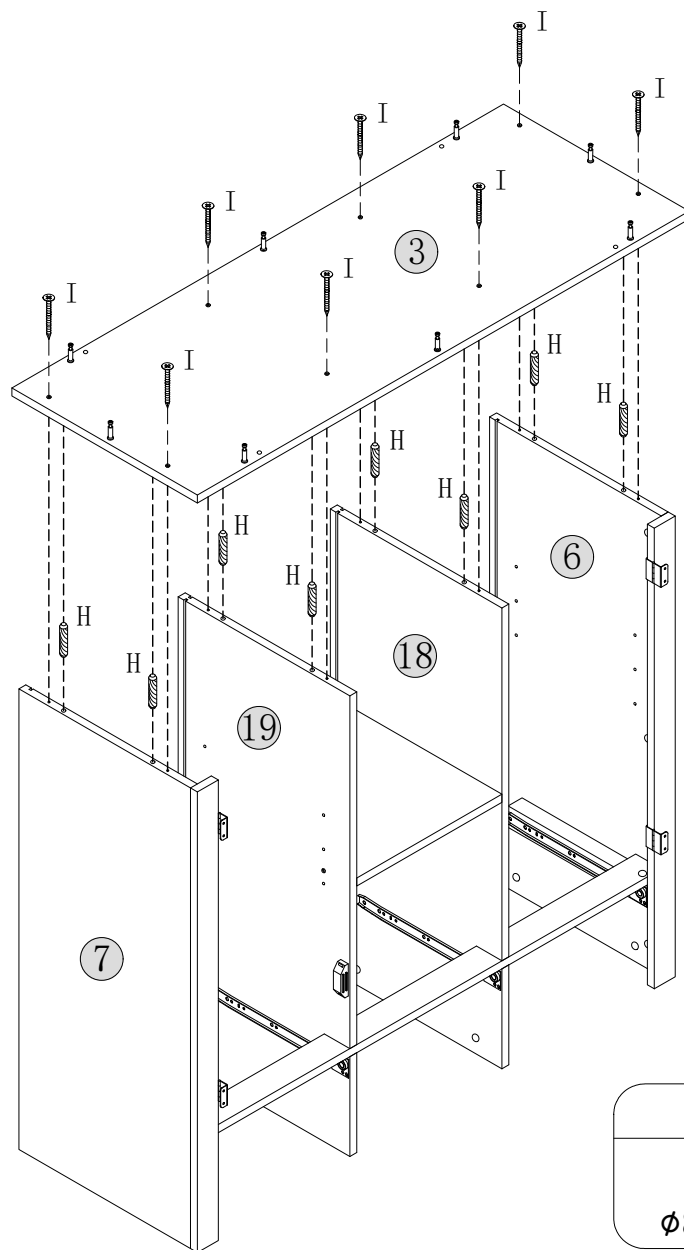

$K \times 8$

$\phi 6 \times 35\text{mm}$

12

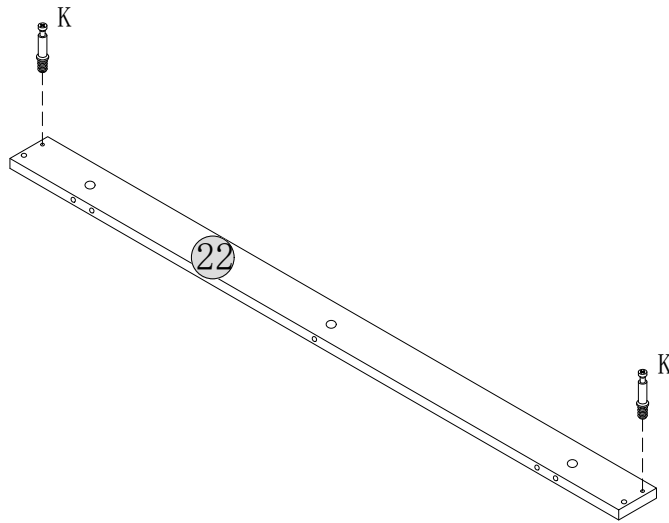

$H \times 8$	$I \times 8$
	
$\phi 8 \times 30\text{mm}$	$\phi 4 \times 35\text{mm}$

13





×2

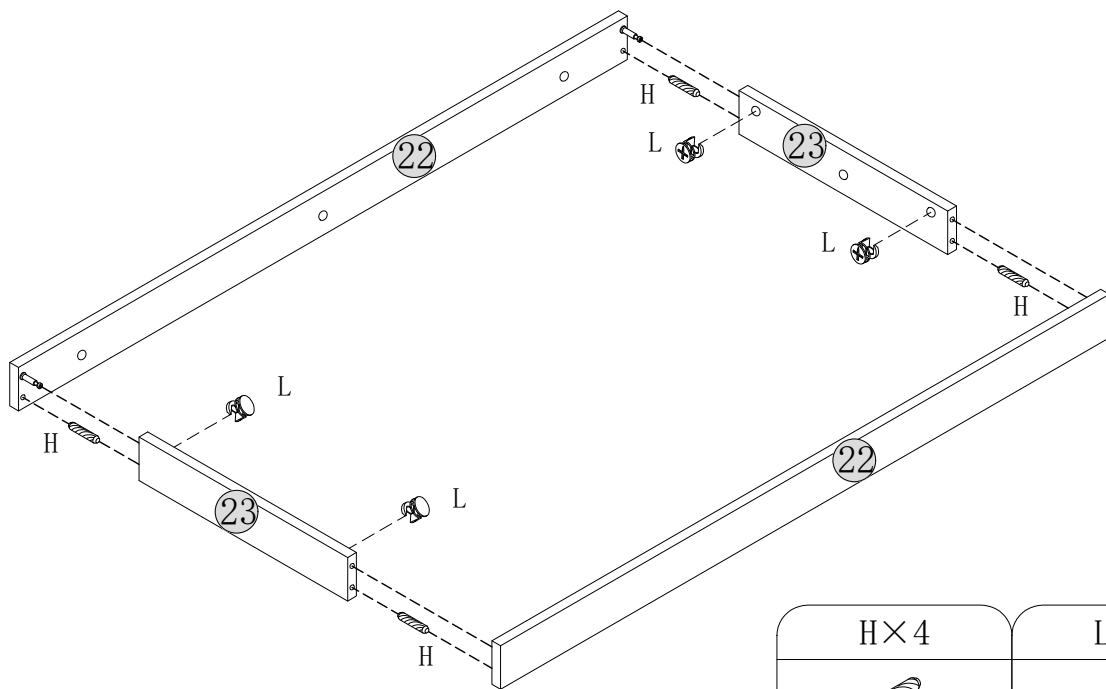

K × 4

φ6 × 35mm

14

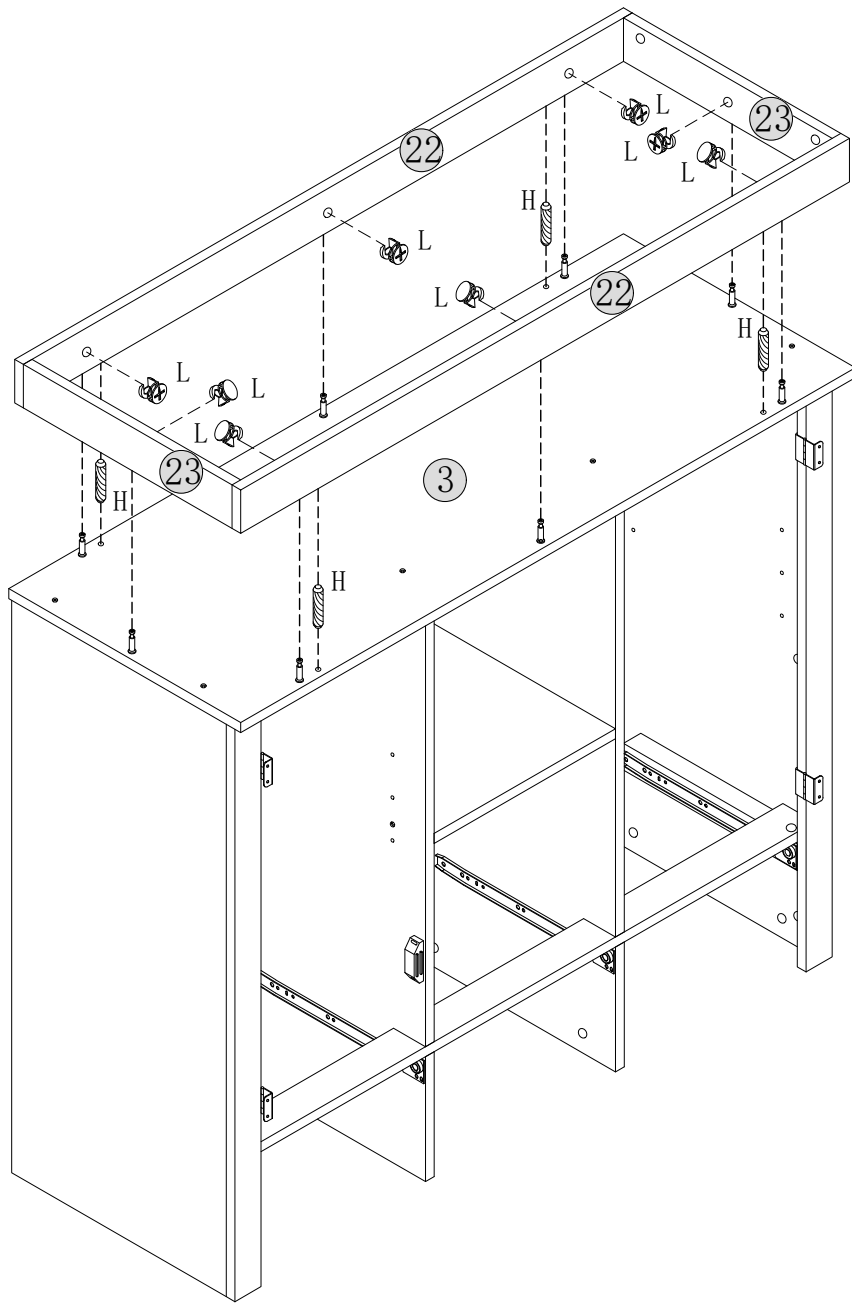



H × 4	L × 4
	
φ8 × 30mm	φ15 × 10mm



H × 4	L × 8
	
Ø8 × 30mm	Ø15 × 10mm

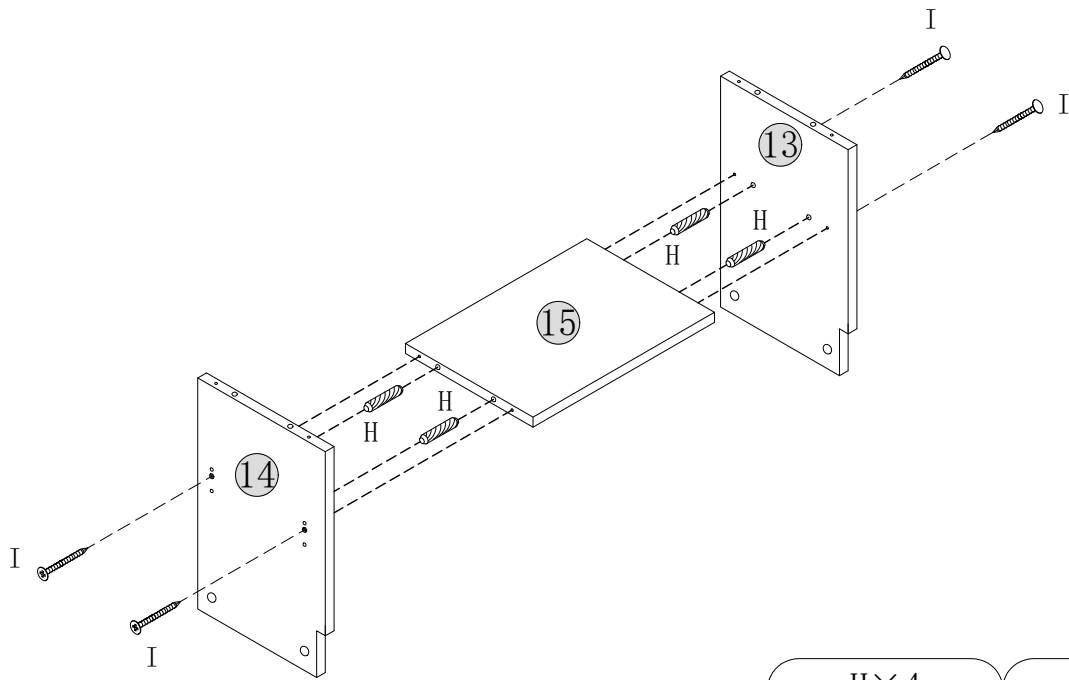

16

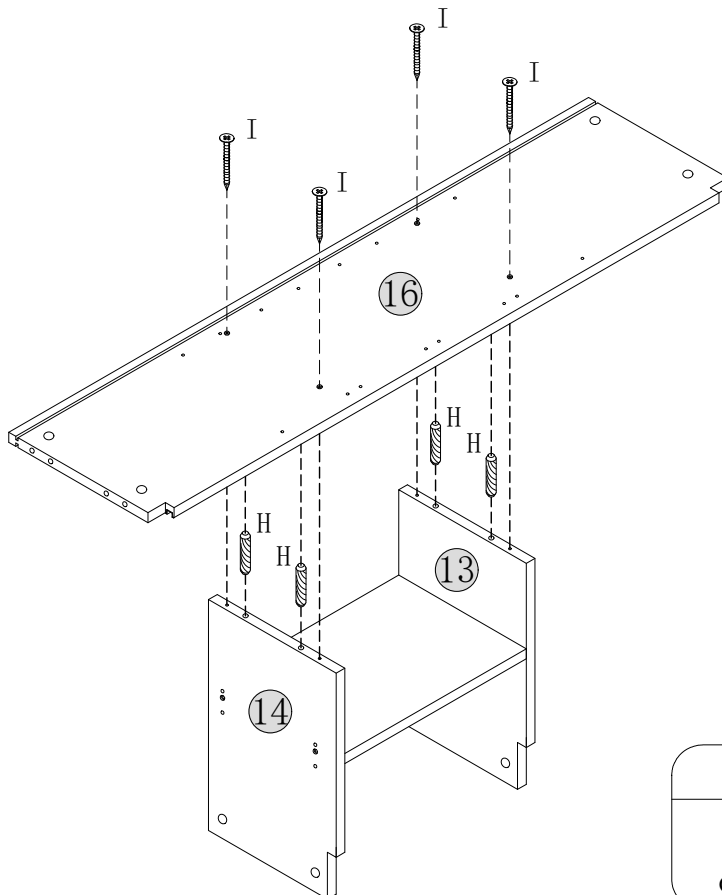

H × 4	I × 4
	
∅8 × 30mm	∅4 × 35mm

17



H × 4	I × 4
	
∅8 × 30mm	∅4 × 35mm

18

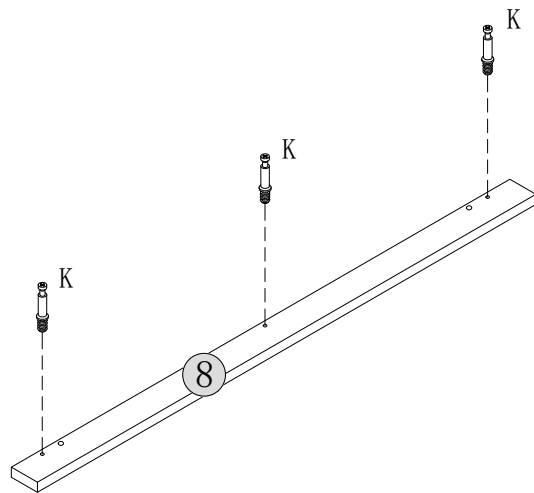

×2

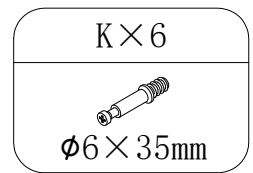

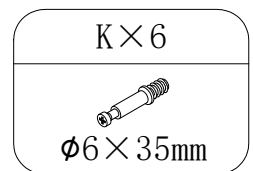
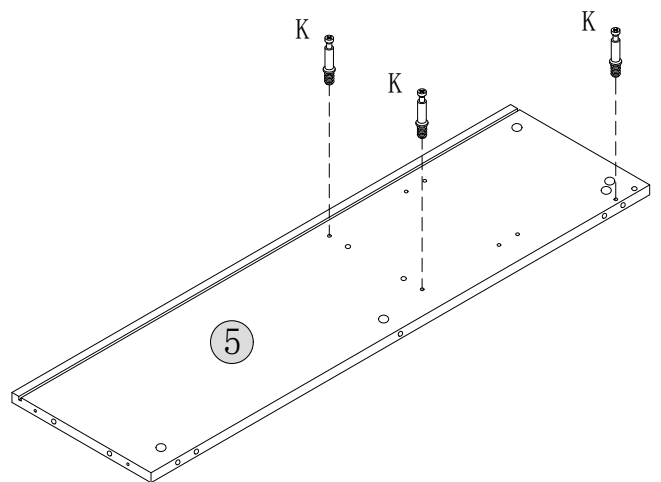
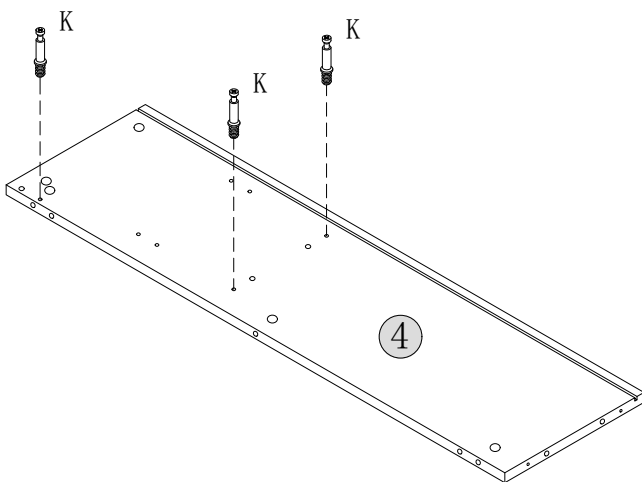

19



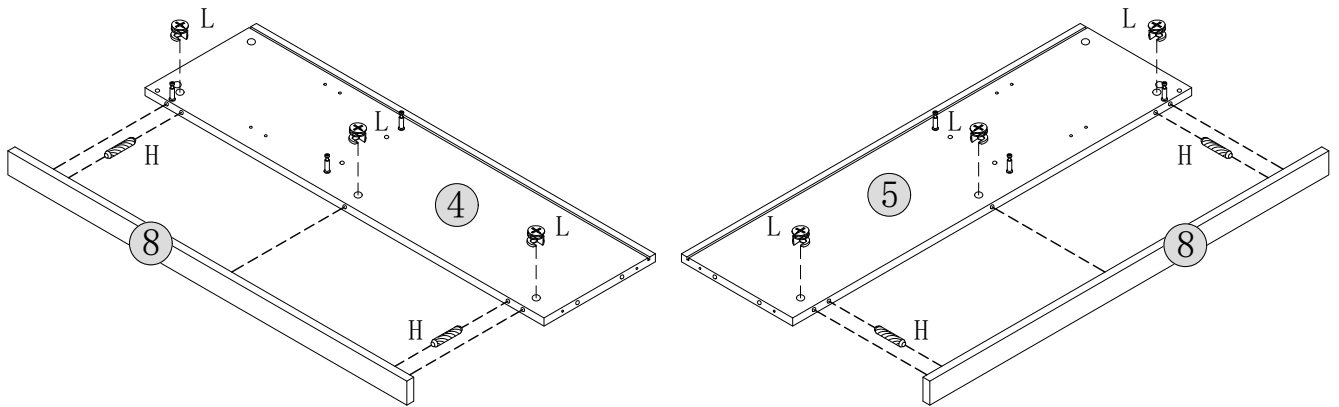

20

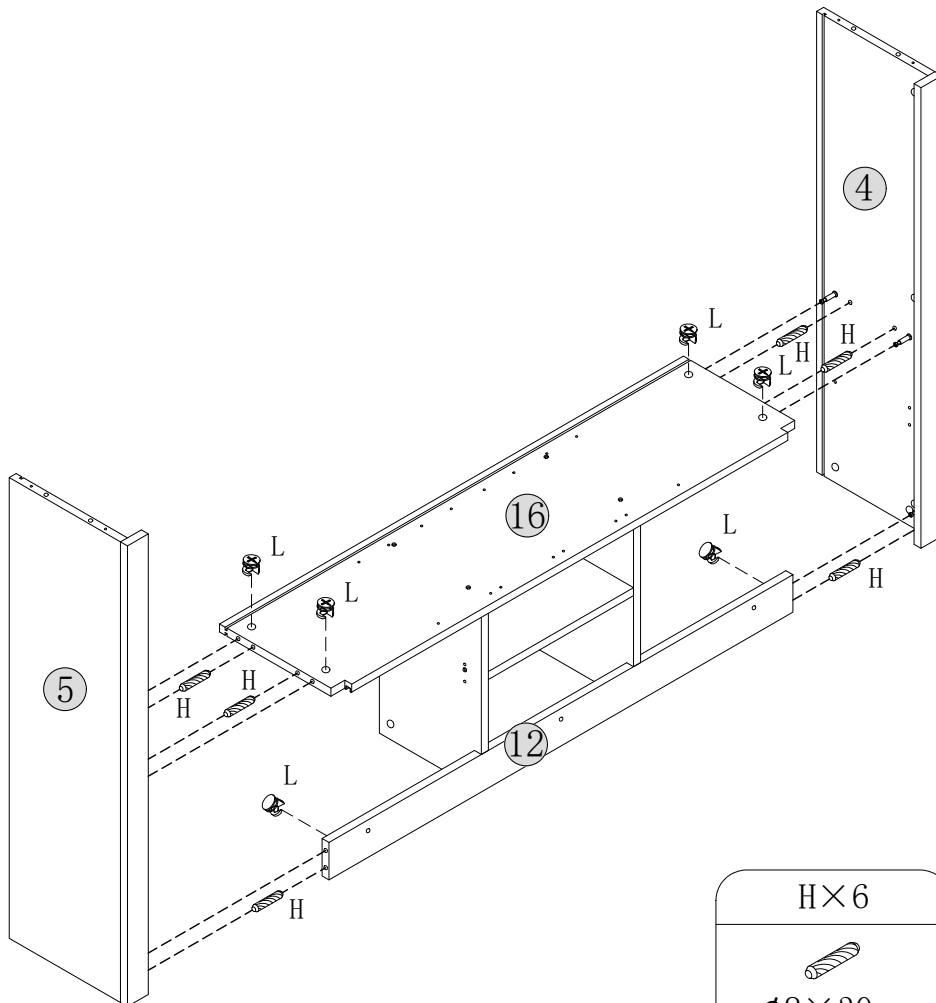

H×4	L×6
	
φ8×30mm	φ15×10mm

21



H×6	L×6
	
φ8×30mm	φ15×10mm

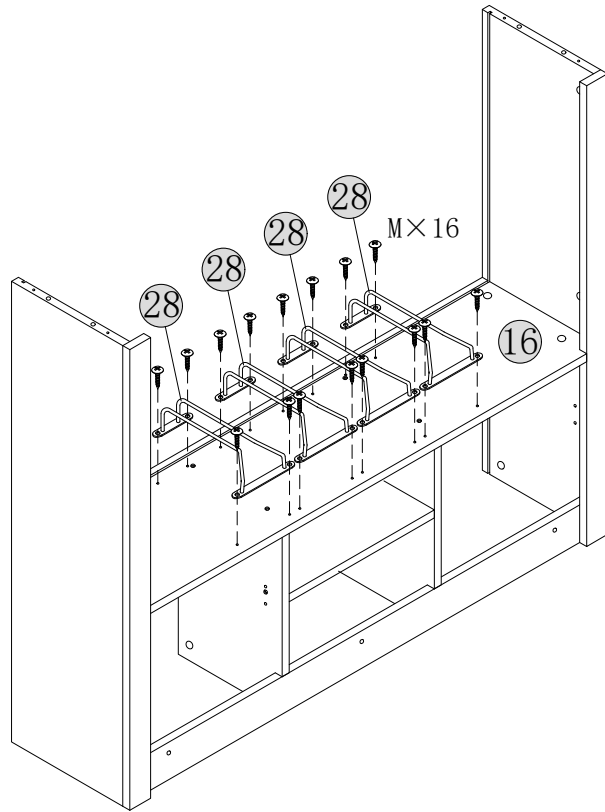

22

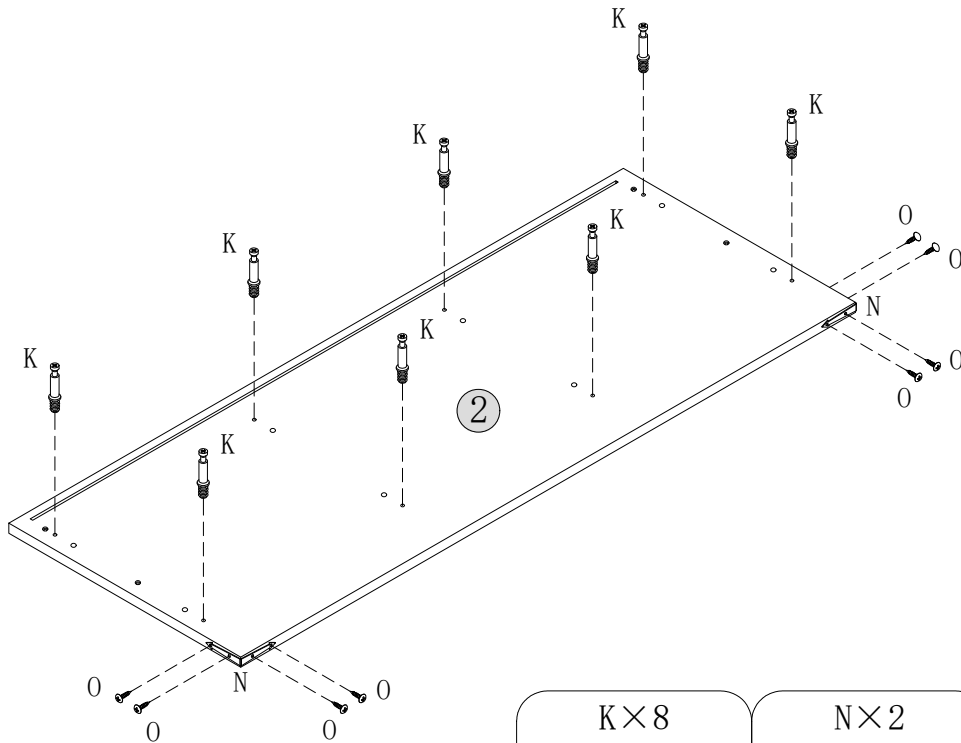

M×16

Ø4×14mm



23

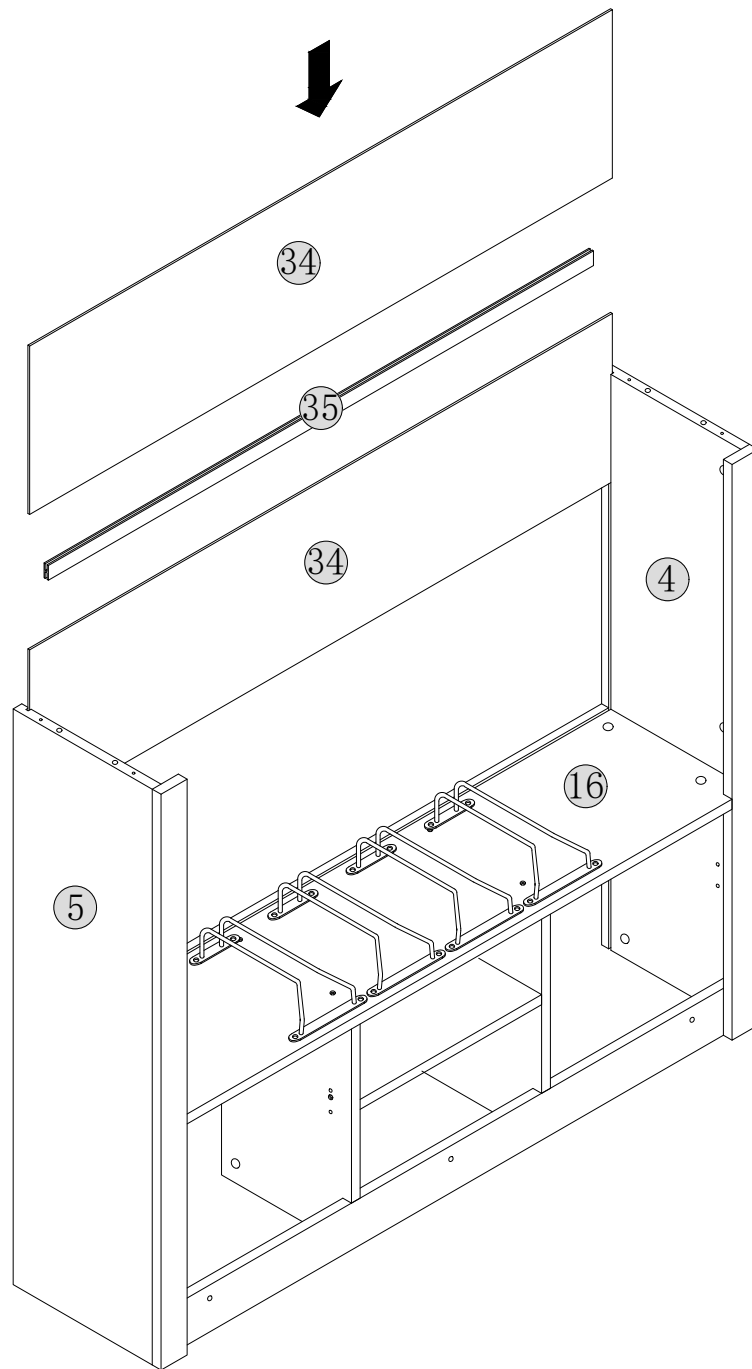

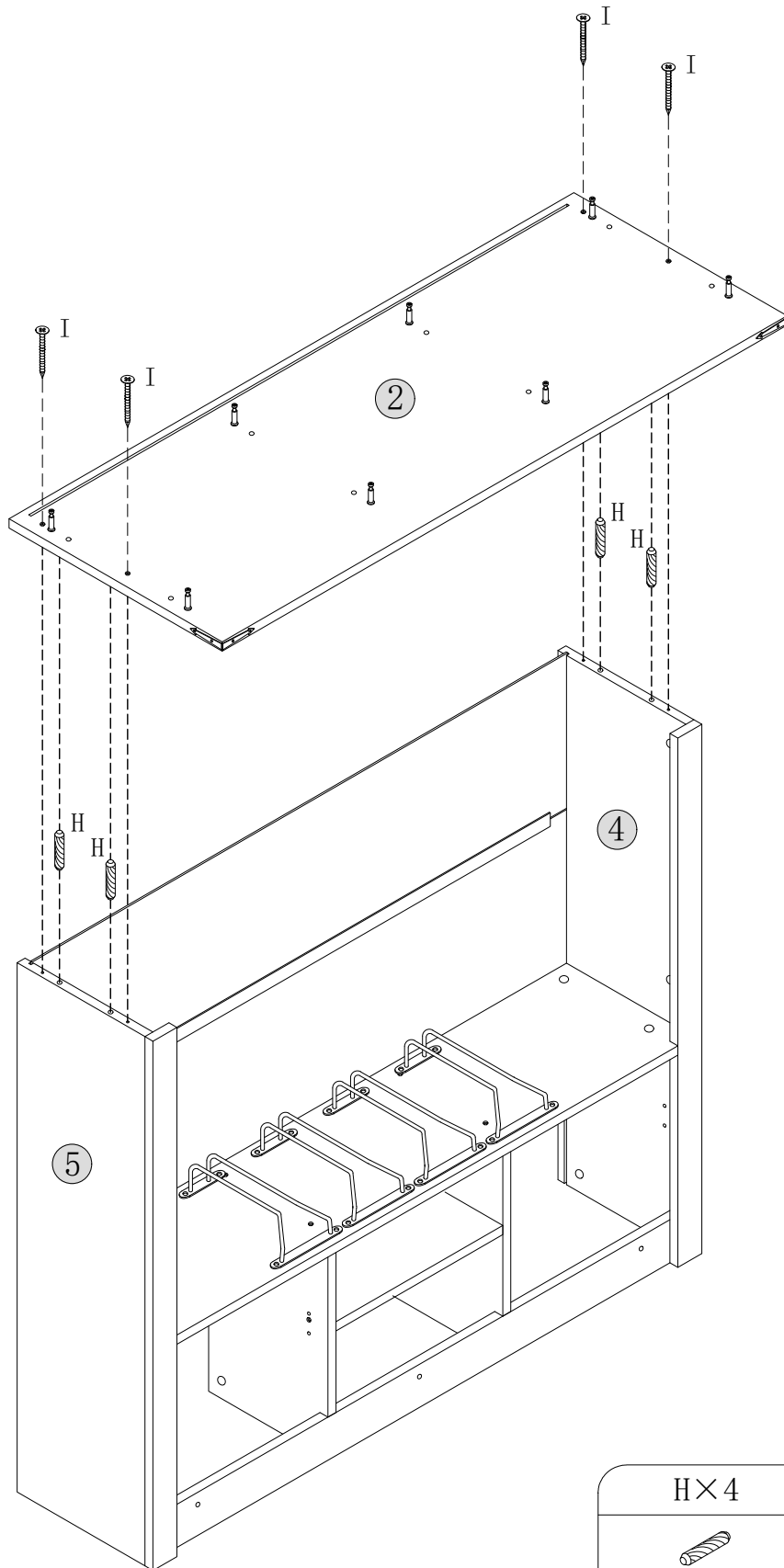
K×8	N×2	O×8
		
Ø6×35mm		Ø3×12mm







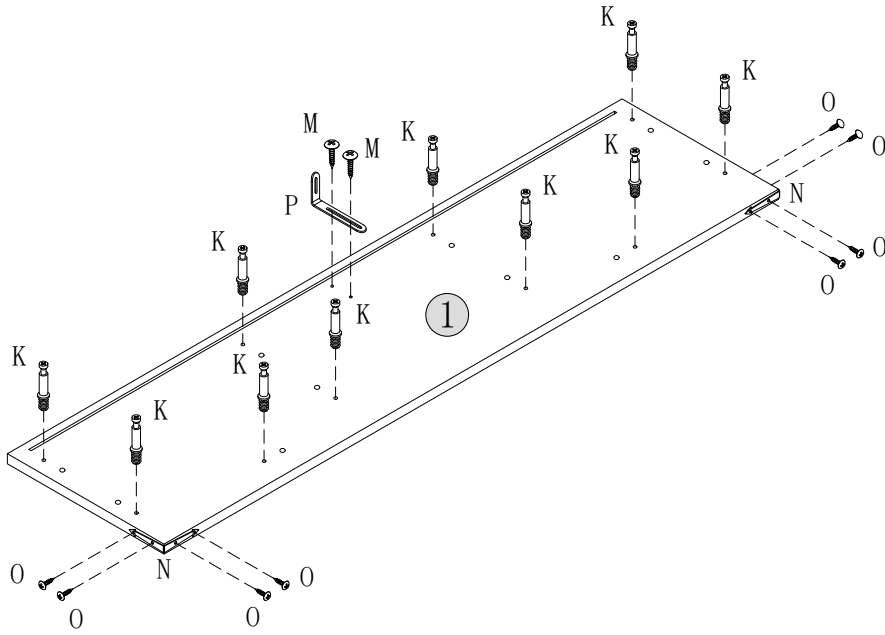

H × 4	I × 4
	
∅8 × 30mm	∅4 × 35mm

26



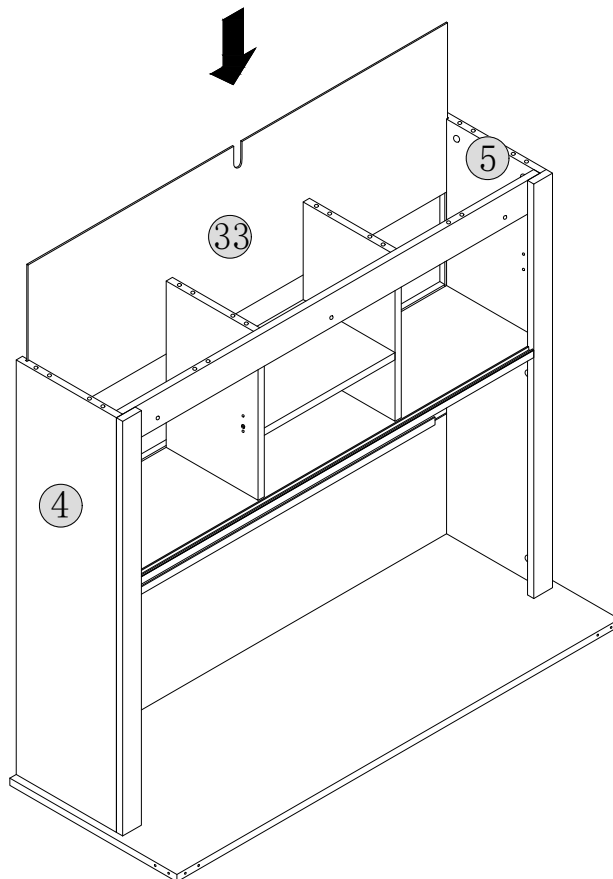

K × 10	M × 2	N × 2	O × 8	P × 1
				
φ6 × 35mm	φ4 × 14mm		φ3 × 12mm	

27

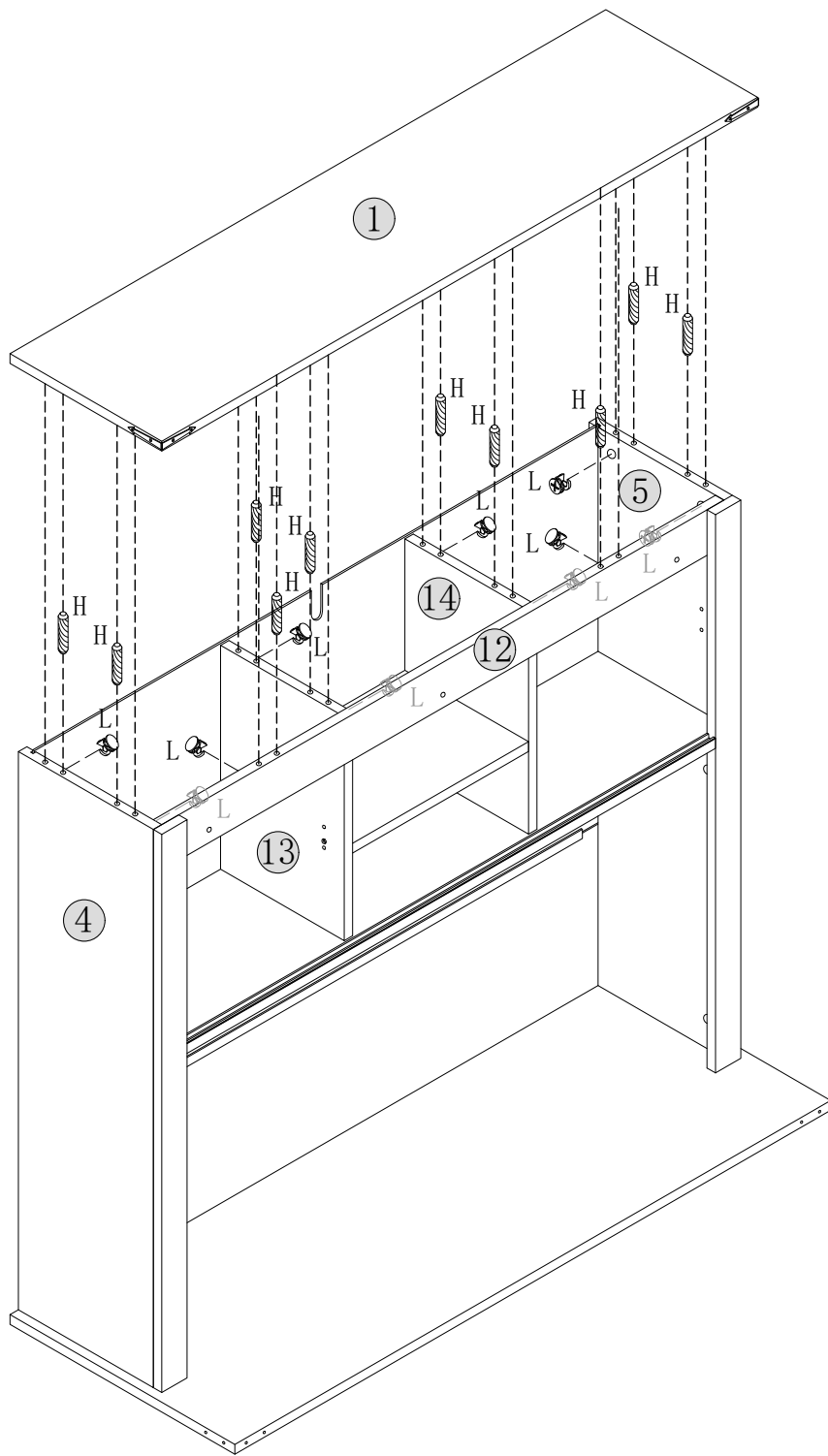



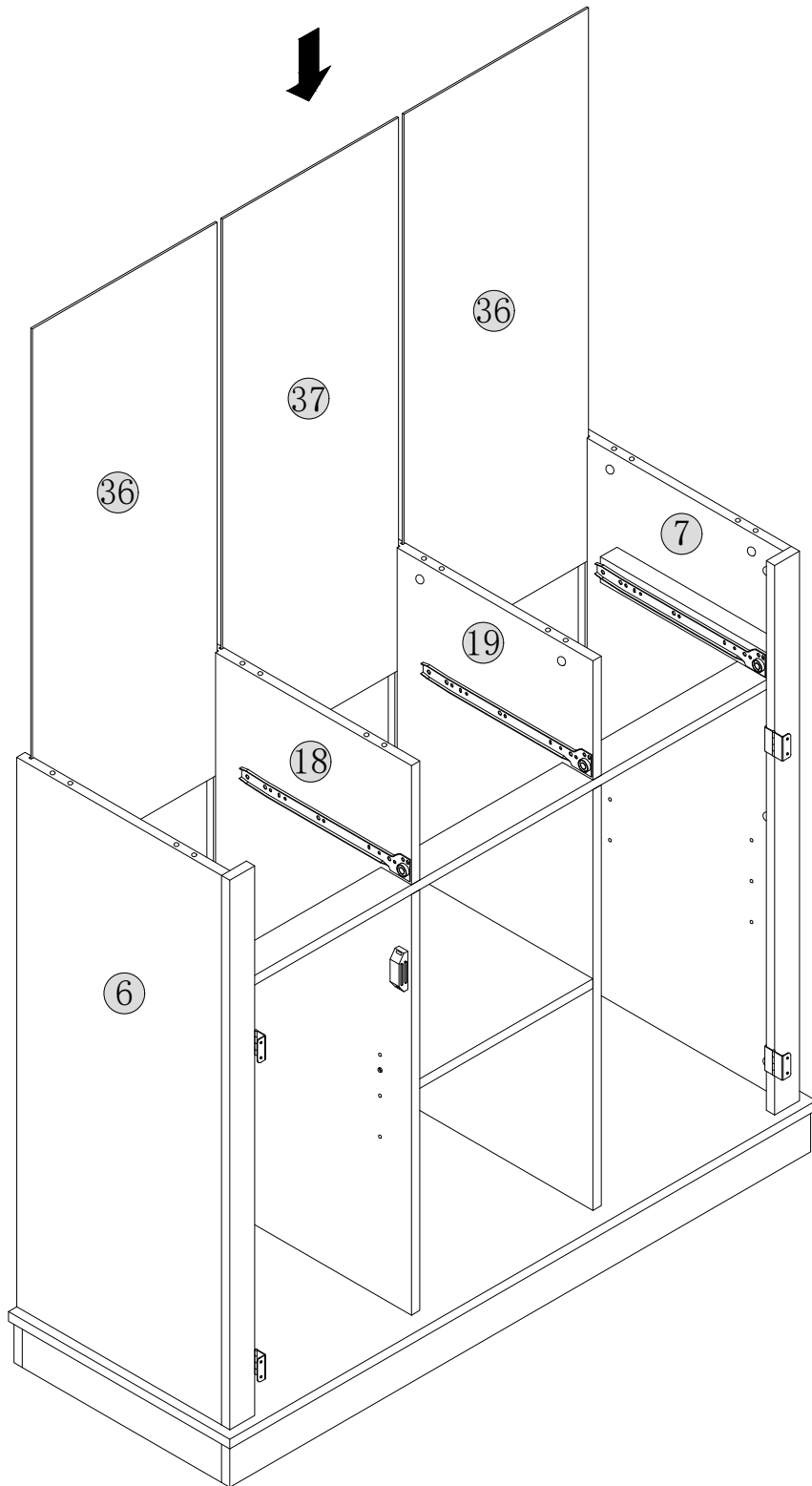

H × 10	L × 10
	
φ8 × 30mm	φ15 × 10mm

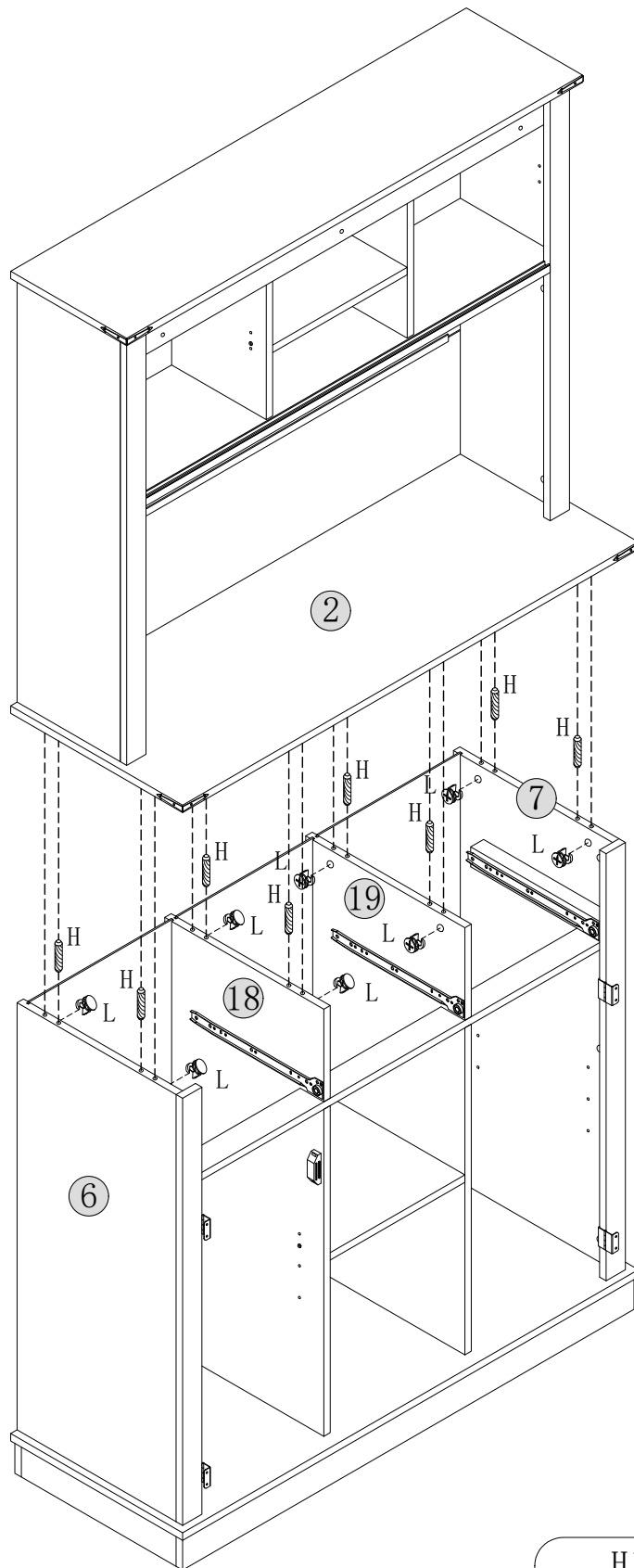



H × 8	L × 8
	
φ8 × 30mm	φ15 × 10mm

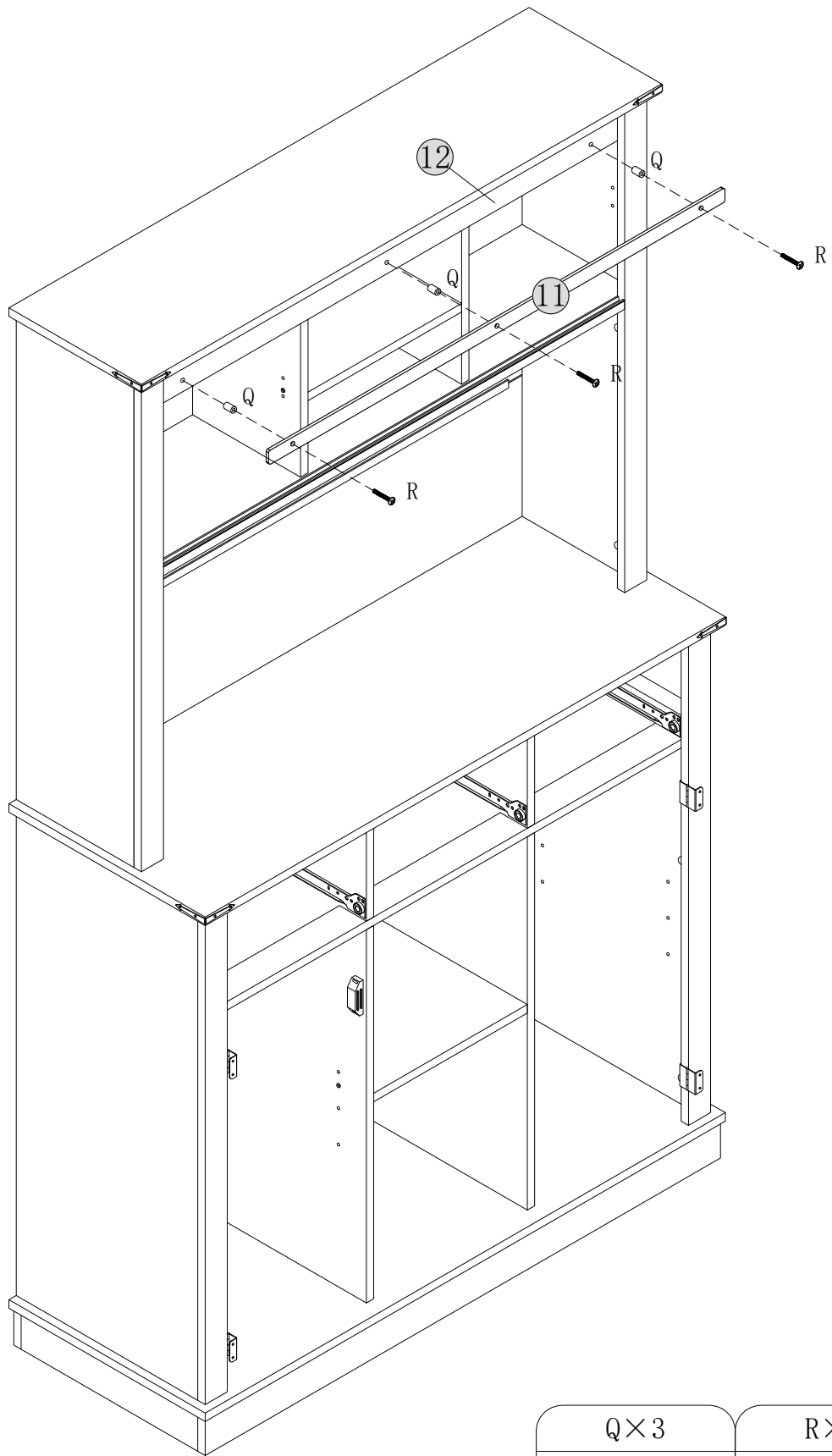

Q × 3



R × 3



Ø6 × 25mm

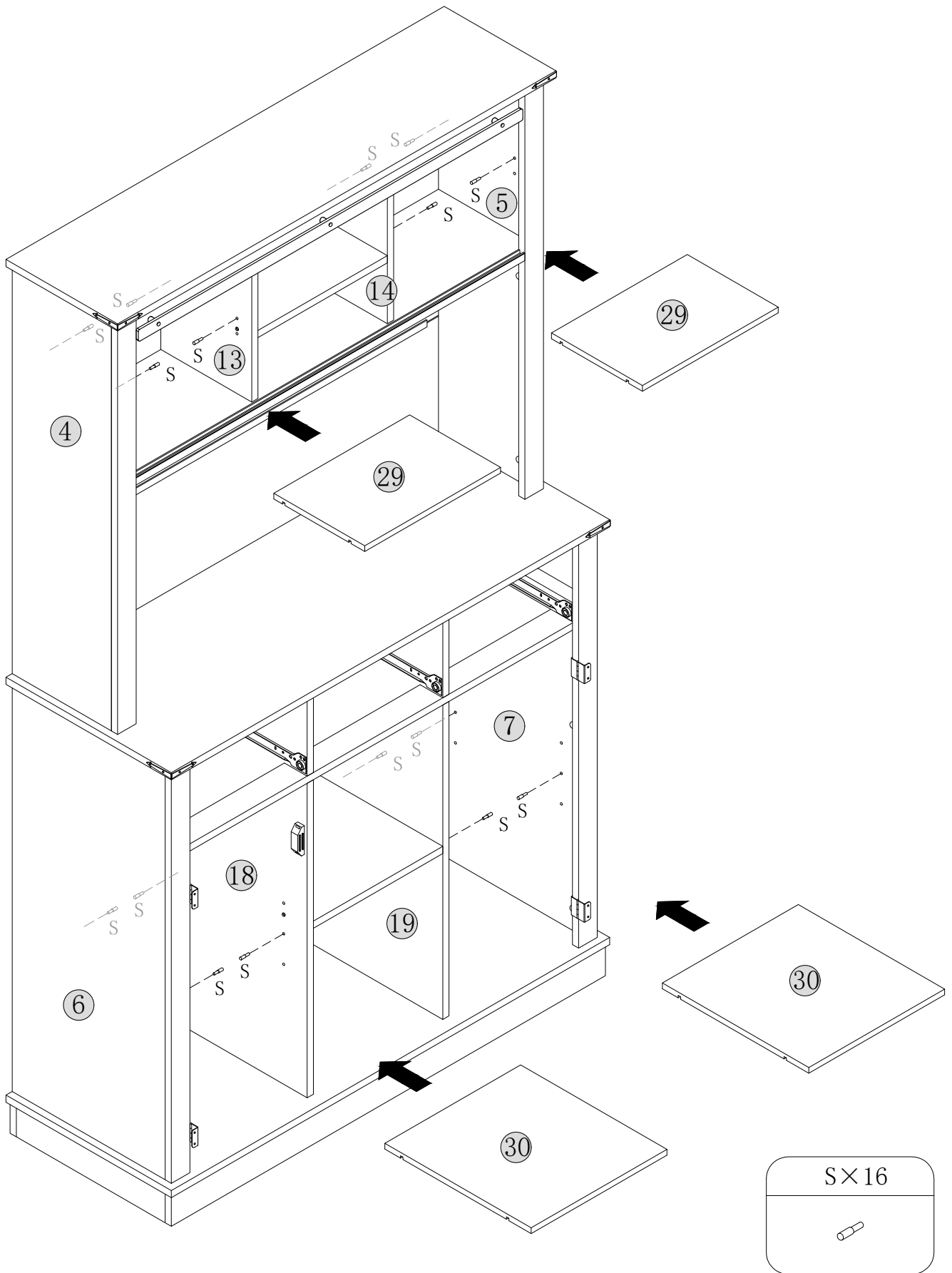

33

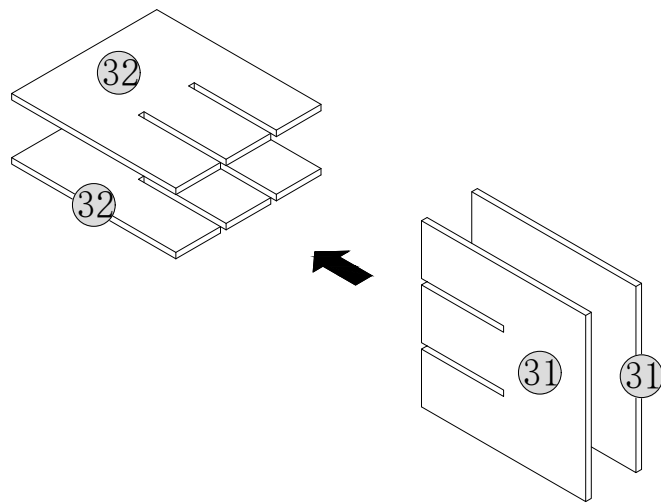

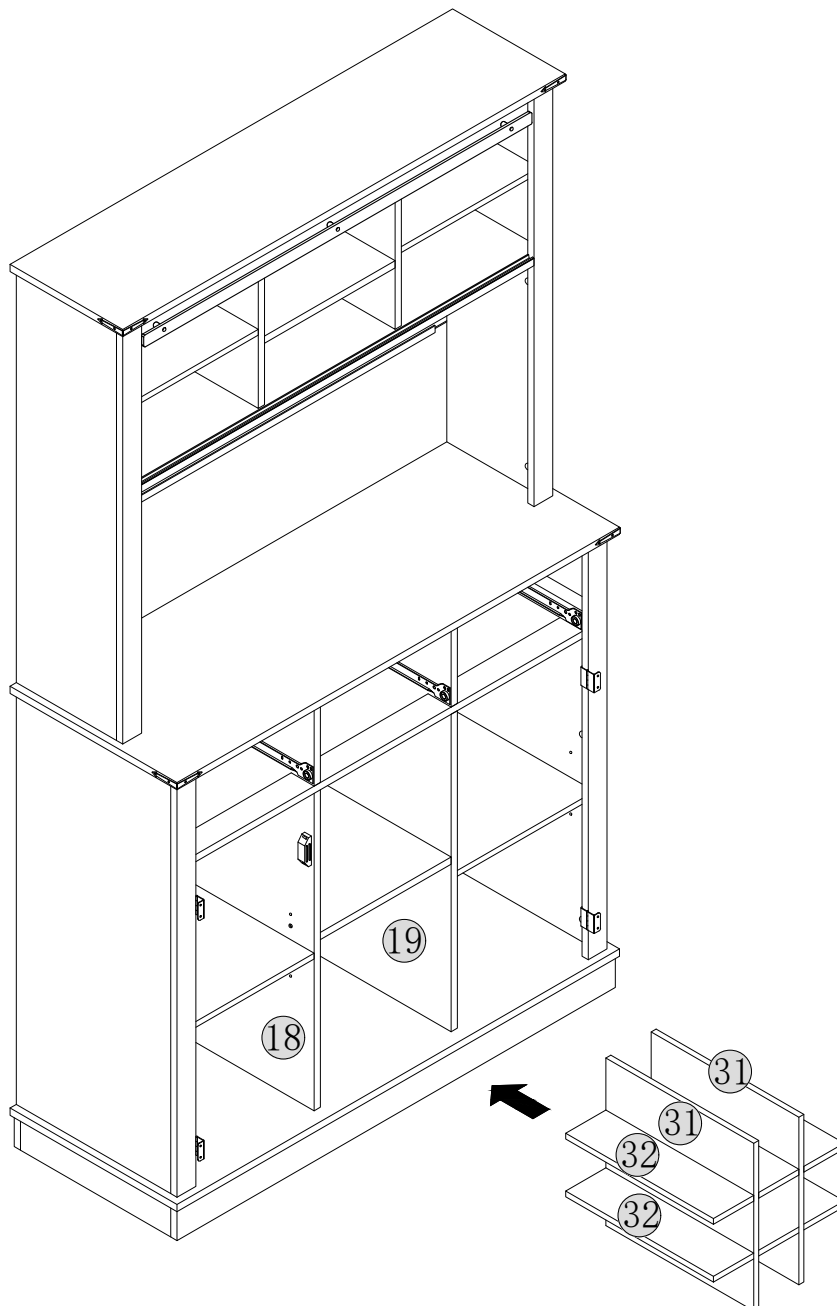

34



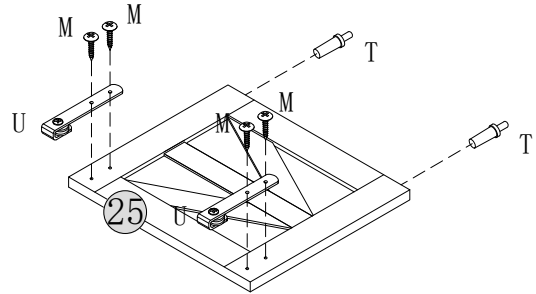
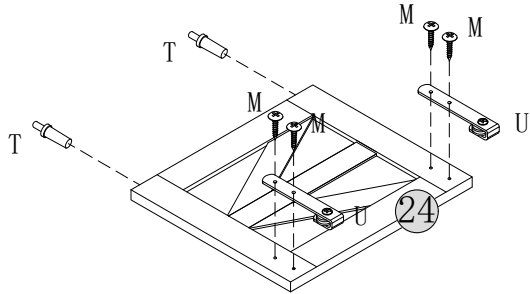

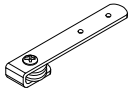

35

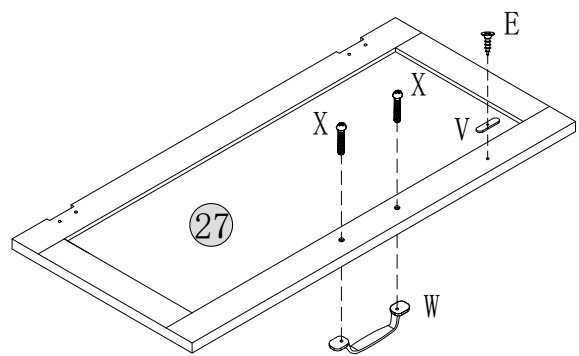
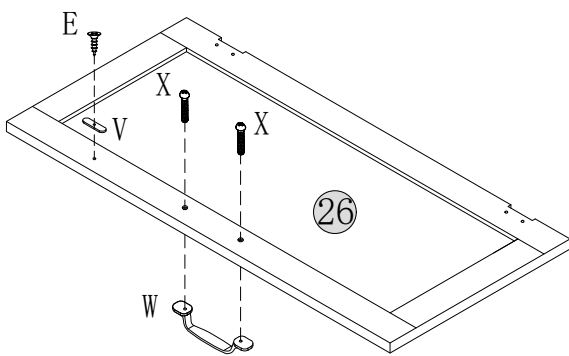

M×8	T×4	U×4
		
φ4×14mm		

36



E×2	V×2	W×2	X×4
			
φ3×12mm			φ4×18mm

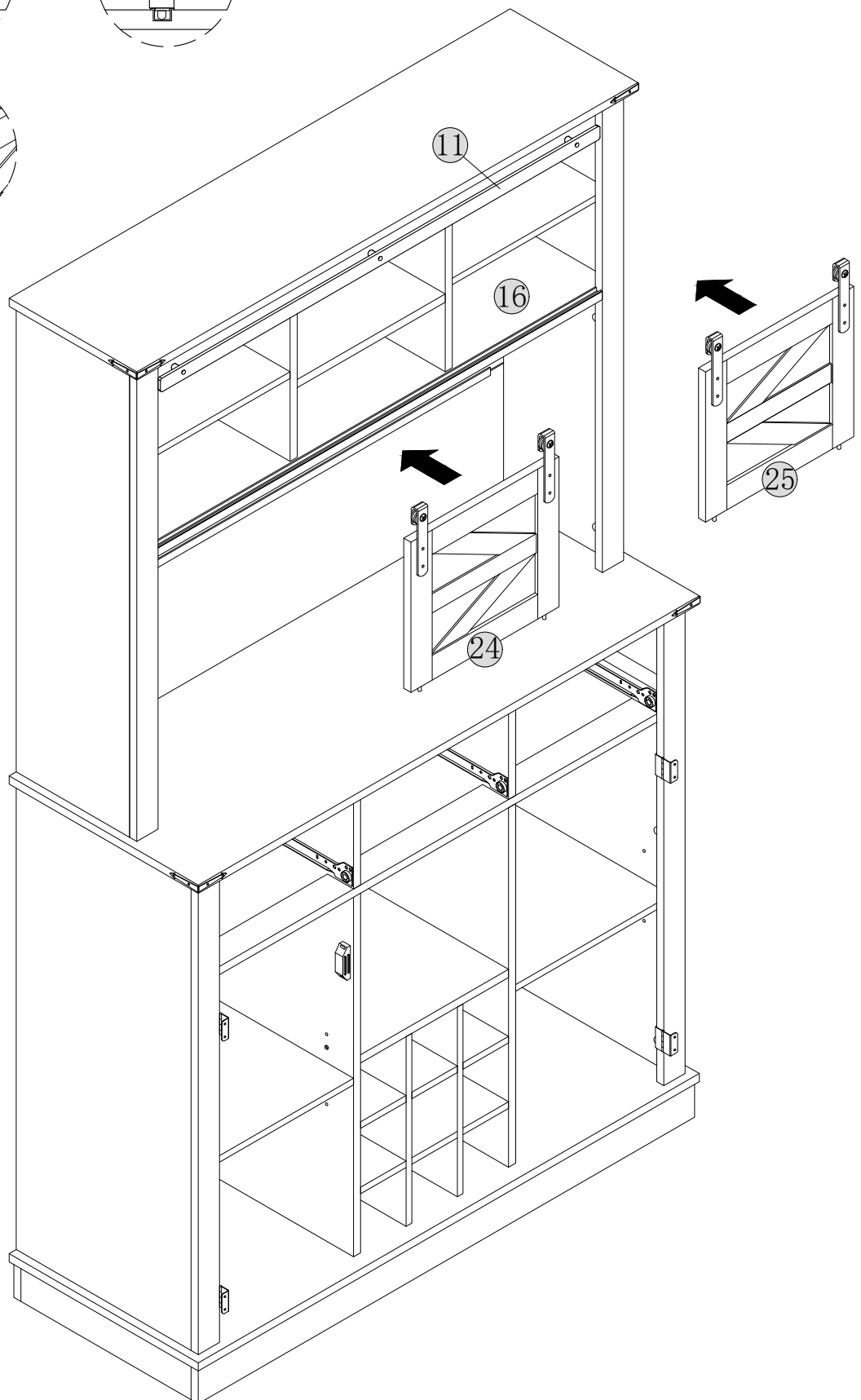
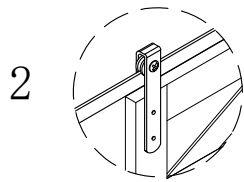
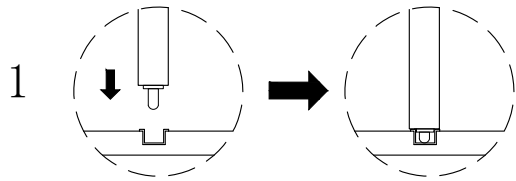

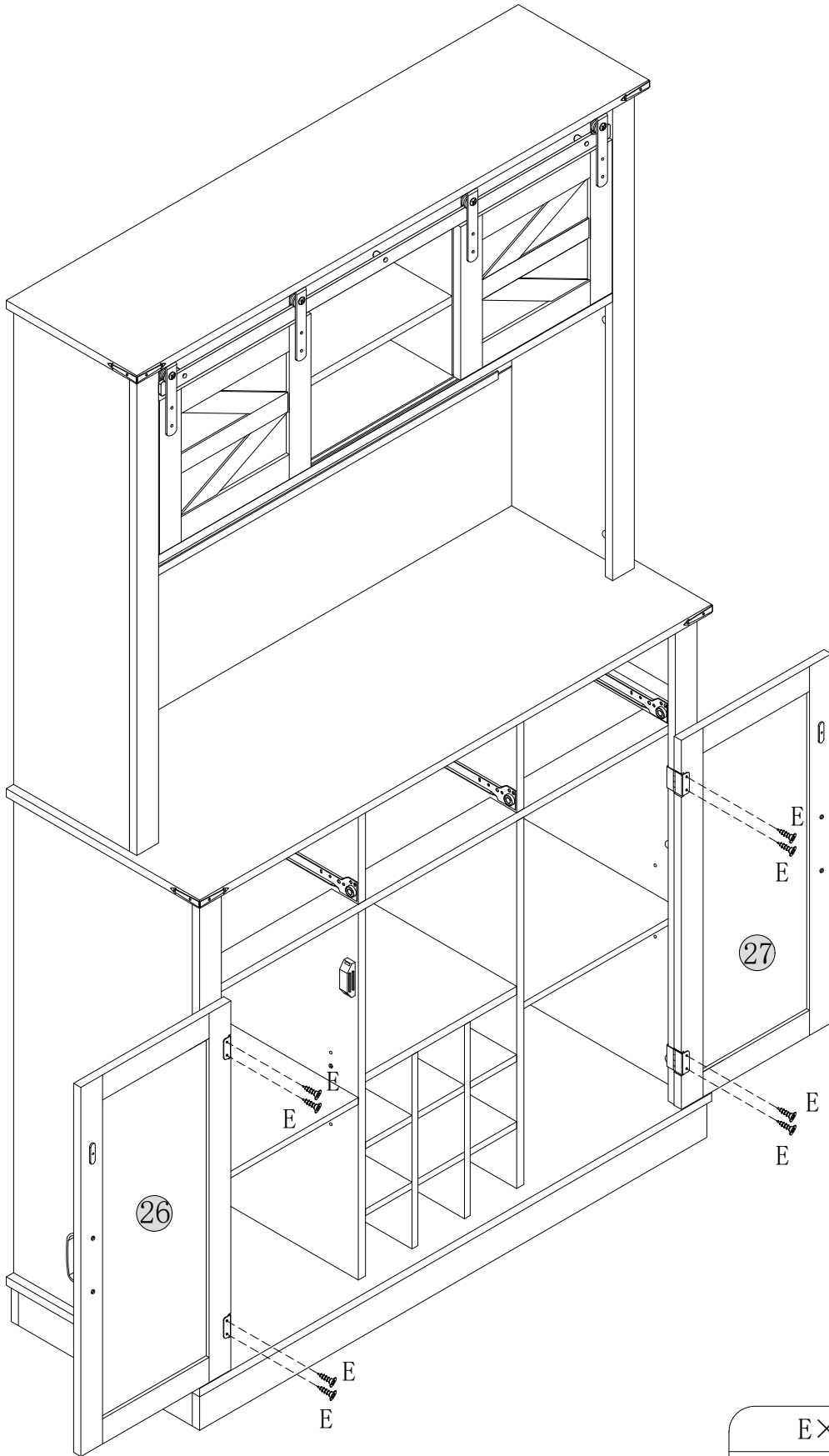

E × 8

∅3 × 12mm

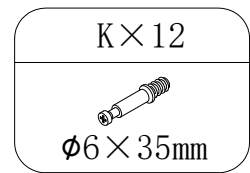
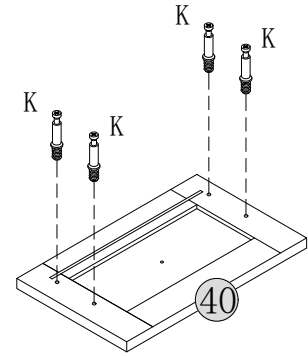
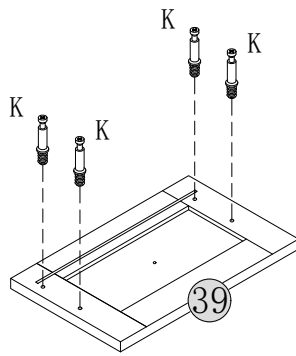
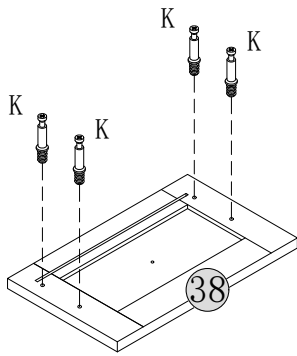
39

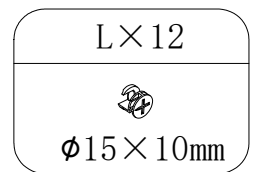
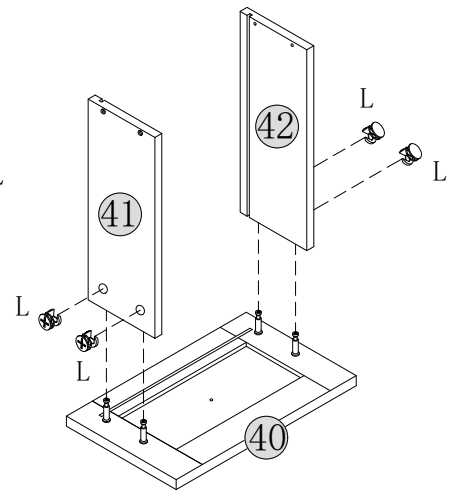
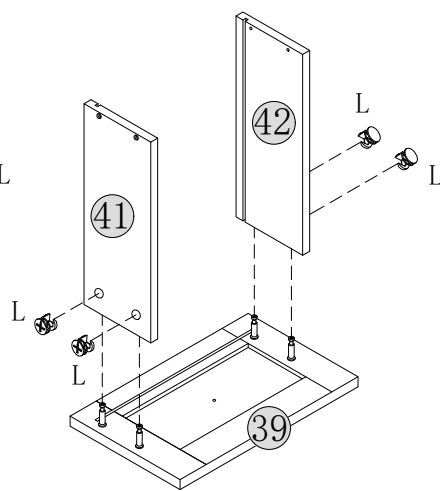
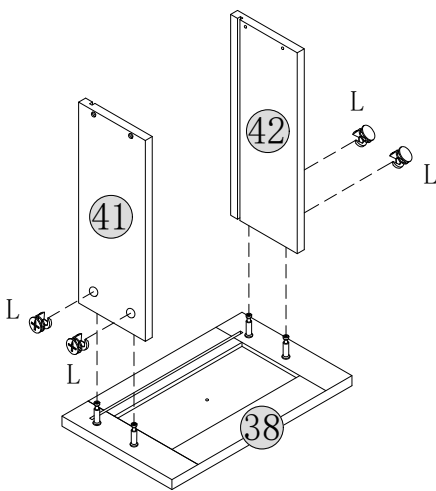

40



41

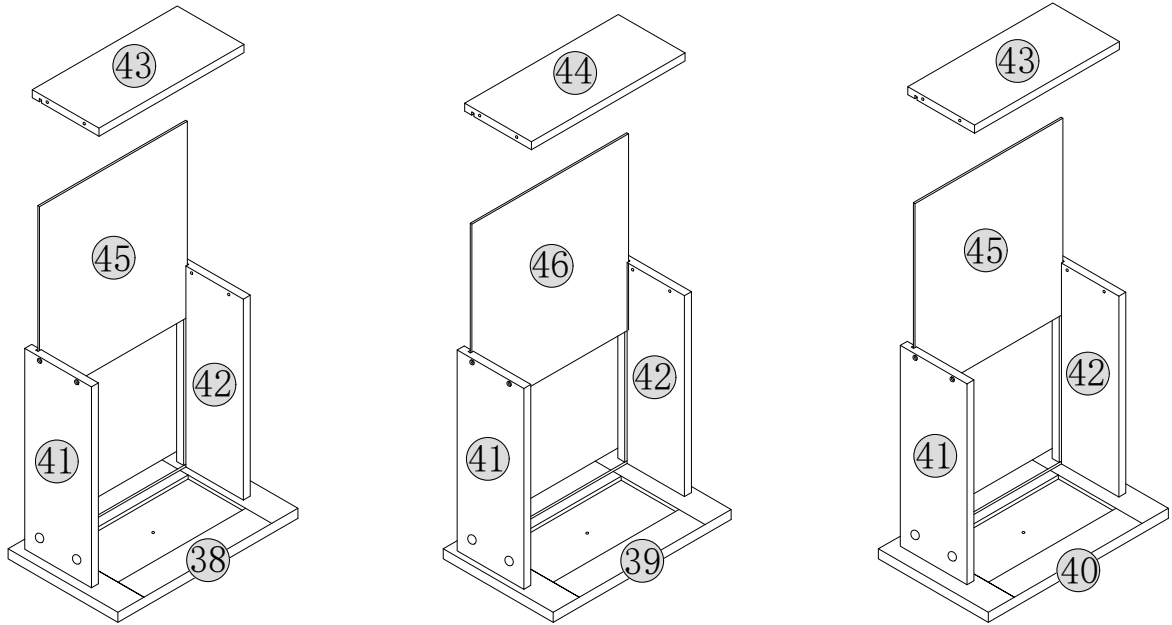

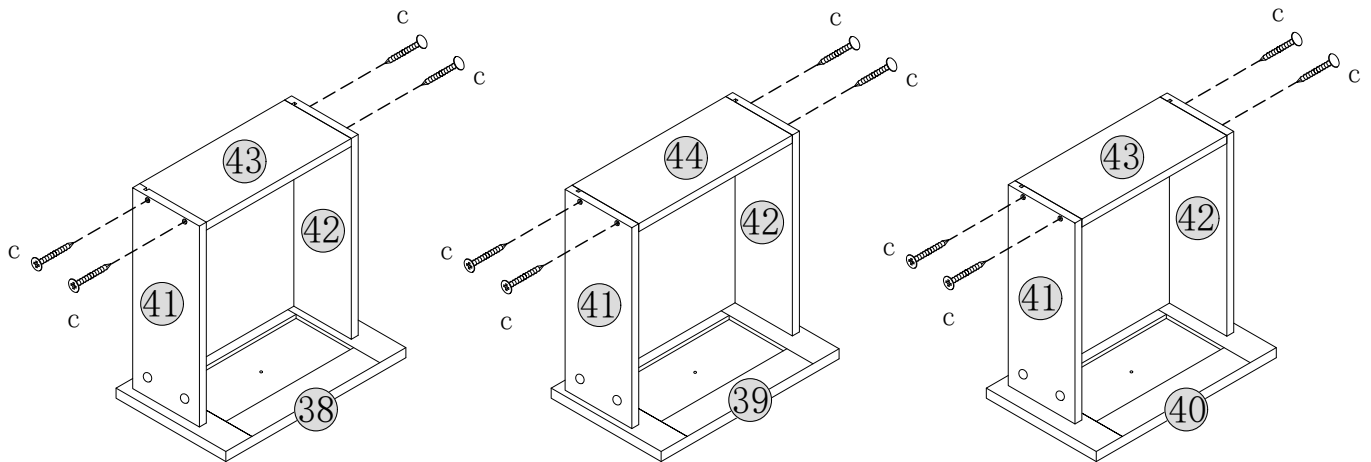

42

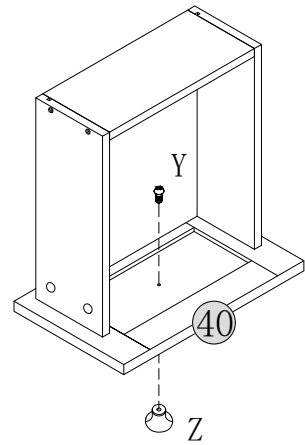
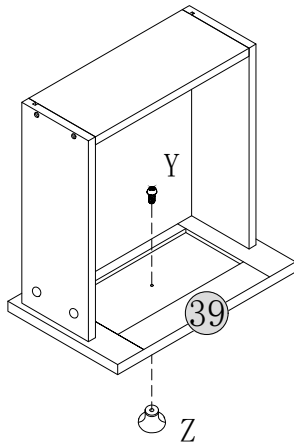
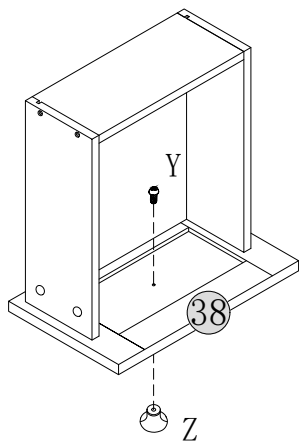

$c \times 12$

 $\phi 4 \times 30\text{mm}$



43

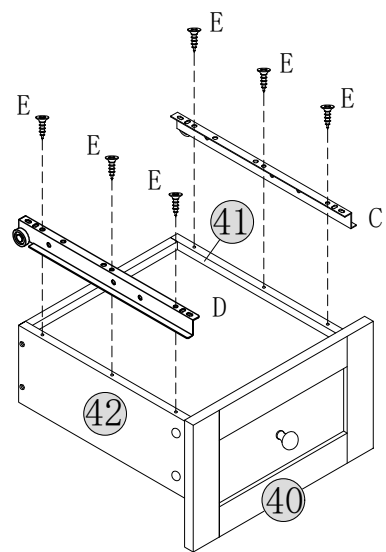
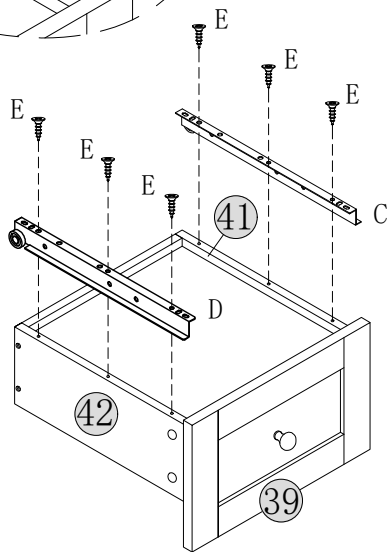
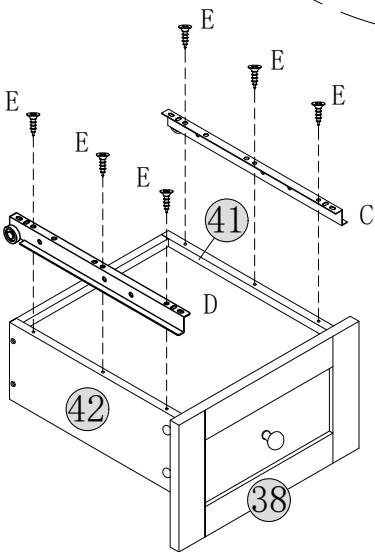
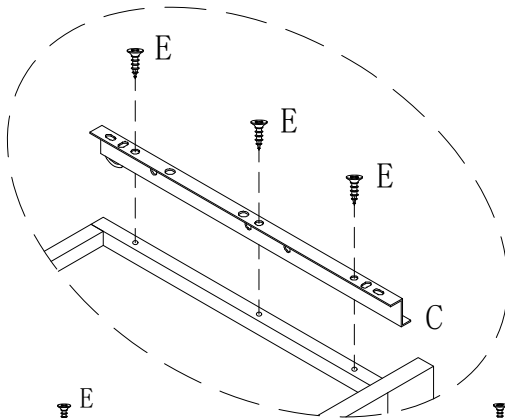

Y × 3	Z × 3
	
	Ø4 × 8mm

44

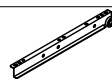
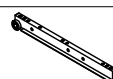

C × 3	D × 3	E × 18
		
L 300mm	L 300mm	Ø3 × 12mm

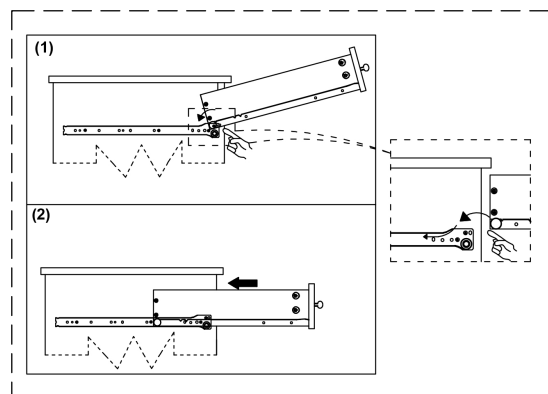
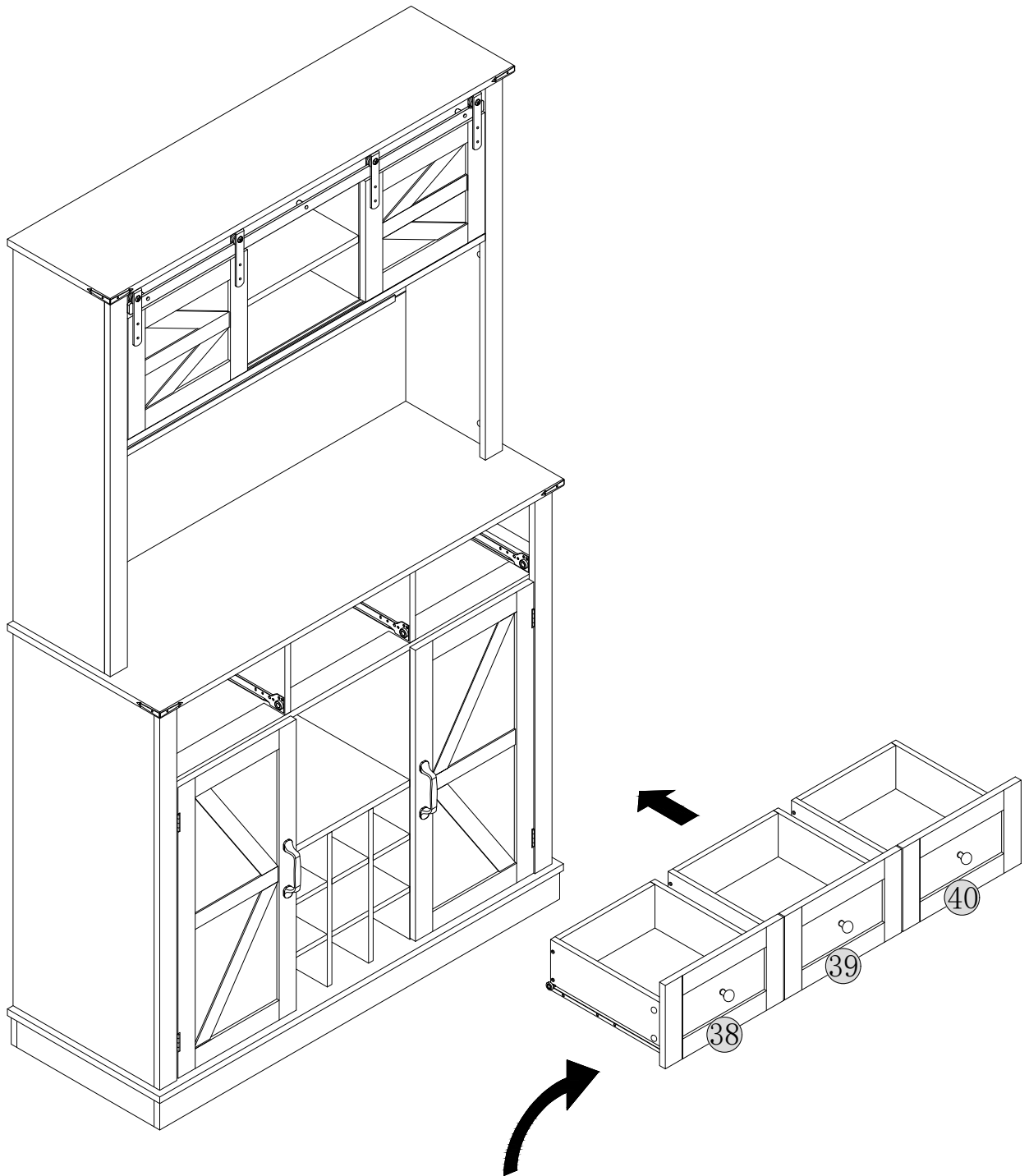

The wheels of the track have to be aligned and pushed along.

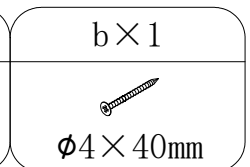
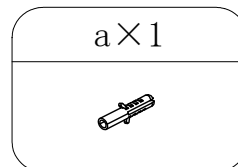
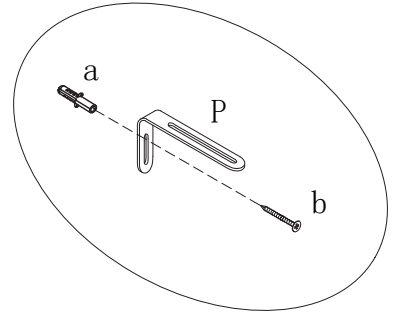
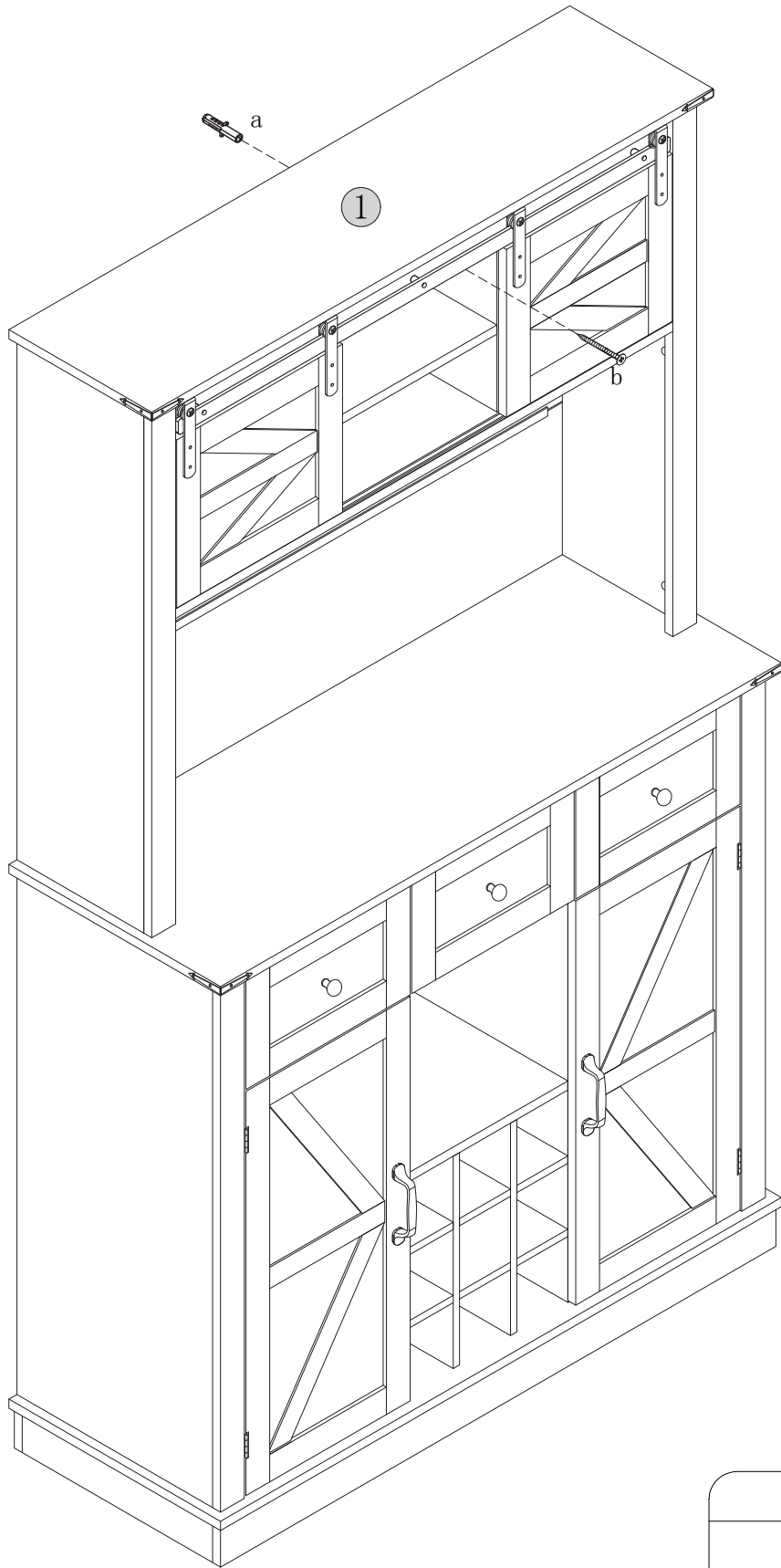

AFTER-SALE SERVICE

If you have any suggestions for our products or find that the products have quality problems, please contact us first, our after-sales team will reply you within 24 hours, and we will do our best to give you solutions until you are satisfied.

Guaranteed Customer Service

Your shopping experience is very important to us!
Feel unsatisfied? **Contact us!**
Have any questions? **Contact us!**

Wanna share your experience with our products?
Share your pictures with us.

Any suggestions? **Contact us!**
We gotcha back!