

# ASSEMBLY INSTRUCTIONS

## CARTER FULL BED

CRWN

(BOX 1) - BOX OF FULL BED

PARTS LIST				HARDWARE LIST			
NO.	DESCRIPTION	SKETCH	QTY	NO.	DESCRIPTION	SKETCH	QTY
1	HEADBOARD PANEL		1	A	JCBB ( M6 x 30mm ) W/FLAT WASHER & SPRING WASHER		8
2	HEADBOARD LEG ( L / R )		2	B	JCBB ( M8 x 40mm ) W/FLAT WASHER & SPRING WASHER		6
3	FOOTBOARD		1	C	JCBB ( M8 x 20mm ) W/FLAT WASHER		8
4	SIDE RAIL ( L / R )		4	D	ALLEN KEY (M4)		1
5	CENTER LEG		2	E	ALLEN KEY (M5)		1
6	DECKING BOARD		4	F	PANHEAD SCREW (M4 x 32mm)		9
7	SLAT		4	G	PANHEAD SCREW (M3.5 x 20mm)		16
8	CENTER RAIL		1	H	SCREW DRIVER (*)		1
9	VERTICAL LEG		4	*The manufacturer does not provide item H.			

### IMPORTANT NOTE :

- \* Place all wooden parts on a clean and smooth surface such as a rug or carpet to avoid the parts from being scratched.
- \* Check to be sure that you have all parts and hardware.
- \* Remove all wrapping materials, including staples & packing straps before you start to assemble.
- \* Do not tighten all screws/bolts until all completely assembled.
- \* Keep all hardware parts out of reach of children.

### STEP 4

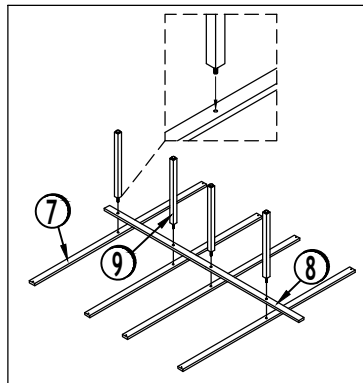

### STEP 1

BACK VIEW

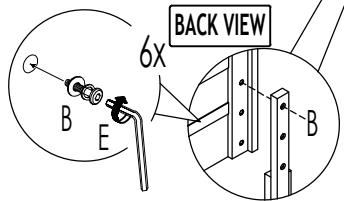

### STEP 3

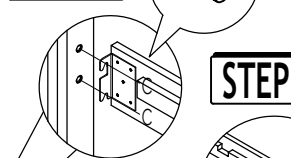

### STEP 2

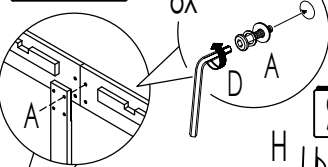

### STEP 5

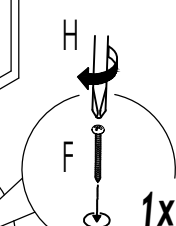
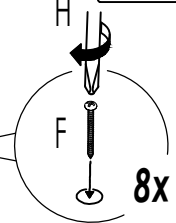

### STEP 6

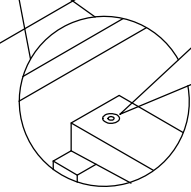

# ASSEMBLY INSTRUCTIONS





## CARTER FULL BED

CRWN

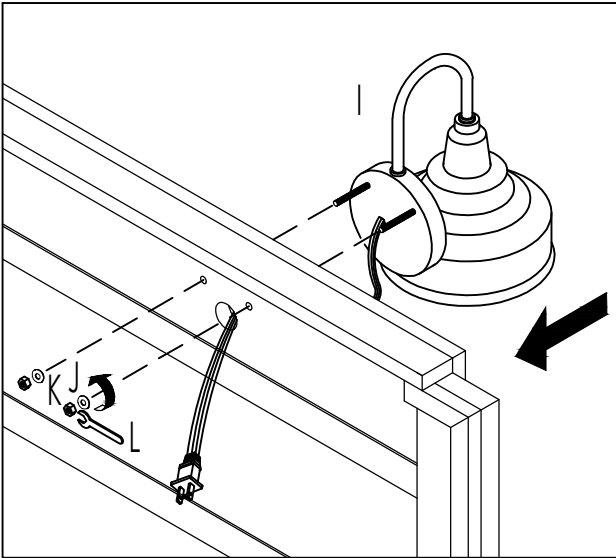
**STEP 8**

**BACK VIEW**



(BOX 2) - BOX OF LAMP			
HARDWARE LIST			
NO.	DESCRIPTION	SKETCH	QTY
I	LAMP		2
J	HEX NUT		4
K	FLAT WASHER		4
L	ALLEN WRENCH		2

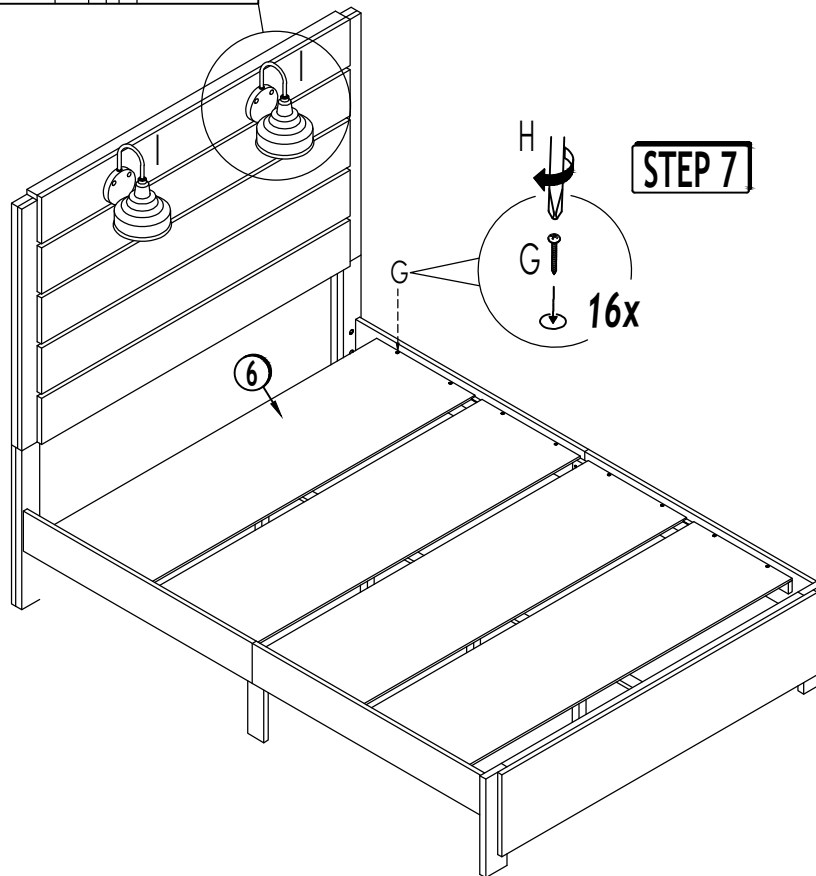

**STEP 7**

**COMPLETE**