

Assembly Instruction

00:15

Approx. 15 minutes



Recomm. 1 Person

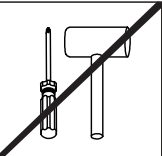

No Tools Required

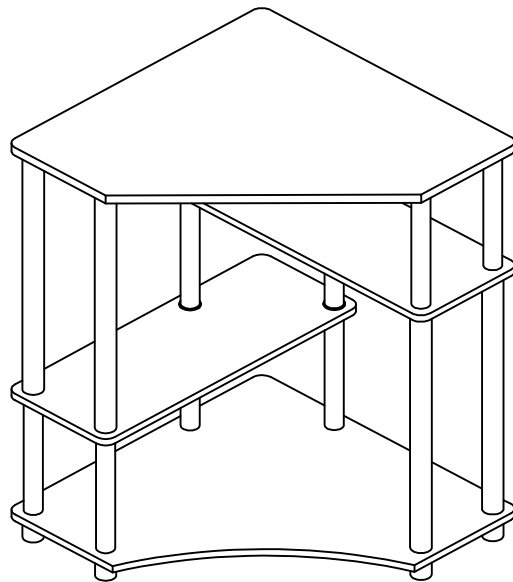

HARDWARE & PART LIST

NO	PARTS LIST	QTY	NO	HARDWARE	QTY
A	TOP PANEL	1pc	1	EXRTA LONG ROUND POLE	4pcs
B	BOTTOM PANEL	1pc	2	MEDIUM LONG POLE	10pcs
C	SHELF PANEL	2pcs	3	ROUND LEG	6pcs
			4	ROUND RING	8pcs

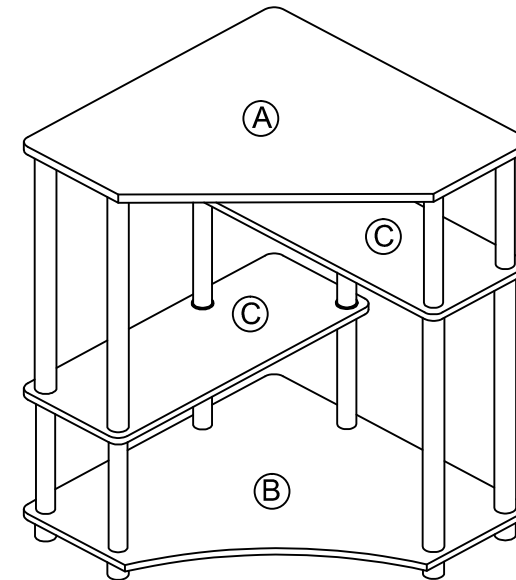

USEFUL HINTS BEFORE YOU START:

1. Read each step carefully before starting.
2. It is important that each step is performed in correct order to avoid difficulties.
3. Identify, sort and count the parts before assembly.
4. Assemble your furniture on packaging cardboard to prevent scratch or damage.
5. Clean the product with mild cleanser using soft damped cloth. Do not use harsh or abrasive cleanser.
6. Using incompatible hardware might cause damage to product.

ASSEMBLY INSTRUCTION

STEP 1

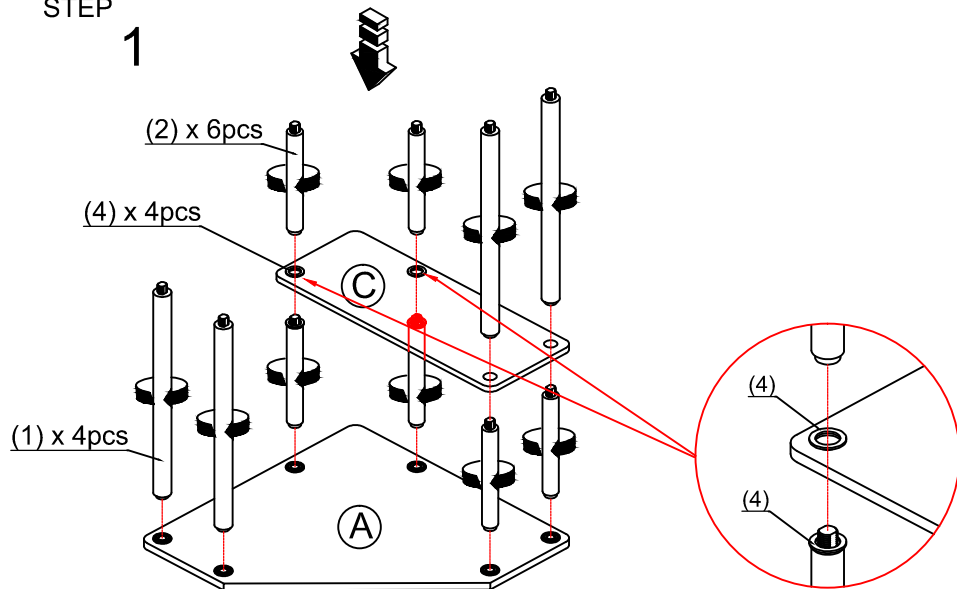

STEP 2

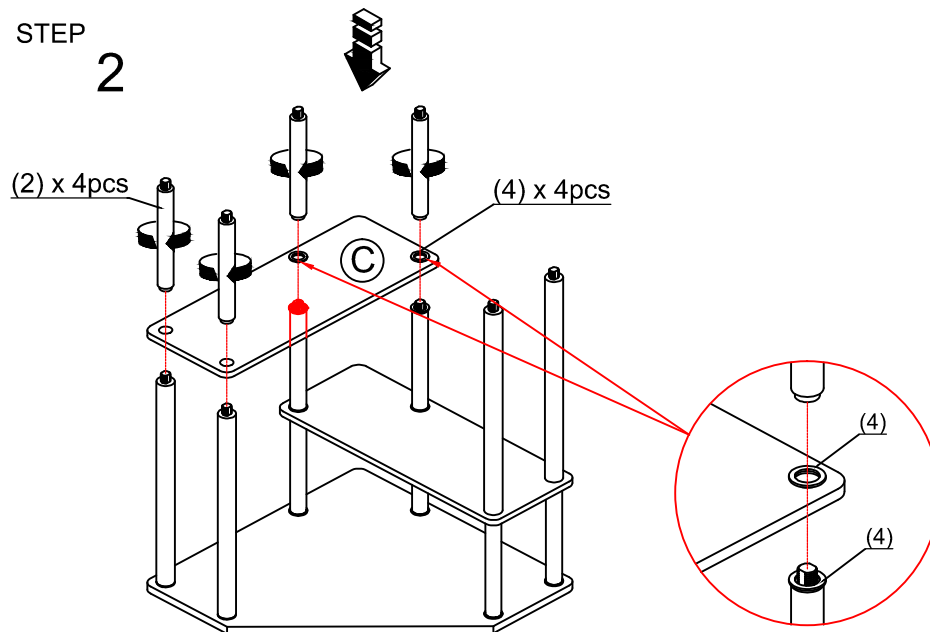

STEP 3

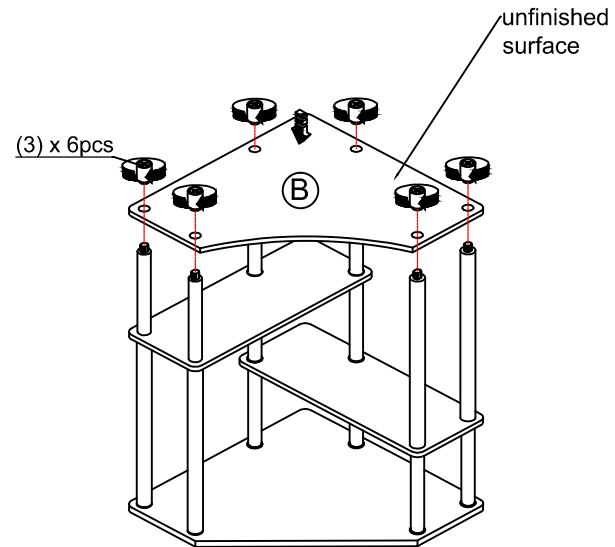

Recommended Maximum Weight

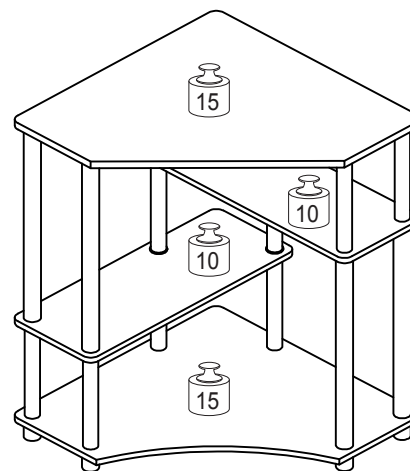

*Unit in Pound(lbs)

WARNING:

>This unit has been designed to support the maximum loads shown. Exceeding these load limits could cause sagging, instability, product collapse, and/or serious injury.

>DO NOT allow children to climb on unit.

>Put heavier items on lower shelves.