

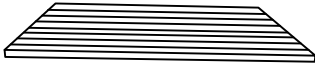

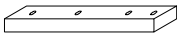

ASSEMBLY INSTRUCTION

A Table Top  1pc	B Connecting Support  4pcs	C Table Base  2pcs	D Bolt Ø5/16"x1-1/2"  16pcs
E Flat Washer Ø5/16"x22mm  16pcs	F Lock Washer Ø5/16"x13mm  16pcs	G Allen Key M5  1pc	

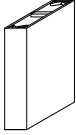

This page lists all the contents included in the box. Please take the time to identify the hardware as well as the individual components to this product. As you unpack and prepare for assembly, place the contents on a carpeted or padded area to protect them from damage.

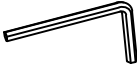
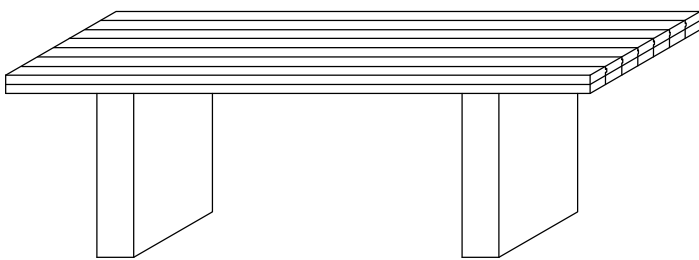
1 Attach Connecting Support (B) to Table Base (C) using Bolt (D), Flat Washer (E) and Lock Washer (F) by Allen Key (G) as below shown.

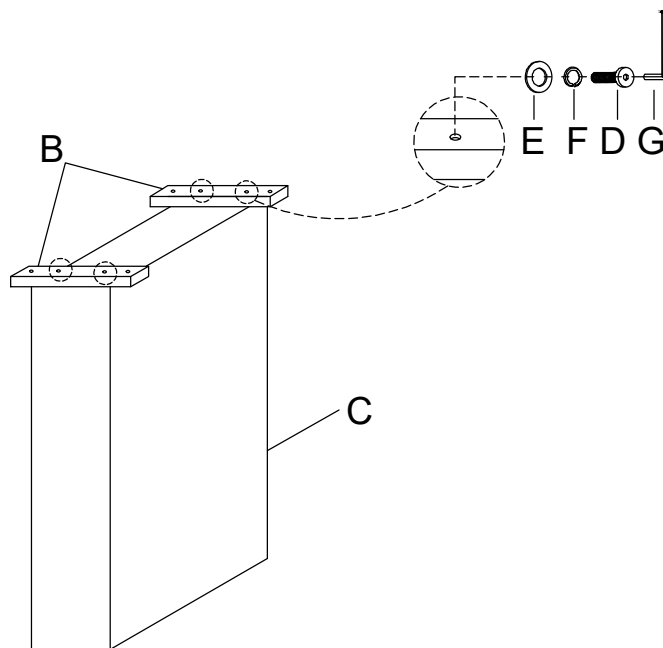

2 Attach Connecting Support (B) to Table Top (A) using Bolt (D), Flat Washer (E) and Lock Washer (F) by Allen Key (G) as below shown.

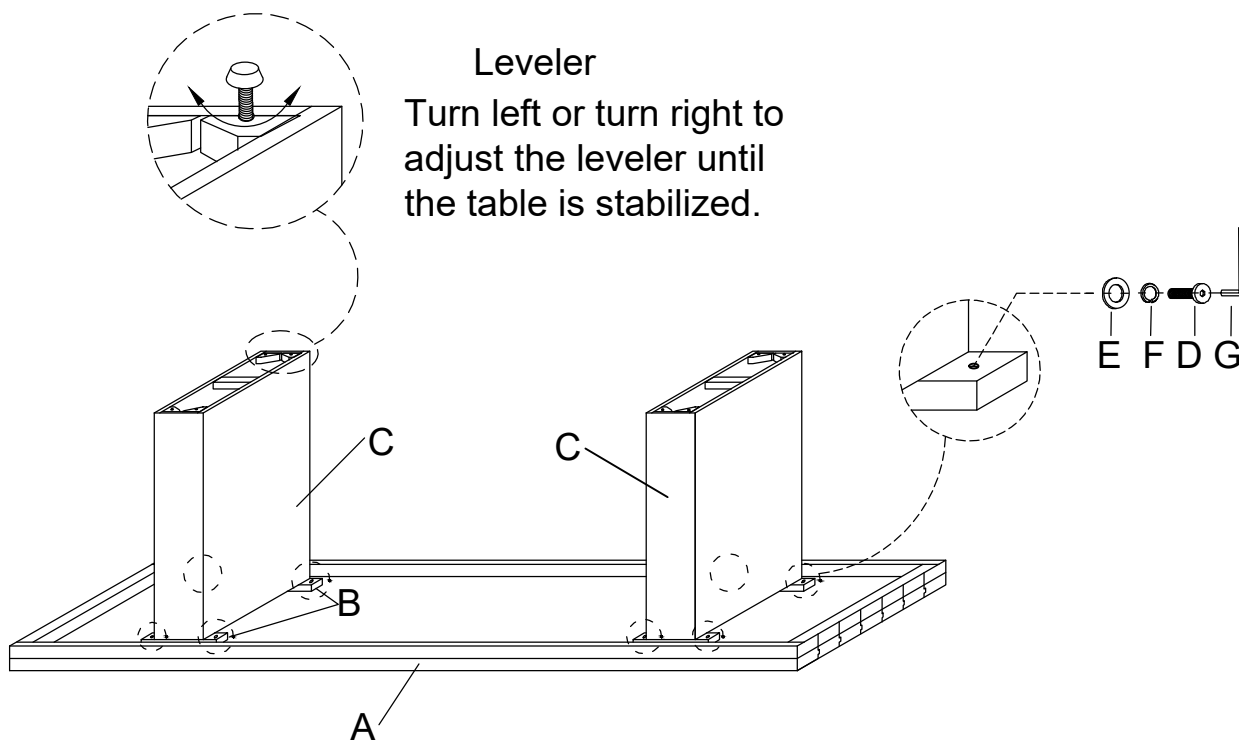

Cleaning & Care

Treat surface with care. Surface is resistant to scratches but is not scratch resistant. Clean surfaces with a dry or damp soft cloth. Do not use abrasive cleaners. Hardware may loosen over time. Periodically check that all connections are tight.

ASSEMBLY INSTRUCTION

A Chair Back **B** Left Leg **C** Right Leg **D** Seat **E** Center Cross Bar

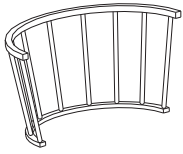

1 pc



1 pc

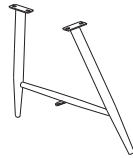

1 pc



1 pc



1 pc

F Bolt with Lock Washer and Flat Washer 1/4", 5/8" **G** Pan Head Bolt 1/4", 1-3/4" **H** Lock Washer Ø11 **I** Flat Washer Ø13 **J** Allen Wrench 4mm

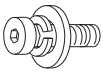

10 pcs



3 pcs



3 pcs



3 pcs

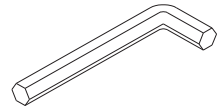

1 pc

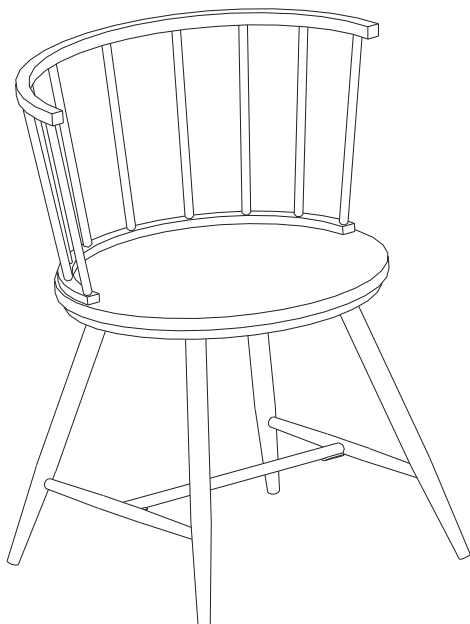

This page lists all the contents included in the box. Please take the time to identify the hardware as well as the individual components to this product. As you unpack and prepare for assembly, place the contents on a carpeted or padded area to protect them from damage.

- 1** Place and face down Seat (D) on a stable and smooth surface, attach Left Leg (B) and Right Leg (C) to the Seat (D) then tighten Bolt with Lock Washer and Flat Washer (F) with Allen Wrench (J).

Take the Allen Wrench, and turn the bolts until the legs are secure. **DO NOT TIGHTEN COMPLETELY.** Stop when you feel you are adding force to tighten the bolts.

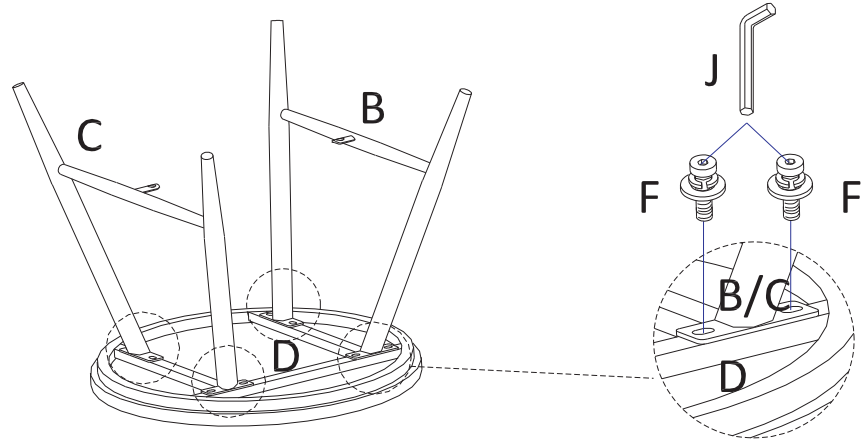

- 2** Align Center Cross Bar (E) to Left Leg (B) and Right Leg (C) then tighten Bolt with Lock Washer and Flat Washer (F) with Allen Wrench (J).

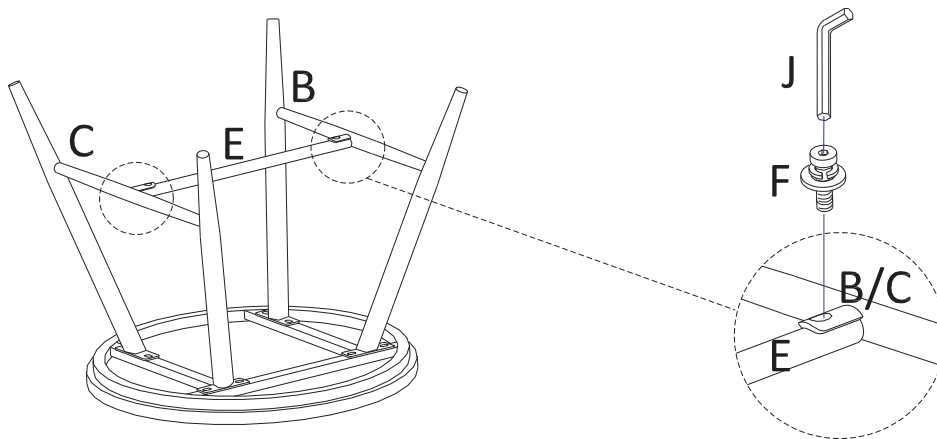

- 3** Place upright the assembled seat with legs, attach Chair Back (A) with Seat (D) then tighten with Pan Head Bolts (G), Lock Washer (H) and Flat Washer (I), using Allen Wrench (J).

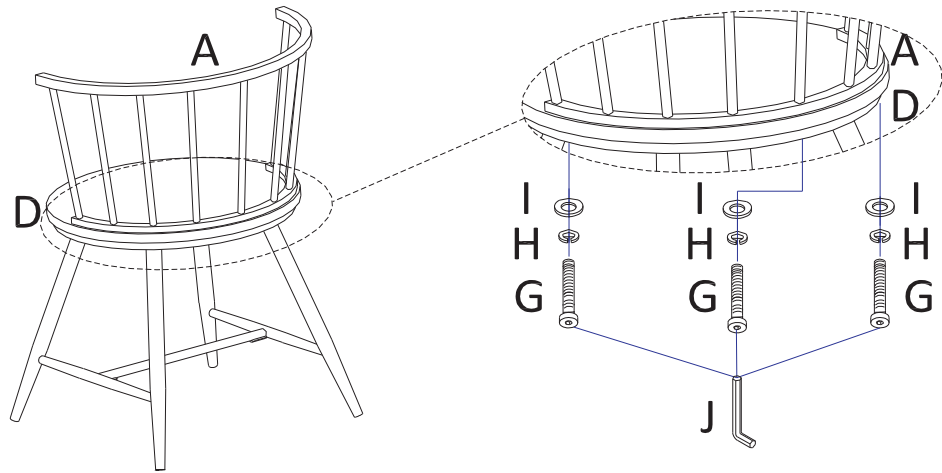

Helpful Tip:

-Instead of applying downward pressure while reaching under to tighten bolts, have someone sit in the chair while you tighten the bolts.

Stand chair up on an even surface and check that it is balanced. If there is a slight wobble, apply downward pressure in the corner where a leg is uneven. Keeping pressure in that corner, tighten all bolts.

If balanced, apply downward pressure evenly in the center and tighten all bolts.

Do not over-tighten beyond hole depth.

Cleaning & Care

Treat surface with care. Surface is resistant to scratches but is not scratch resistant. Clean surfaces with a dry or damp soft cloth. Do not use abrasive cleaners. Hardware may loosen over time. Periodically check that all connections are tight.