

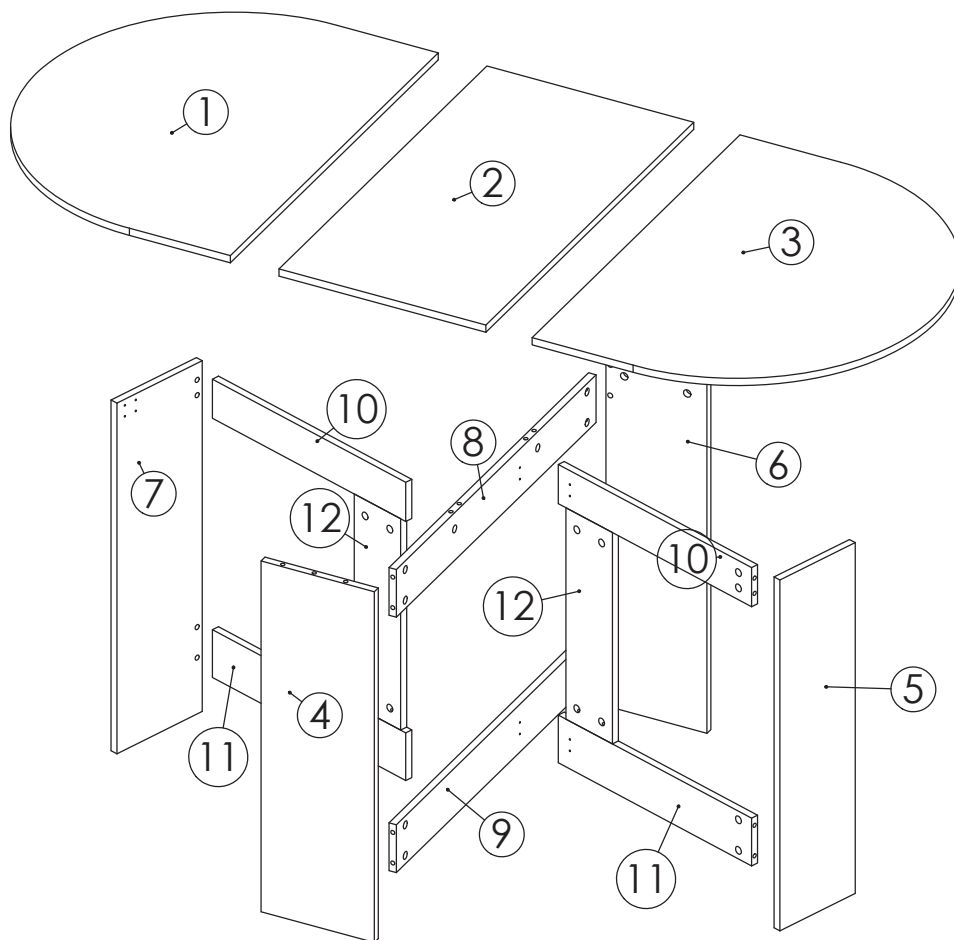







NO. Nr. N° NÚMERO N. Nr.	L L L LARGO Lunghezza Dł.	W B I ANCHO Larghezza Szer.	H H H ALTO Altezza Wys.	QTY. Menge Quantité CANTIDAD Quantità Ilość	NO. Nr. N° NÚMERO N. Nr.	L L L LARGO Lunghezza Dł.	W B I ANCHO Larghezza Szer.	H H H ALTO Altezza Wys.	QTY. Menge Quantité CANTIDAD Quantità Ilość
1	800 mm	605 mm	15 mm	1	7	735 mm	213 mm	15 mm	1
2	800 mm	420 mm	15 mm	1	8	768 mm	100 mm	15 mm	1
3	800 mm	605 mm	15 mm	1	9	768 mm	100 mm	15 mm	1
4	735 mm	230 mm	15 mm	1	10	500 mm	82 mm	15 mm	2
5	735 mm	188 mm	15 mm	1	11	500 mm	100 mm	15 mm	2
6	735 mm	205 mm	15 mm	1	12	443 mm	120 mm	15 mm	2



M6*40mm  A-30	 B-30	M8*40mm  C-8	M3.5*14mm  D-42
M3*16mm  E-8	 F-10	 G-2	 H-2

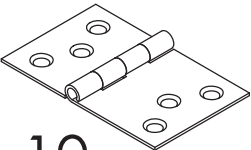
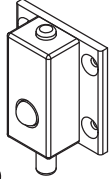

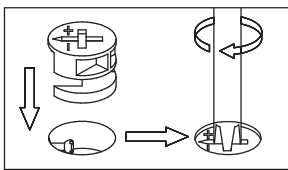
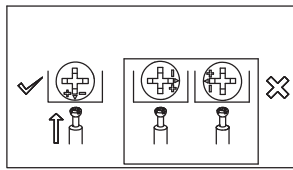
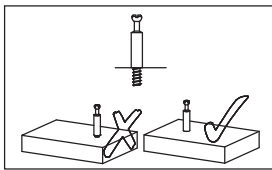
1

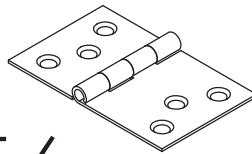

A-14 C-4 D-12 F-6

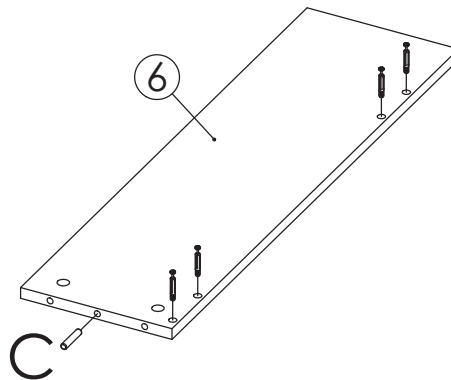
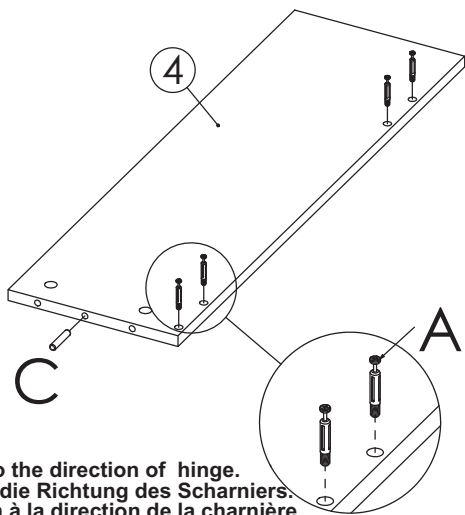

Pay attention to the direction of hinge.
 Achten Sie auf die Richtung des Scharniers.
 Faites attention à la direction de la charnière.
 Preste atención a la dirección de la bisagra.
 Prestare attenzione alla direzione della cerniera.
 Zwróć uwagę na kierunek zawiasu.

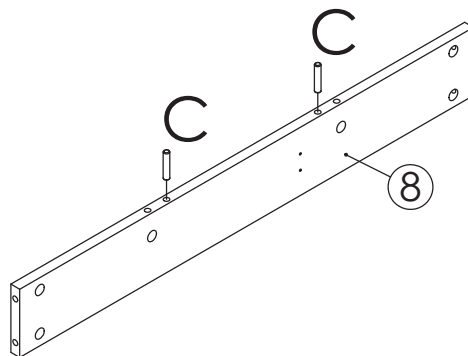
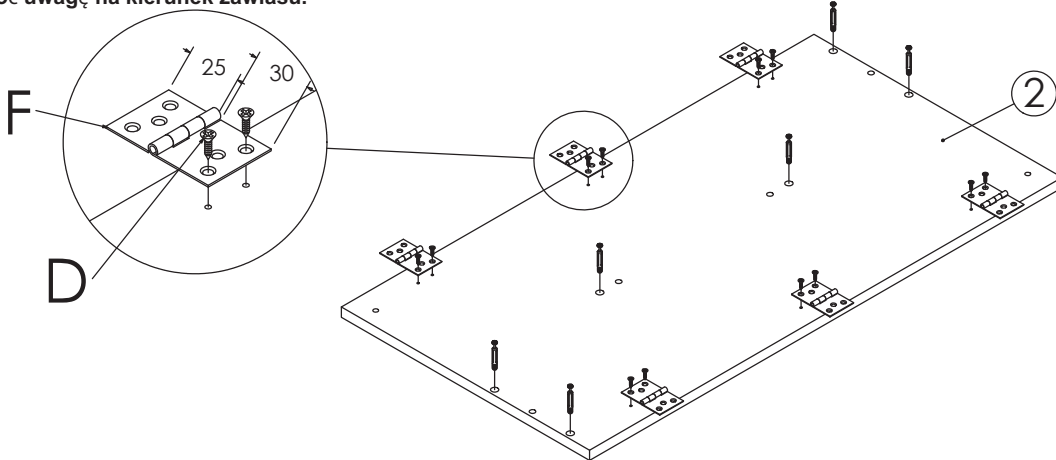

2



B-14

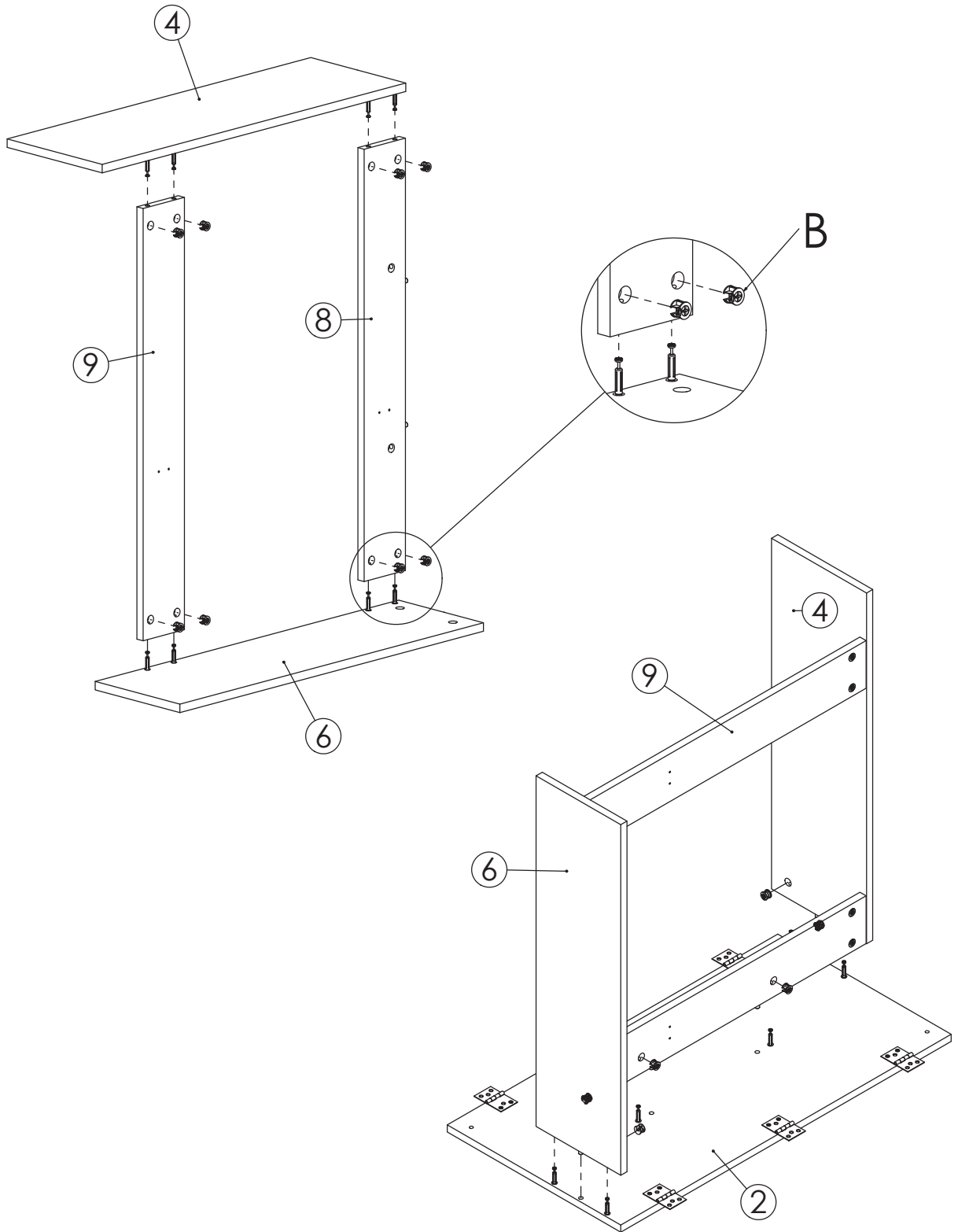

3



A-8



B-8



C-4



D-8

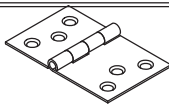

F-4

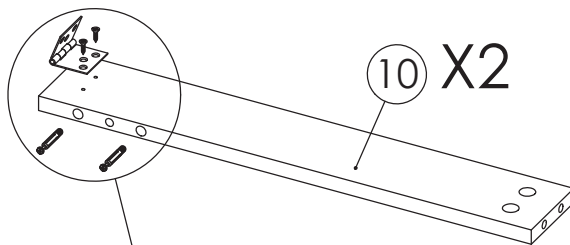

10 X2

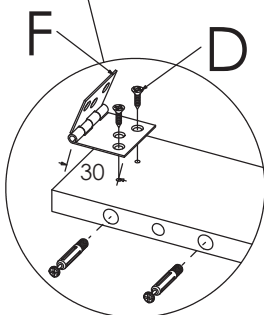

F

D

30

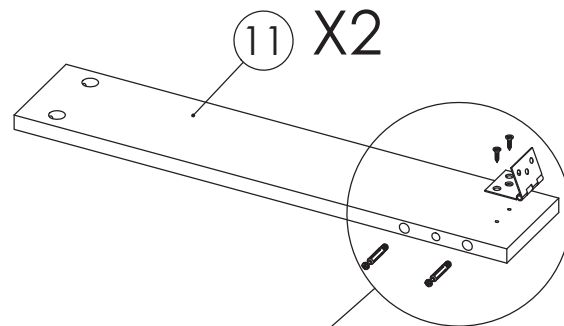

11 X2

Pay attention to the direction of hinge.
Achten Sie auf die Richtung des Scharniers.
Faites attention à la direction de la charnière.
Preste atención a la dirección de la bisagra.
Prestare attenzione alla direzione della cerniera.
Zwróć uwagę na kierunek zawiasu.

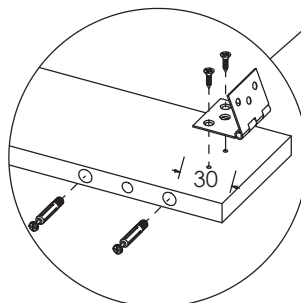

30

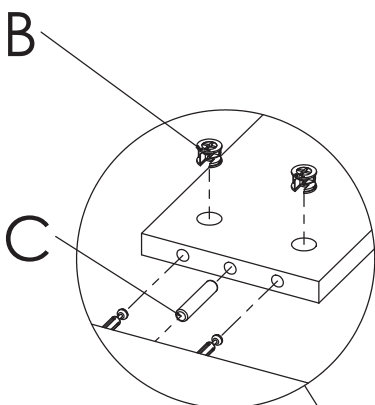

B

C

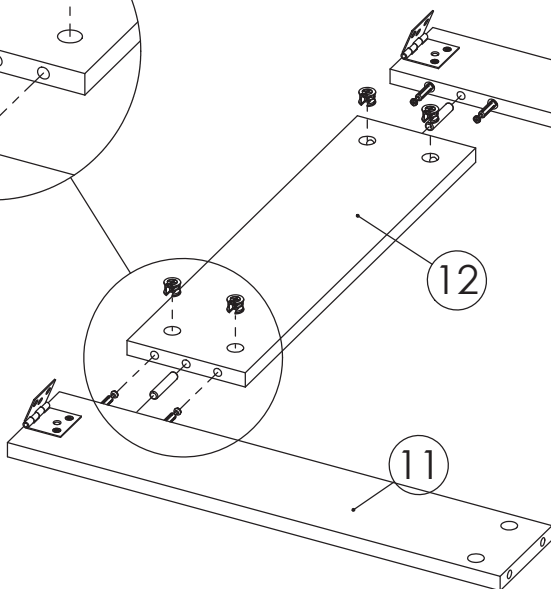

12

11

10

x2

4



A-8



B-8



E-8

G-2

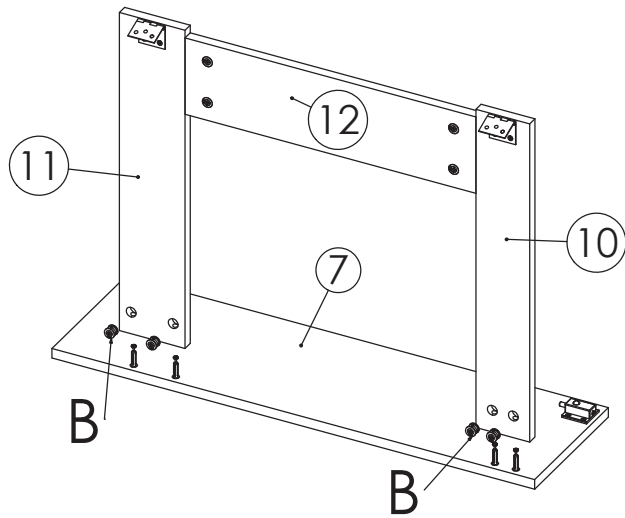
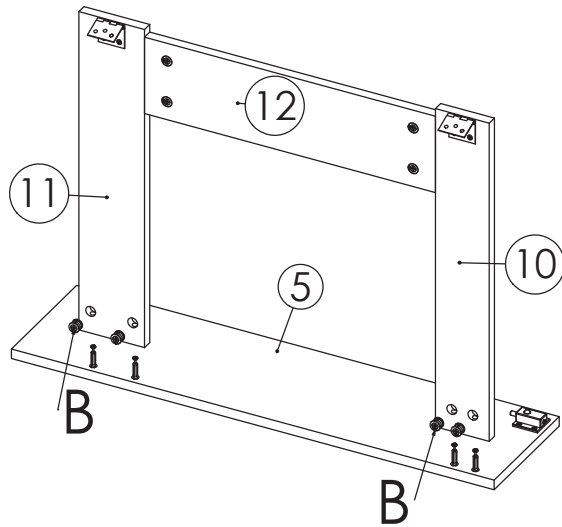
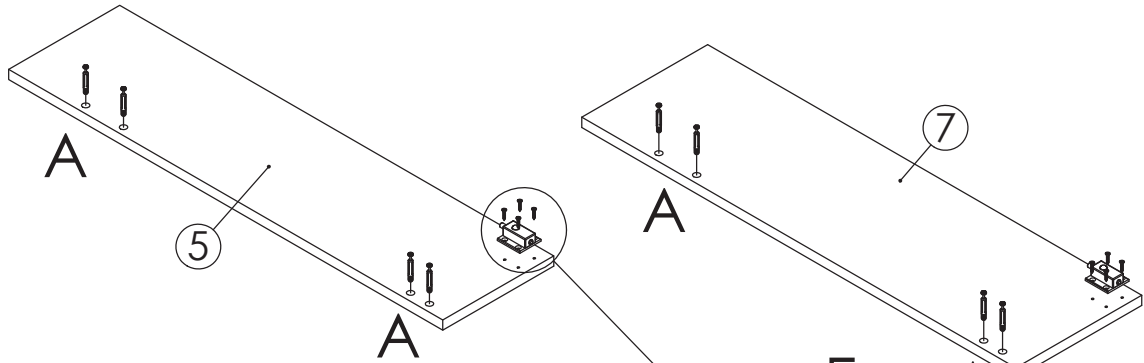
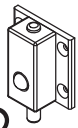

4



D-12

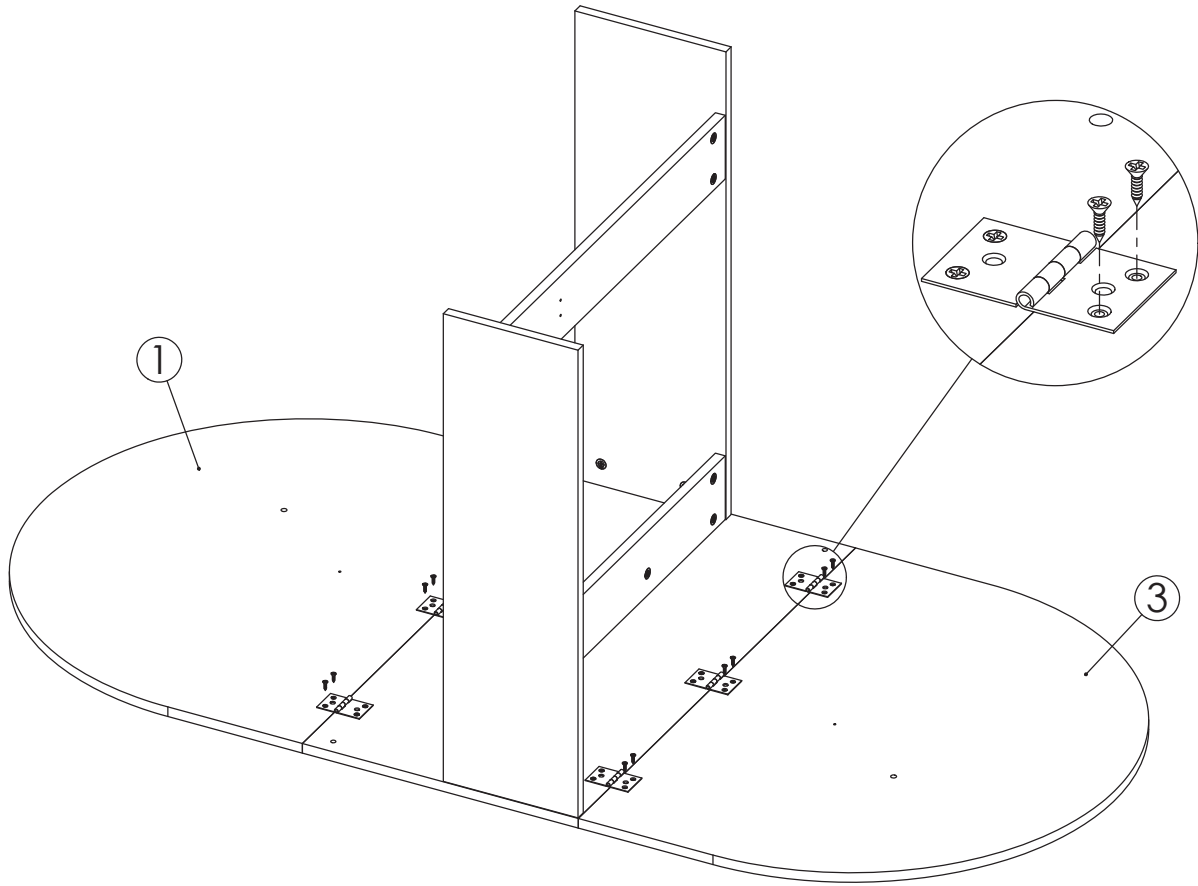

5



D-5



H-1

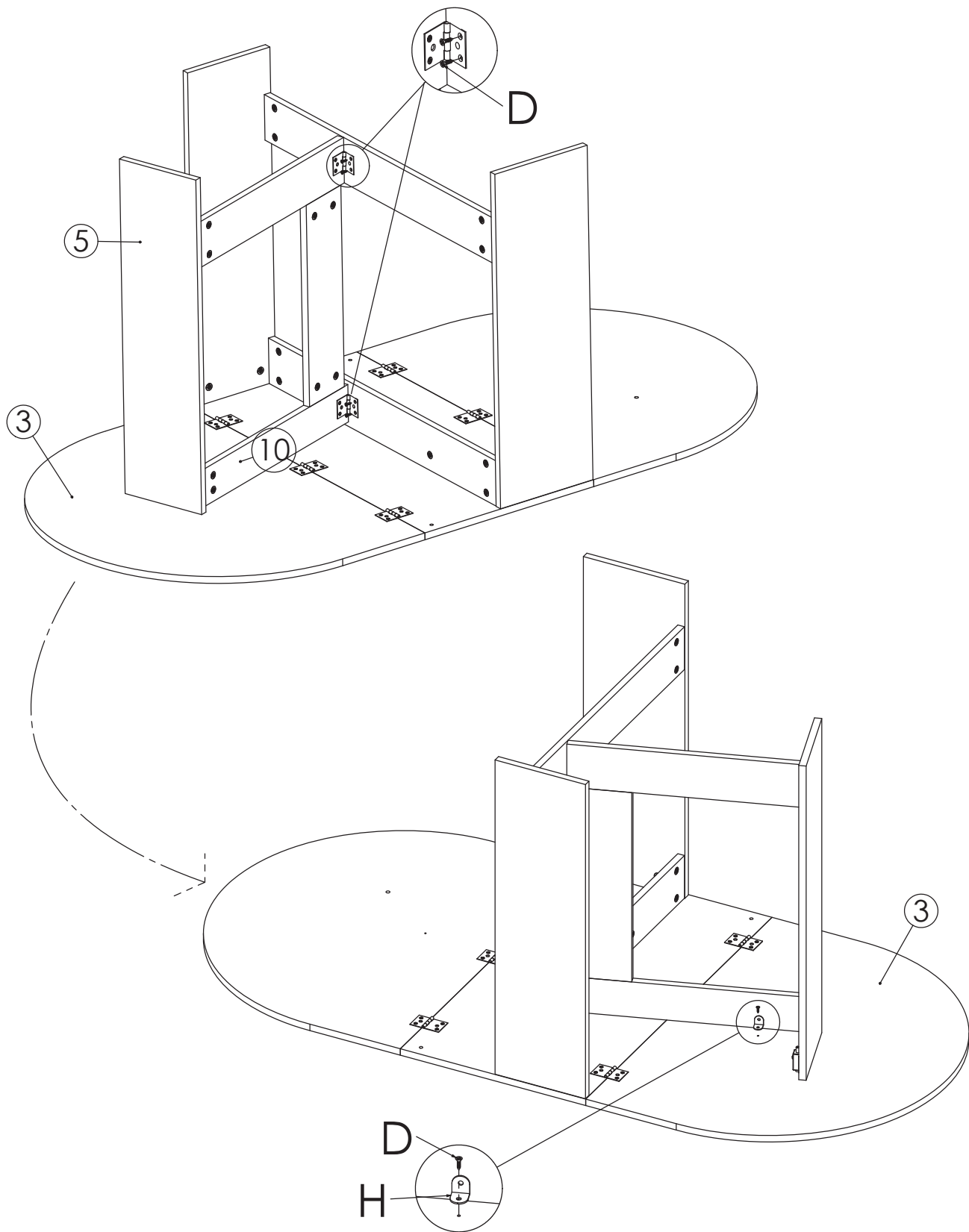

6



D-5



H-1

