

BAR TABLE ASSEMBLY MANUAL









Assembly Instructions

- Prior to assembly, ensure that you lay out and identify all the parts listed in the parts list.
- Tighten all nuts and bolts securely. Hand-tighten all bolts before use. Avoid using power tools or applying excessive force during assembly and bolt tightening.
- If you encounter any difficulties during assembly or if any part is missing or damaged

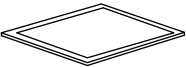
Care and warranty

- The weight capacity of this table is 50 lbs.
- Clean the frame components with a mild soap solution, then rinse thoroughly. Avoid using bleach, acid, or any other solvents on either the fabric or frame components.
- For a comprehensive warranty policy, Be aware that warranty terms can change without prior notification.
- For the best performance and safety of your table, inspect and tighten all bolts and fasteners regularly

Part list

Part	Description	Qty
A	 Top A diamond-shaped top plate with a double-line border.	1
B	 Leg A curved metal leg with a small hole at the top and a hook at the bottom.	4
C	 Leg Connector A diamond-shaped metal connector with a hole in the center.	1
D	 Holder A diamond-shaped metal holder with a grid pattern.	1
E	 M6*25 Screws A long screw with a hexagonal head.	16
F	 Washer A flat, circular washer with a hole in the center.	16
G	 Allen key An L-shaped hexagonal Allen key.	1

1. Connect the top (Part A) and legs (Part B) using Screws (E) and Washers (F) as illustrated in the diagram.

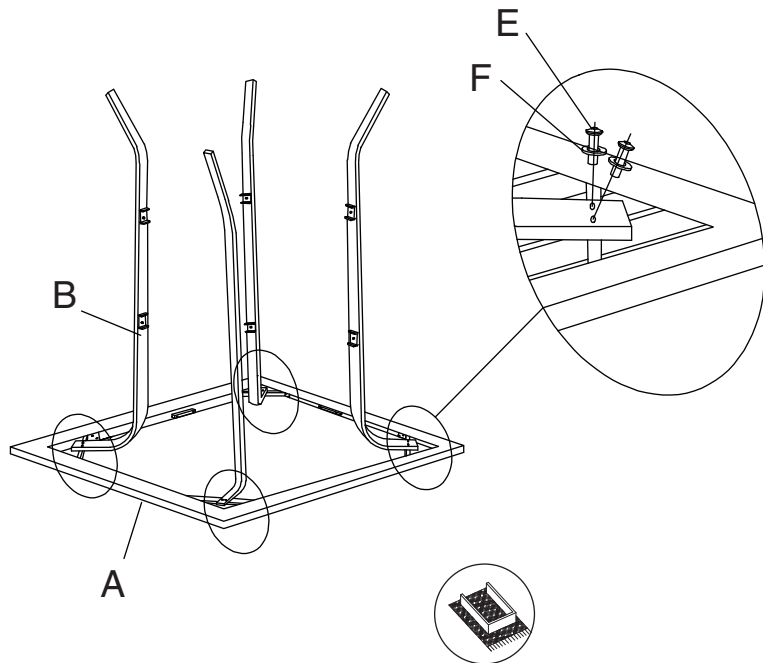

Reminder: All parts must be put on the carpet in the assembly.

2. Connect the leg connector (Part C) with the legs (Part B) using screws (E) and washer (F) as indicated in the diagram.

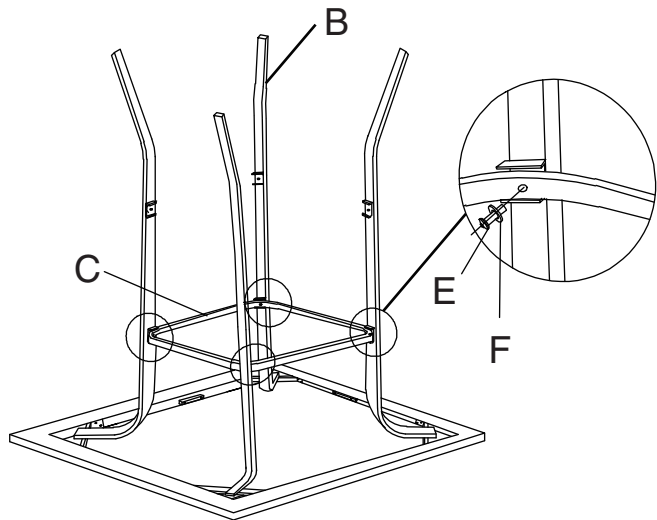

3. Connect the holder (Part D) to the legs (Part B) using screws (E) and washer (F) as shown in the diagram.

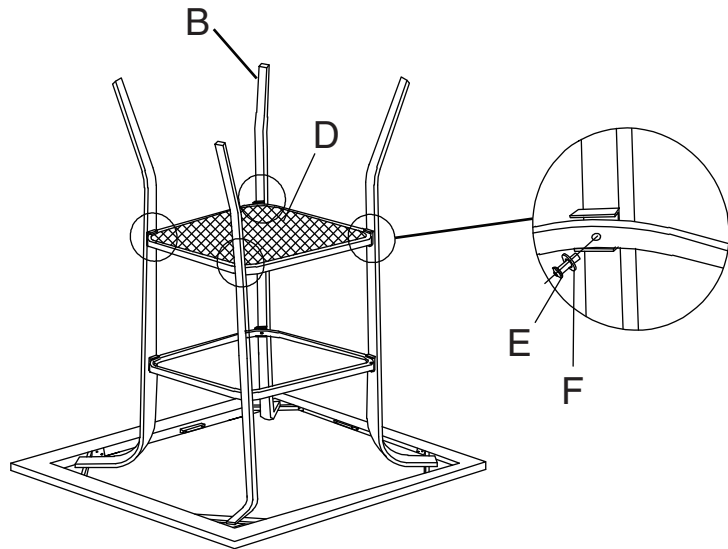

4. Finally, ensure that all screws are securely tightened before using the product on level ground.

