

CAUTION:When tightening the screws,tighten sequentially.Do not tighten any screws fully and then towards the next one.When every part is OK, then tighten all the screws.

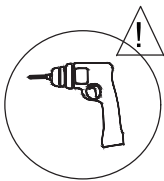

PLEASE BE CAREFUL DO NOT DAMAGE THE HOLE POSITION WHEN YOU USE POWER TOOLS !

If there are any missing parts, please contact us and we will send you the corresponding replacement part. We also offer an exclusive one-month service where we provide product replacements without the need for repairs, as long as the damage is not caused by human error.

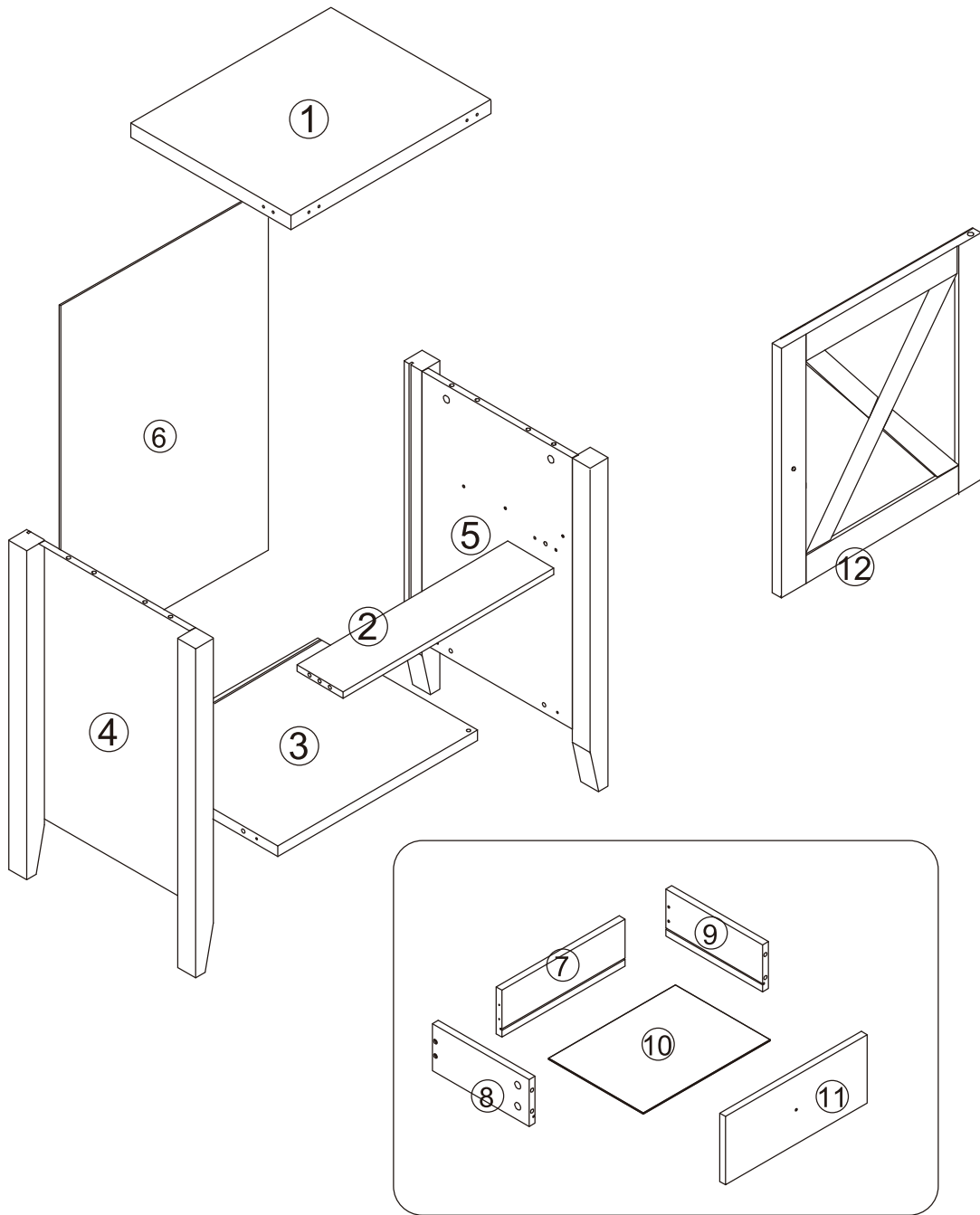

① x1

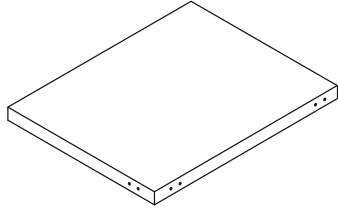

② x1

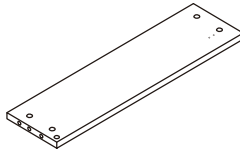

③ x1

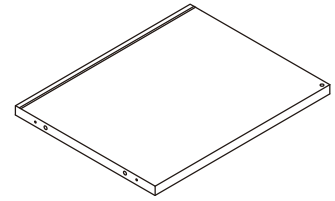

④ x1

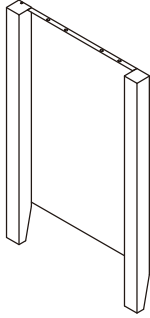

⑤ x1

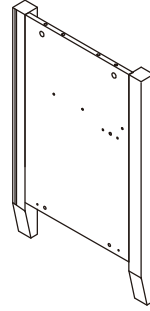

⑥ x1



⑦ x1

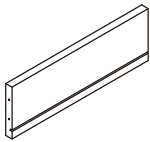

⑧ x1

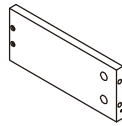

⑨ x1

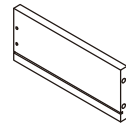

⑩ x1

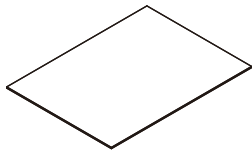



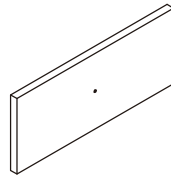



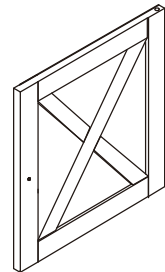

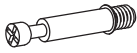













⑪ x1

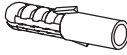

⑫ x1



<p>A X16(+1)</p>  <p>Ø6x35mm</p>	<p>B X16(+1)</p>  <p>Ø15x10mm</p>	<p>C X10(+1)</p>  <p>Ø6x30mm</p>	<p>D X6</p>  <p>Ø4x35mm</p>	<p>E X2</p>  <p>Ø3x12mm</p>
<p>F X4</p> 	<p>G X17(+1)</p>  <p>Ø3.5x12mm</p>	<p>H X2</p> 	<p>I X2</p> 	<p>J X1</p> 
<p>K X1</p> 	<p>L X2</p> 	<p>M X8</p> 	<p>N X2</p> 	<p>O X4</p> 
<p>P X2</p> 	<p>Q X2</p>  <p>Ø6x30mm</p>	<p>R X2</p> 		
<p>CL X1</p> 	<p>CR X1</p> 	<p>DL X1</p> 	<p>DR X1</p> 	

## SPECIAL TIPS FOR FITTING CAM-LOCKS AND QUICKFIT

WHEN FITTING CAMLOCK  
ENSURE STARTING POSITION IS CORRECT  
BEFORE YOU INSERT CONNECTING QUICKFIT  
TURN CLOCKWISE UNTIL SECURE



### CAM-LOCK

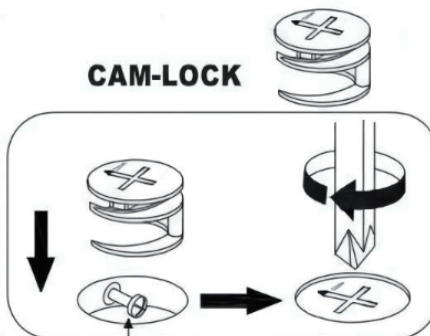

Quickfit head needs to be in centre

### QUICKFIT

Tighten until shoulder is flush with panel. DO not overtighten or undertighten (see example below)

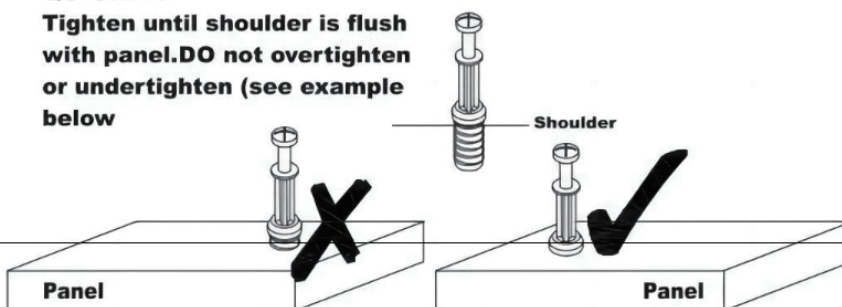

**1** When linking part CR with part5, pay attention to the first 3mm small hole on the right side, and install it according to the instructions

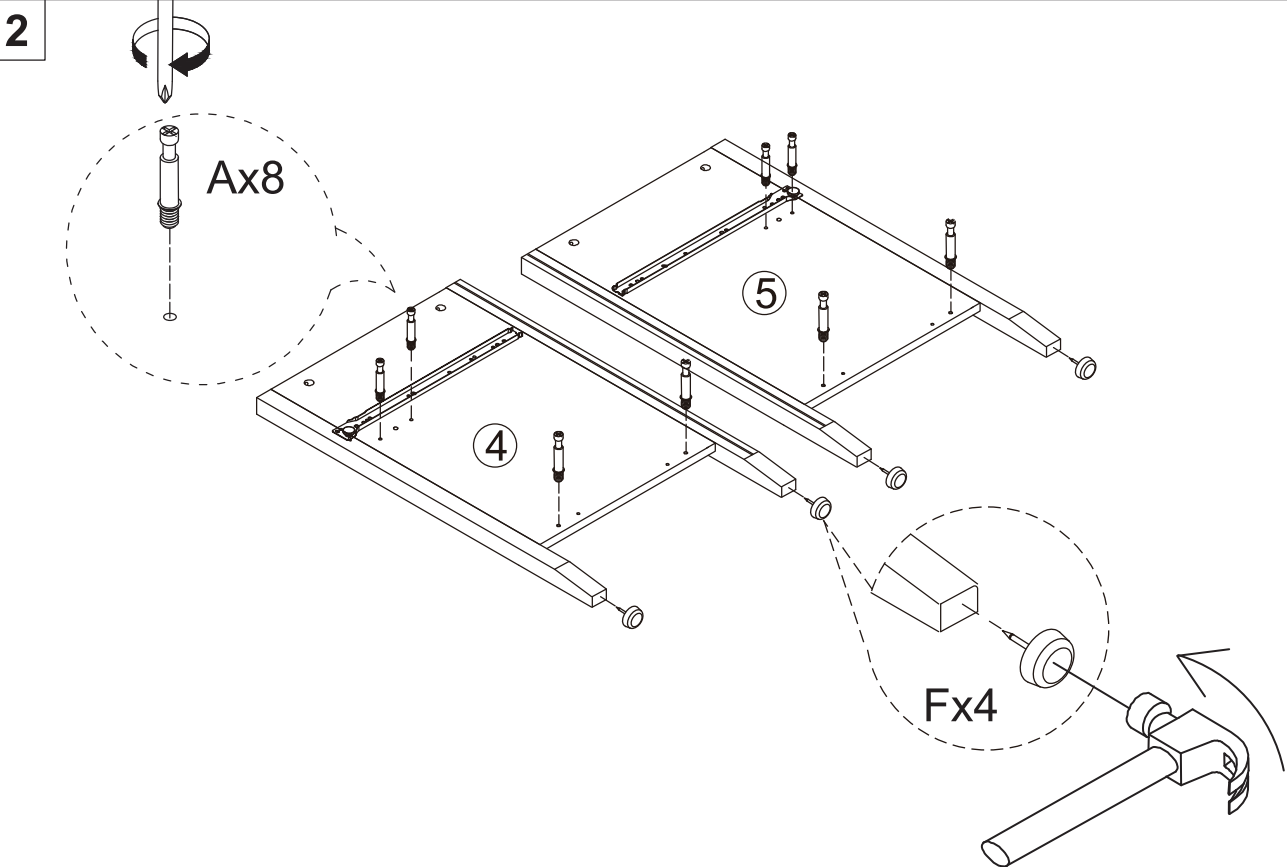
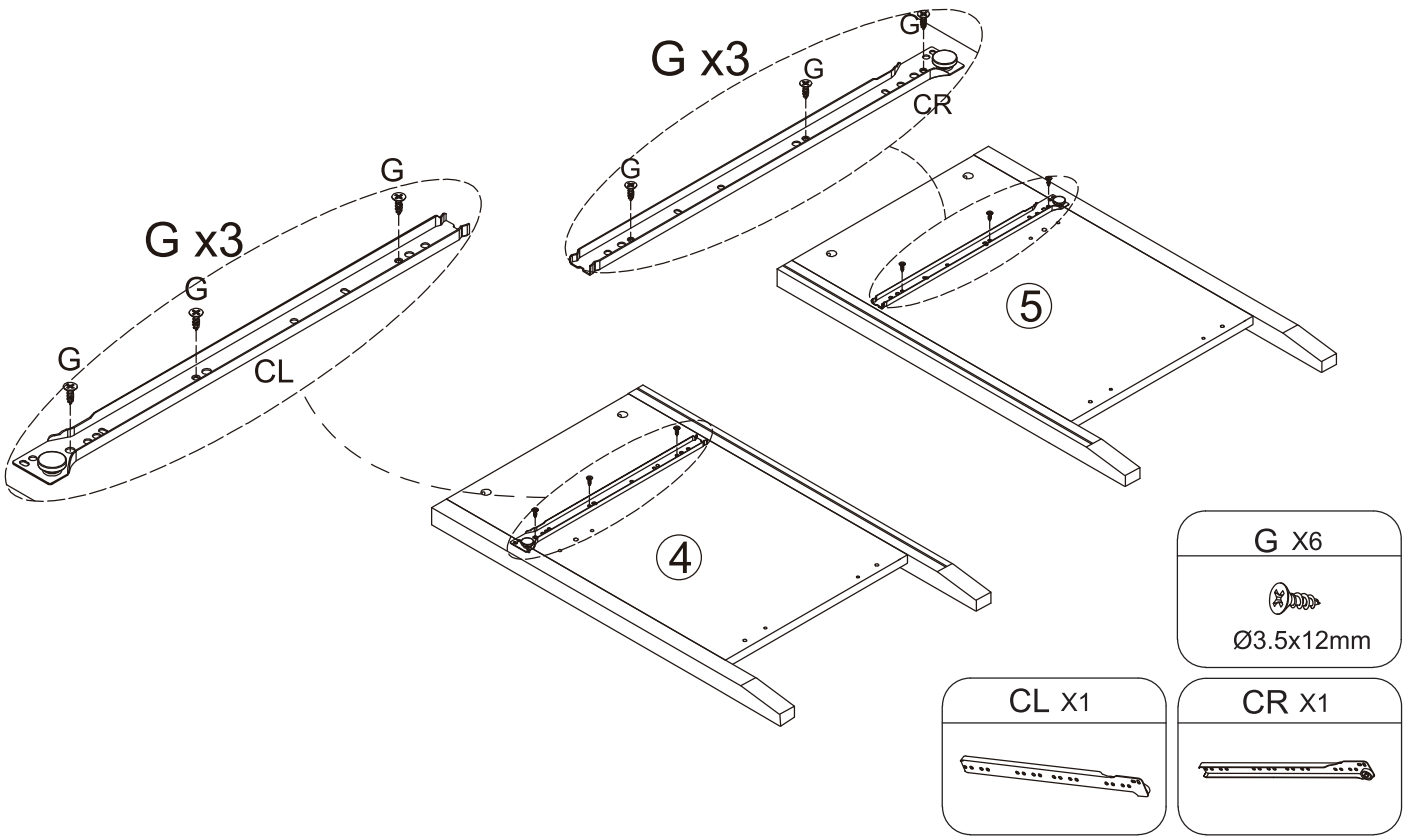

3

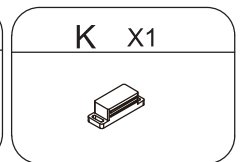
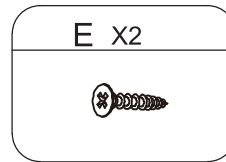
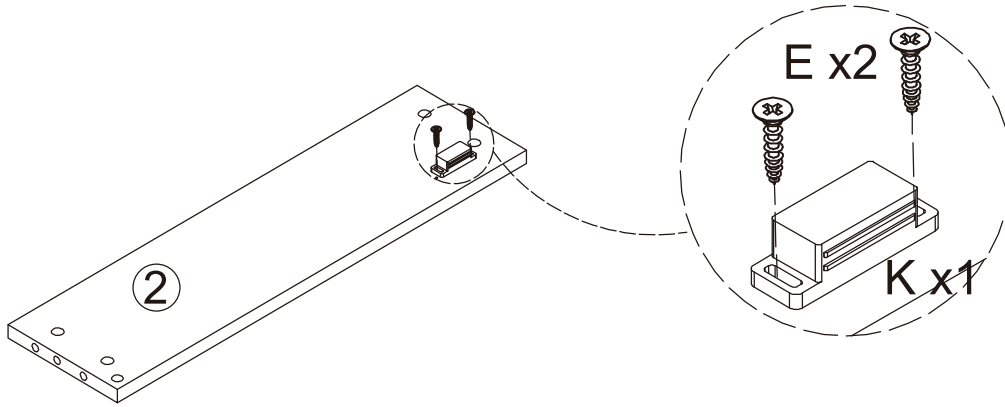

4

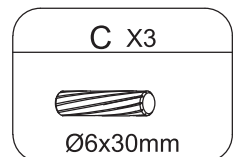
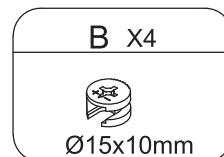
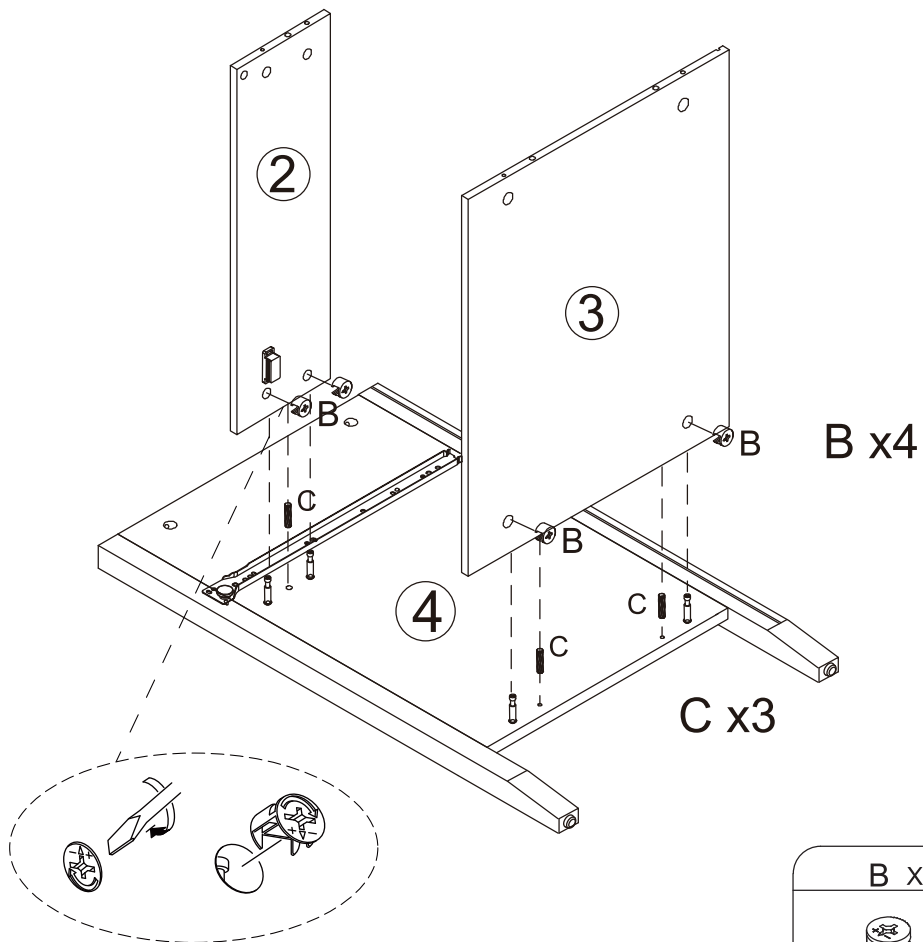

5

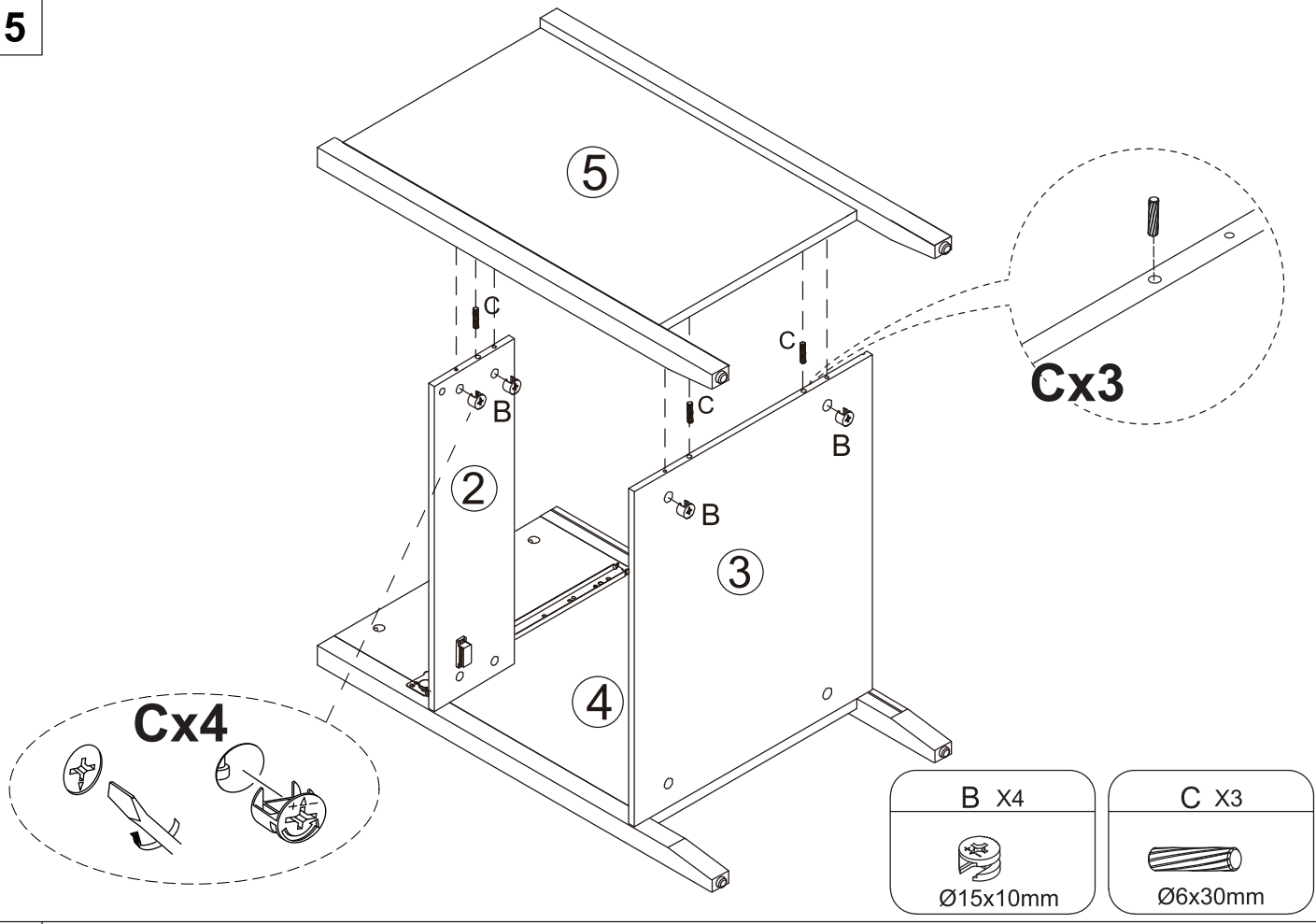

6

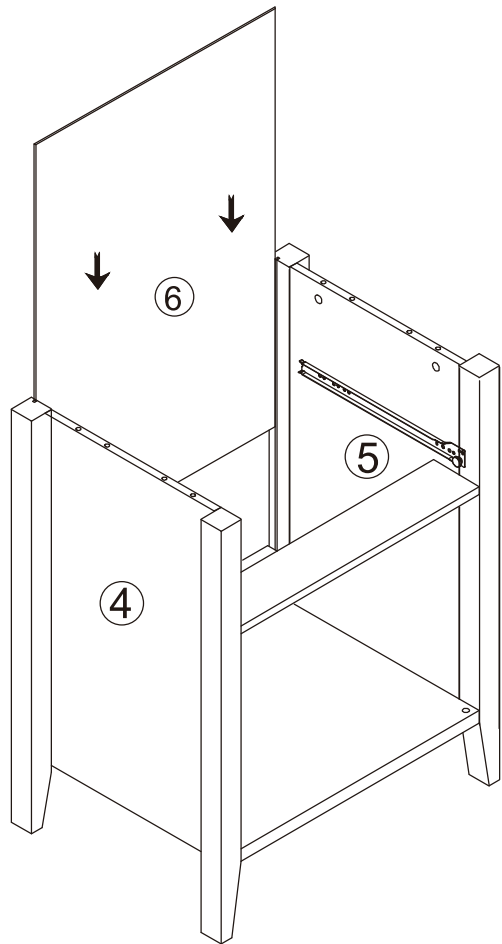

7

7

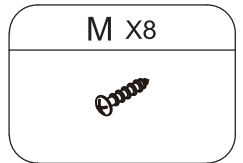
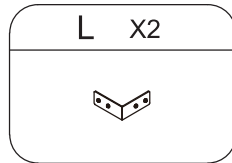
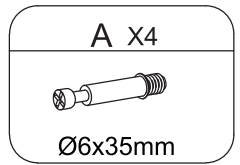
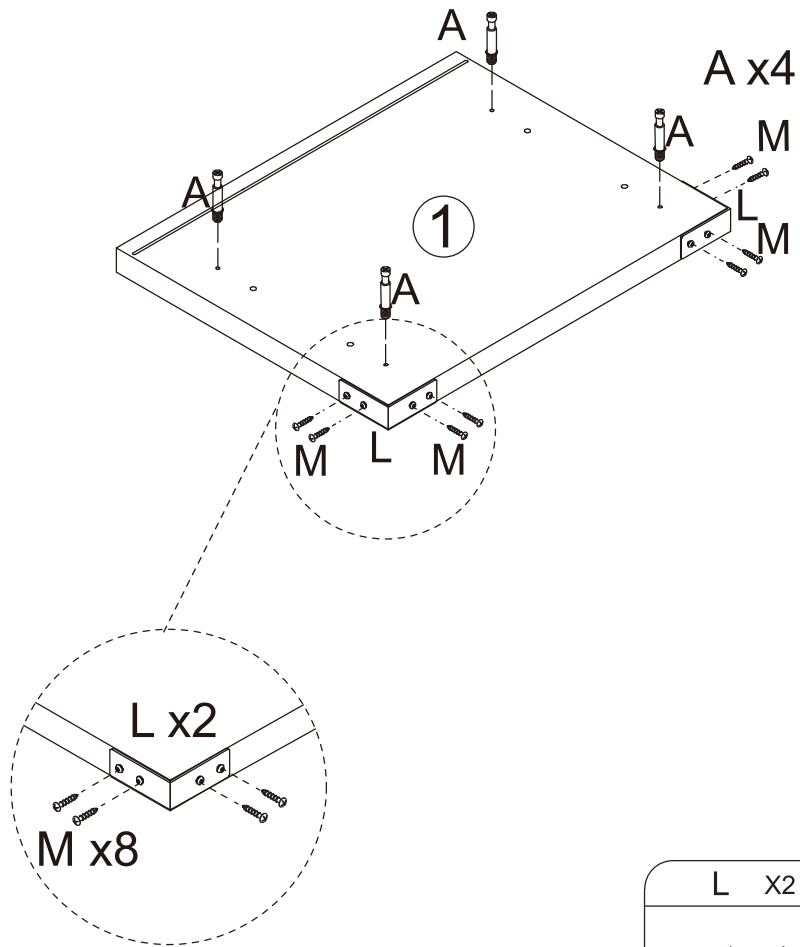

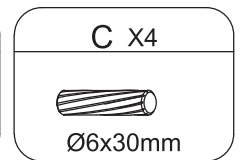
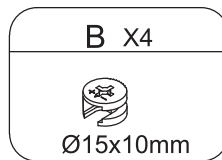
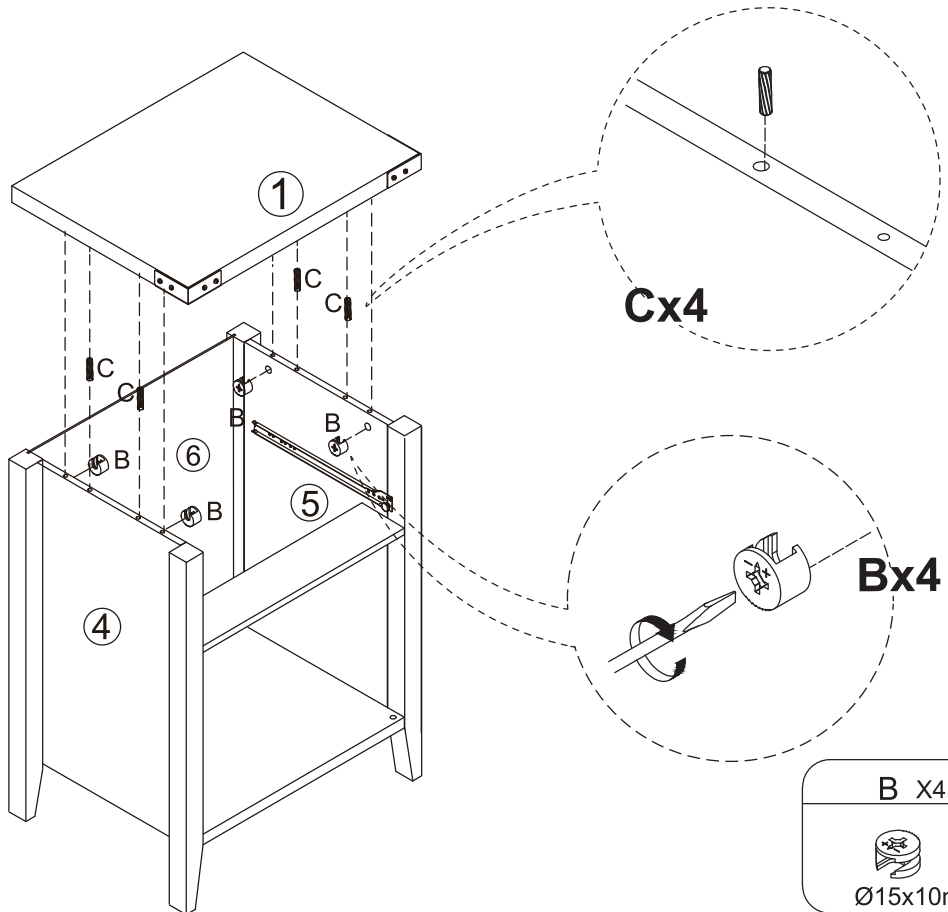

8

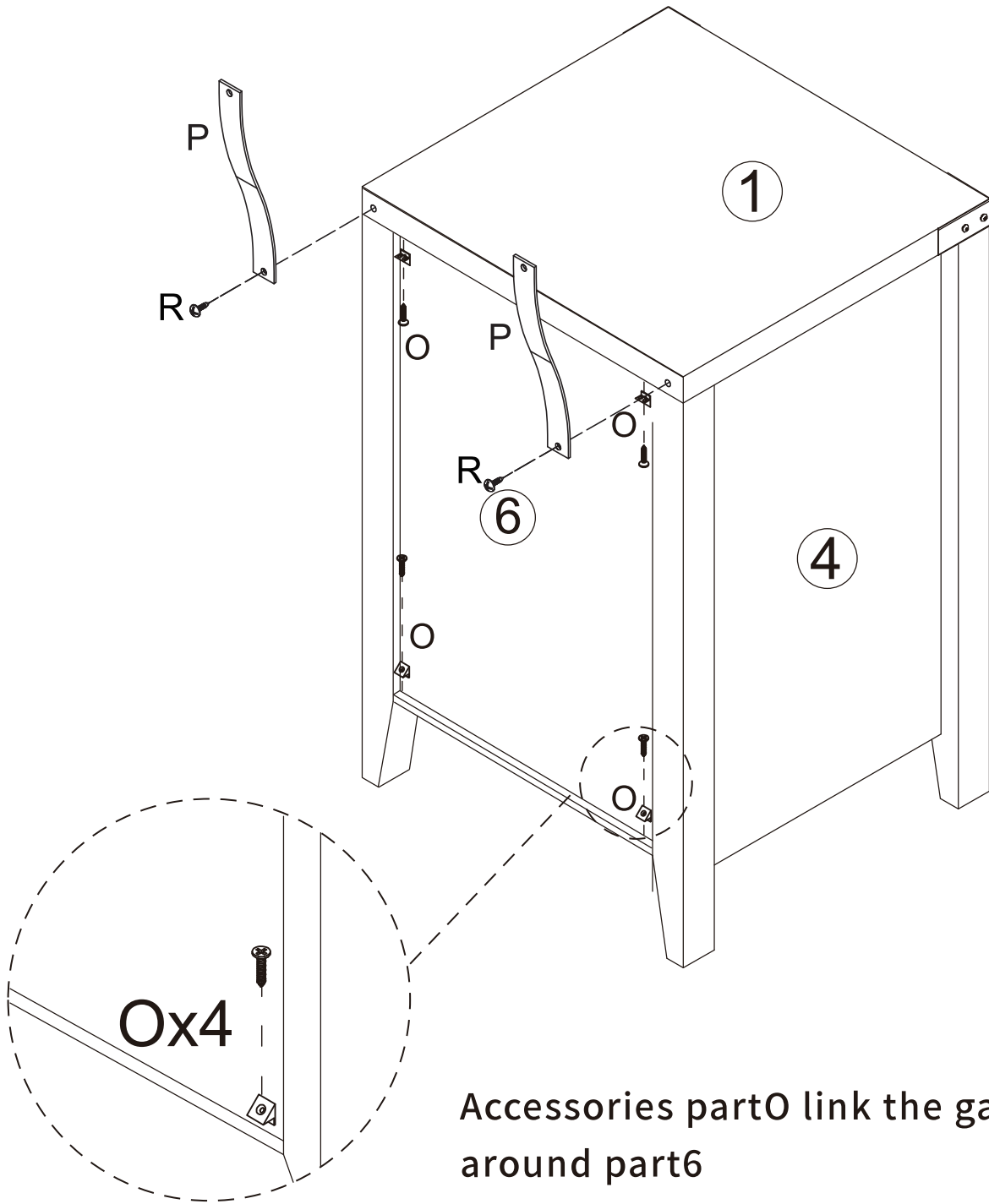



Accessories part O link the gaps around part 6

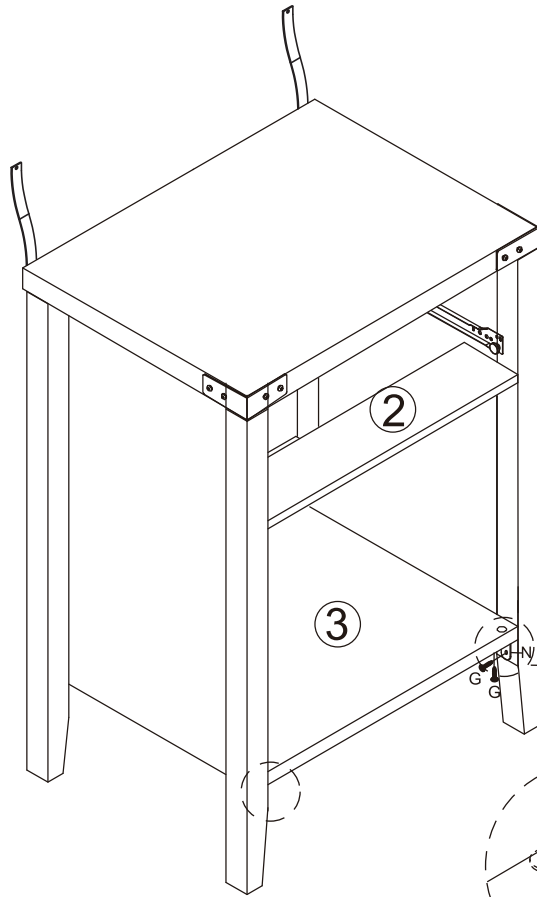

P X2	R X2	O X4
		

10



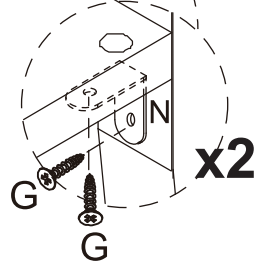



Note that the 2 partP are fixed on part3 and the table legs

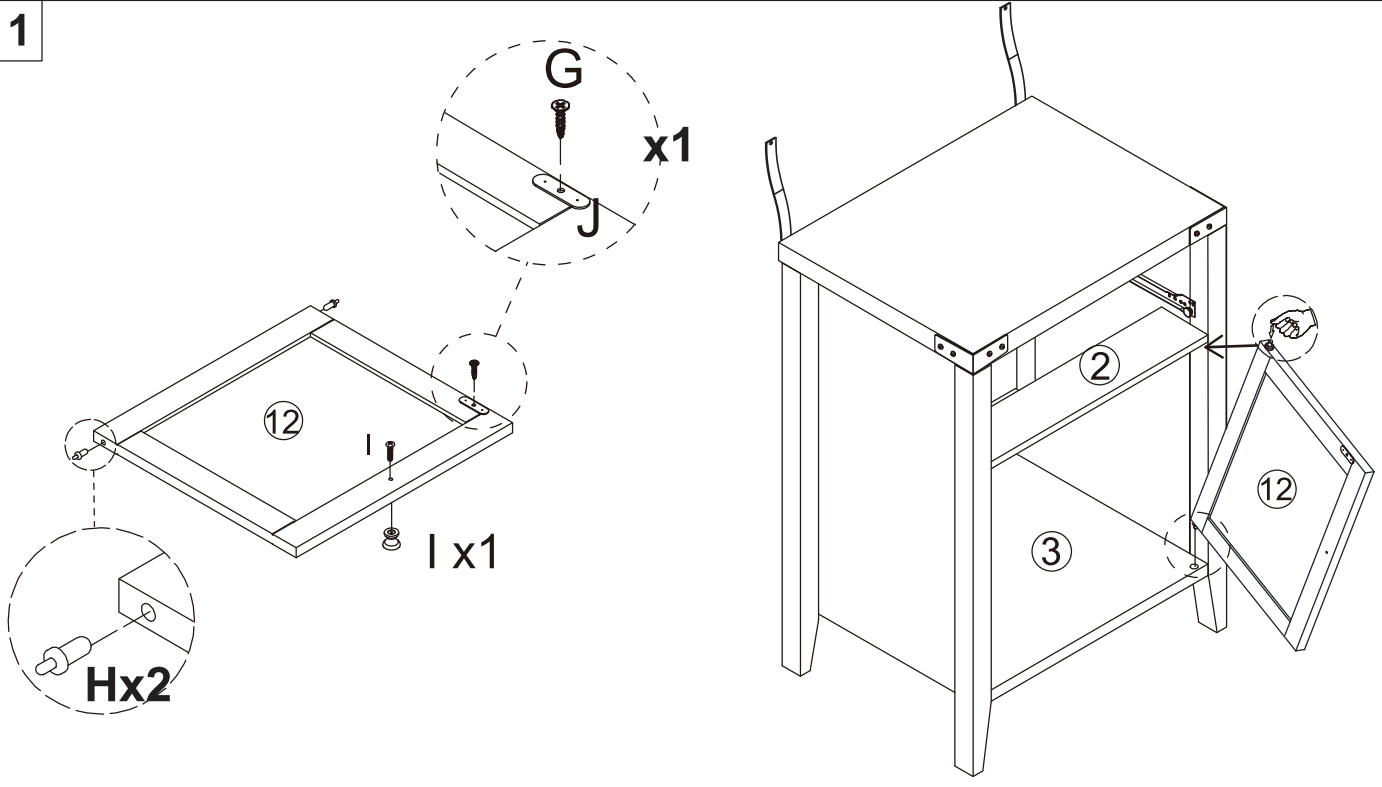

G X4
 Ø3.5x12mm
N X2



11

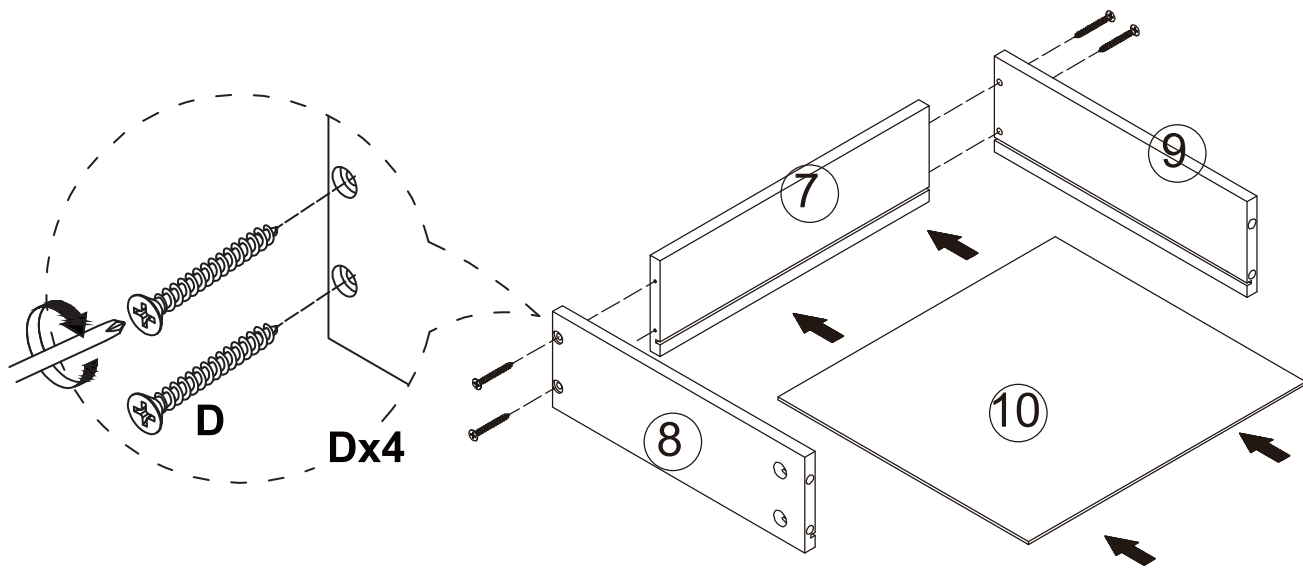

G X1	H X2	I X1	J X1
 Ø3.5x12mm			

12



D X4

Ø4x35mm

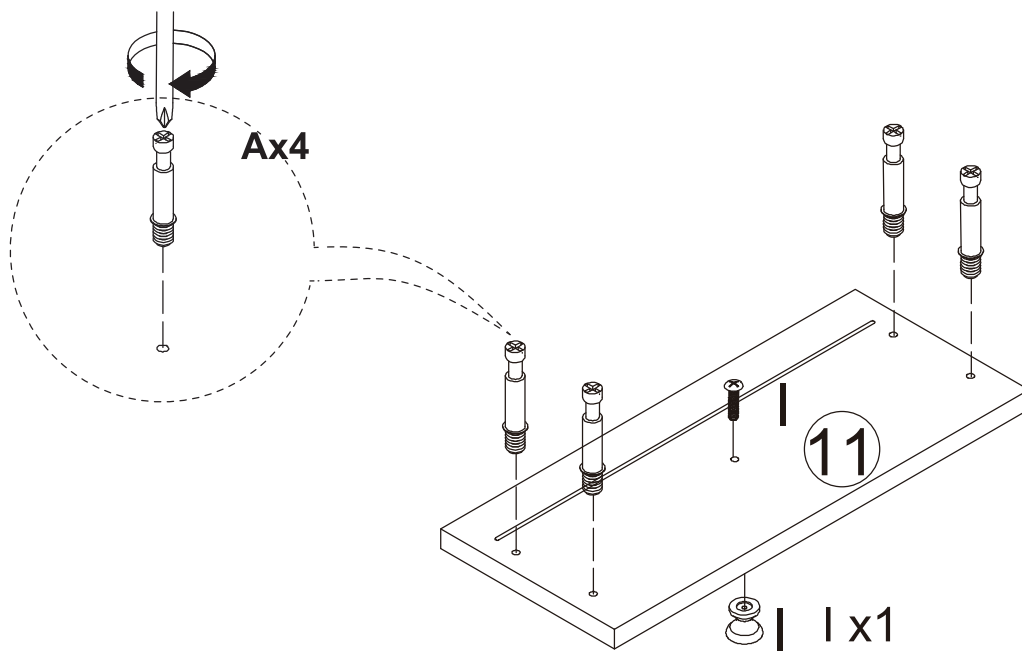
13

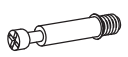

A X4

Ø6x35mm

I X1

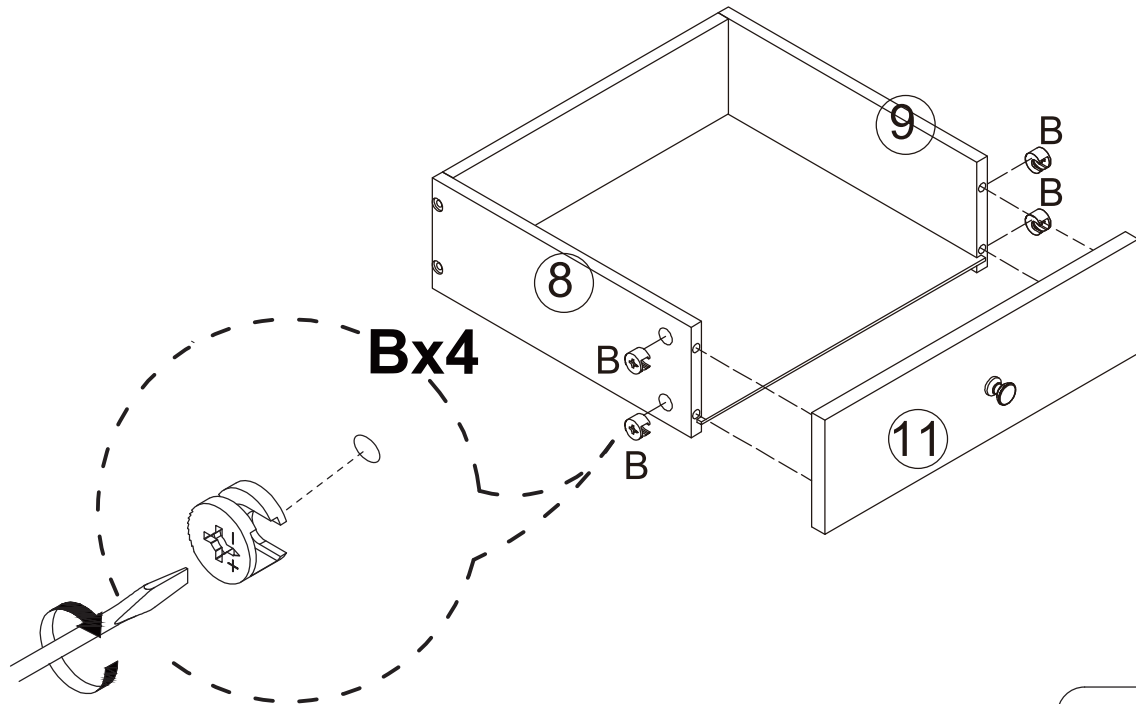

14



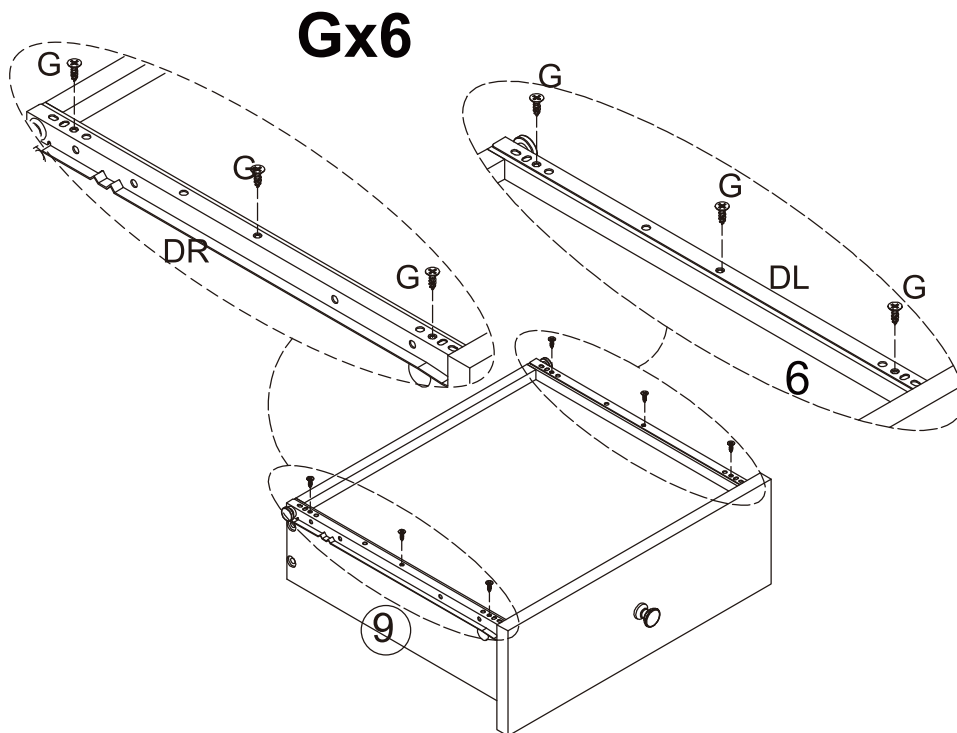

B X4

Ø15x10mm

15



G X6

Ø3.5x12mm

DL X1

DR X1

Note, when the parts partDL and DR are connected to the bottom of part8,9, pay attention to the direction

