

ASSEMBLY INSTRUCTIONS

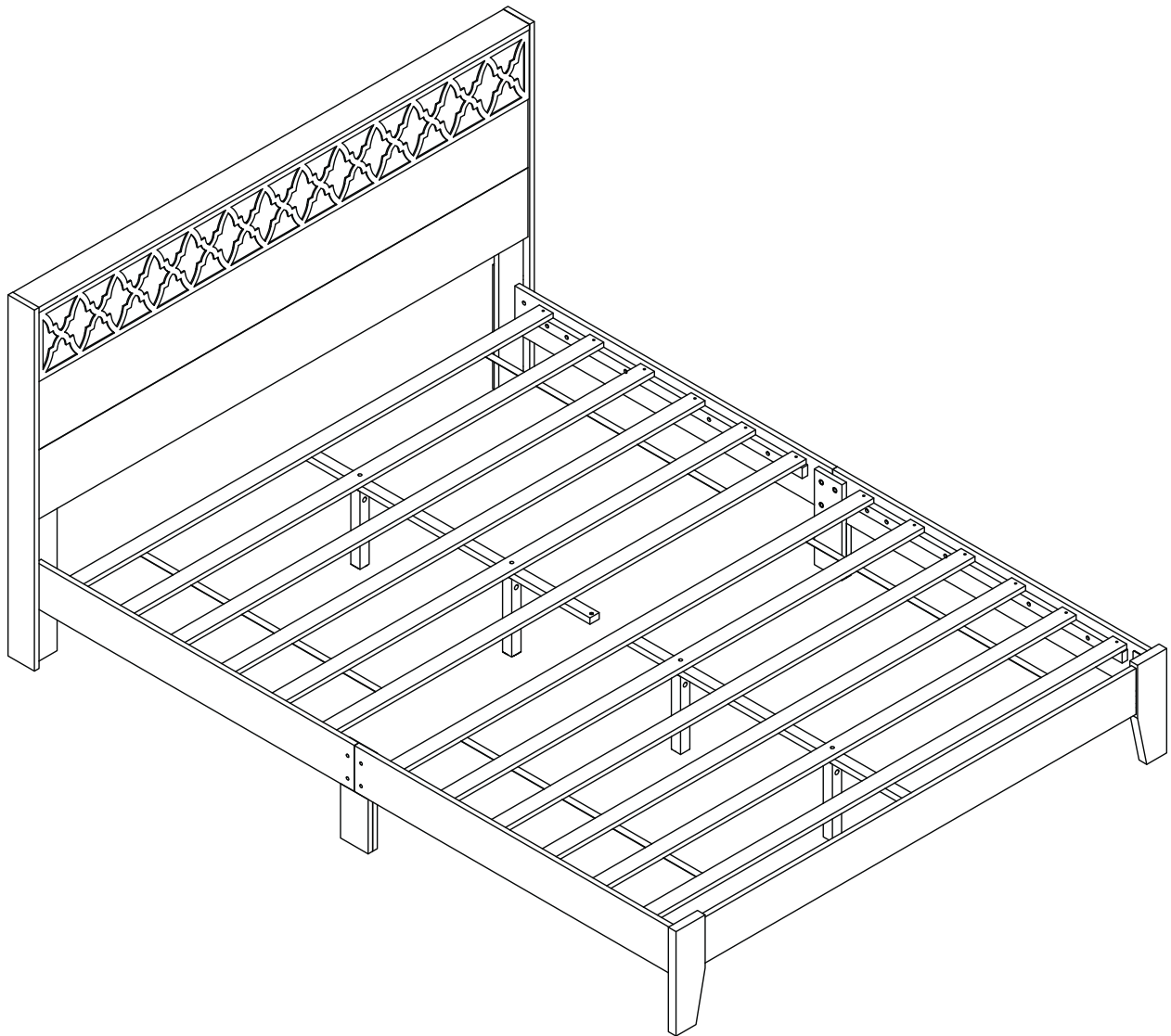

NOTES ON ASSEMBLY / NOTES POUR L'ASSEMBLAGE / NOTAS SOBRE EL ENSAMBLE

- To ensure ease of assembly read all instructions before assembly and follow step by step illustrations.
- Keep instructions for future use.
- Adult assembly required.  2 person required. 
- Due to the presence of small parts during assembly, keep out of reach of children until assembly is complete.

- Pour assurer l'assemblage facile veuillez lire toutes les instructions avant l'assemblage et veuillez suivre les illustrations pour chaque etapes.
- Veuillez garder ces instructions pour l'usage ulterieur.
- Assemblage requis pas un adulte.  2 personnes requises. 
- Due a la presence de petite pieces durant l'assemblage, veuillez garder hors de porter des enfants jusqu'a ce que l'assemblage soit completer.

- Para garantizar la facilidad de ensamble lea las instrucciones antes de iniciar y siga paso a paso las ilustraciones.
- Guarde las instrucciones para futuras referencias.
- El ensamble requiere de un adulto.  2 personas requeridas. 
- Debido a que hay piezas pequeñas, mantenga fuera del alcance a los niños durante el ensamble, hasta que haya terminado.

MAINTENANCE TIPS / CONSEILS D'ENTRETIEN / CONSEJOS DE MANUTENIMIENTO

- Never let liquids or damp cloths sit on this furniture.
- Never use chemical cleaning products. They can damage the finish. For cleaning, use only a slightly damp cloth and wipe dry.
- To avoid dulling of the finish, do not place furniture in direct sunlight.
- Do not put plastic or rubber rings under appliances. Use cloth of felt protectors.
- To clean, use a soft or slightly damp cloth, then wipe with a clean, dry cloth.

- Ne jamais laisser de liquide ou linge humide sur le meuble.
- Ne jamais utiliser de nettoyeurs à base de produits chimiques, cela va endommager le fini. Utiliser seulement un linge légèrement humide.
- Ne pas placer le meuble directement au soleil pour prévenir le ternissement.
- Évitez de déposer des appareils avec des rondelles de plastique ou de caoutchouc. Utilisez un protecteur en tissu ou en feutre.
- Pour nettoyer, utilisez un linge doux ou légèrement humecté. Essayez par la suite avec un linge propre et sec.

- Nunca deje un líquido o un trapo húmedo sobre el mueble.
- Nunca utilice limpiadores a base de químicos, estos dañaran le acabado. Use sólo un paño húmedo.
- No esponga el mueble directamente al sol para prevenir empañamiento.
- Evite apoyar aparatos con redondeles de plástico o de goma. Utilizar un protector de tela o de fieltro.
- Para limpiar, utilice un trapo suave o ligeramente humedecido. Seque luego con un trapo limpio y seco.

MINIFIX CAM & MINIFIX BOLT
CAMÉRA MINIFIX & BOULON MINIFIX
CÁMARA MINIFIX & PERNO MINIFIX

MINIFIX BOLT
BOULON MINIFIX
PERNO MINIFIX

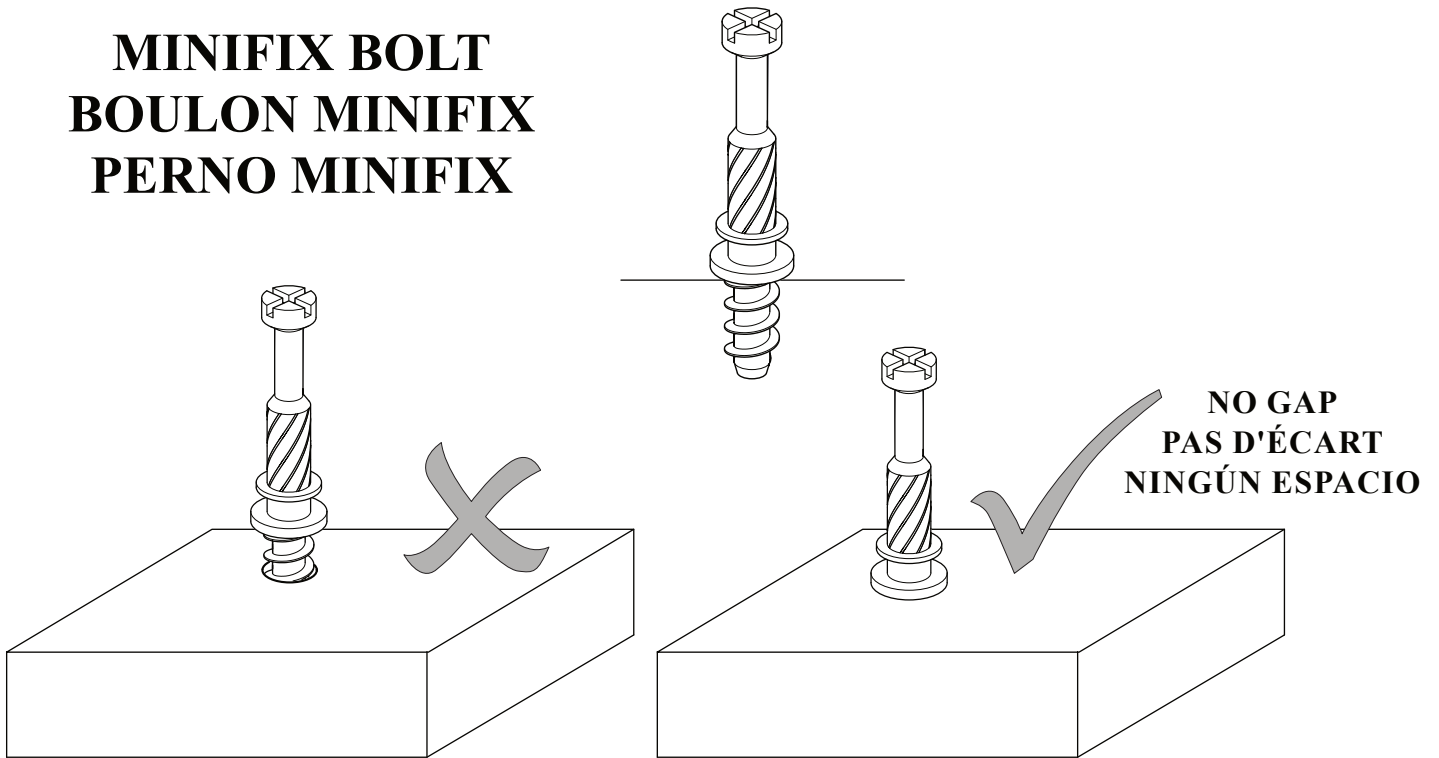



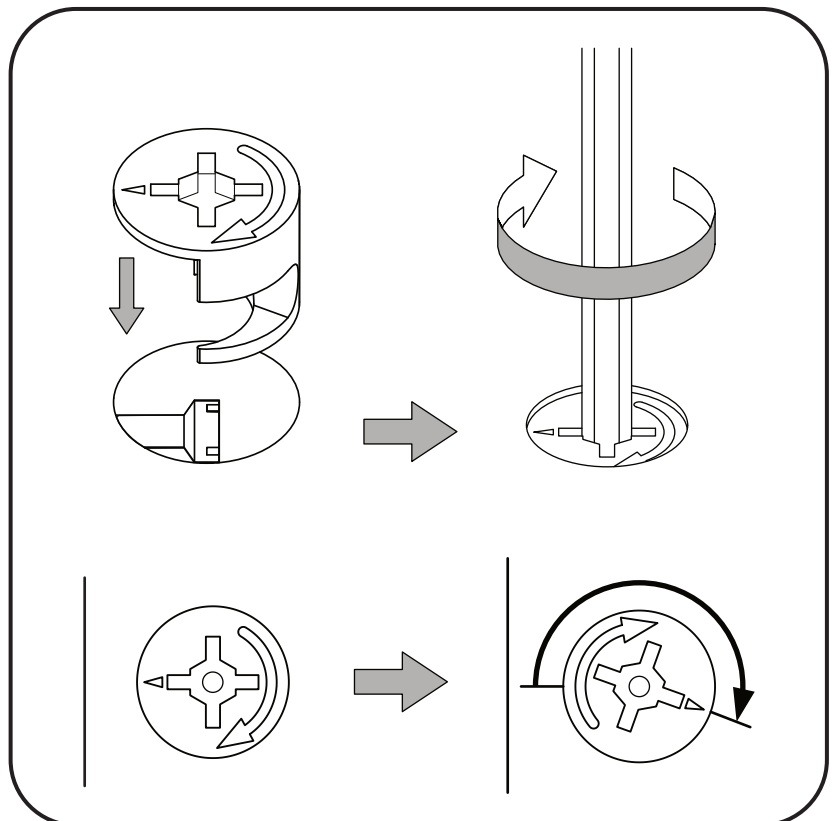
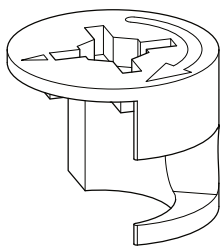

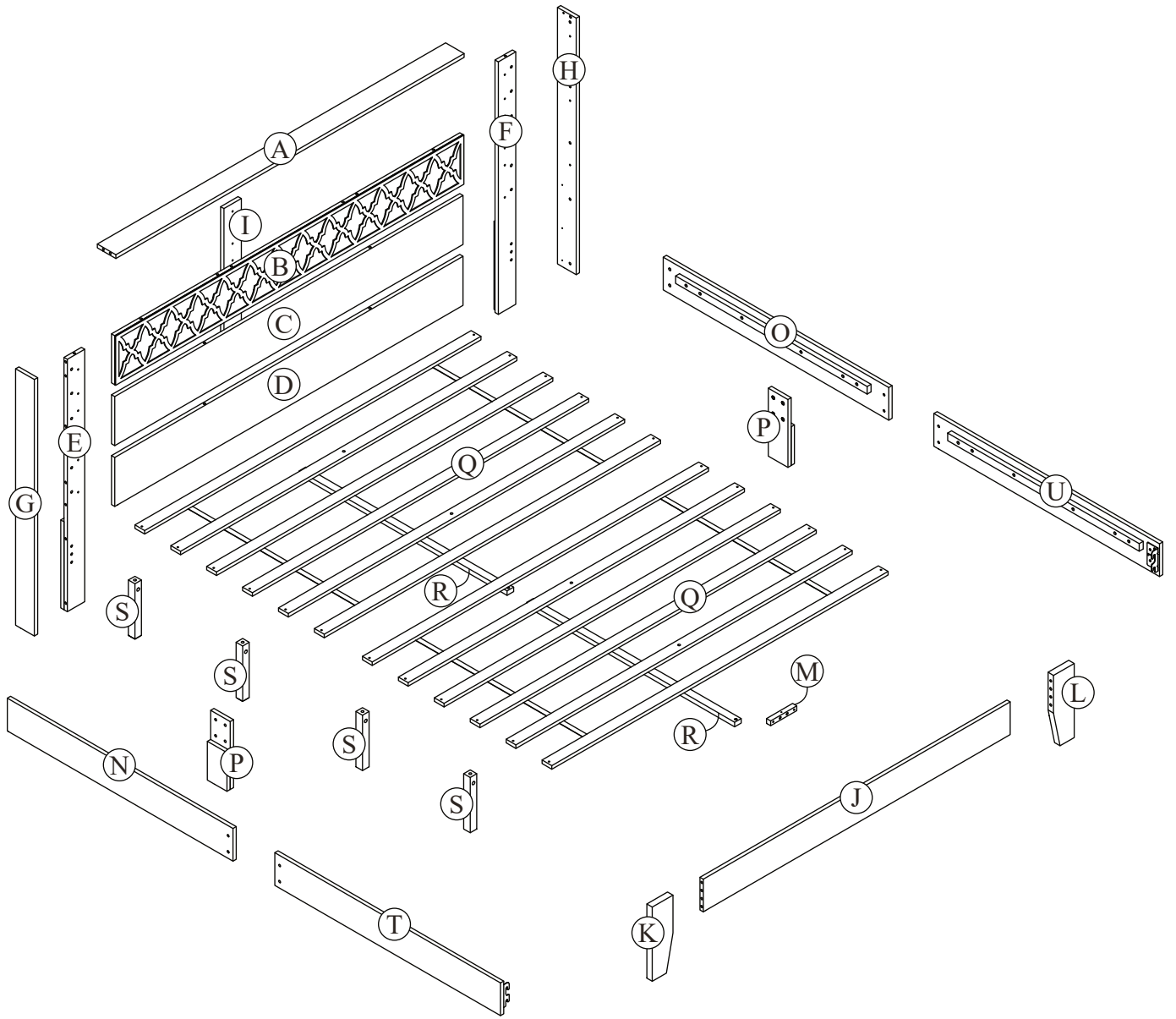









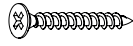
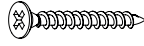

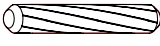
MINIFIX CAM
CAMÉRA MINIFIX
CÁMARA MINIFIX



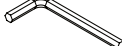
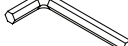
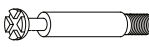

HARDWARE

QUINCAILLERIE / HERRAJE

| | | | | | |
|-----|---|-----|--|-----|---|
| (A) | JCBC M6x30mm  8 units | (B) | JCBB M8x70mm  4 units | (C) | Spring Washer M6x13mm  8 units |
| (D) | Flat Washer M6x19mm  8 units | (E) | Screw M3.5x15mm  12 units | (F) | Screw M4x28mm  18 units |
| (G) | Screw M4x32mm  27 units | (H) | Dowel M8x20mm  17 + 2 units | (I) | Dowel M8x30mm  18 + 2 units |
| (J) | Dowel M8x50mm  8 units | (K) | Minifix Bolt EU24  12 units | (L) | Minifix Cam 15/12  16 units |
| (M) | JCBB M8x16mm  4 units | (N) | Allen Key M4  1 unit | (O) | Allen Key M5  1 unit |
| (P) | Bolt M6.8x40mm  4 units | (Q) | PVC L Bracket  6 units | (R) | Barrel Nut M6x10x13mm  8 units |
| (S) | Barrel Nut M8x12x18mm  4 units | (T) | Flat Washer M10x22mm  4 units | (U) | JCBC M6x70mm  4 units |

- Hardware quantity may supplied more than it required. Please keep spares and tools for future use.
- La cantidad de hardware puede suministrarse más de lo requerido. Guarde los repuestos y las herramientas para uso futuro.
- La quantité de matériel peut fournir plus que nécessaire. Veuillez conserver les pièces de rechange et les outils pour une utilisation future.

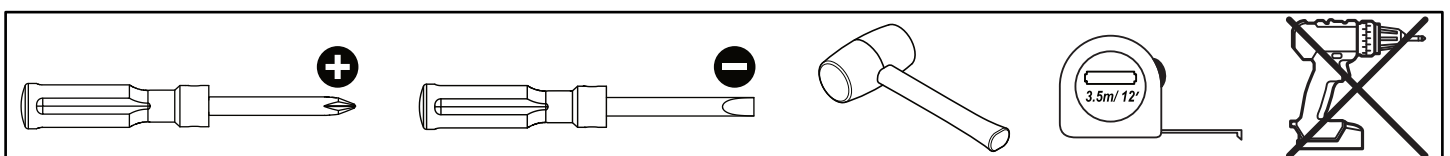

TOOLS NOT INCLUDED

OUTILS PAS INCLUS / HERRAMIENTAS NO INCLUIDAS

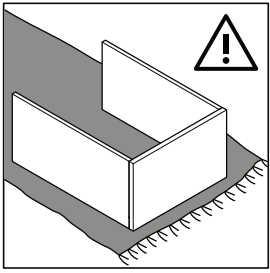

STEP 1



| | |
|---|---|
|  |  |
| H x 15 | J x 4 |

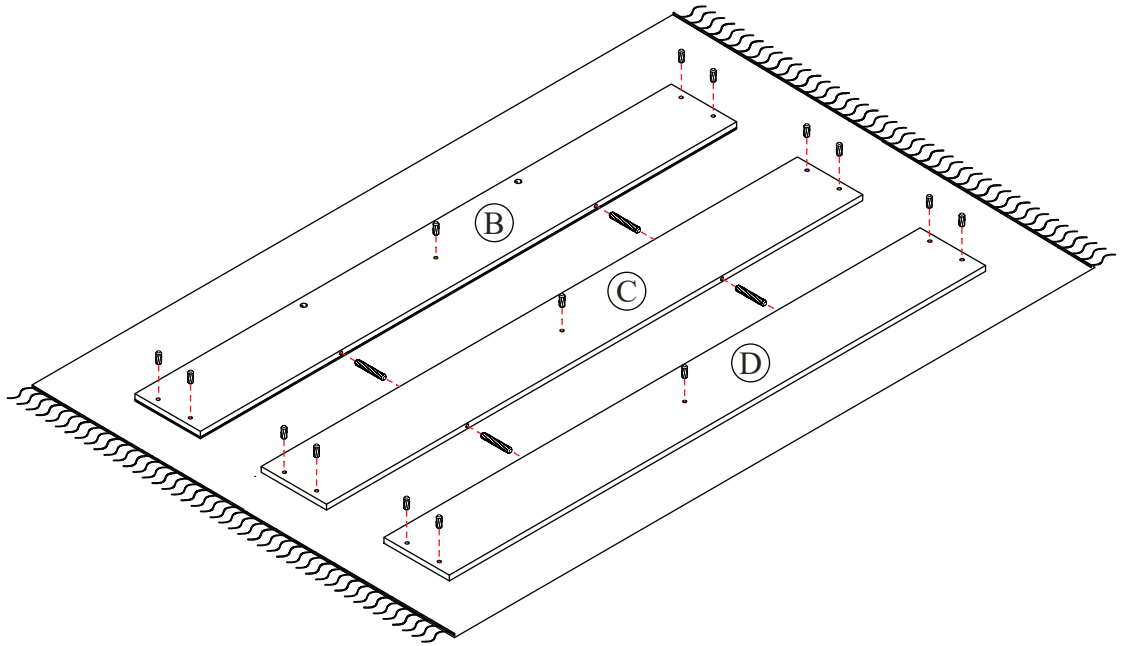
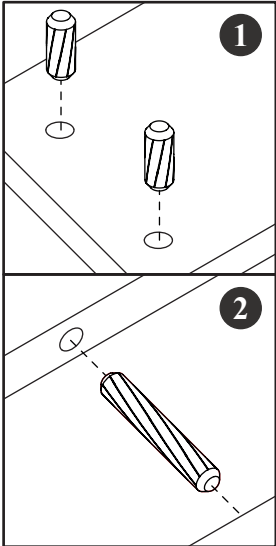

STEP 2

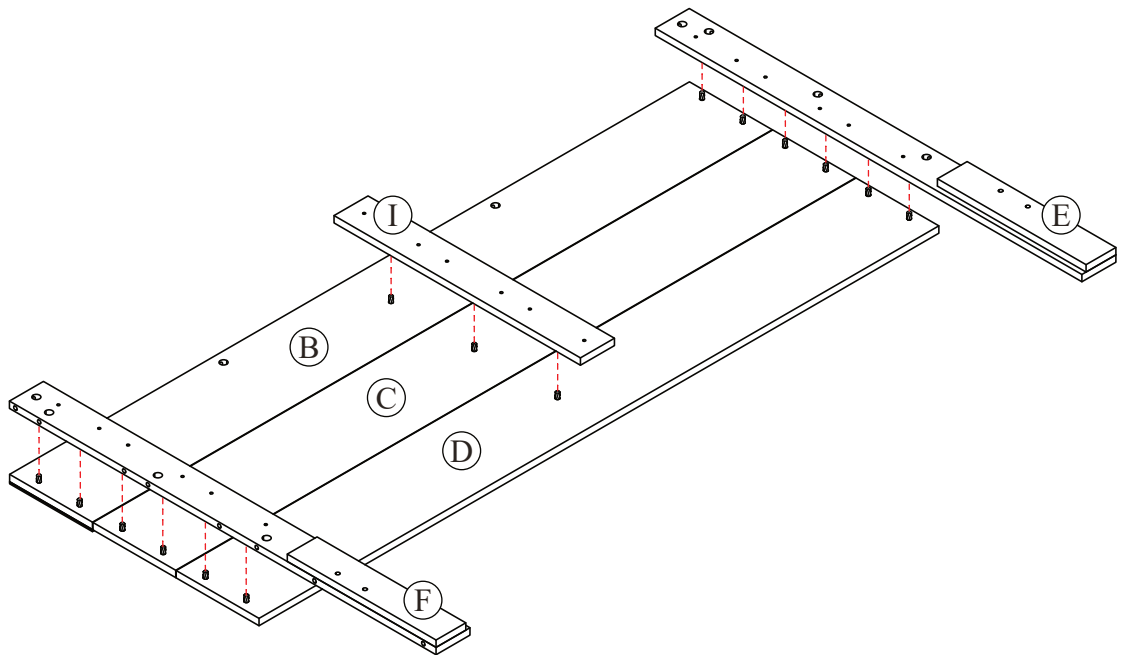
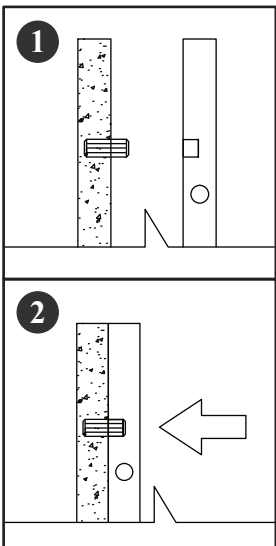

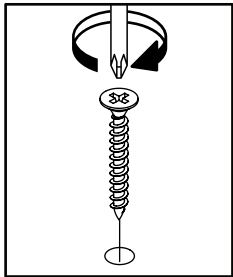
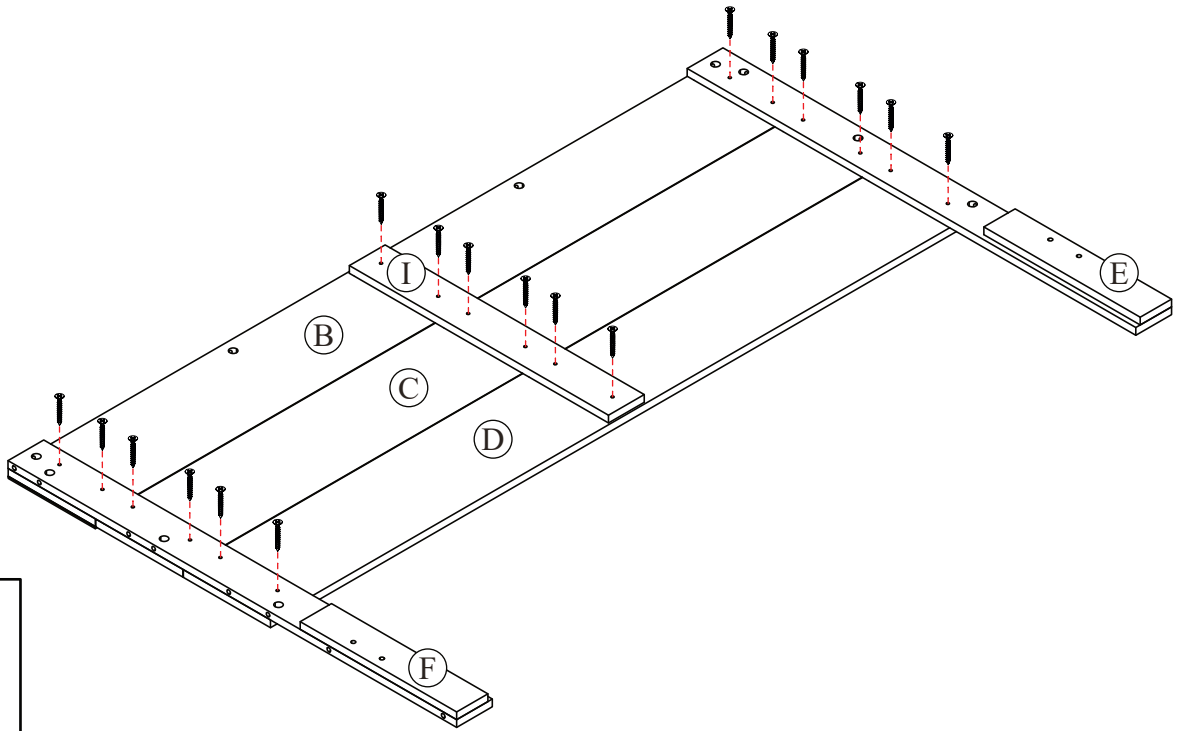
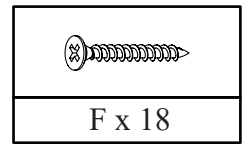

STEP 3

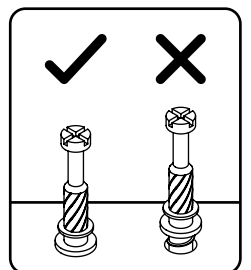
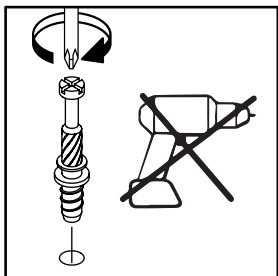
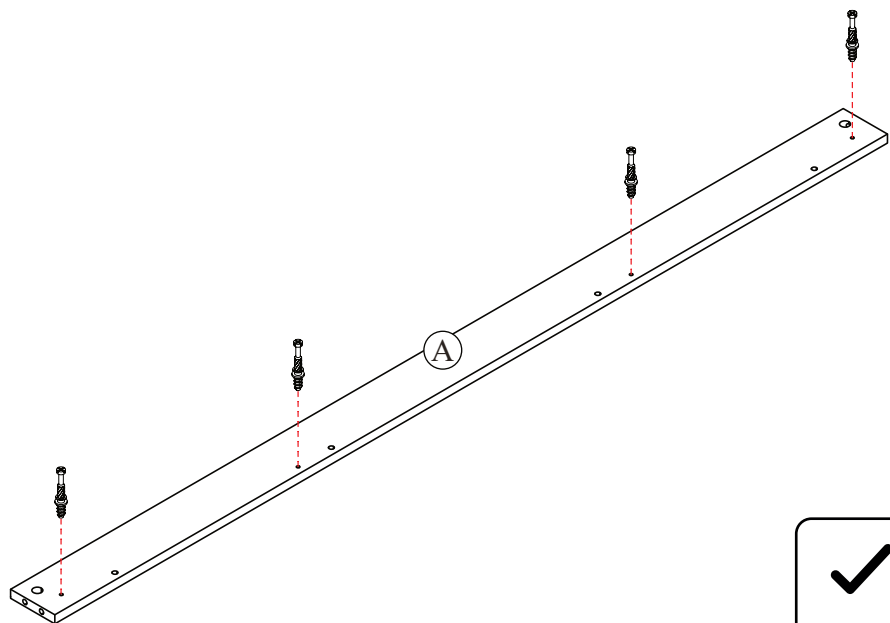
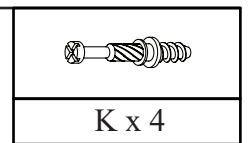

STEP 4



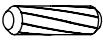

STEP 5

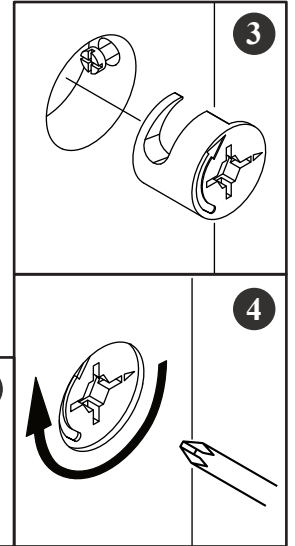
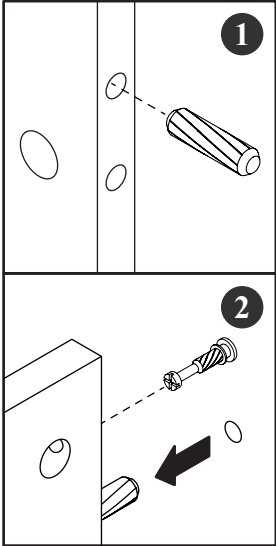
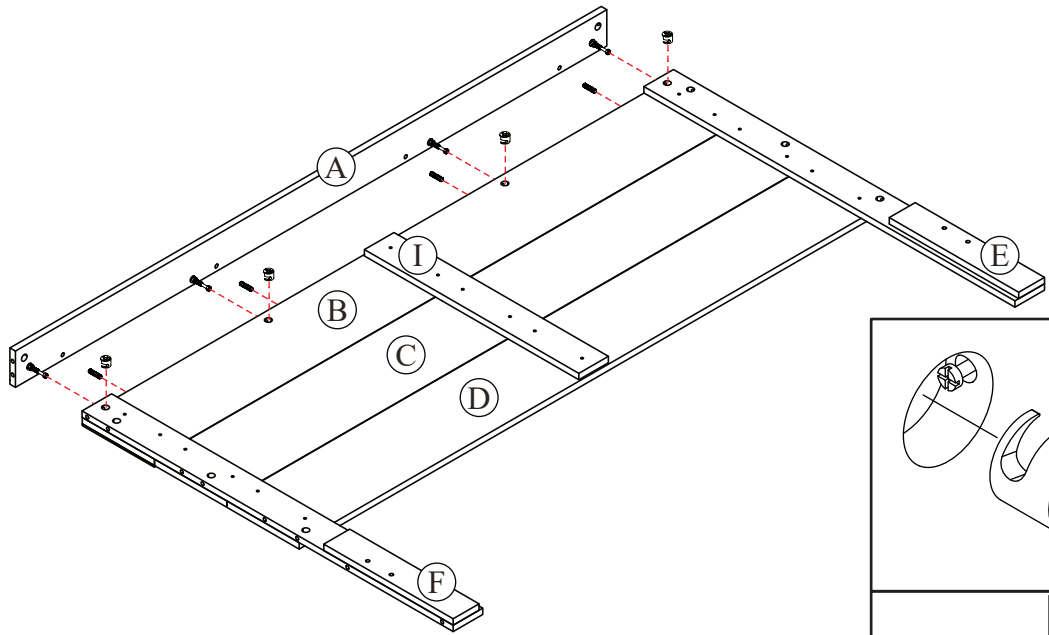
| | |
|---|--|
|  |  |
| I x 4 | L x 4 |



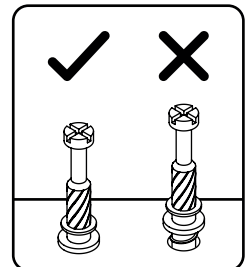
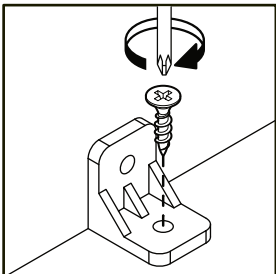
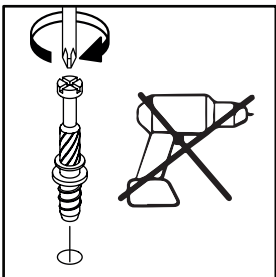
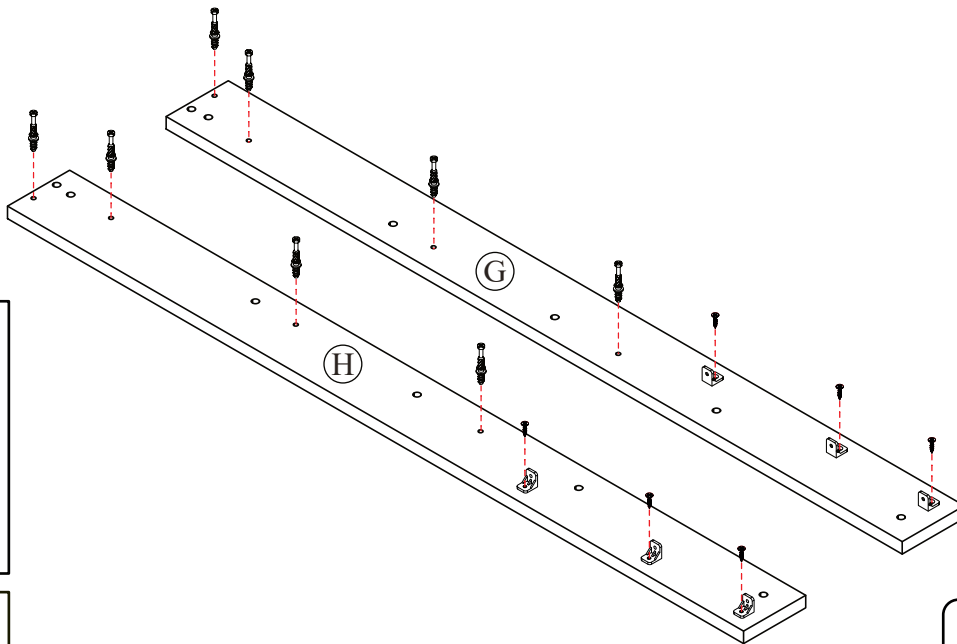

STEP 6

| | | |
|---|---|---|
|  |  |  |
| E x 6 | K x 8 | Q x 6 |

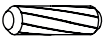

STEP 7

| | |
|---|---|
|  |  |
| I x 12 | L x 8 |

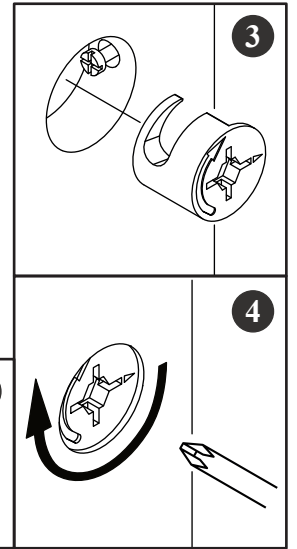
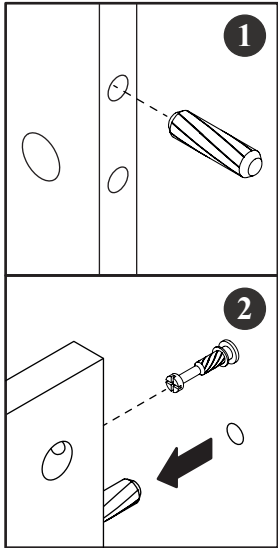
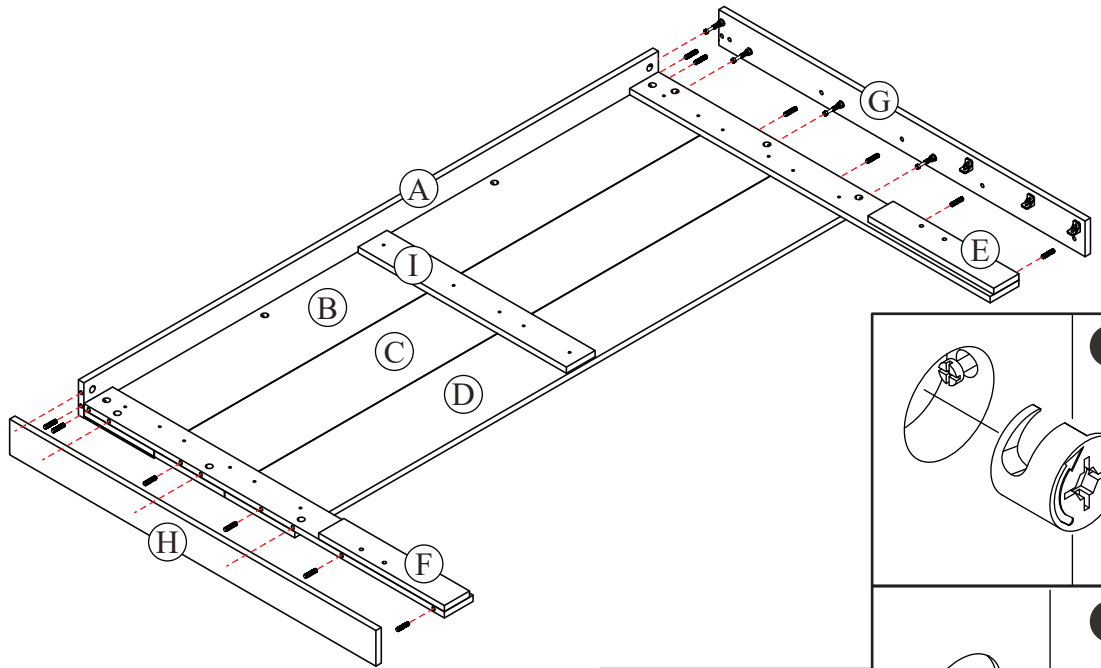

STEP 8

| |
|---|
|  |
| E x 6 |

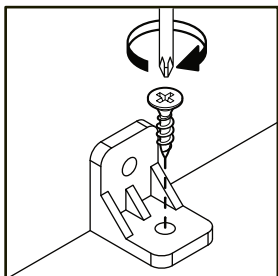
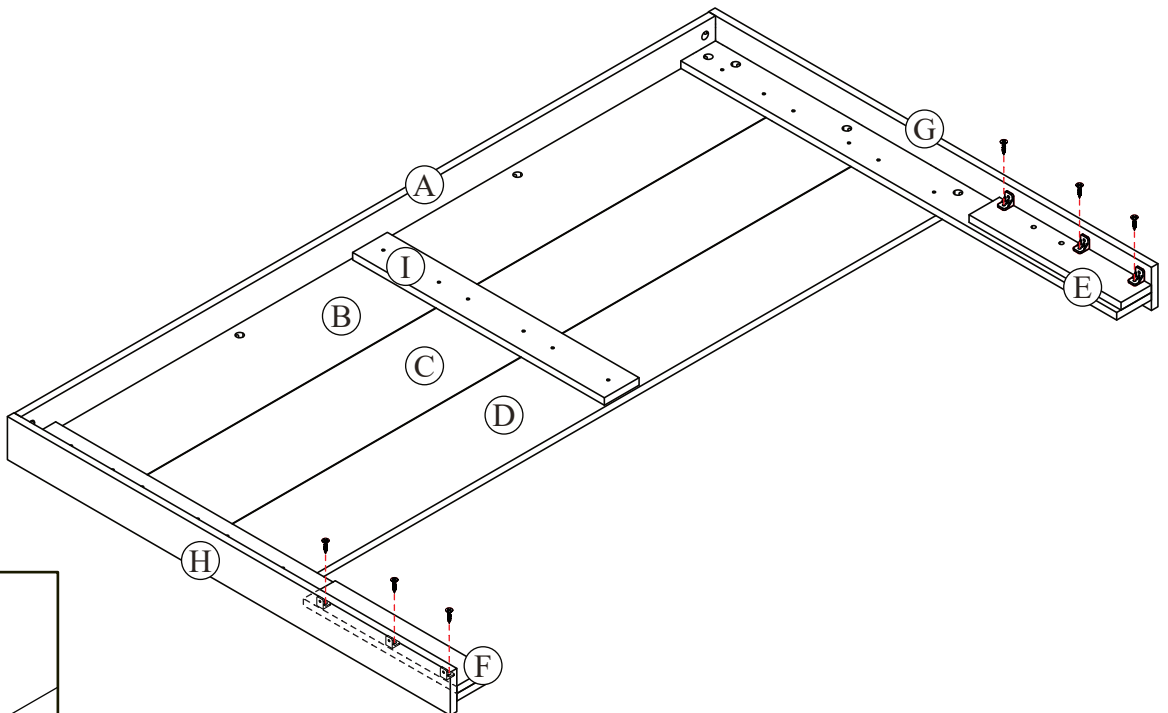

STEP 9

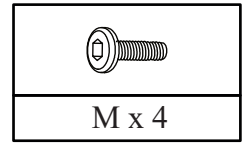

*Do Not Tighten

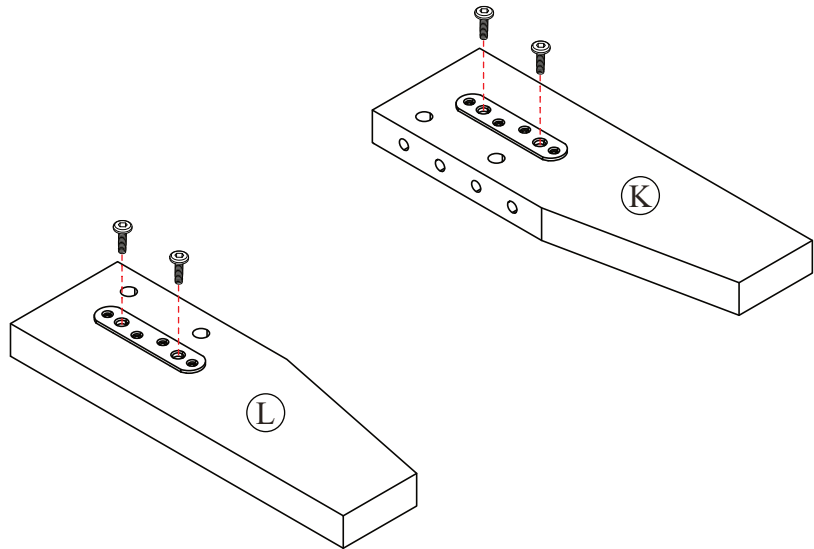
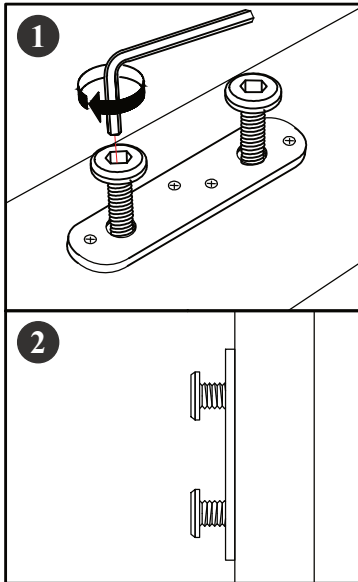

STEP 10

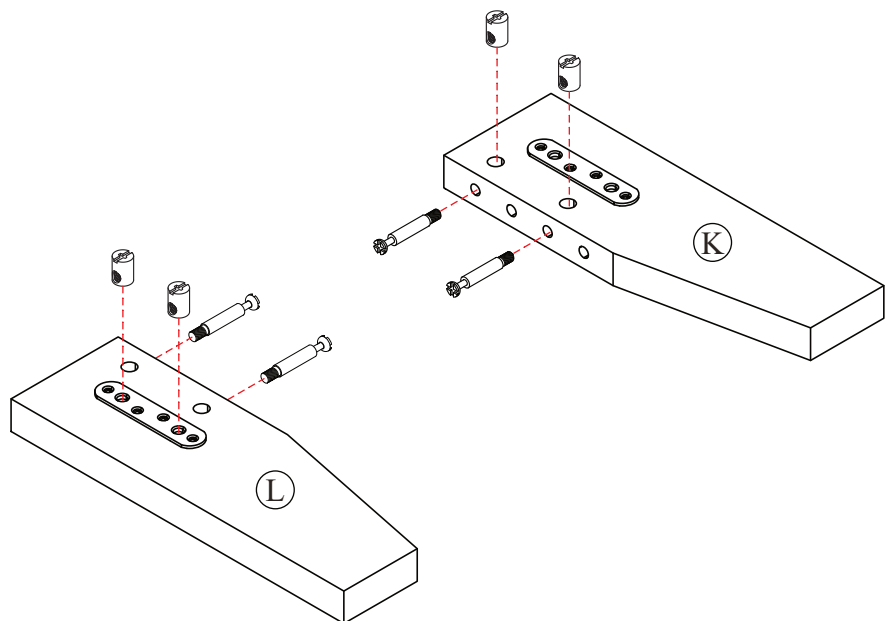
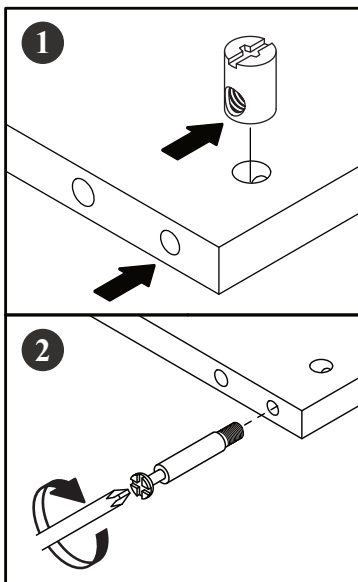
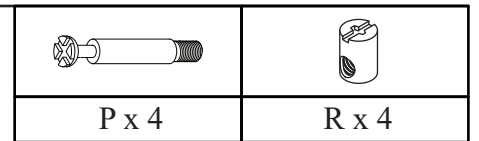

STEP 11

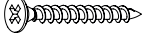
| | |
|---|---|
|  |  |
| H x 2 | G x 2 |

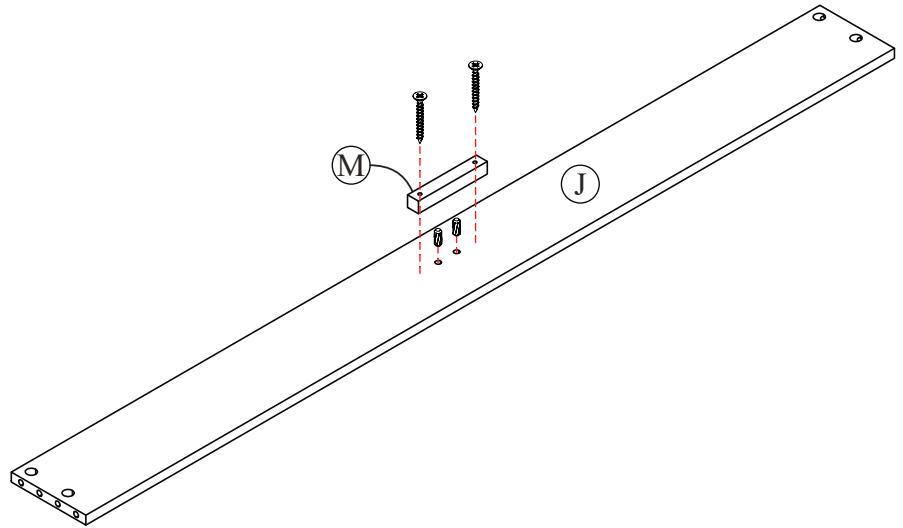
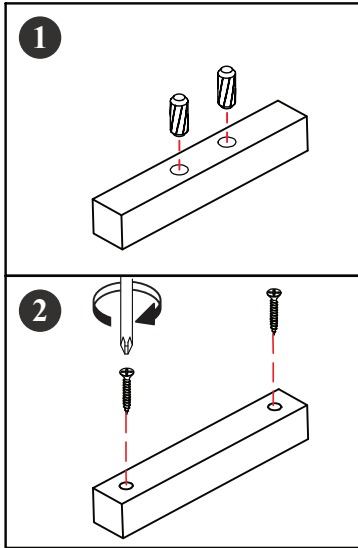

STEP 12

| |
|---|
|  |
| J x 4 |

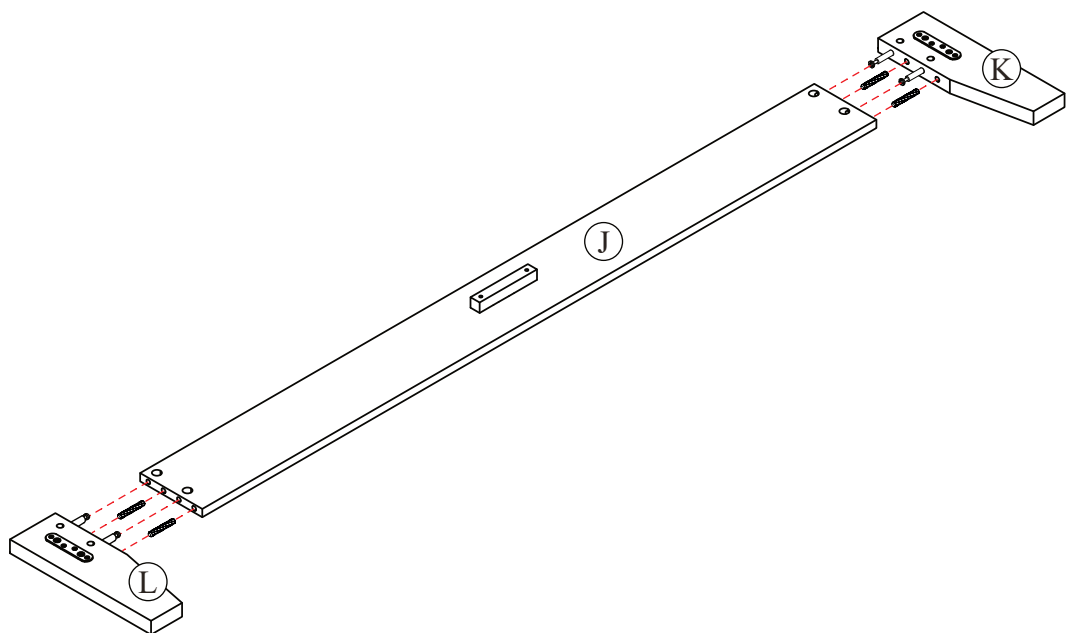
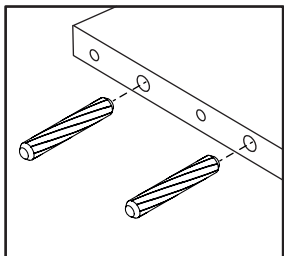

STEP 13

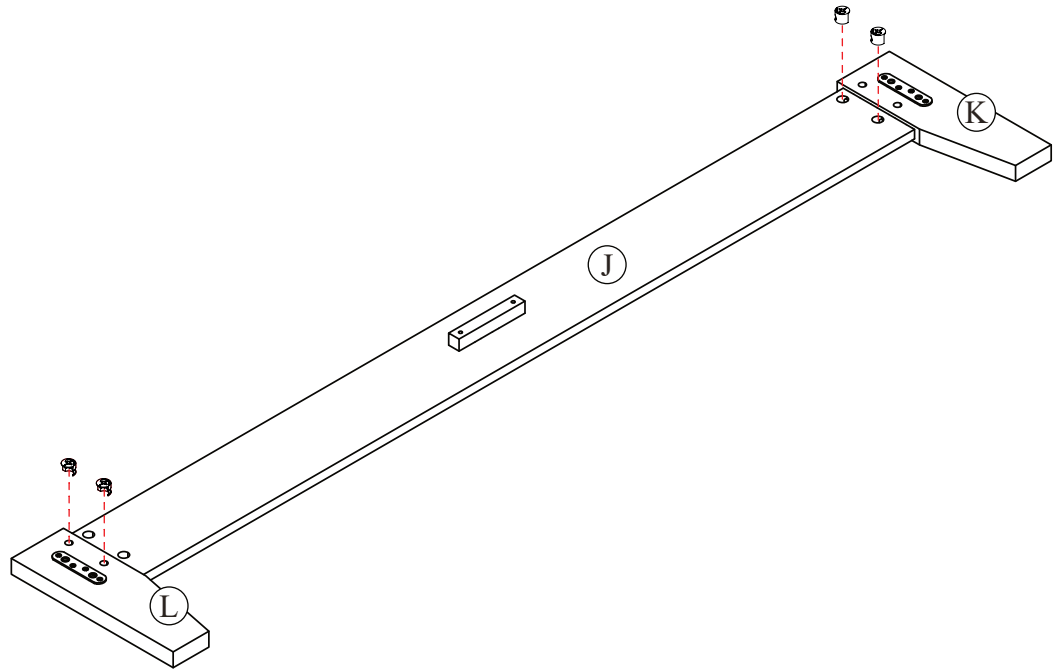
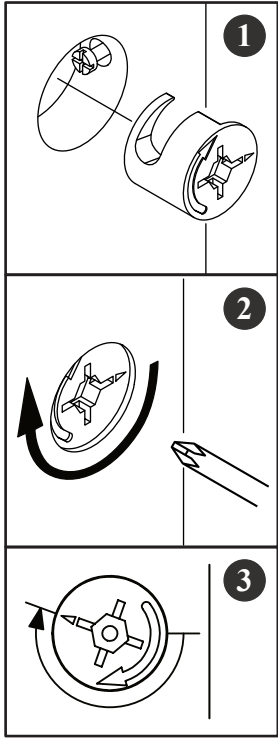
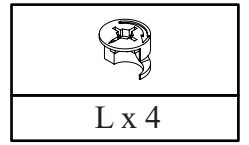

STEP 14

| | | |
|-------|-------|-------|
| | | |
| A x 8 | C x 8 | D x 8 |

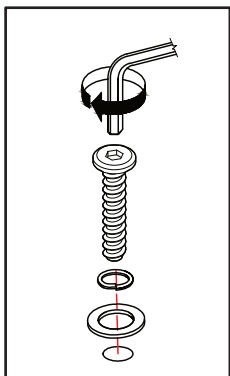
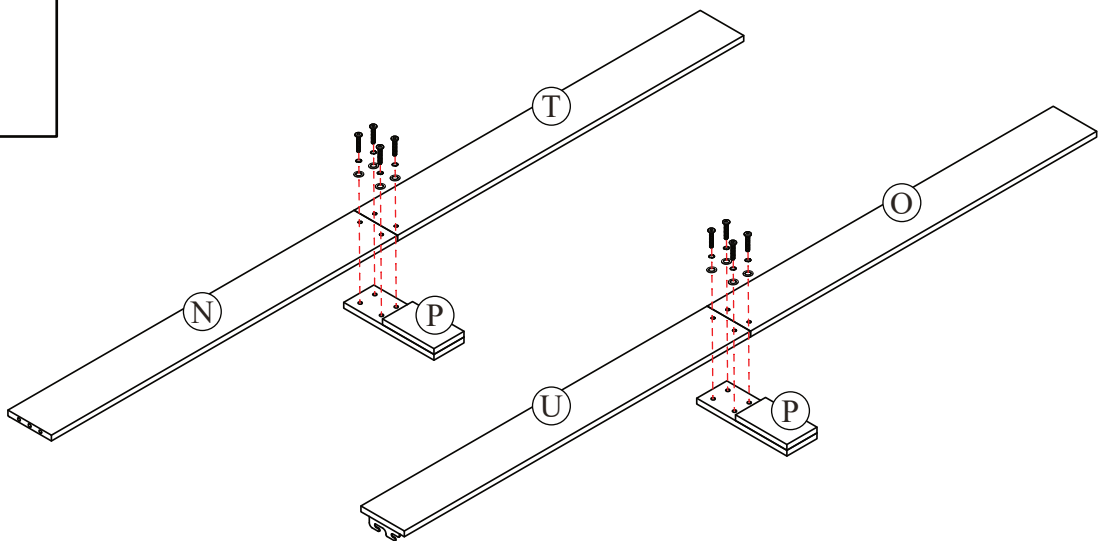
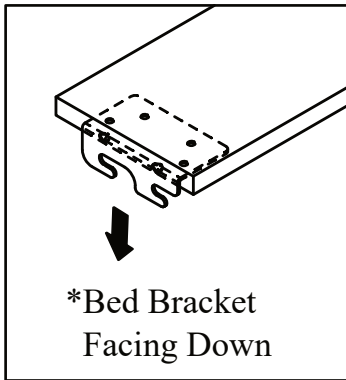

STEP 15

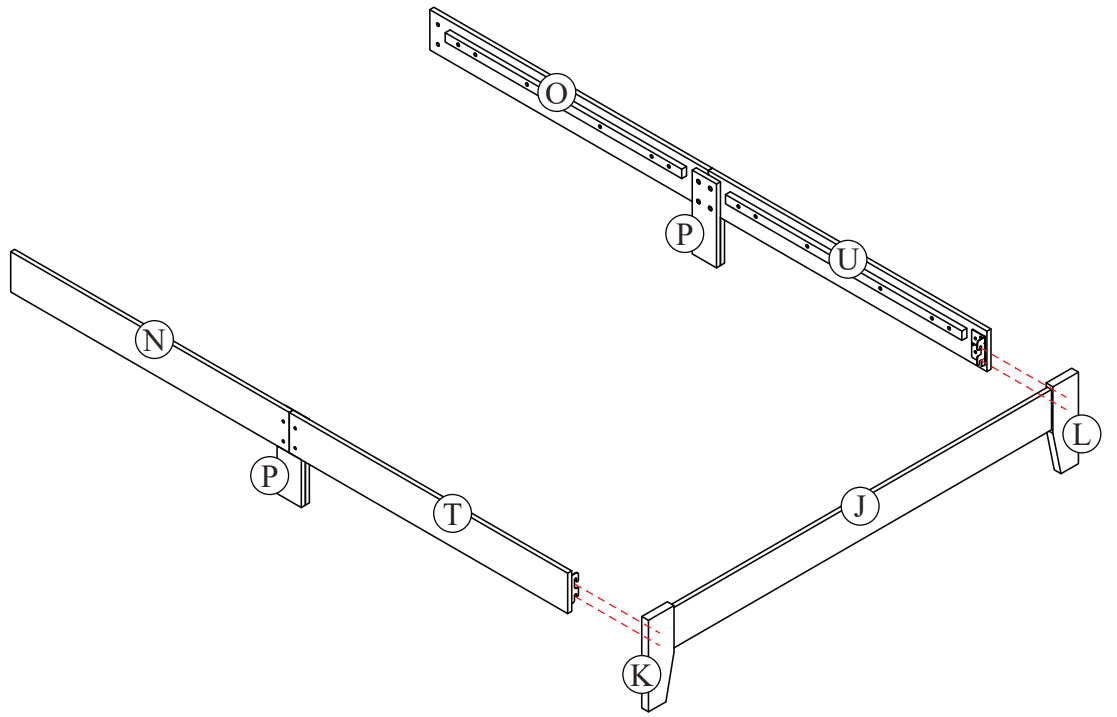
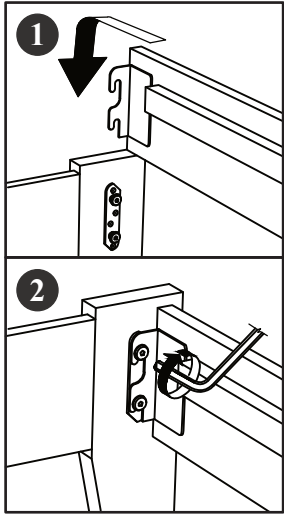

*Tighten

STEP 16

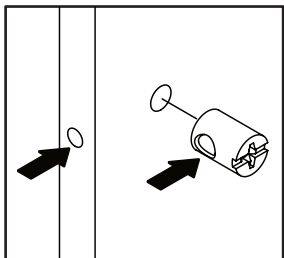
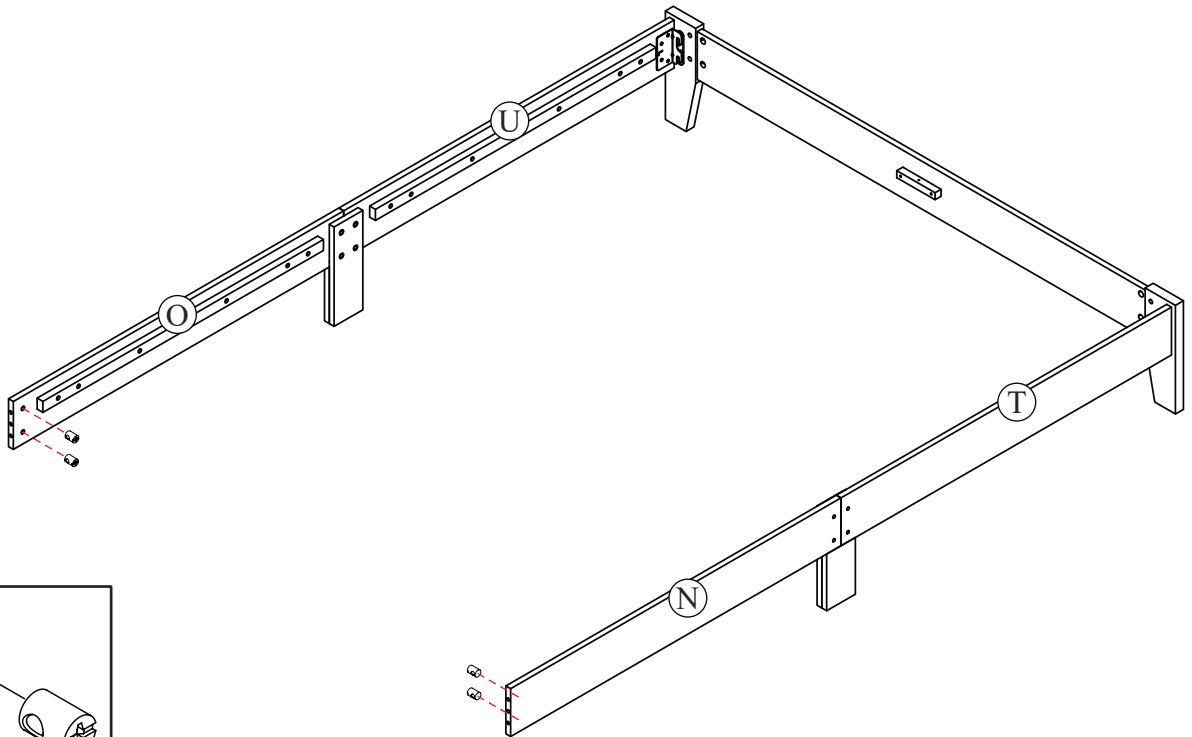
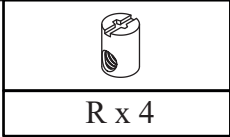

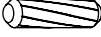
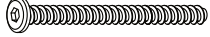

STEP 17

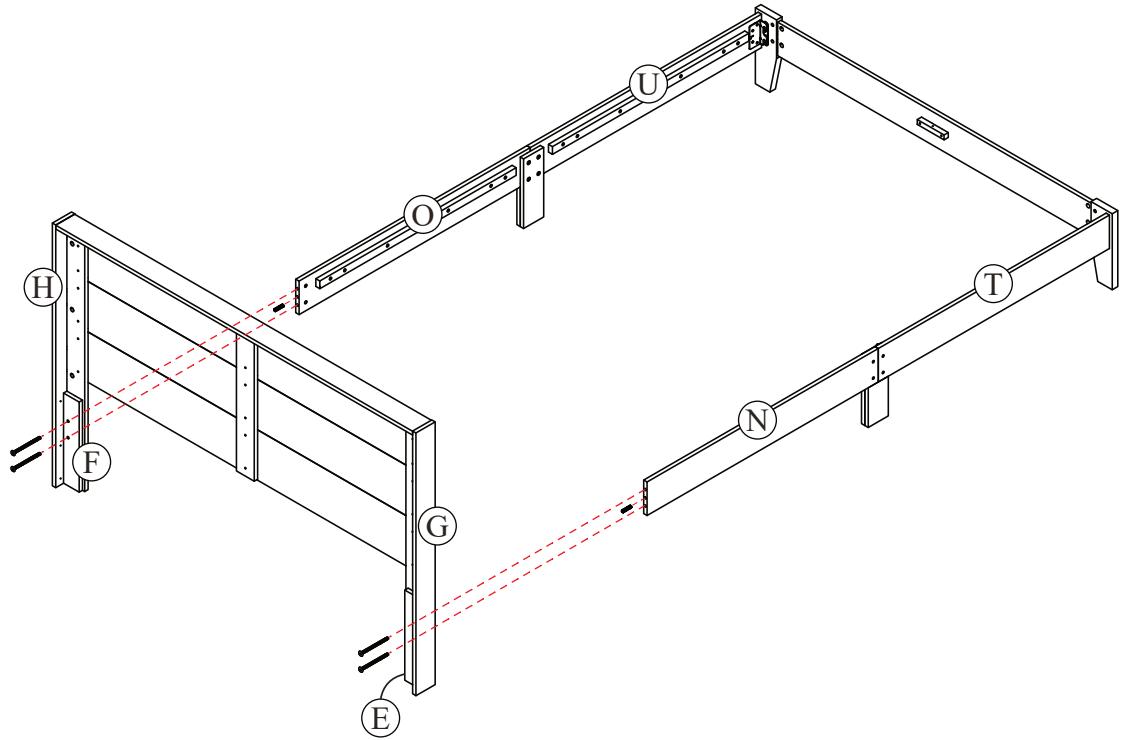
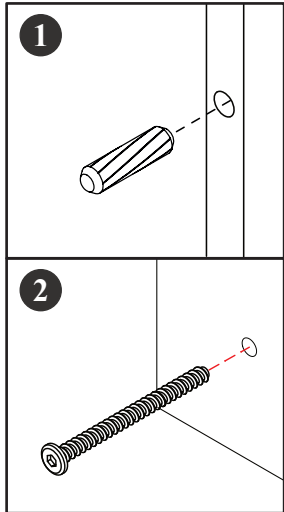
| | |
|---|---|
|  |  |
| I x 2 | U x 4 |



STEP 18

| | |
|---|---|
|  |  |
| B x 4 | S x 4 |

| |
|---|
|  |
| T x 4 |

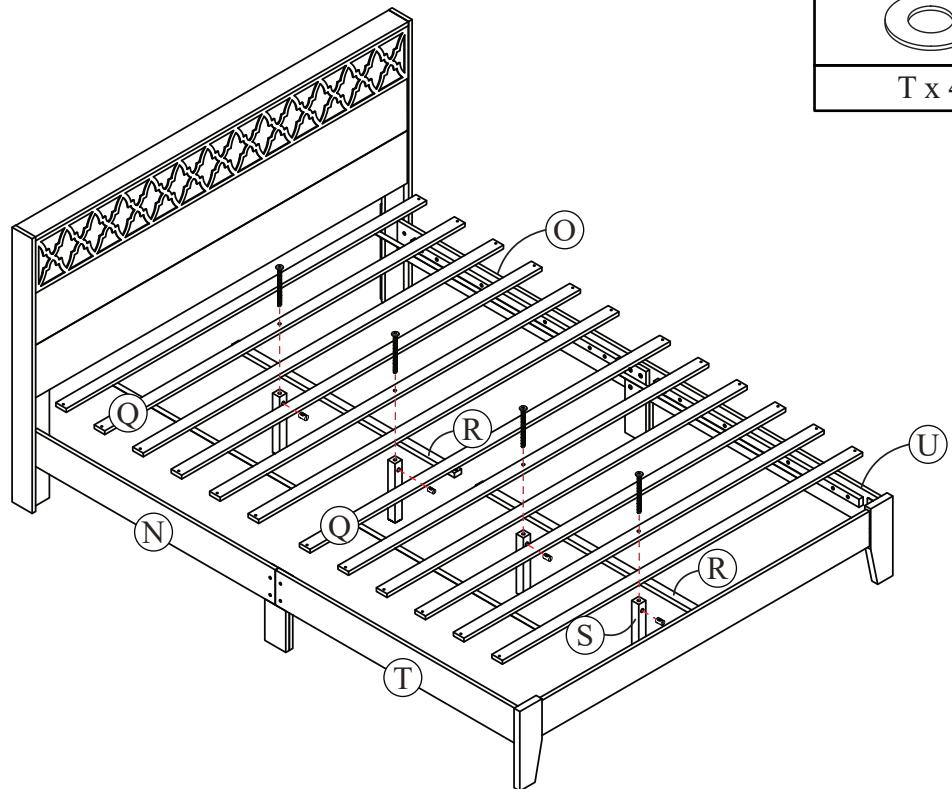
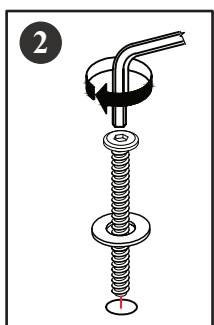
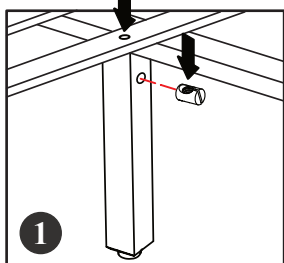

STEP 19

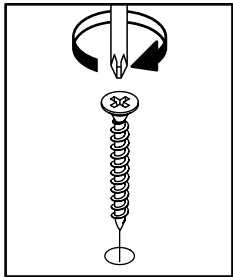
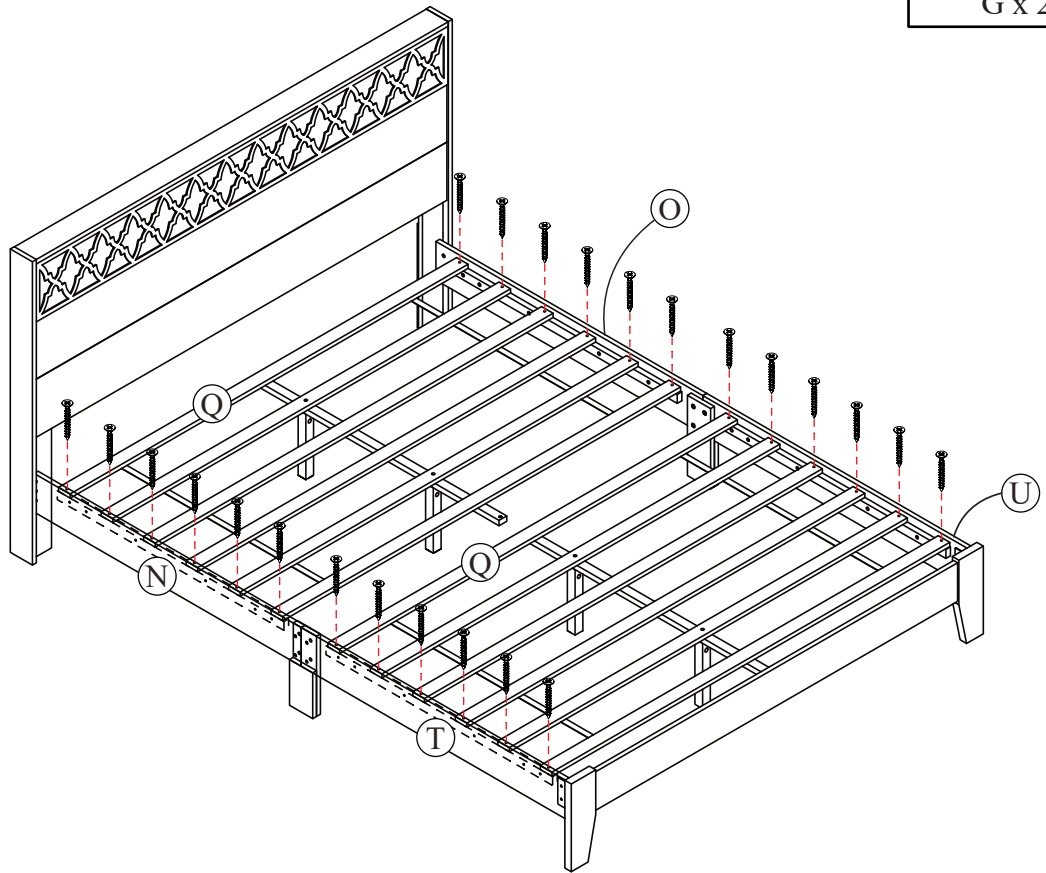
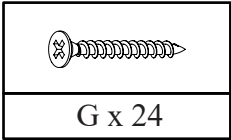

STEP 20

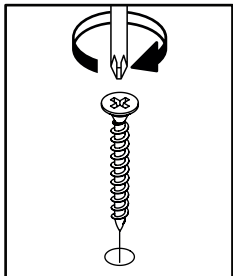
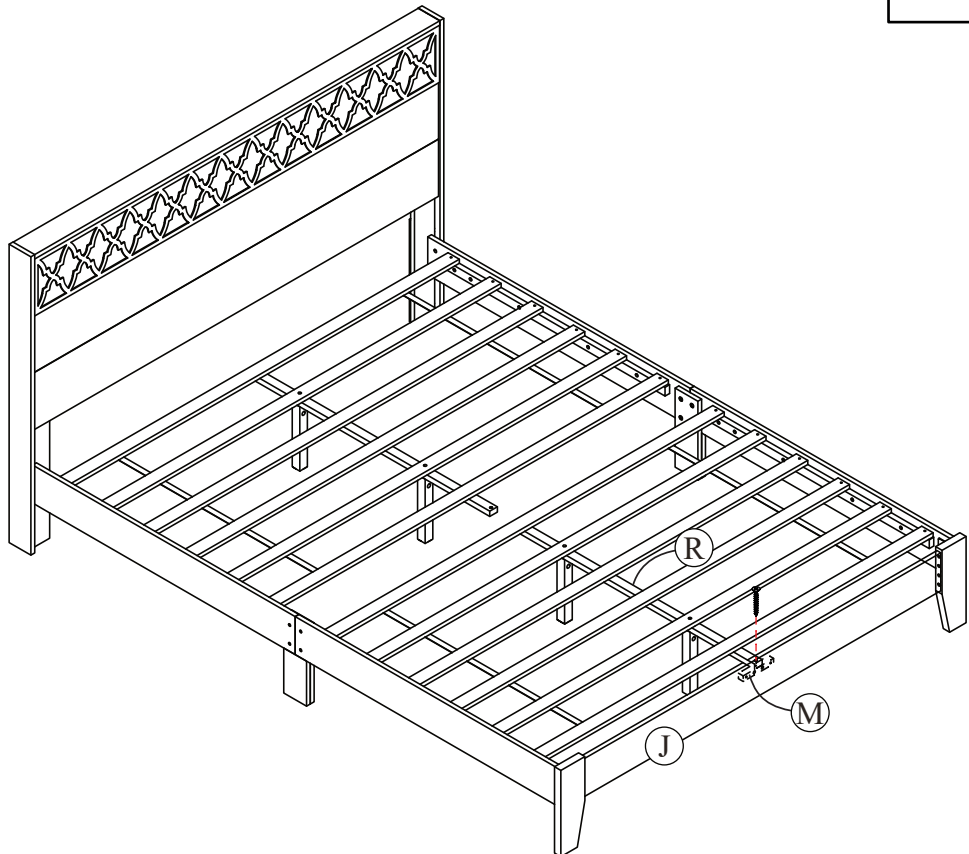
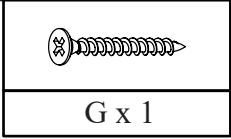

MAXIMUM LOADS CHARGES MAXIMALES / CARGA MAXIMA

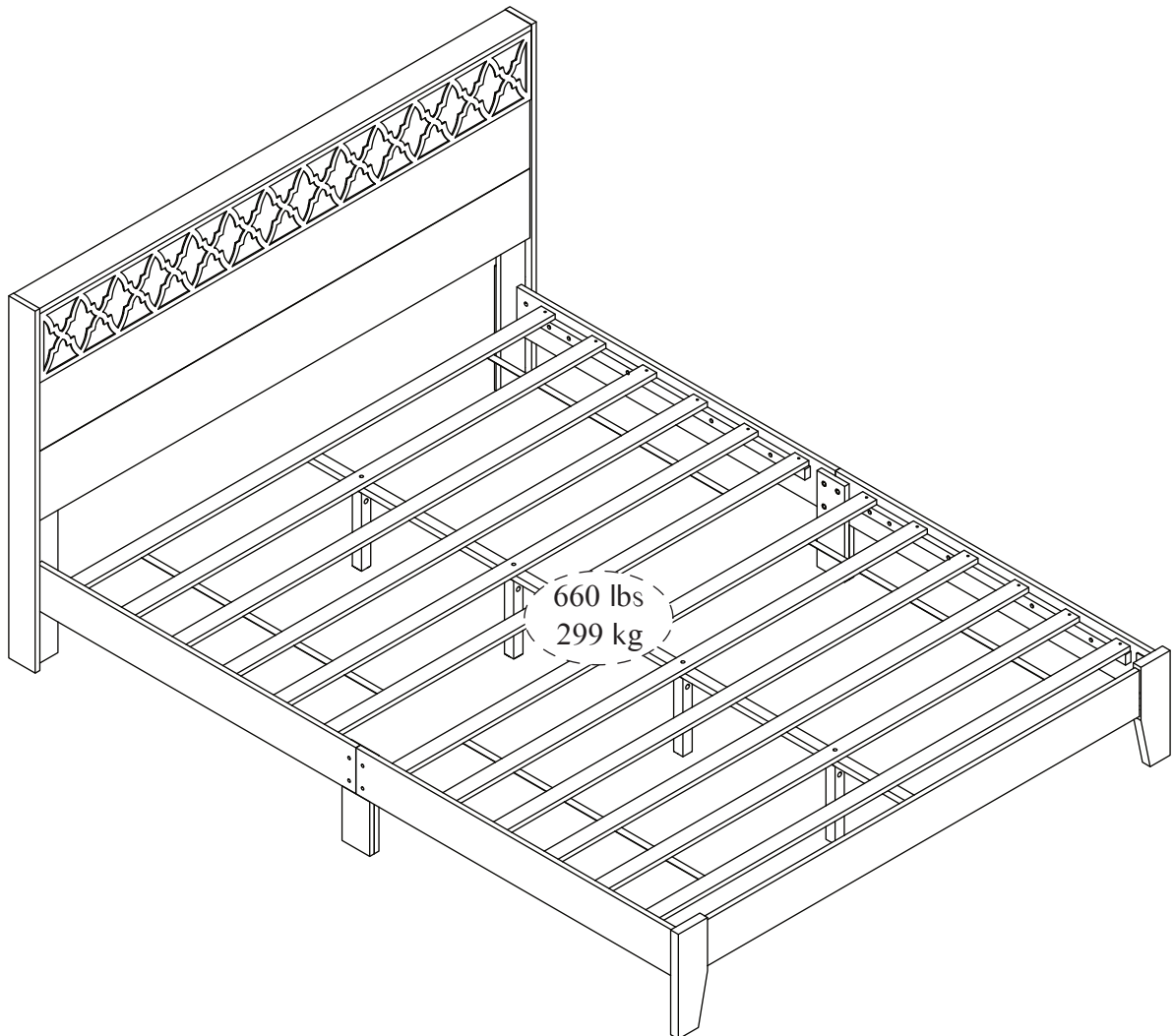

This unit has been designed to support the maximum loads shown. Exceeding these load limits could cause sagging, instability, product collapse, and/or serious injury.

Ce meuble a été conçu pour supporter les charges maximales indiquées. En excédant ces limites de charge, le meuble pourrait devenir instable, s'effondrer, et/ou causer des blessures graves.

Esta unidad ha sido diseñada para soportar la carga máxima anotada. El exceder estos límites puede causar inestabilidad, colapsarse y/o causar serias lesiones.
