

ASSEMBLY INSTRUCTION

FULL BED

IMPORTANT SAFETY NOTICE READ CAREFULLY BEFORE BEGINNING ASSEMBLY!

- * Before you begin, please read the Assembly Instruction carefully, identify all the parts, and hardware included. Do Not skip any steps and follow the assembly steps in order.
- * Place parts on the carton while installing to prevent damage or scratches. Be sure to check all packing materials carefully for small parts may have come loose inside the cartoon during shipment. If parts are missing, contact the retailer from which your purchased the product to obtain any missing part. **DO NOT USE SUBTITUTE PART.**
- * Some steps may require two or more people, do not attempt by yourself as there is a risk injury.

NOTE: BOLT FURNITURE DISCLAIMS ANY LIABILITY FOR DAMAGES OR INJURIES WHICH MAY OCCUR DUE TO FAILURE TO PROPERLY FOLLOW ASSEMBLY INSTRUCTION, FAILURE TO PROPER ASSEMBLY OR FAILURE TO PROPERLY USE OF THE PRODUCT.

NOTE: YOUR UNIT MAY LOOK DIFFERENT IN APPEARANCE FROM THE ONE SHOWN IN THE ILLUSTRATIONS ON THIS INSTRUCTION SHEET.

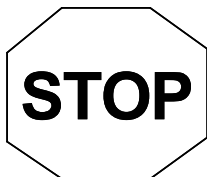
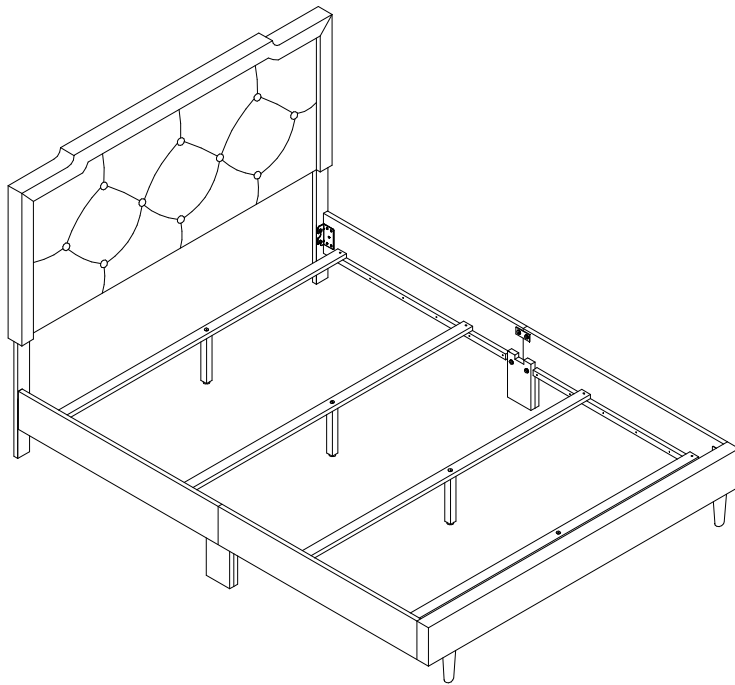

Required Tools : Screwdriver

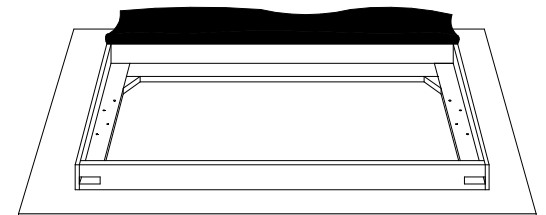
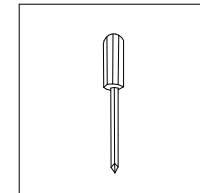

Please place on the carton while installing to prevent damage or scratches.

ASSEMBLY INSTRUCTION

FULL BED

ASSEMBLY PART

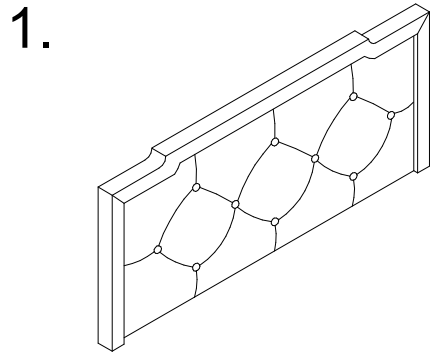

HEADBOARD PANEL

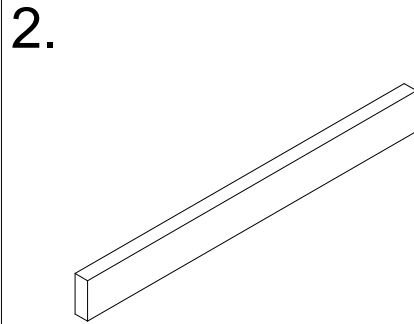

FOOTBOARD PANEL

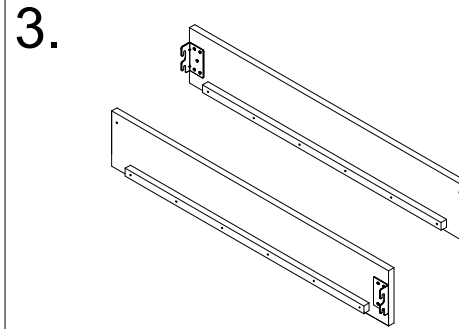

SIDE RAIL RIGHT (2PCS)

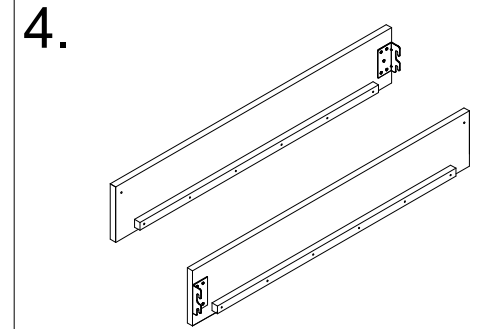

SIDE RAIL LEFT (2PCS)

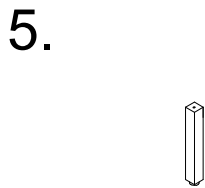

SUPPORT LEG (4PCS)

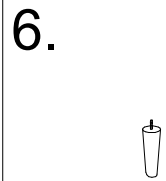

FOOTBOARD LEG (2PCS)

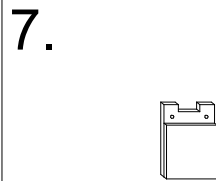

SIDE RAIL LEG (2PCS)

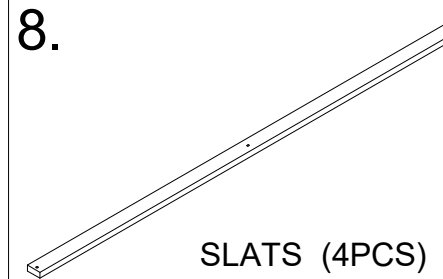



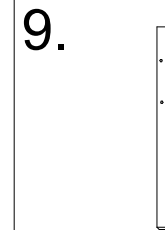



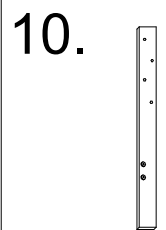

SLATS (4PCS)



HEADBOARD LEFT LEG



HEADBOARD RIGHT LEG

NO	HARDWARE DESCRIPTION	QTY
A.	Allen Key M4 	1PC
B.	Chipboard Screw M4 x 32mm 	8PCS
C.	JCBC Bolt M6 x 20mm 	4PCS
D.	JCBC Bolt M6 x 40mm 	16PCS
E.	Side Rail Connect 	2PCS
F.	Spring Washer 	20PCS
G.	Flat Washer 	20PCS
H.	Allen Key M5 	1PC

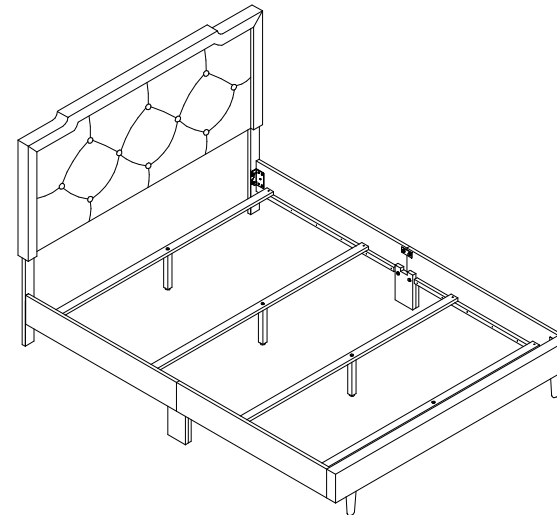



The headboard height is adjustable, before starting you must determine if you want to the headboard 42inch high, (for 42inc follow 1.1 for 47inc follow 1.2).

STEP 1.

Open the cover cloth located behind the Headboard (1) and attach the Right Leg (10) & Left Leg (9) use JCBC BOLT(D), Spring Wahser (F) & Flat Washer (G) & Allen Key M4 (A) to fix.

1.1

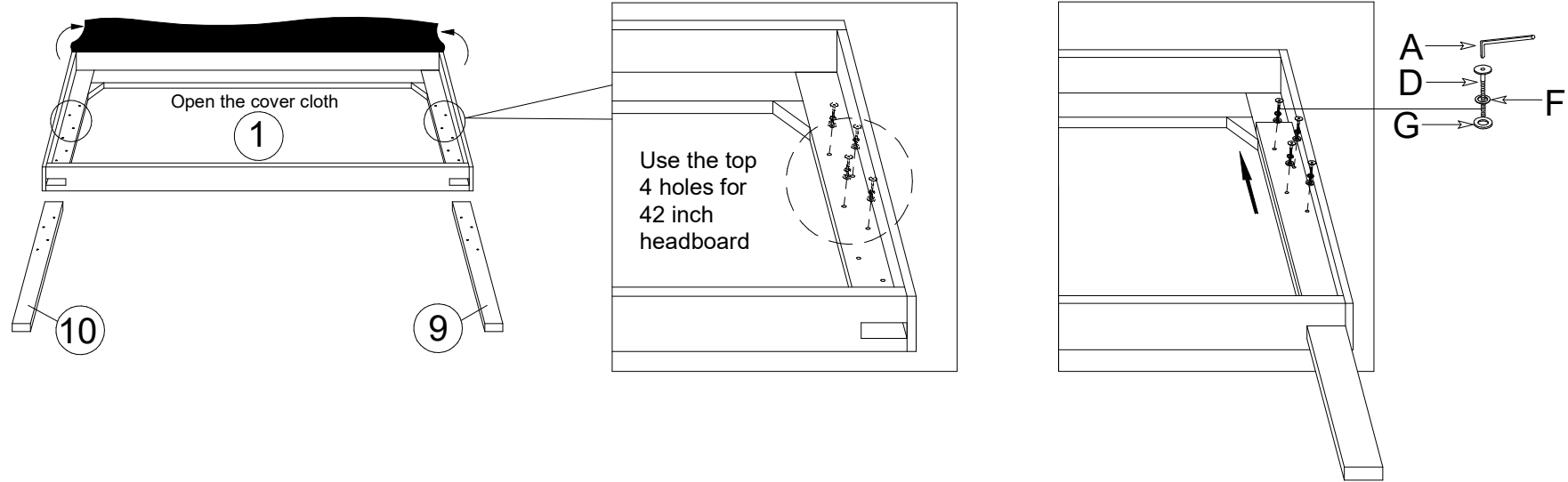

1.2

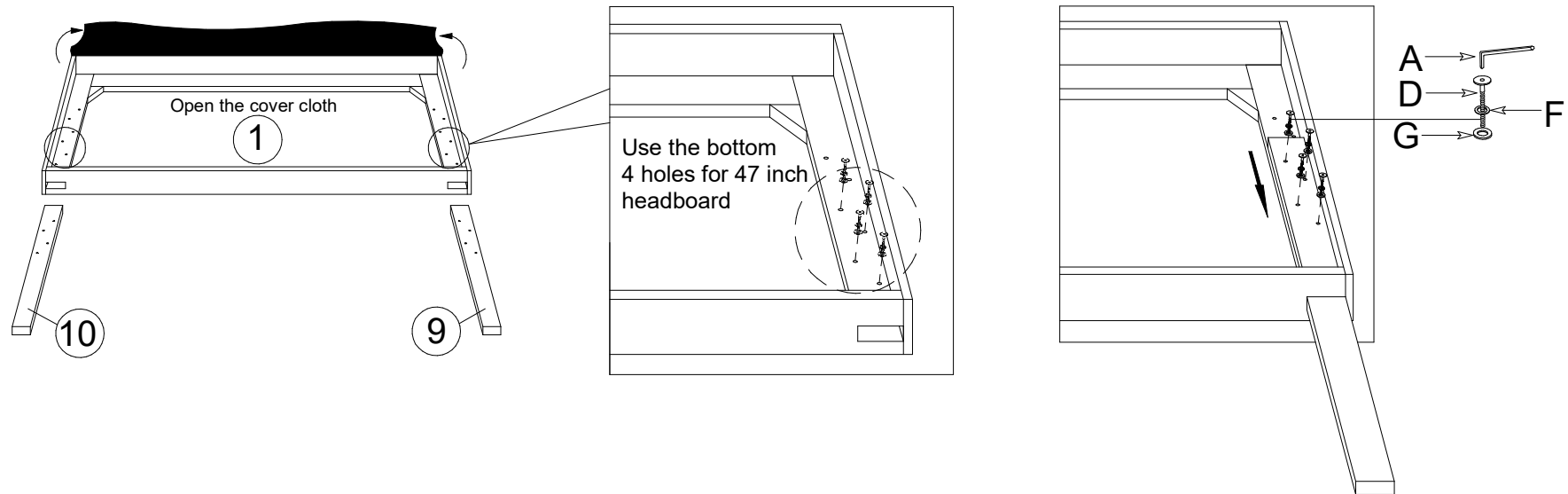

ASSEMBLY INSTRUCTION

FULL BED

STEP 2.

Attach the Slats (8) to Support Leg (5). JCBC Bolt (D), Spring Washer (F), Flat Washer (G) & Allen Key M4 (A) to fix.

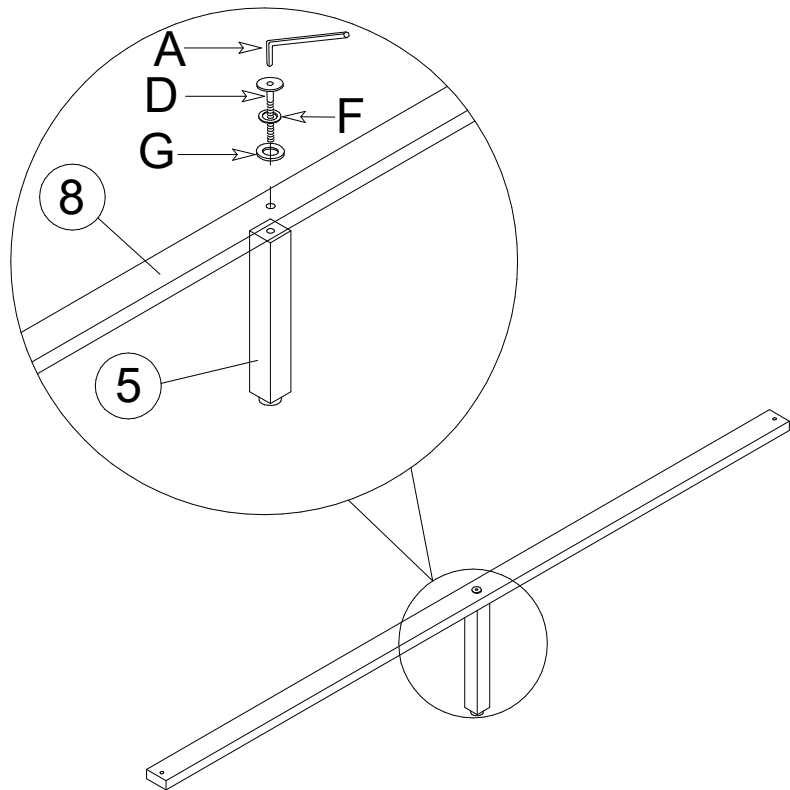

STEP 3.

Attach and tighten the Side Rail Right (3) (2pcs) & Side Rail Left (4) (2pcs) to Side Rail Leg (7) (2pcs.) Use JCBC Bolt (D), Spring Washer (F), and Side Rail Connect (E), Flat Washer (G) & Allen Key M4 (A) to fix.

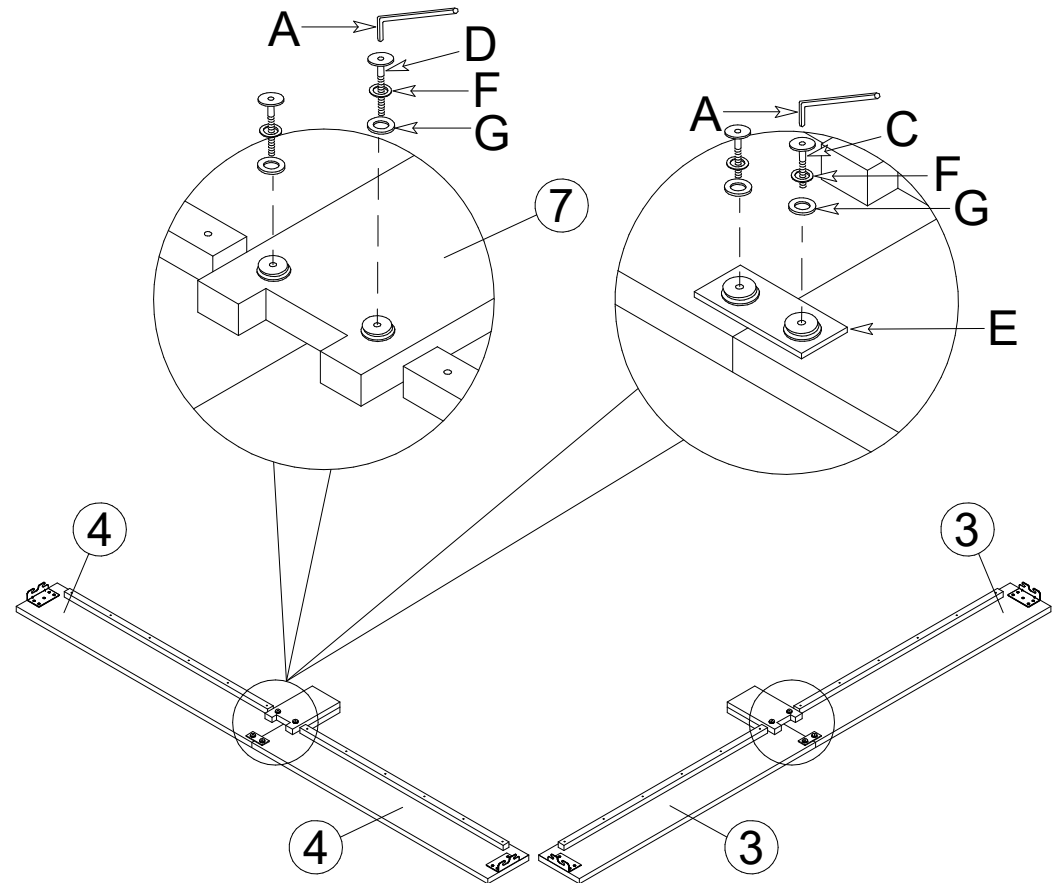

STEP 4.

Attached the Footboard Leg (6)(2pcs) to Footboard Panel (2).

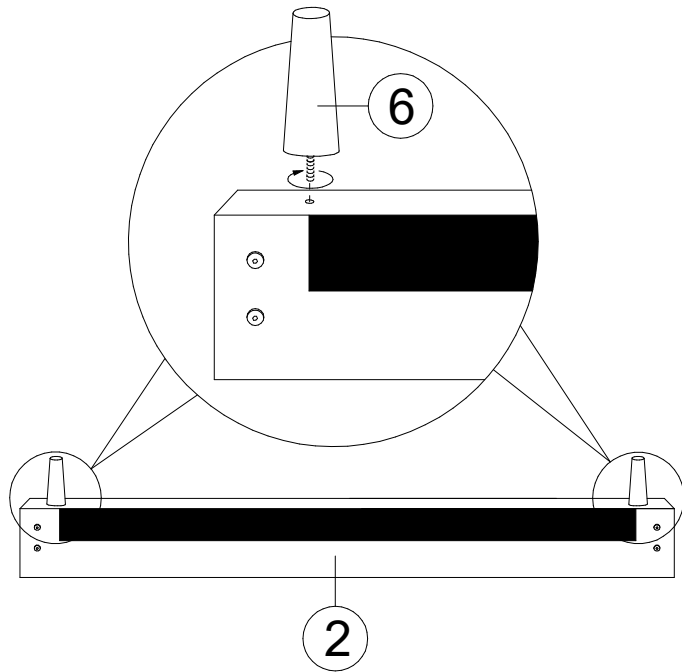

STEP 5.

Attach (hook) the Side Rail to Headboard Leg (1) & Footboard Panel (2).
Use JCBC Bolt & Allen Key M5 (H) to fix.

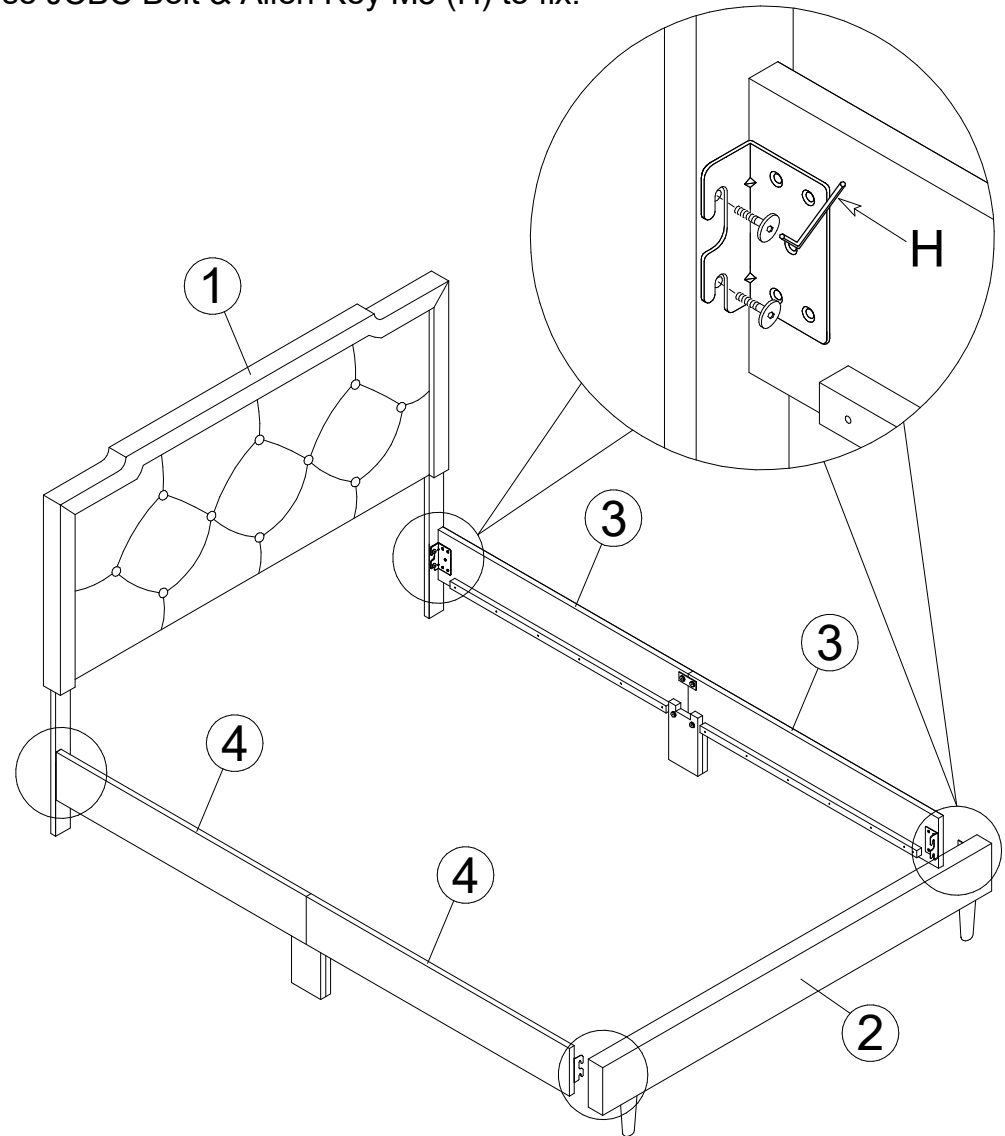

STEP 6.

Attach and tighten the Slats (8) to Side Rail. Adjusting the leg adjuster to the floor. Use screw M4 x 32mm (B) & screwdriver to fix.

