

INSTRUCTION MANUAL

58 inch TV cabinet

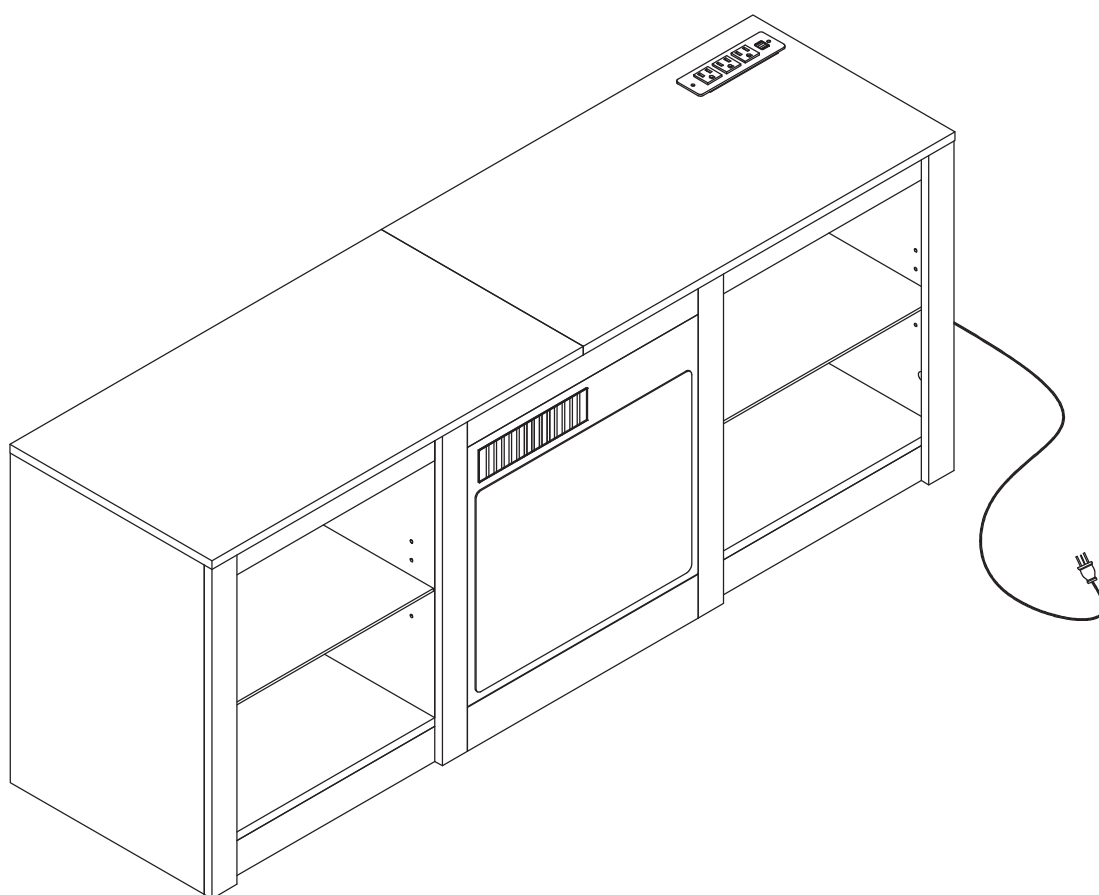

WELCOME TO THE FUTURE !

Thank you for choosing our new electric fireplace and TV stands! Our products are designed to be both stylish and functional, with a focus on energy efficiency and sustainability.

We use high-quality materials to ensure that our pieces are built last, so you can enjoy them for years. Whether you're looking for a cozy electric fireplace or a stylish TV stand, we have something for everyone.

Our products are perfect for any home or office, and we're confident that you'll love them as much as we do!

NOTICE

- 1.Children are not allowed to operate
2. Faster installation is possible with power tools.
3. Do not pull the door vigorously to prevent the storage cabinet from tipping over.
- 4.Please attach the storage cabinet to the wall with an anti-tip device after installation is complete.
5. When using the storage cabinet for the first time,please keep it in a ventilated environment to allow the smell to fully evaporate.
- 6.When placing the partitions,please make sure the nails are firmly installed to prevent the partitions from falling off.
7. If any parts are missing,broken,damaged or worn,discontinue use of the product until repairs are made and/or factory replacement parts are installed
8. Do not use this product in a manner inconsistent with the manufacturer's instructions as this may void the product warranty
- 9.If accessories are missing, please contact customer service for communication in time, we provide 7x24 hours after-sales service
- 10.Do not use any attachments or accessories other than the original factory attachments and accessories
- 11.Do not alter this equipment. Any alteration will create a safety hazard.

BEFORE YOU START

- ⚠ Please read all instructions carefully.
- ⚠ Retain instructions for future reference.
- ⚠ Separate and count all parts and hardware.
- ⚠ Read through each step carefully and follow the proper order.
- ⚠ We recommend that, where possible, all items are assembled near to the area in which they will be placed in use, to avoid moving the product unnecessarily once assembled.
- ⚠ Always place the product on a flat, steady and stable surface.
- ⚠ Keep all small parts and packaging materials for this product away from babies and children as they potentially pose a serious choking hazard.

PRE-INSTALLATION

GRAB YOUR TOOLS



Phillips Screwdriver



2 Persons Assembly



Up to 30 Minutes For Assembly

WHAT'S IN THE BOX

1

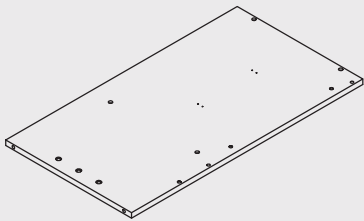

1PCS

2

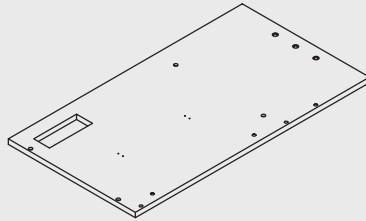

1PCS

3

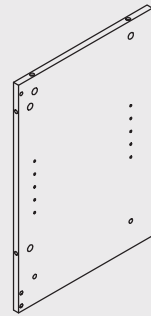

1PCS

4

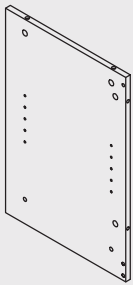

1PCS

5

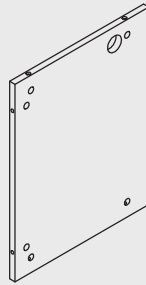

PCS

6

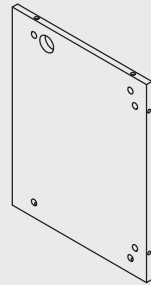

1PCS

7

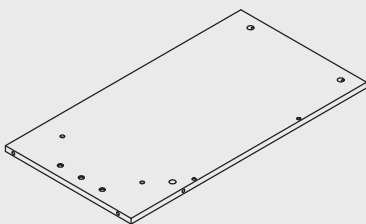

1PCS

8

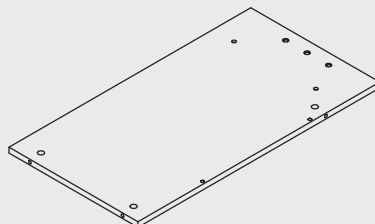

1PCS

9



1PCS

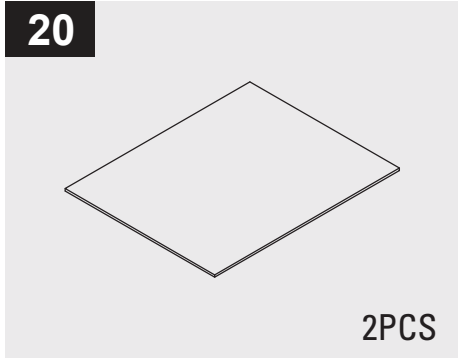
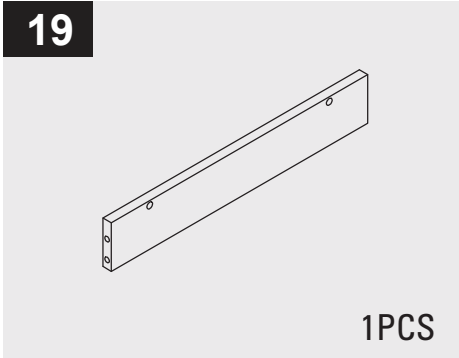
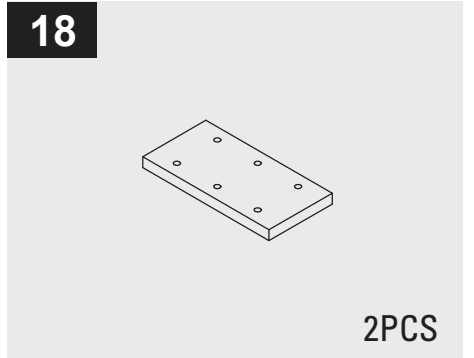
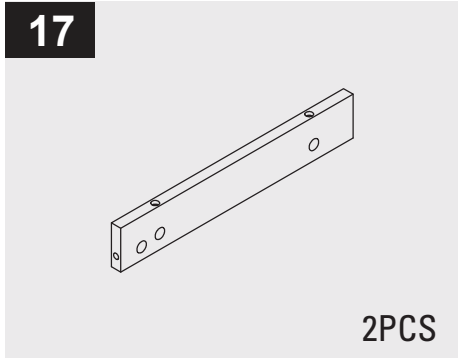
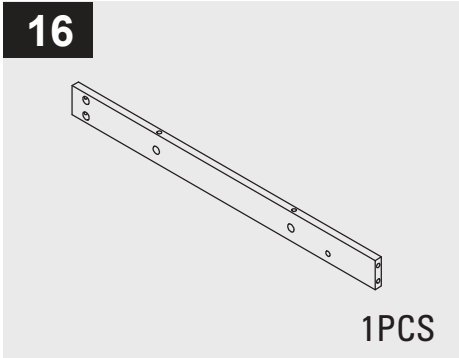
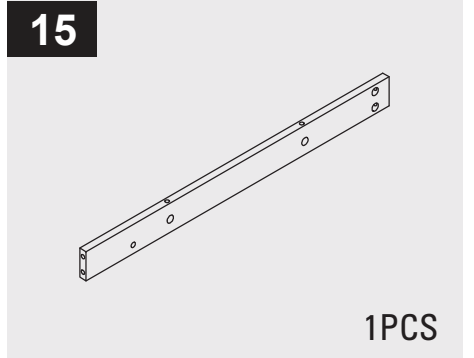
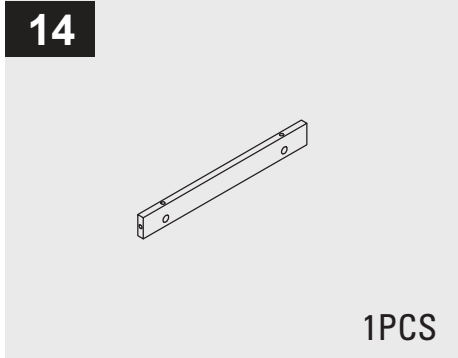
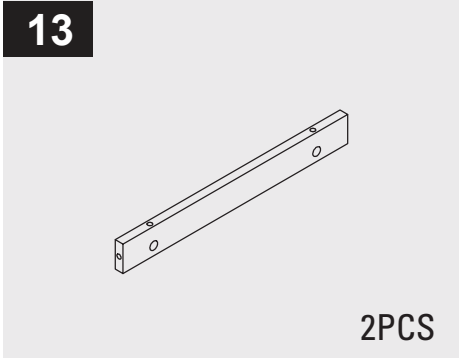
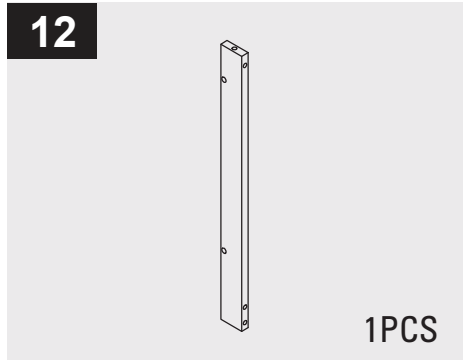
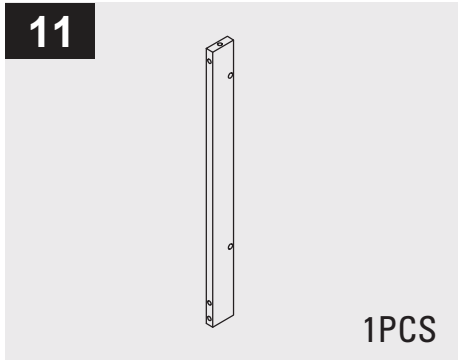
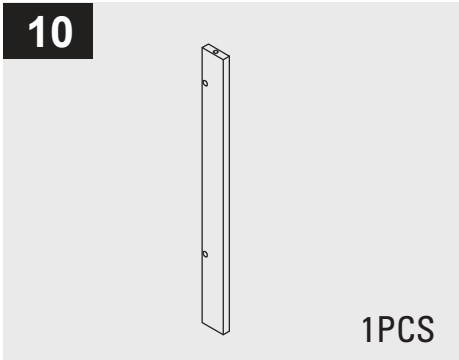

HARDWARE

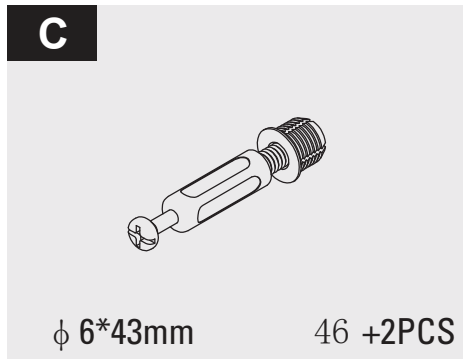
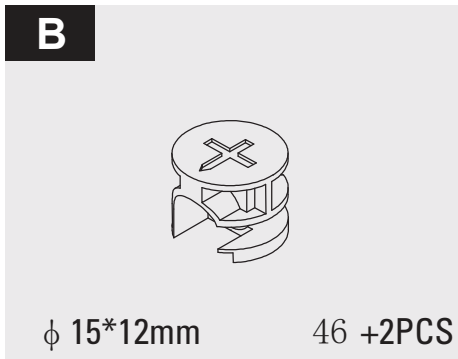
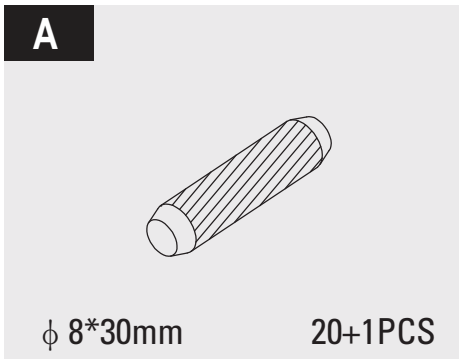

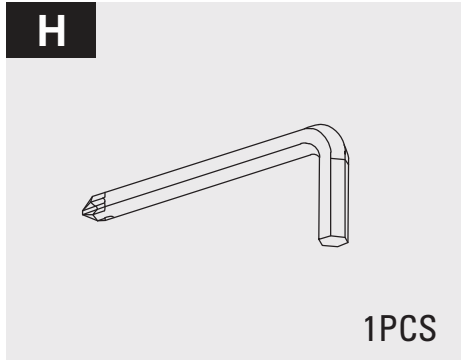
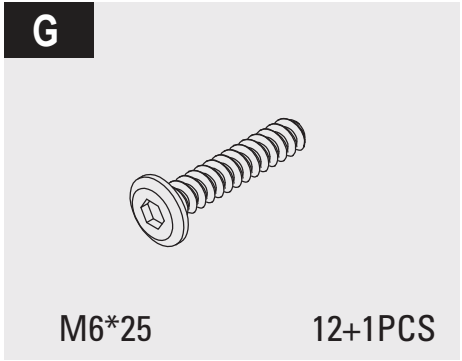
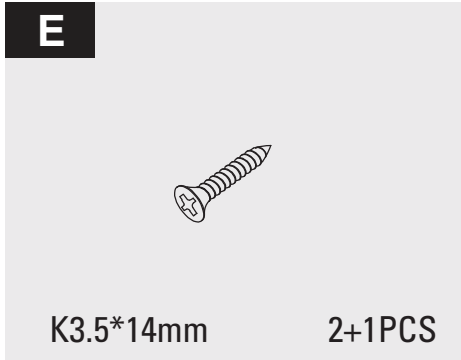
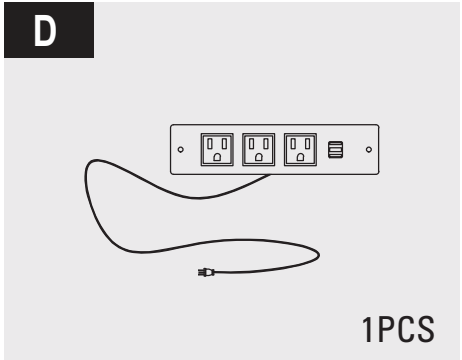

PRODUCT ASSEMBLY

STEP 1

Press down the 8 "C" into the corresponding holes until the white plastic thread is completely inserted in the middle. Then turn the screw clockwise.

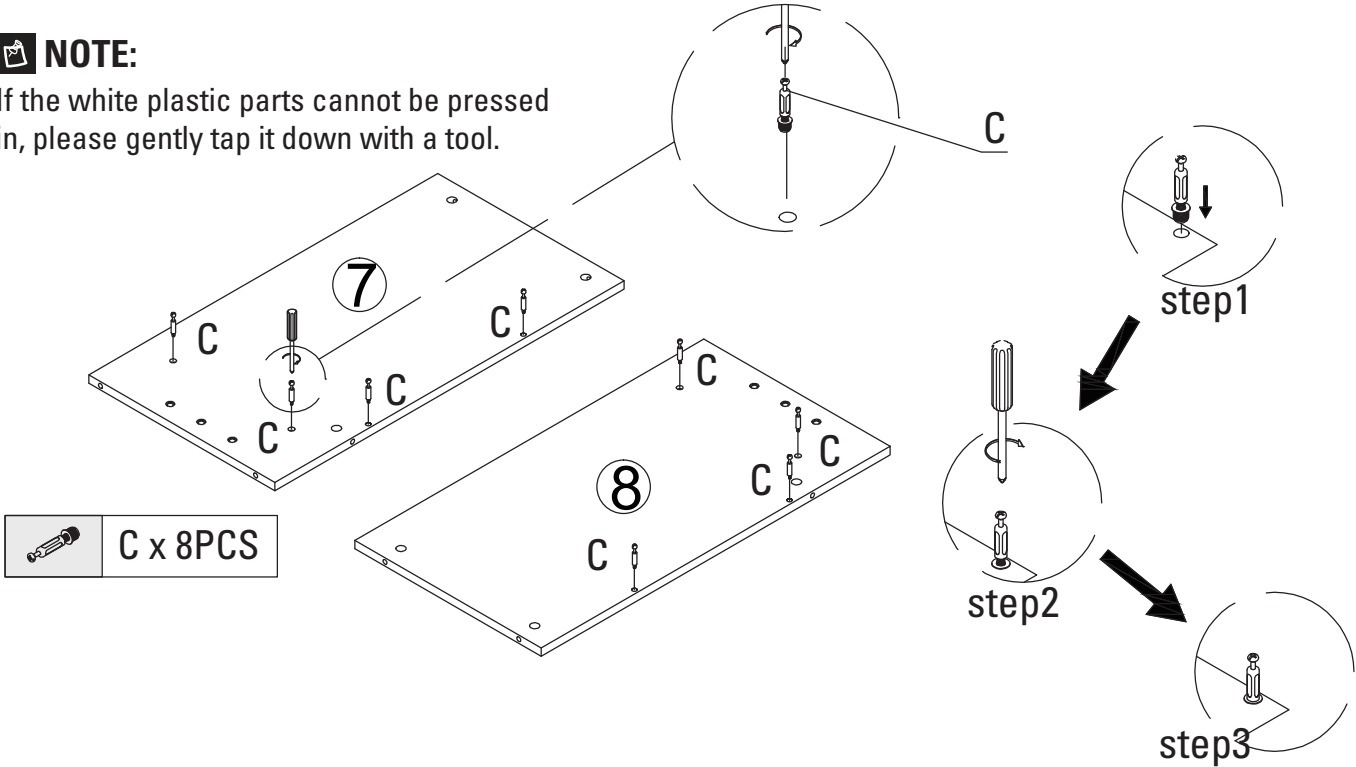

NOTE:
If the white plastic parts cannot be pressed in, please gently tap it down with a tool.



PRODUCT ASSEMBLY

STEP 2

Connect ⑦ and ⑧ with two "A", then connect ⑱ and ⑦, ⑧ with 6 screws "G".

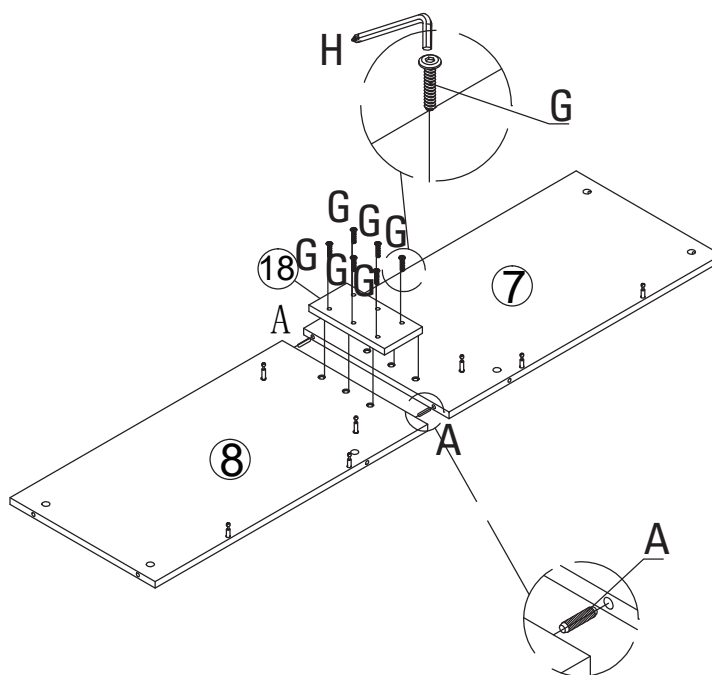

	A x 2PCS
	G x 6PCS

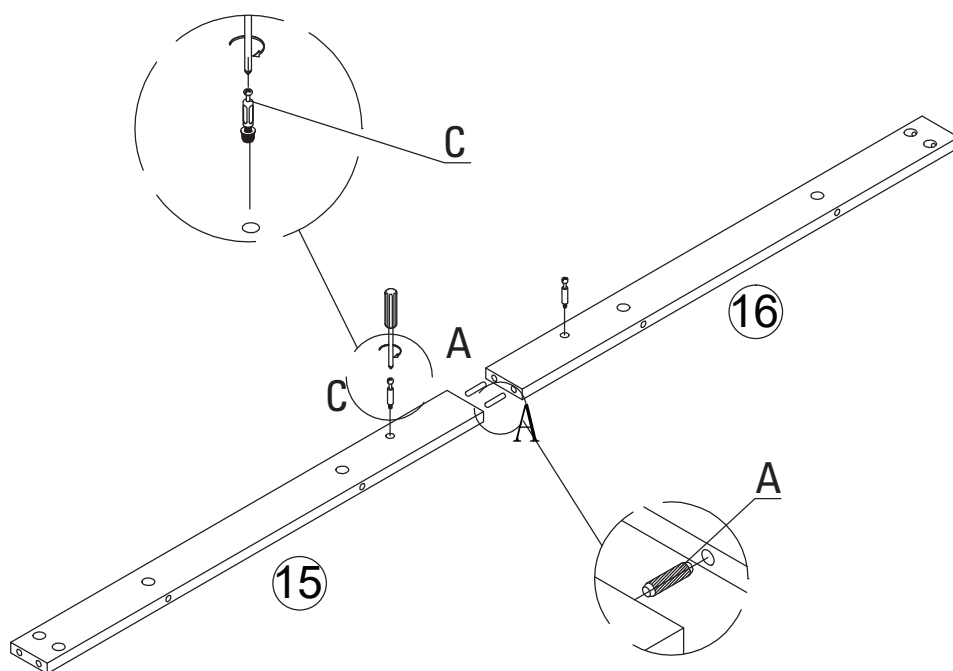

STEP 3

Connect ⑮ and ⑯ with two "A", Install two "C" into the hole corresponding to ⑮ and ⑯.



	A x 2PCS
	C x 2PCS

PRODUCT ASSEMBLY

STEP 4

Connect ⑮ / ⑯ and ⑰ with two "B". Lock them clockwise.

 B x 2PCS

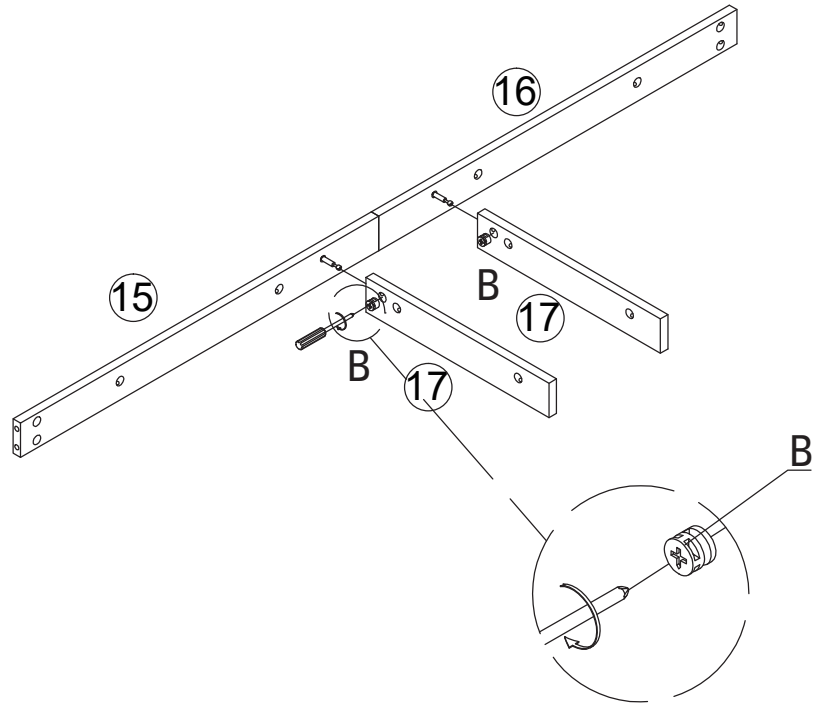

STEP 5

Use 4 "B" to connect ⑮ / ⑰ and ⑦, and use the same method to connect ⑯ / ⑰ and ⑧ with 4 "B".

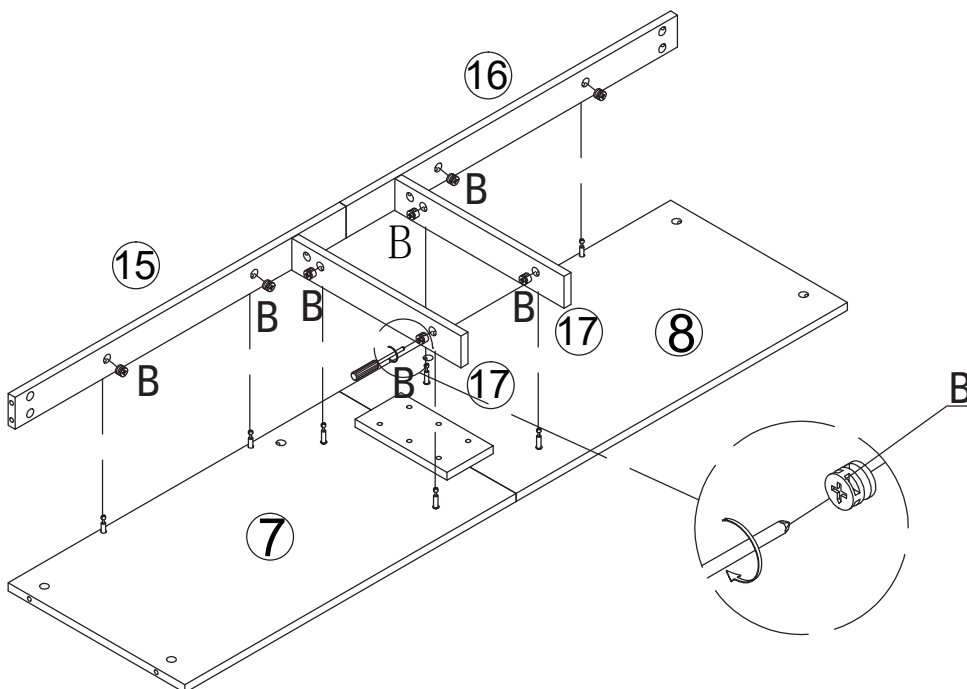

 B x 8PCS

PRODUCT ASSEMBLY

STEP 6

Press down the 4 "C" into the corresponding holes corresponding to ⑨ and ⑩ until the white plastic thread is completely inserted in the middle. Then turn the screw clockwise.

 C x 4PCS

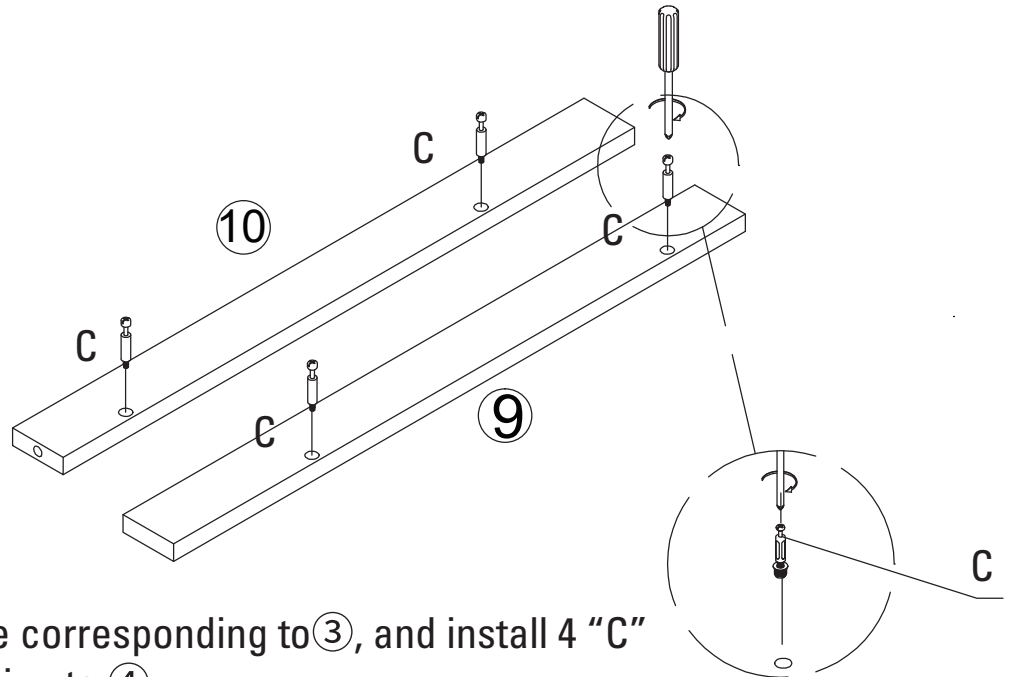

STEP 7

Install 4 "C" into the hole corresponding to ③, and install 4 "C" into the hole corresponding to ④.

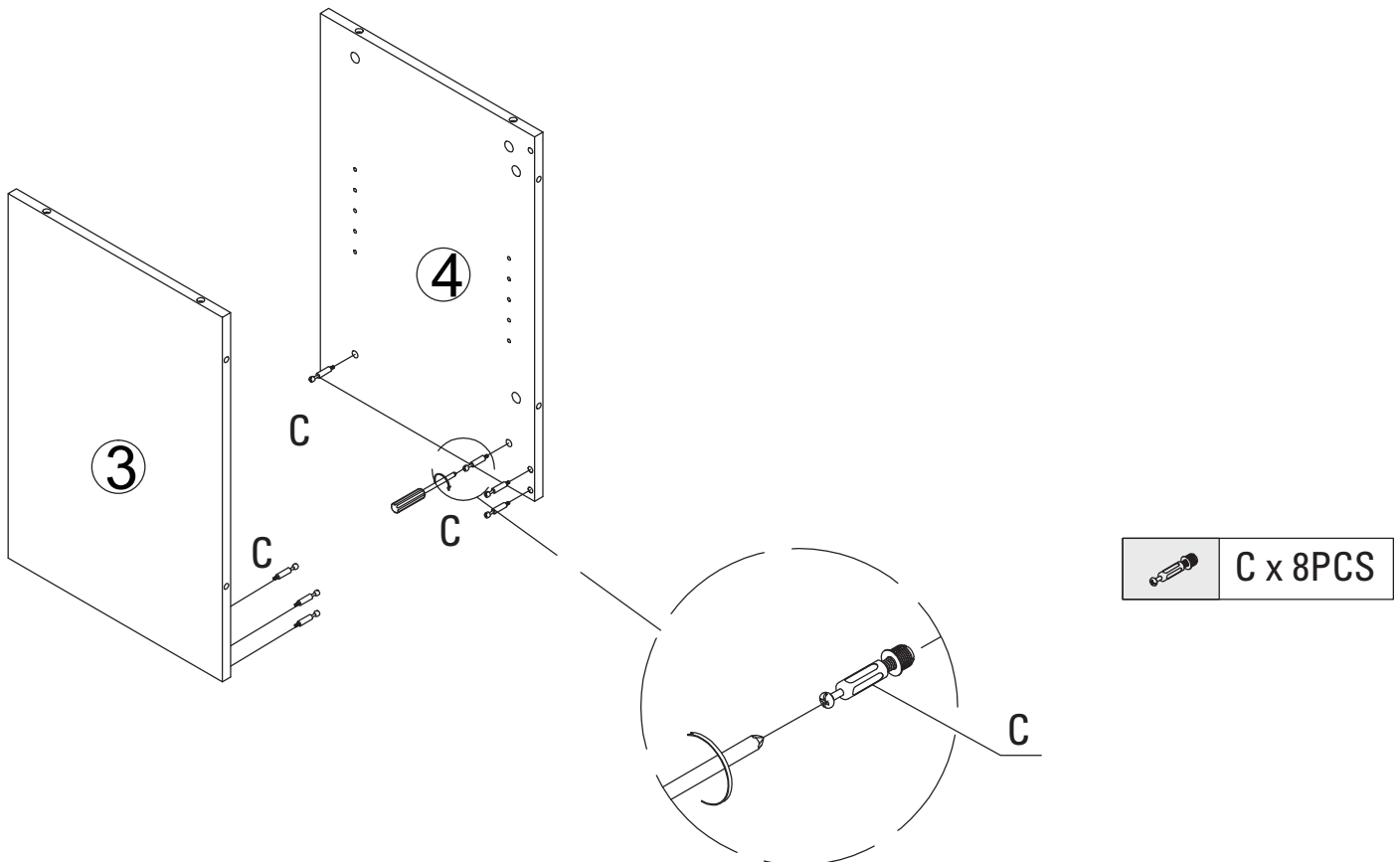

PRODUCT ASSEMBLY

STEP 8

Connect ③ and ⑨ with two "B", then use the same method to connect ④ and ⑩ with two "B".

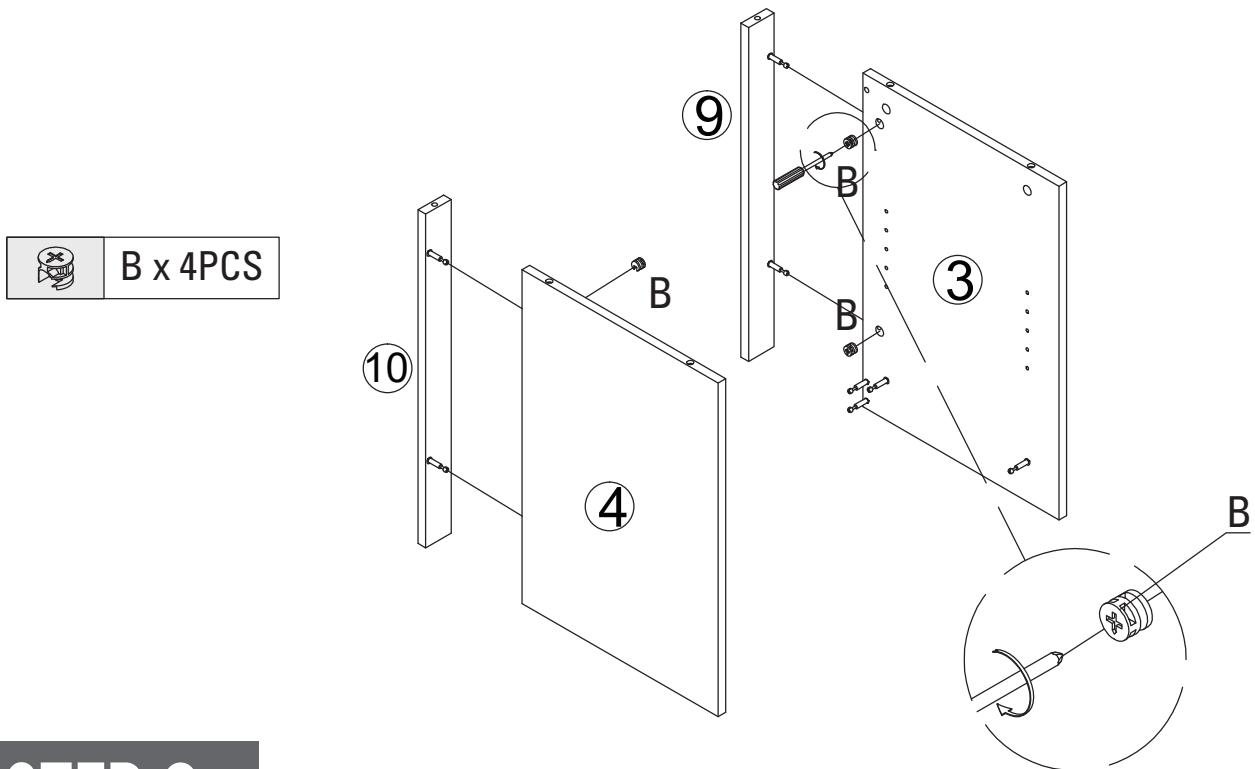

STEP 9

Install 4 "C" into the hole corresponding to the other side of the ⑦ and ⑧ boards that have been assembled in the step 5.

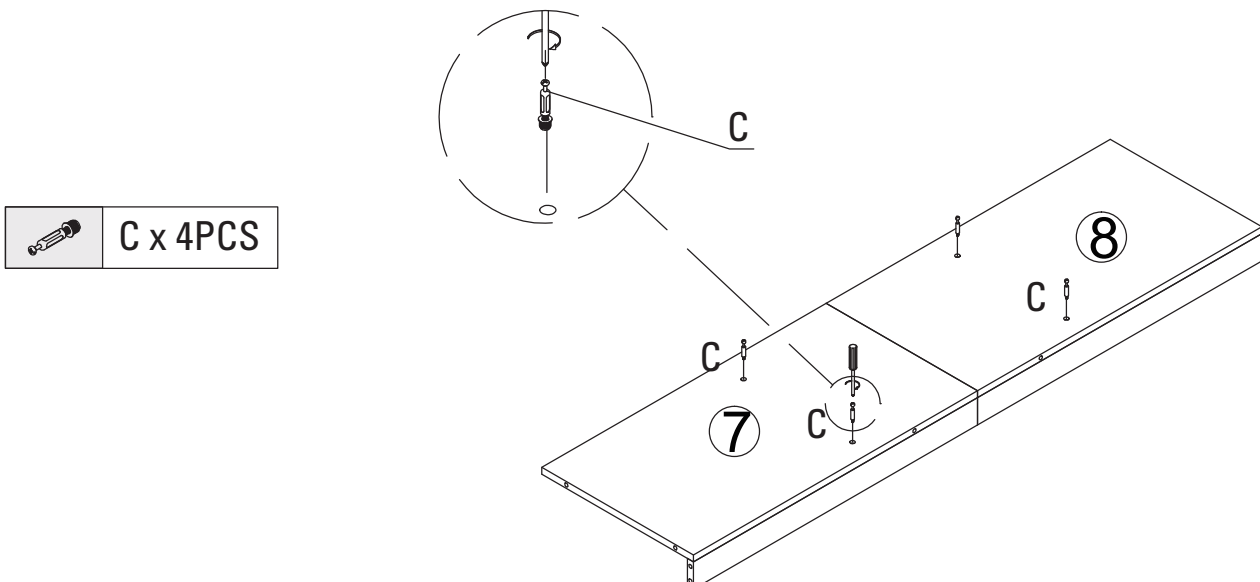

PRODUCT ASSEMBLY

STEP 10

Install 4 "C" into the hole corresponding to the other side of the ⑦ and ⑧ boards that have been assembled in the step 5.

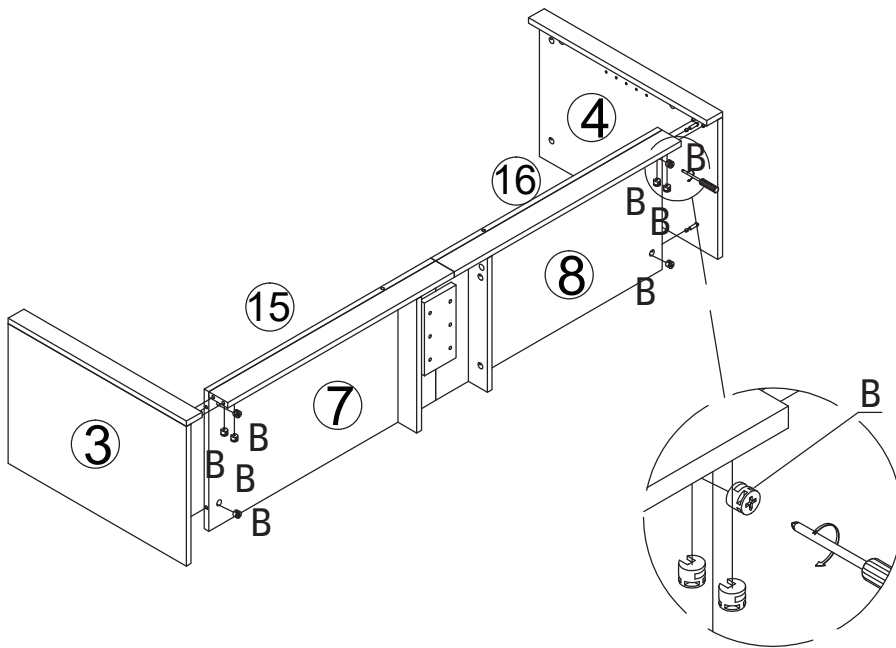

STEP 11

Place the parts assembled in the step 10 as shown in the picture below. Connect ⑬ and ⑤ with one "A", then connect ⑬ and ③ with one "A". Use 2 "B" to connect ⑤ and ⑦, lock them clockwise. Use the same method to connect ④ and ⑬, ⑥ and ⑬, and ⑥ and ⑧.

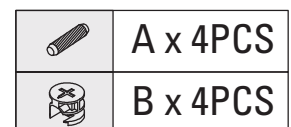
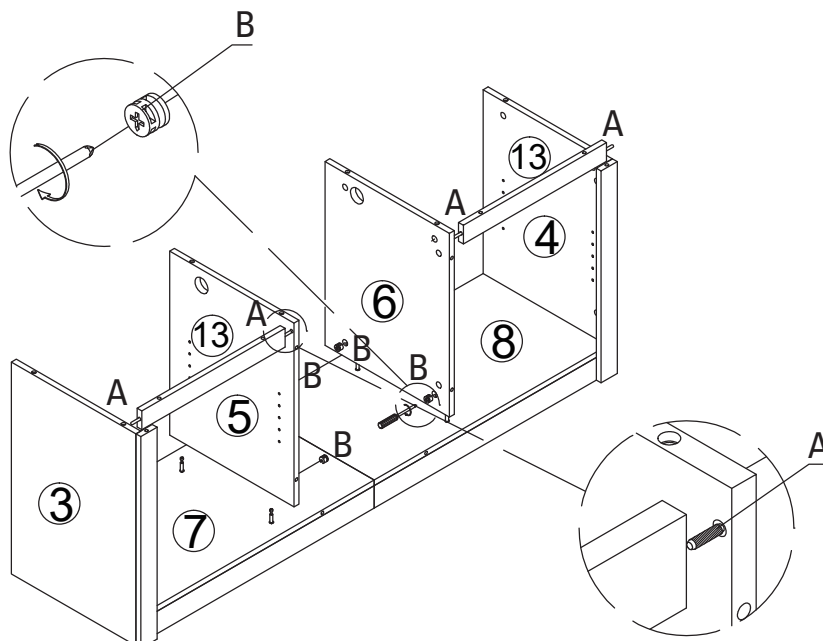

PRODUCT ASSEMBLY

STEP 12

Screw in two "C" into corresponding holes on ⑪/⑫/⑲.

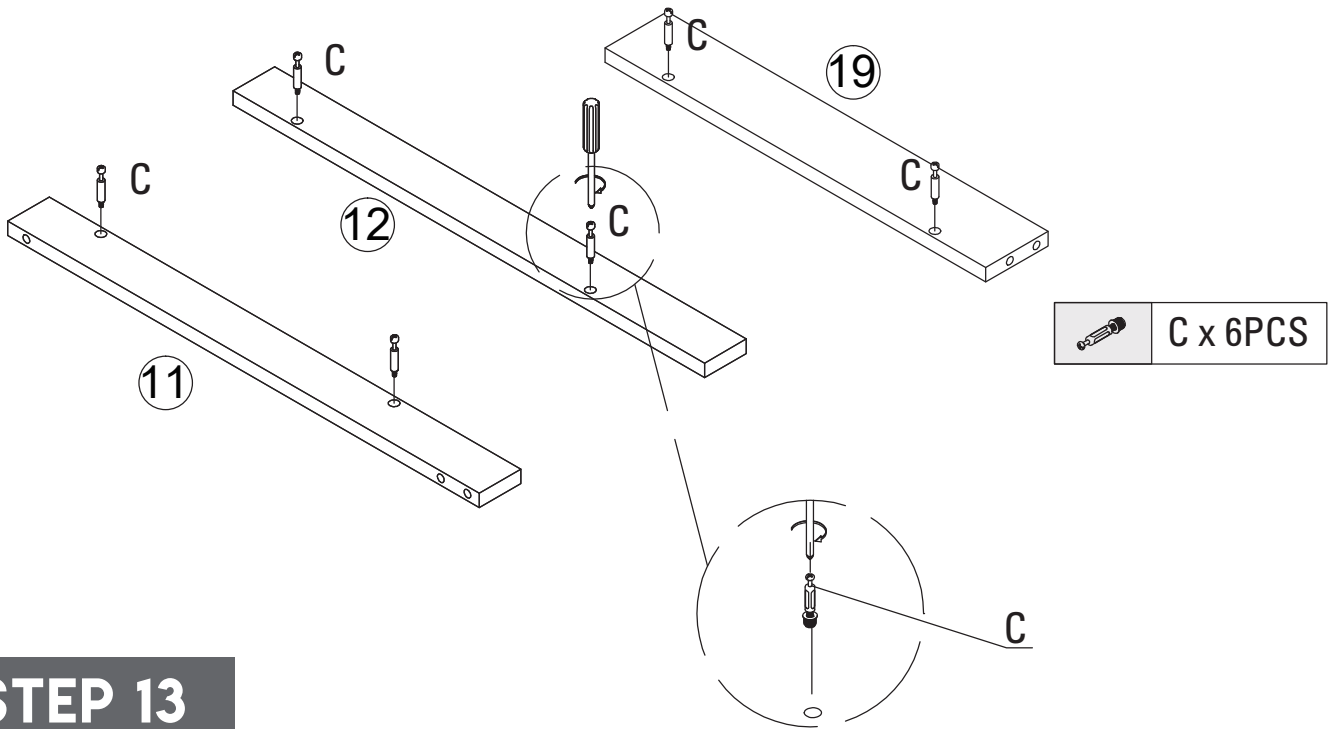

STEP 13

According to the installation diagram, connect ⑪, ⑭, ⑫, and ⑲ with 6 "A".

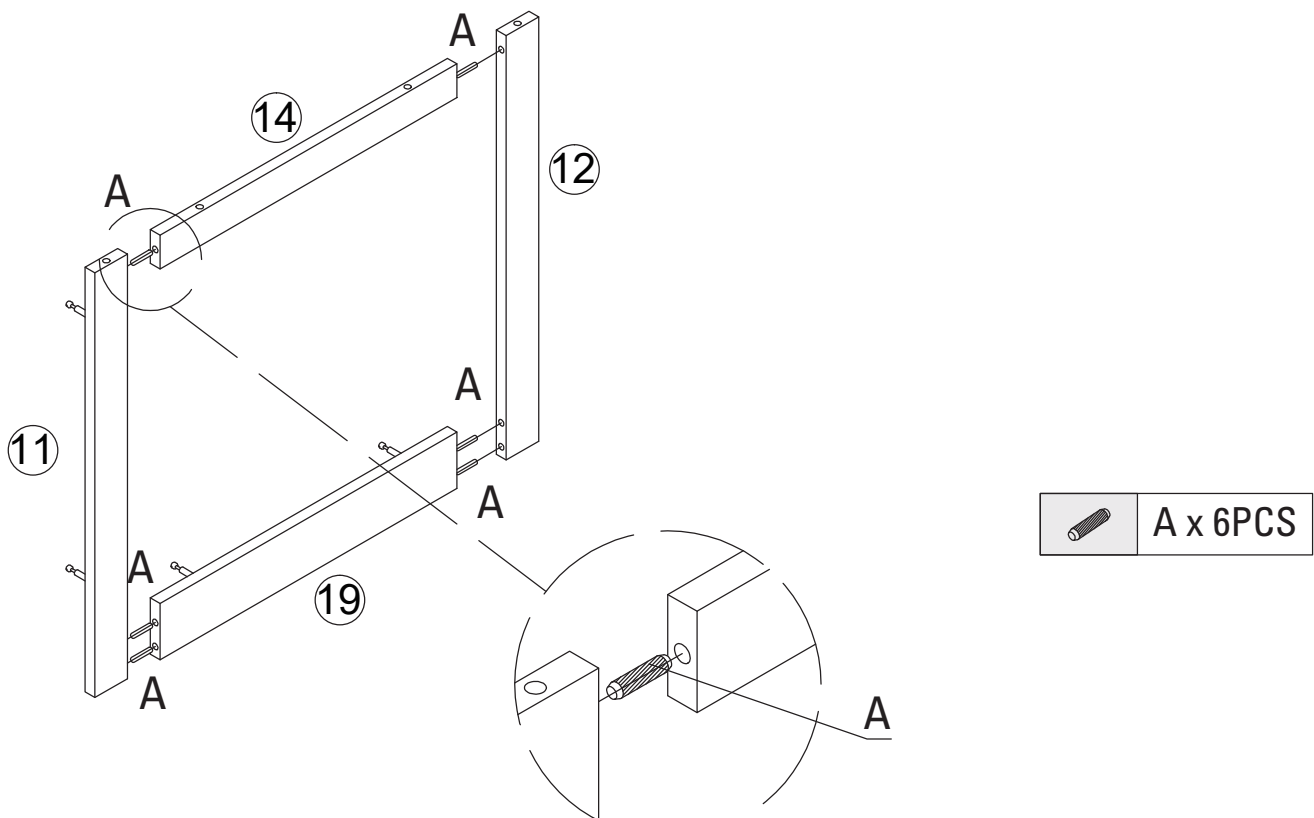

PRODUCT ASSEMBLY

STEP 14

Connect ⑭ and ⑫ with two "B". Then connect ⑪ and ⑤ with two "B", and connect ⑫ and ⑥ with two "B".

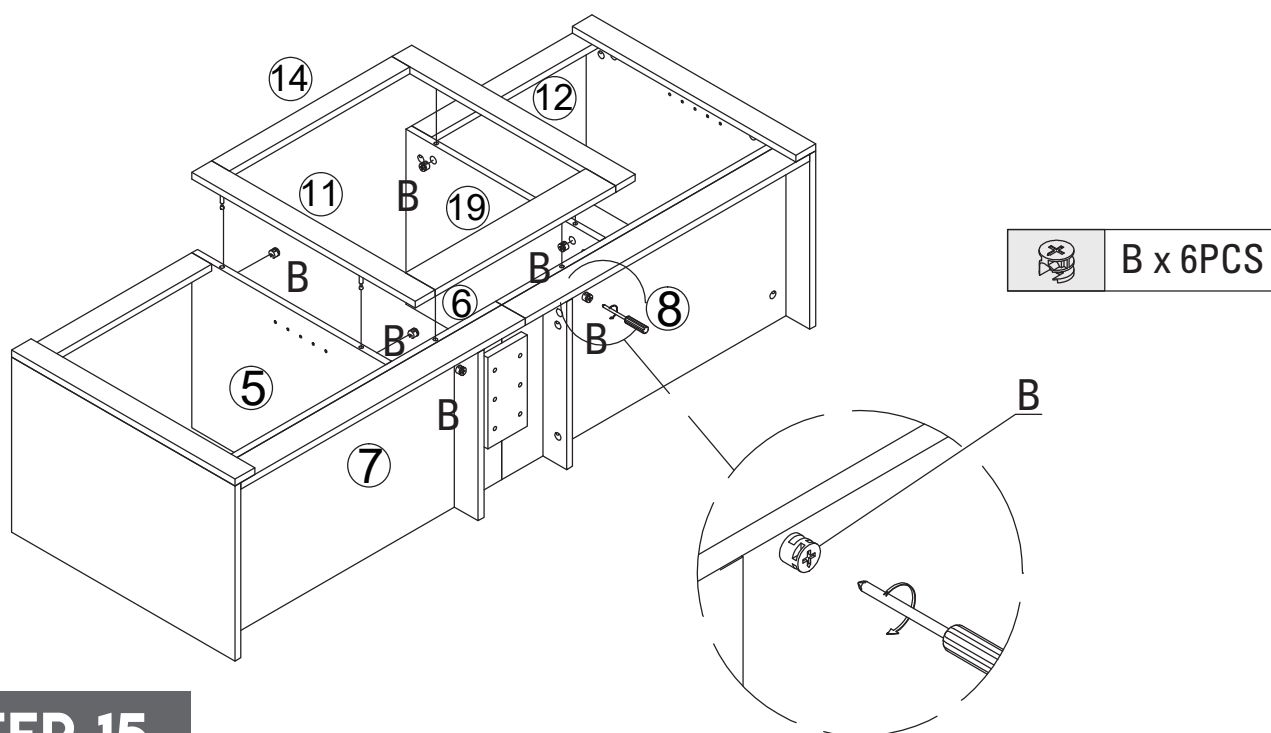

STEP 15

Install 7 "C" into the hole corresponding to ①/②.

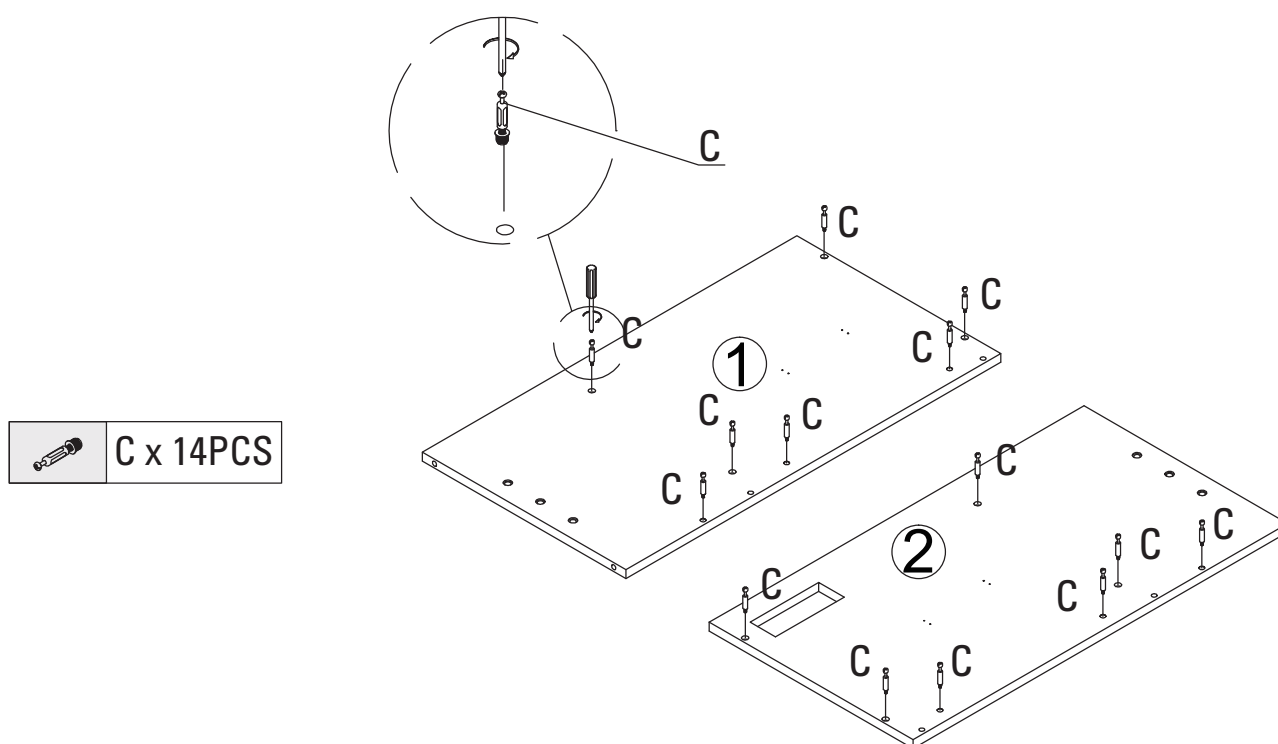



PRODUCT ASSEMBLY

STEP 16

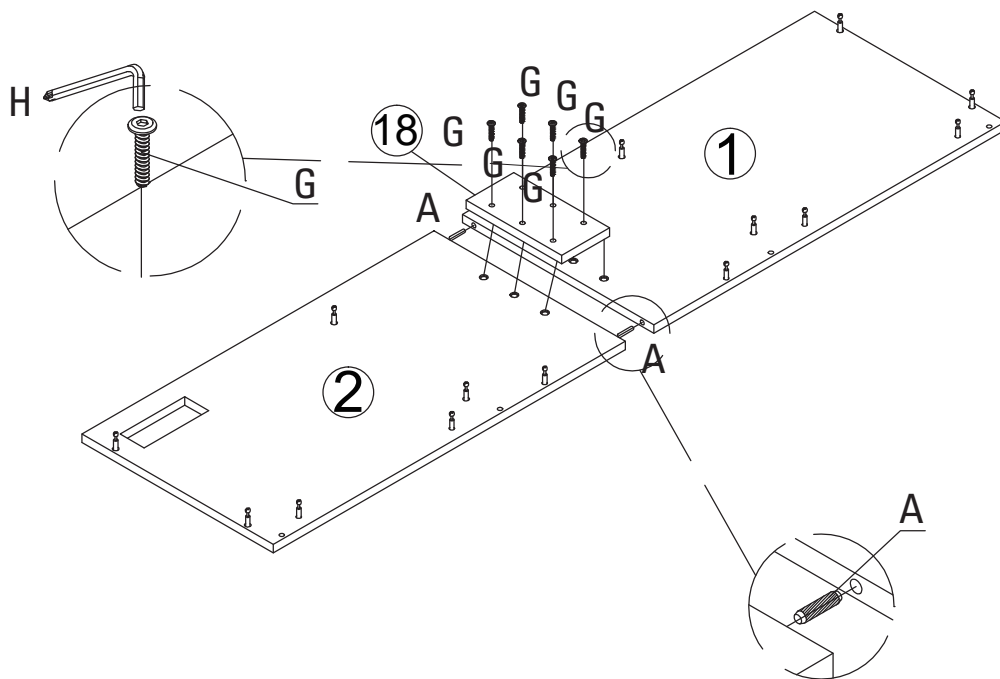
Connect ① and ② with two "A", then use 6 "G" to connect ⑱ with ① and ②.





	A x 2PCS
	G x 6PCS

PRODUCT ASSEMBLY

STEP 17

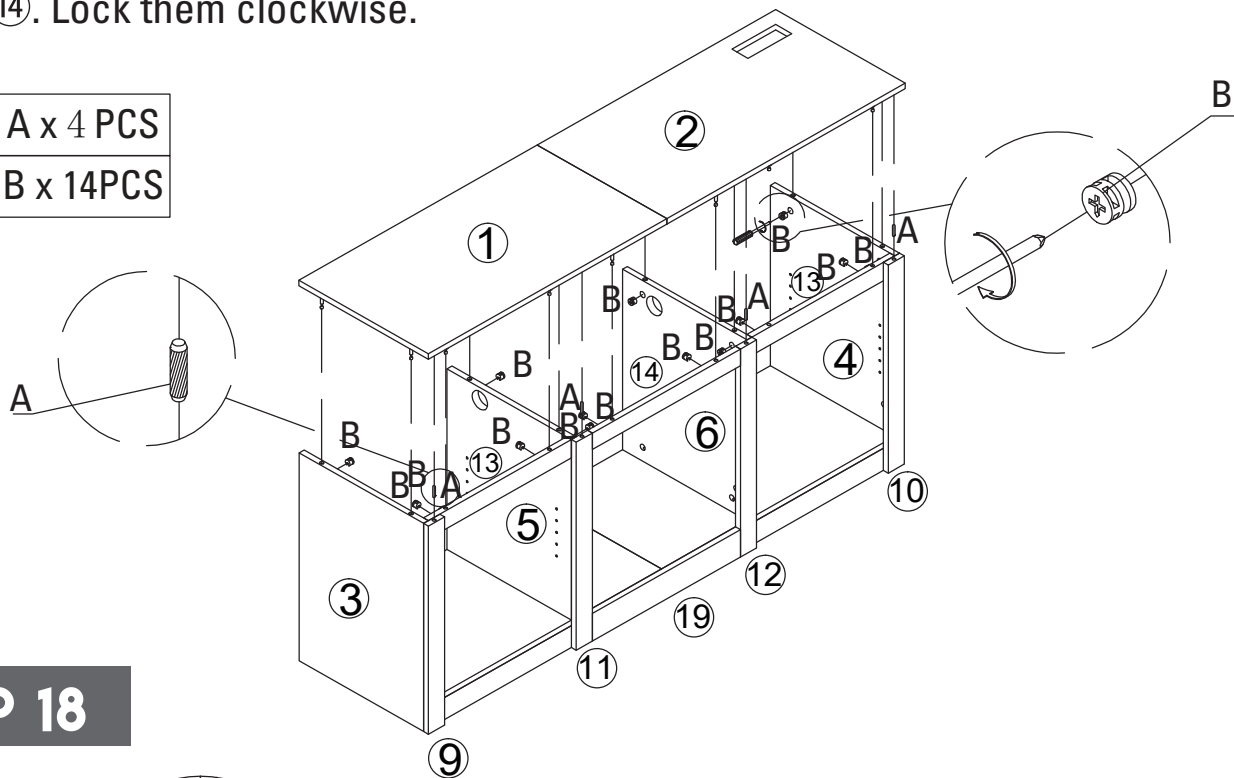

Insert two "A" into holes corresponding to both ⑨ and ⑪, insert two "A" into holes corresponding to both ⑫ and ⑩. Then place the top board at its corresponding position. Use 7 "B" to connect ① and ③/⑤/⑬/⑭, and use 7 "B" to connect ② and ④/⑥/⑬/⑭. Lock them clockwise.

	A x 4 PCS
	B x 14PCS

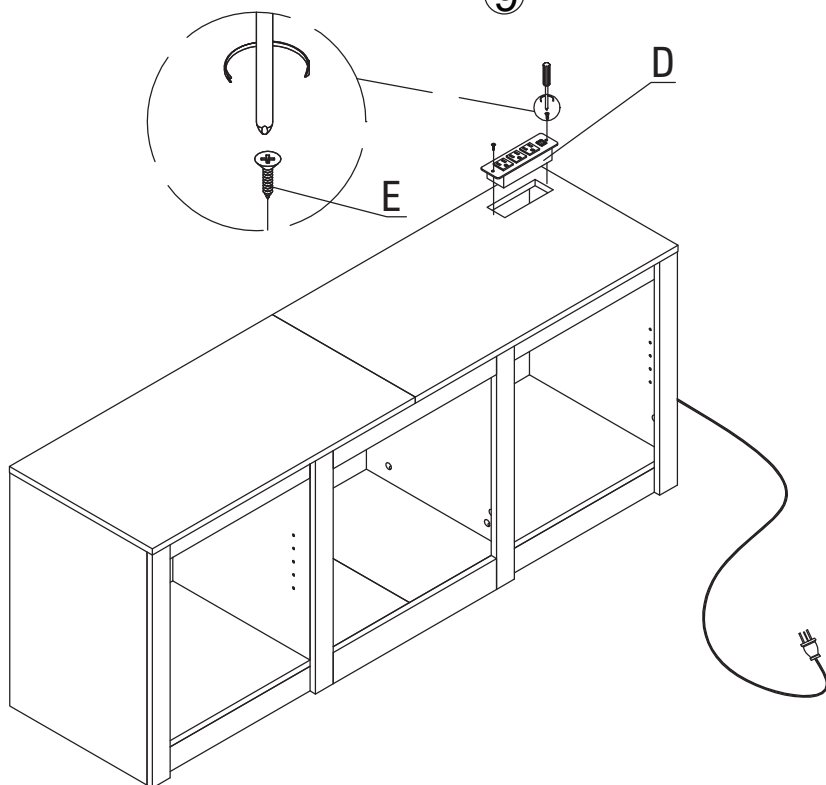

STEP 18



	E x 2PCS
	D x 1PCS

PRODUCT ASSEMBLY

STEP 19

Place the two glass shelves into the cabinet. You can adjust the height of the shelves.

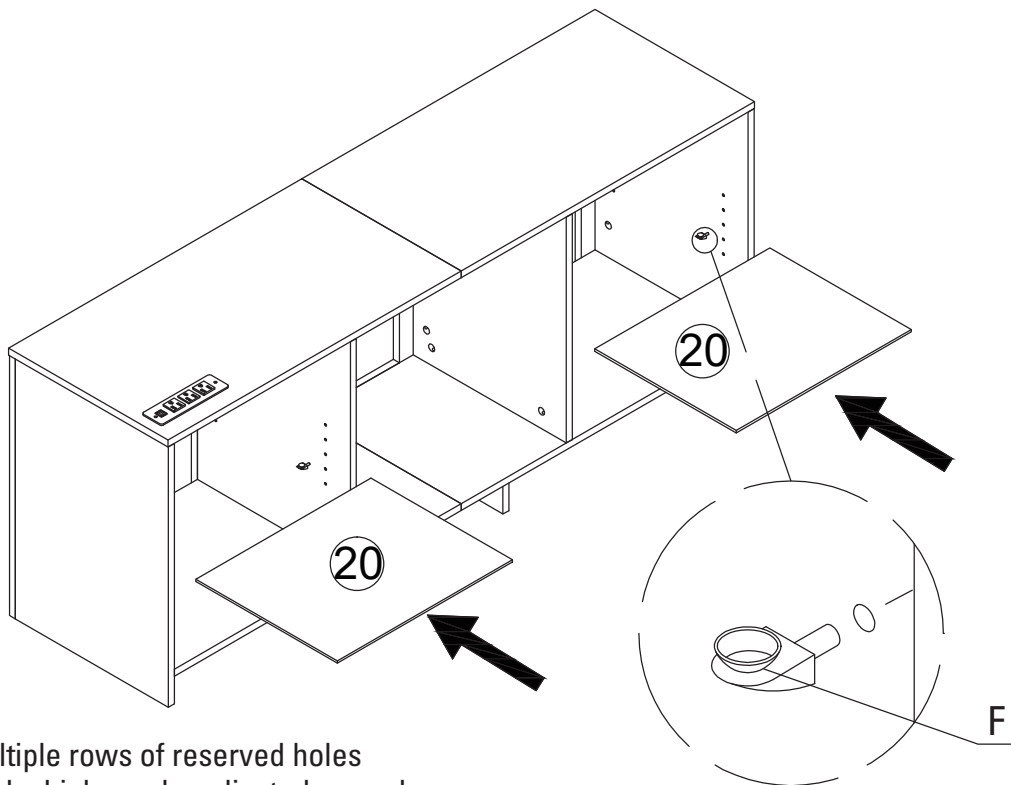

NOTE:

There are multiple rows of reserved holes on layer board which can be adjusted up or down.

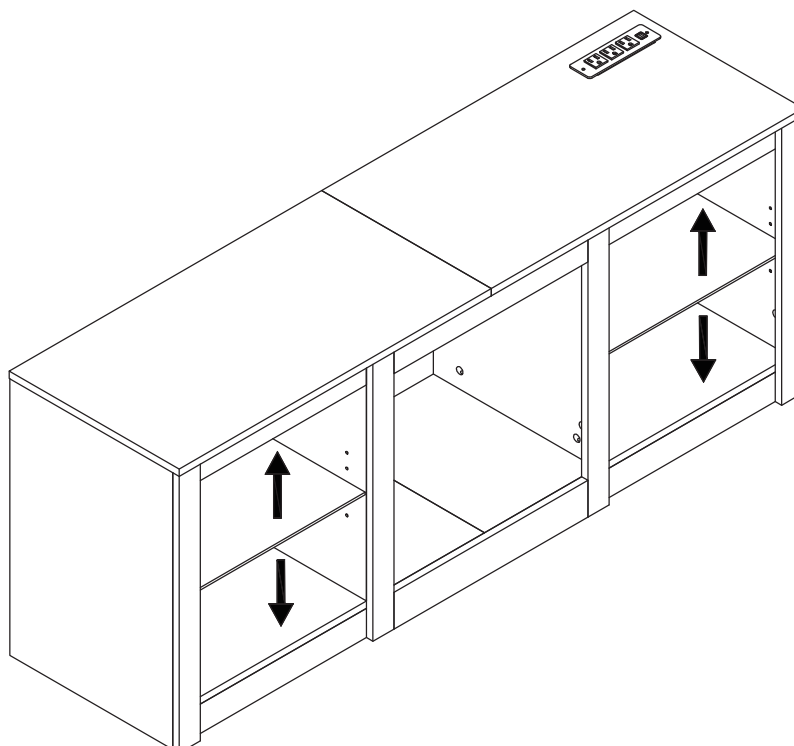

PRODUCT ASSEMBLY

STEP 20

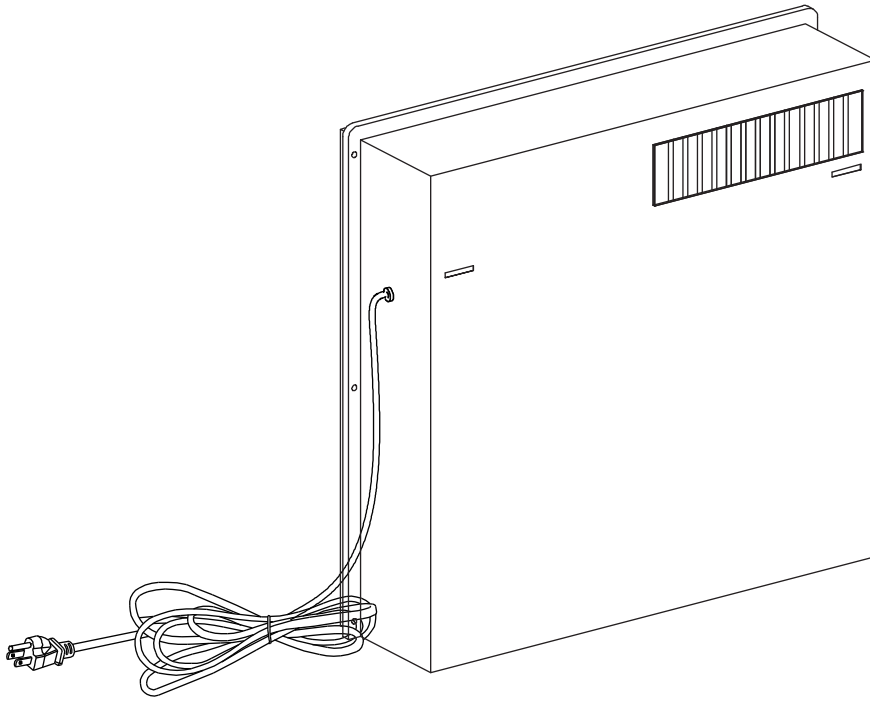

STEP 21

Put the fireplace into the cabinet from the back until the front is against the board. Secure with screw 12 as shown.

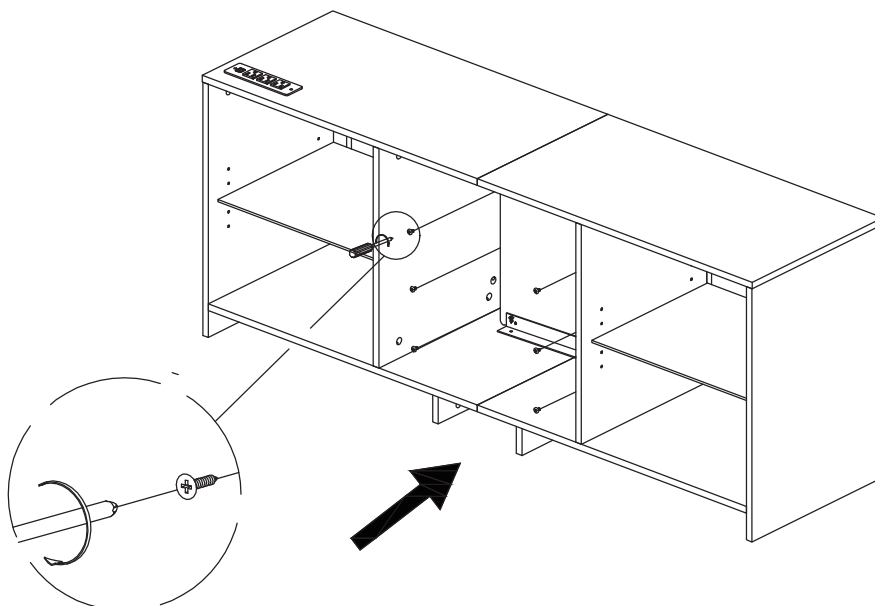

PRODUCT ASSEMBLY

STEP 22

1. Put the light strip wire through the hole (one long wire and one short wire)
2. Put the long one on the side farther from the fireplace wire, the short one on the side closer to the fireplace wire.

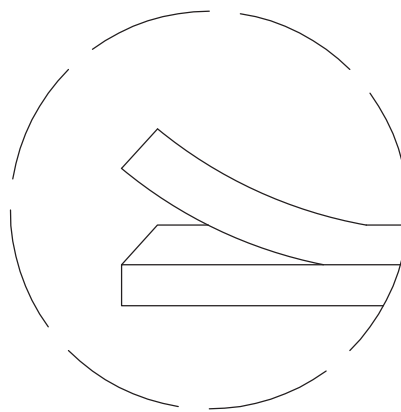
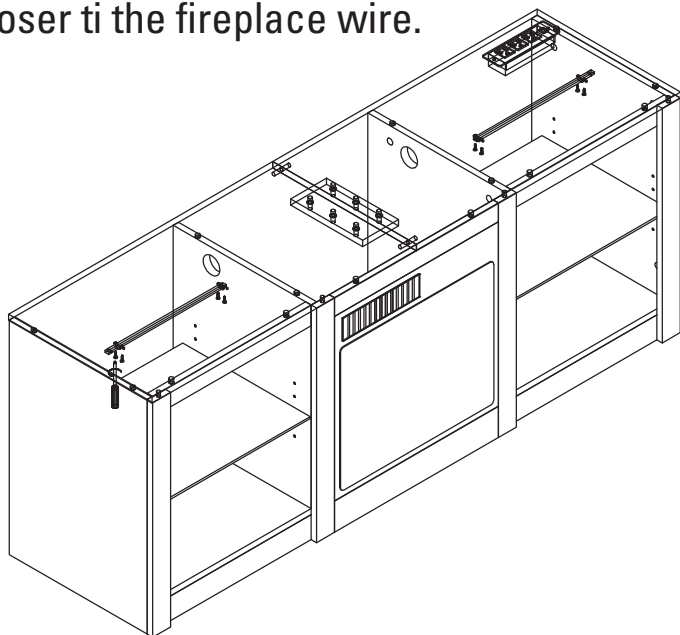

Tear off the double-sided tape of the light strip and stick it on the board.

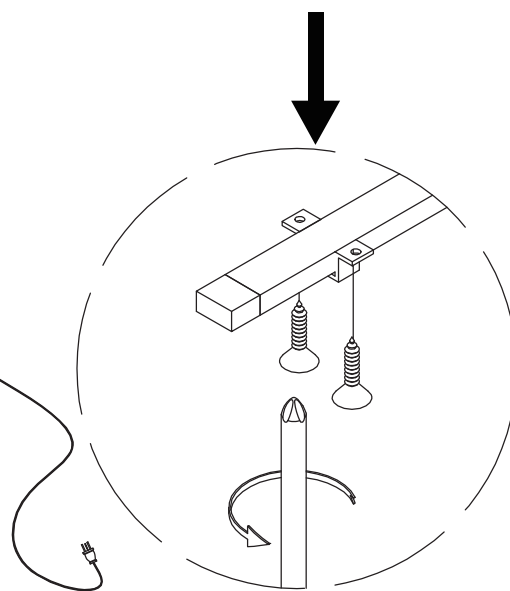
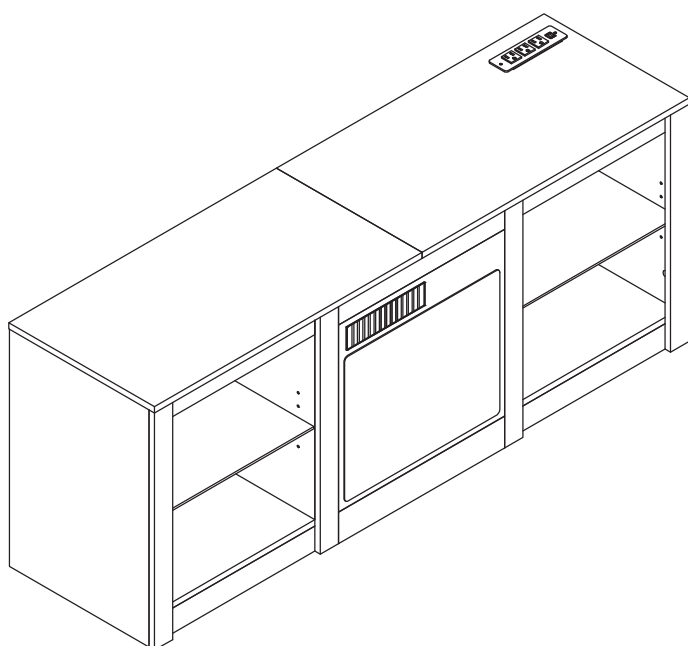

Clamp the light strip with the buckle and lock the screw

**All Finished-Congratulations! You made it!
Why not show off your hard work?**

HELP CENTER

Question about your product? We're here to help. Visit us at:

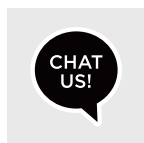

Chat Support



Product inquiry

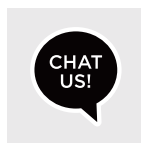

Orders FAQ

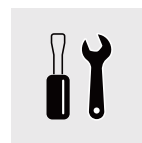

Product Assembly



Returns & Refunds

WE STAND BEHIND THE QUALITY OF OUR FURNITURE

1. If you have any issues with your item, please let us know! We will always do our best to come up with a solution that you will be happy with.
2. Please get in touch with our customer service team before returning the product.
3. And please do not throw away the original box(es) if you have not finished assembling and confirmed no quality issues.

Return Policy

1. Issue Reporting: If you encounter any issues with your item, please inform us promptly. We strive to find a satisfactory solution for you.
- 2 Contact Us First: Before returning a product, please contact our customer service team.
3. Retention of Original Packaging: Please retain the original box(es) until you have completed assembly and confirmed there are no quality issues.

Return Period: Items can be returned within 30 days of purchase.

Warranty: All purchases are covered by a one-year warranty.

Return Shipping Fees Responsibility: We stand behind the quality of our furniture and aim to resolve issues without returns whenever possible. Contact our customer service for assistance.

We cover return shipping fees if:

- 1.The item has a manufacturing defect in materials or workmanship (e.g., torn wicker, misaligned screw holes). We will provide a prepaid shipping label upon receiving photos or videos of the defect.
- 2.The item is damaged during transit (e.g., broken glass). We will provide a prepaid shipping label upon receiving photos of the damage.
- 3.You receive incorrect boxes due to a warehouse error. We will provide a prepaid shipping label upon receiving photos showing the wrong SKU numbers on the outer boxes.
- 4.Boxes are lost in transit and you no longer want the item.

Customer covers return shipping fees if:

- 1.You dislike the product upon receiving it.
- 2.You no longer need the product after receiving it.
- 3.You purchased the product by mistake and received it.
- 4.Order/shipment cancellation failed and you received the item.

Return Requirements for a Full Refund: To receive a full refund, ensure all items:
Are in brand new/unused condition (provide photos before and after packaging).
Include all accessories and parts firmly packed in the original packaging. Failure to meet these requirements may affect your refund amount.

Refund Process: Refunds are processed once the returned goods reach our warehouse.

HELP CENTER

Please feel free to **send us the text**. We will reply to you within 24 hours. Also please feel free to contact us if you have received the defective items.