

NOTICE

- * Please make sure that you have all parts indicated and they are in good condition before you begin assembly of this item. Refer to part list and hardware list below for guidance.
- * This item should be assembled on a soft surface to prevent scratching the finish during assembly.
- * This item may require periodic tightening.
- * If you are having difficulty, our friendly Customer Care team is always here to help







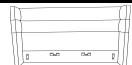

PREPARATION

- * Before beginning assembly of product, make sure all parts are present. Compare parts with part contents list and hardware contents list.
- * If any part is missing or damaged, do not attempt to assemble the product.
- * Estimated Assembly Time: 10 minutes.
- * Tools Required for Assembly (included): Wrench

CARE AND MAINTENANCE

- * Spot clean using a mild water-free solvent. Only a professional cleaner should undertake a complete overall cleaning.
- * The use of steam or water-based cleaners may cause excessive shrinking or staining.

Part List and Hardware List

PIECE	DESCRIPTION	PICTURE	QUANTITY	CARTON CALL
A	Headboard		1X	1 OF 2
B	Footboard		1X	2 OF 2
C	Sideboard		2X	2 OF 2
D	Slat		1X	2 OF 2
E	Cross Slat		2X	2 OF 2
F	Support Leg for Cross Slat		4X	2 OF 2
HW1	Phillips Screws 4*2*40MM		12X	2 OF 2
HW2	Wrench		1X	2 OF 2

COUTURE

Dimensions: 87.0"WX 86.2"DX46.3"H

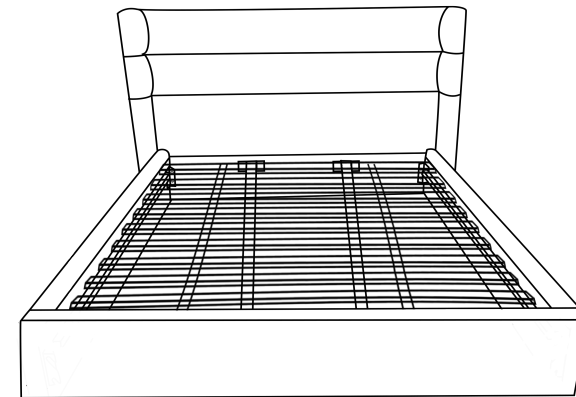

! WARNING !

Weight Capacity: 825 lbs

WARNING: DO NOT STAND ON BED

WARNING: DO NOT OVER TORQUE BOLTS/SCREWS

PREPARATION

- * Before beginning assembly of product, make sure all parts are present. Compare parts with part contents list and hardware contents list.
- * If any part is missing or damaged, do not attempt to assemble the product.
- * Estimated Assembly Time: 10 minutes.
- * Tools Required for Assembly (included): Wrench
- * If you are having difficulty, our friendly Customer Care team is always here to help.

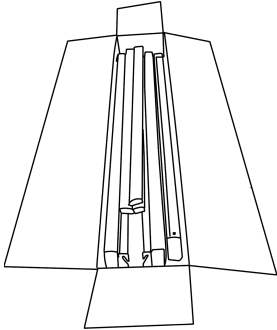
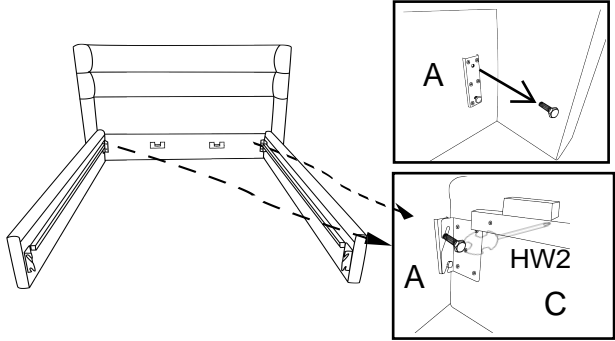
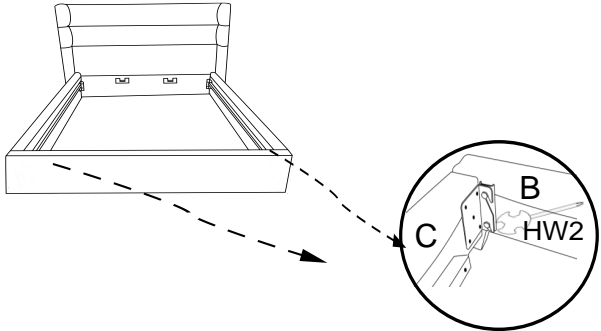
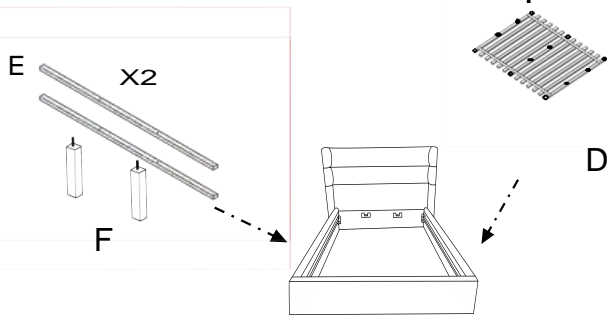
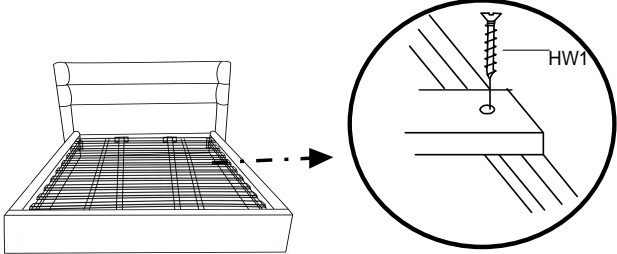
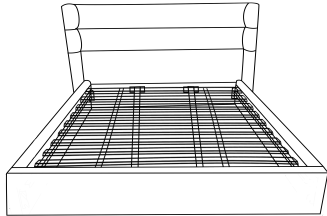
		
<p>STEP1 Open the carton box, take out the body and hardware.</p>	<p>STEP2 Please screw out one bolt from the metal card as shown, then attach the side board C and headboard A by sliding the iron plates onto the bolt, the metal card should be alignment card slot when install it, then press it lightly. Lock the bolt back on to the metal card, then tight firmly by Wrench HW2.</p>	<p>STEP3 Attach the sideboard C with footboard B by sliding the iron plates onto the bolts, the metal card should be alignment card slot when install it, then press it lightly.</p>
		
<p>STEP4 Rotate the slat legs F to the middle rod of slat E. Put it inside the middle of the bed, and then, smooth the slat D inside the bed</p>	<p>STEP5 Secure the slat with screw HW1 by using wrench HW2. There are totally 12 holes on slat to make sure it stable, it's shown in step 3.</p>	<p>It's finished as shown, your bed is ready for use.</p>