

abode

Induction Electric Hob Instruction Manual

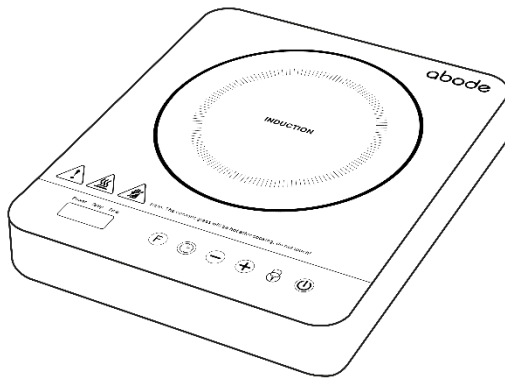

Model number(s):
AINDH1001

For Customer Services & Spare Parts please call **0345 209 7461**

IMPORTANT:
RETAIN FOR FUTURE REFERENCE

Contents

Safety Instructions	3-5
Positioning	5
Product Overview	6
Induction Introduction	7
Usage	8-16
Cleaning & Maintenance	17-18
Trouble shooting	19-20
Guarantee	21
Technical specification	22
Connections to the Mains	23

abode

Safety Instructions

Important note:

Please read this booklet before installing and switching on this appliance. The manufacturer assumes no responsibility for incorrect installation and usage as described in this booklet.

This appliance can be used by children aged from 8 years and above and persons with reduced physical, sensory or mental capabilities or lack of experience and knowledge if they have been given supervision or instruction concerning use of the appliance in a safe way and understand the hazards involved. Children shall not play with the appliance.

- Children should be supervised to ensure that they do not play with the appliance.
- If the supply lead is damaged it must be replaced by a qualified person using the correct lead, available from **0345 209 7461**.
- Packaging material is dangerous to children. Never allow children to play with packaging material.
- Check the appliance for damage after unpacking it. Do not connect the appliance if it has been damaged in transport.
- The appliance can only be used safely if it is correctly installed according to the safety instructions. The installer is responsible for ensuring that the appliance works correctly after installation.
- All operations relating to installation and regulation must be carried out by an authorised installation engineer, respecting applicable regulations, standards and the specifications of the local electricity providers.

abode

Safety Instructions

- This appliance is intended for domestic use and the household environment only. The appliance is not intended for use outside.
- Do not tamper with the appliance's interior. If necessary, call our customer helpline.
- Do not switch on the appliance if it is damaged in any way. Contact our customer helpline
- This appliance is only intended for cooking purposes, not as a heating system.
- Do not leave the appliance unattended during operation. The manufacturer is not liable for damage which is caused by improper use or incorrect operation.
- Hot oil and fat can ignite very quickly. Never leave hot fat or oil unattended. Never use water to put out burning oil or fat. Switch off the appliance. Extinguish flames carefully using a lid, fire blanket or something similar.
- Operating several cooking zones at the same time gives rise to a great deal of heat.
- The accessible parts become very hot when in operation. Never touch hot parts. Keep children at a safe distance.
- Do not use covers. These can cause accidents, due to overheating, catching fire or materials shattering, for example.
- Do not use inappropriate child safety shields or hob guards. These can cause accidents.
- The hob will become very hot. Never place combustible items on the hob. Never place objects other than cookware on the hob.
- The appliance gets hot. Do not keep combustible objects or aerosol cans in drawers directly underneath the hob.
- A defective appliance may cause electric shock. Never switch on a defective appliance. Unplug the appliance from the mains or switch off the circuit breaker in the fuse box. Contact the customer services.
- The appliance is not intended to be operated by means of an external timer or separate remote control system.
- Metal objects such as knives, forks, spoons and lids should not be placed on the surface as they can get can hot.
- After use switch off hob element by it's controls and do not rely on pan detector.

abode

Safety Instructions

- Cracks or fractures in the glass ceramic may cause electric shocks. Switch off the circuit breaker in the fuse box. Contact the customer services.
- Components inside the appliance may have sharp edges. Wear protective gloves.
- Saucepans may suddenly move due to liquid between the pan base and the hotplate. Always keep the hotplate and saucepan bases dry.
- Incorrect repairs are dangerous. Repairs may only be carried out by a qualified electrician.
- Do not use any high-pressure cleaners or steam cleaners, which can result in an electric shock.
- Never use strong and abrasive cleaning agents as they will cause surface damage.
- In the event of a malfunction, turn off the appliance's electricity supply. For repairs, call customer services.
- People with a heart pace maker should consult with their doctor before using this unit.

Positioning

- This appliance is to be placed on a counter top.

abode

Product Overview

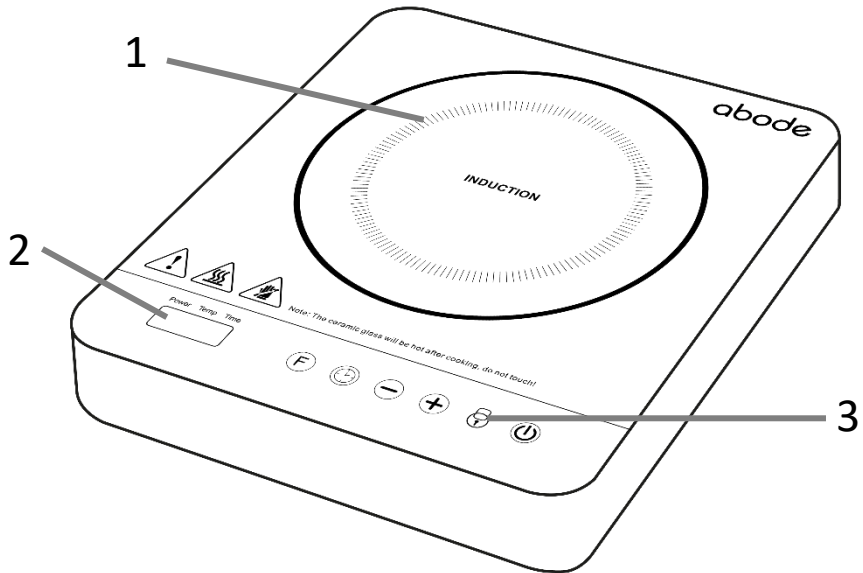

1. Cooking zone 200W – 2000W
2. Display
3. Cooking controls

Unit & Spare Parts

If any of the above parts are missing please contact the customer service team on **0345 209 7461**.

abode

Induction Introduction

Induction hobs only heat the pan rather than the cooking surface heating up like a standard electric hob. They do this by creating a magnetic field between the pan base and an element underneath the glass top; this makes induction hobs safer and cheaper to run as they use only the precise amount of energy you need.

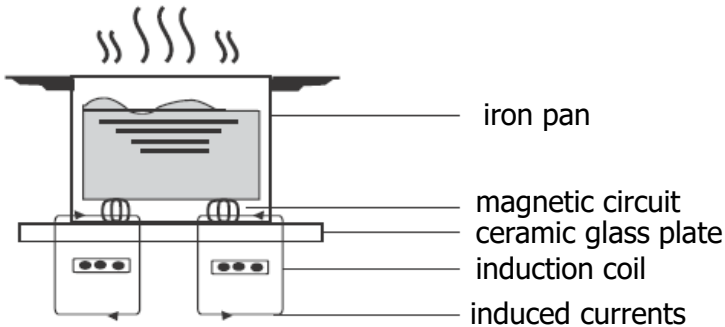

Because induction hobs create a magnetic field, pans need to either be made from a magnet metal such as cast iron or steel, or have a magnetic base. You can check whether your existing cookware is suitable by carrying out a magnet test: move a magnet towards the base of the pan. If it is attracted, the pan is suitable for induction. If you do not have a magnet then you can put some water in the pan you want to check, if 'E0' code does not flash in the display and the water is heating, the pan is suitable.

If your current cookware isn't suitable, then when purchasing new cookware and you must ensure the packaging says they are compatible with induction hobs or that they pass the magnetic test detailed above. Please note cookware made from the following materials is not suitable: pure stainless steel, aluminum or copper without a magnetic base, glass, wood, porcelain, ceramic, and earthenware.

Note:

- **Because of the powerful electromagnetic field, induction may not be suitable if you have a pacemaker fitted**
- **The glass of an induction hob only becomes hot because the pan eventually warms it up**

abode

Usage

Controls

The appliance has a single cooking zone which is controlled by the touch controls at the bottom of the hob.

Power Temp Time



The function of each touch control and the meaning of each icon is explained below:

Power Temp Time



Cooking zone display

The display shows the power, temperature, time, hot surface indicator (-H-).



Function button

Touch this button to change from power/wattage and temperature settings.



Timer button

Activate the timer function by touching this button and then set the time by using the adjustment buttons.



Adjustment buttons

The adjustment buttons can be used to adjust the power, temperature and time.



Lock function

Touch and hold for at least 3 seconds to activate and deactivate the control lock function.



Power on/off

Touch this button to turn the unit on and off.

abode

Usage

Using the touch controls

The controls respond to touch, so you don't need to apply pressure to them. Below are tips on how to use the controls:

- Use the ball of your finger, not its tip.
- You will hear a beep each time a touch is registered.
- Make sure the controls are always clean, dry, and that there is no object (e.g. a utensil or a cloth) covering them. Even a thin film of water may make the controls difficult to operate.

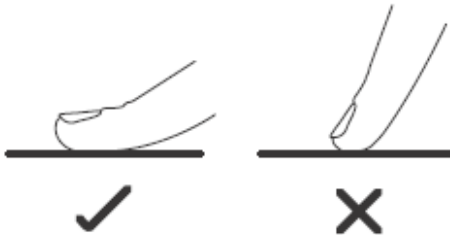

abode

Usage

Wattages & Temperatures

The settings below are guidelines only, the exact setting you will require will depend on several factors, including your cookware and the amount you are cooking. Experiment with the induction hob to find the settings that best suit you.

Heat setting	Suitability
200W - 400W / 60°C - 80°C	Delicate warming for small amounts of food
	Melting chocolate, butter, and foods that burn quickly
	Gentle simmering
	Slow warming
600W – 800W / 100°C - 120°C	Reheating
	Rapid simmering
	Cooking rice
1000W - 1200W / 140°C - 160°C	Pancakes
1400W – 1600W / 180°C - 200°C	Sautéing
	Cooking pasta
	Stir-frying (please use temperature rather than power when Stir-frying)
1800W – 2000W / 220°C - 240°C	Searing
	Bringing soup to the boil
	Boiling water

abode

Usage



To use the cooking zone

Note:

- When you touch a symbol, the respective function is activated.
- Always keep the controls dry. Moisture reduces their effectiveness.
- Do not pull pans close to the displays and sensors. The electronics could overheat.



Warnings:

- When it is first used, it is normal for the cooking zone to give off odours; this does not pose any risk and does not indicate a malfunction; they will disappear in time.
- The kitchen will become hot and humid when this appliance is used. You must therefore ensure that the kitchen is well ventilated: either keep the natural ventilation apertures open, or install a ventilation system (extractor hood).
- If using the appliance intensively for prolonged periods, you may require additional ventilation (e.g. by opening a window) or more effective ventilation (e.g. by increasing the hob's ventilation, if possible).

1. Plug in the appliance and turn on the power at the socket, '-L-' will be shown on the display.
2. Turn on the unit by touching the  button, the appliance will beep and the display will show '0' and there will be a red indicator light above the word Power near the display. If after a short period of time no other button is touched the '-L-' will be shown on the display and the internal cooling fan will operate. Simply touch the power button again or turn the unit off at the plug.
3. Place a suitable pan on the zone. Make sure the bottom of the pan and the hob surface are clean and dry.
4. Set the power (wattage) or temperature (°C) that you require for the cooking zone by first touching the  button. If Wattage is selected then 1000 will be shown on the display and an indicator light will light up above the word Power. If Temperature is selected then 120 will be shown on the display and an indicator light will light up above the word Temp.

abode

Usage

5. You can modify the power or temperature setting of the cooking zone at any time during cooking. To do this touch the   buttons. The power range and temperature ranges are shown in the below table:

Temperature	Power
60	200
80	400
100	600
120	800
140	1000
160	1200
180	1400
200	1600
220	1800
240	2000

6. To switch the cooking zone off, simple touch the power button. The unit will turn off however the internal cooling fan will continue to run for a period of time and the '-H-' symbol will be shown on the display to show that there is residual heat on that cooking zone. The '-H-' symbol will stay lit until the cooking zone has cooled down sufficiently. It can also be used as an energy saving function if you want to heat an additional pan or keep the contents of a pan warm, use the zone that is still hot.



Important note: The glass will be hot after cooking, do not touch!

abode

Usage

Locking the controls

You can lock the controls to prevent unintended use (for example children accidentally turning the cooking zones on).

To lock the controls touch the child lock  control for 3 or more seconds, an indicator light will light up above the  control.

Note: When the controls are locked, all the controls except the Power on/off control are disabled. If the hob is turned off when the controls have been locked you will have to unlock the controls when the hob is powered on.



To unlock the controls touch and hold the  control for at least 3 seconds. All controls can now be unlocked and can be used.

Using the Timer

You can use the timer to turn the cooking zone off after the set time is up.

Note: You can set the timer for up to 180 minutes.

Make sure the hob is turned on and that a suitable pan has been placed on the zone you wish to use. Make sure the bottom of the pan and the hob surface are clean and dry.

1. Turn on the units and set the cooking zone to the power or temperature you require. As set out in the previous 2 pages.
2. Touch the timer control  and the display will turn to '0' and an indicator light will light up above the word Time.
3. Set the time by touching the   controls. By touching these controls the timer will increase by 10 minutes or decrease by 1 minute.

abode

Usage

5. When the time is set, it will begin to count down immediately. The display will show the remaining time and flick between this and the power/temperature every 10 or so seconds.
6. When cooking timer expires, the cooking zone will switch off automatically. Please note if you want to change the time after the timer is set, you have to cancel the timer function and start from step 1.

abode

Usage

Residual heat warning

When the hob has been operated there will be some residual heat. The display of controls of which ever cooking zone has been used will show a '-H-' symbol to warn you of the residual heat and to keep away from it.

The '-H-' symbol will stay lit until the cooking zone has cooled down sufficiently.

Over heat protection

The hob is fitted with a temperature sensor which can monitor the temperature inside the induction hob. If an excessive temperature is detected then the hob will stop operation automatically and switch itself off.

Auto shutdown

Another safety feature of the hob is an auto shutdown, this occurs if you ever forget to switch off a cooking zone and certain time has passed.

Detection of Small Articles

When an unsuitable size or non-magnetic pan (e.g. aluminum) or some other small items (e.g. knife, fork, key) have been put on the hob. The hob will automatically go in to standby after a period of 1 minute.

Please note that the fan will keep working and will cool the induction hob for a further minute after the hob has gone in to standby mode.









abode

Usage

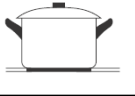
Pans & energy saving

The following advice is to prevent damage to pans and help you save energy:

Zones	Suitable pan sizes (diameter)
2000W (max)	200mm

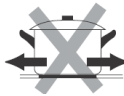
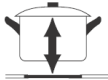
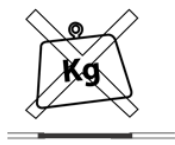
X		✓
Do not use small pans on large zones	 	Always use pans that are the right size for each zone
Do not cook without a lid or with the lid half off, as this wastes energy	 	Place a lid on pans
Do not use damaged pans, which do not sit evenly on the hob: pans may tip over.	  	Only use pans with a thick, flat bottom
Do not use large pans on zones near the controls, as they may be damaged by the high temperatures	 	Always place pans centrally over the burners not to one side
Do not slide, or they may scratch the glass	 	Always lift pans off the hob
Do not use excessive weight or strike the hob with heavy objects		Be careful when handling pans when they are on the hob or have just been taken away from the burner

abode

Cleaning and Maintenance:

Important notes:

- The appliance will become hot during operation, allow the appliance to cool down before cleaning.
- Do not use any high-pressure cleaners or steam cleaners.
- Wash new sponge cloths thoroughly before use.
- Follow all instructions and warnings included with the cleaning agents.

How to clean

Observe the information in the table below to ensure that the surface is not damaged by using the wrong type of cleaning agent. Do not use:

- Harsh or abrasive cleaning agents,
- Cleaning agents with a high concentration of alcohol,
- Hard scouring pads or sponges,
- High-pressure cleaners or steam cleaners.

Surface type	How to clean
Glass	Glass cleaner: Clean with a soft cloth. Do not use a glass scraper.

abode

Cleaning and Maintenance:

How to clean:

- After each use, clean the surface of each zone once they have cooled down. If any residue is left (baked-on food, drops of grease etc.), however little, it will become stuck to the surface and more difficult to remove later.
- Always clean off any liquid as soon as it is spilt: you will save yourself any unnecessary effort.
- Do not leave acidic liquids (e.g. lemon juice, vinegar, etc.) on the hob.
- Where possible, do not allow salt to come into contact with the surface of the electric hob.

Causes of damage:

- Rough pot and pan bases scratch the ceramic.
- Avoid boiling pots dry. This may cause damage.
- Sugar can cause the surface to blister if not removed immediately
- Never place hot pots or pans on the control panel, the display area or the surround. This may cause damage.
- Damage can occur if hard or pointed objects fall on the hob.
- Aluminium foil and plastic containers melt on hot hotplates.
- Oven protective foil is not suitable for your hob.
- Unsuitable cleaning agents can cause discolouration and/or stains.
- Spillages can cause discolouration if not removed/cleaned immediately.
- Dragging or scraping pans across the hob can cause discolouration, pans should be lifted when moving them.

abode

Trouble Shooting:

Problem	Solution
No power	<p>The plug is not plugged in</p> <p>Connect the appliance to the electricity supply</p>
	<p>Power cut or faulty fuse</p> <p>Check whether other kitchen appliances are working or check in the fuse box to make sure that the fuse for the appliance is working</p>
Controls aren't working	<p>The child lock/control lock is operational</p> <p>Unlock the child lock/control lock</p>
No heating	<p>Incorrect cookware is being used</p> <p>Induction hobs create a magnetic field so pans need to either be made from a magnet metal such as cast iron or steel, or have a magnetic base. If your current cookware isn't then new induction suitable cookware will have to be purchased.</p>
The indicator is showing EO	<p>Incorrect cookware is being used</p> <p>Induction hobs create a magnetic field so pans need to either be made from a magnet metal such as cast iron or steel, or have a magnetic base. If your current cookware isn't then new induction suitable cookware will have to be purchased. If no suitable pan has been put on the hob then the display will show 'EO'</p>
	<p>No pan has been put on a cooking zone</p> <p>Put a suitable pan on to the required cooking zone</p>

abode

Trouble Shooting:

Problem	Solution
Scratches, discolouration or blistering	Sliding or dragging pans may scratch the glass
	Always lift pans off the hob
	Rough pot and pan bases scratch the ceramic
	Replace cookware
	Spillages can cause discolouration
	Remove/clean all spillages immediately
	Sugar can cause the surface to blister
Remove/clean all spillages immediately	
Cookware is damaged	Cookware can become deformed if boiled dry
	Never boil pans dry

Error Codes:

Code	Problem	Solution
E0	Use of incorrect type of pan or a pan that is too small	Use the correct type and size of pan
E2	PCB error	Please contact customer services
E3 / E4	Voltage too high / low	Connect to the appliance to the correct rated power outlet
E5 & E6	Over heated	Turn the unit off and allow it to cool down completely before turning it on again and using it

abode

Guarantee

This product is guaranteed for 12 months from the date of the original purchase. If any defect arises due to faulty materials or workmanship you must contact customer services with the original proof of purchase so a replacement or refund can be arranged.

Refund or replacement is at the discretion of Customer Services.

The following conditions apply:

- Customer Services will require a valid proof of purchase at the point of replacement or refund.
- The product must be installed and used in accordance with the instructions contained in this instruction guide and any other instructions for use which has been supplied.
- It must be used for domestic purposes only and for its intended use.
- This guarantee does not cover wear and tear, damage, misuse or consumable parts.

This does not affect your statutory rights.

For Customer Services & Spare Parts please call **0345 209 7461**

abode

Technical Specification

Model number	AINDH1001
Rated Voltage	220V – 240V ~ 50Hz/60Hz
Wattage	2000W
External Dimensions (H x W x D) (CMS)	6.5cm x 27cm x 31cm

abode

Connections to the mains

This appliance is designed to operate from a mains supply of 220-240V~50/60Hz.

Check that the voltage marked on the product corresponds with your supply voltage.

How to change the fuse

1. Slot the end of a screwdriver into the recess in the fuse holder of the plug.
2. Pull the fuse holder upwards until free of the plug and slide the fuse out.
3. Replace the fuse and replace fuse holder, pushing down until locked into place.

Important: Only ever use a 13 amp fuse.

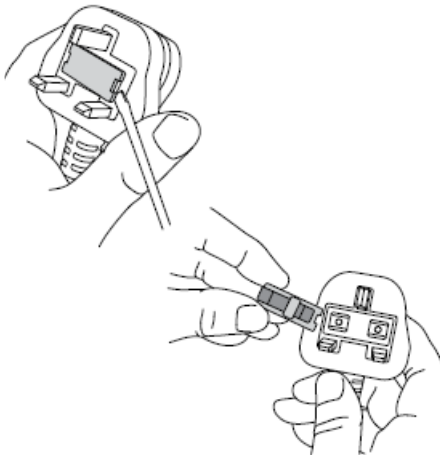

abode

abode

Imported by: Product Care Trading Limited, Wigan, WN2 4AY/ PCT (NI) Ltd,
Belfast, BT5 5AD.

For Customer Services & Spare Parts please call **0345 209 7461**

UK
CA

C E

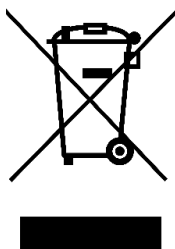

The 'wheelee bin' symbol is known as the 'Crossed-out wheelee bin Symbol'.

When this symbol is marked on a product/batteries, it means that the product/batteries should not be disposed of with your general household waste. Only discard electrical/electronic/battery items in separate collection schemes, which cater for the recovery and recycling of materials contained within. Your co-operation is vital to ensure the success of these schemes and for the protection of the environment. For your nearest disposal facility, visit www.recycle-more.co.uk or ask in store for details.

SEDEX – Connecting businesses and their global suppliers to share ethical data and enabling improvement in ethical performance. Visit www.sedex.org.uk for further information.

We reserve the right, due to possible changes to design, to alter the instruction manual without prior notice.

Revision 1.1