

INSTALLATION INSTRUCTIONS

Easy To Install

What's Needed



Phillips screwdriver

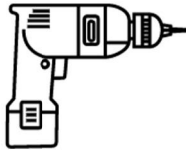

Power drill



5/16 in. drill bit



Level

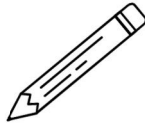

Pencil

What's Included

One (1) shelf

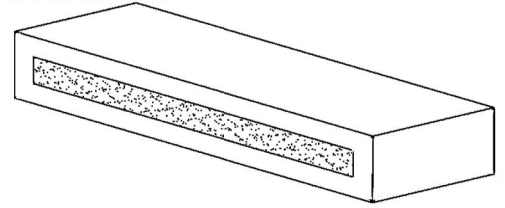

One (1) mounting bracket

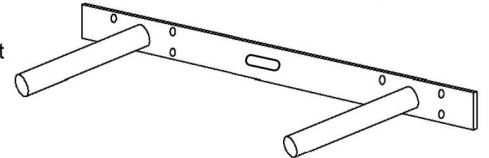

Ten (10) screws



Ten (10) dry wall anchors

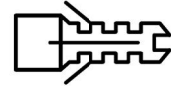

Installation

1 PREPARING FOR INSTALLATION

Place backplate against wall in the desired position. Use a level on top of the bracket to insure bracket is level. Then mark each hole to be used to install bracket.

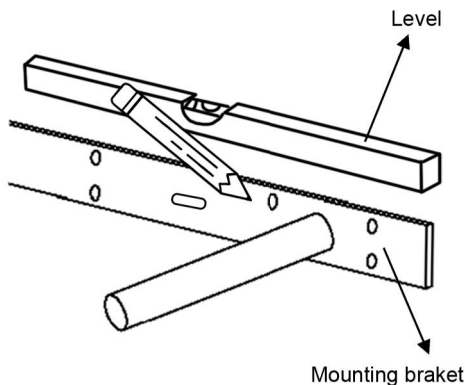

2 INSTALLING THE BACKPLATE

Using a power drill, drill a hole on the wall at the pencil mark, insert the anchor into the hole, tap the anchor flush with the wall. After all the anchors are secured in place, position bracket to be mounted to the wall. Using a power drill with Phillips tip or Phillips screwdriver, place screws provided into each anchor and tighten until they are firm to the face of the bracket.

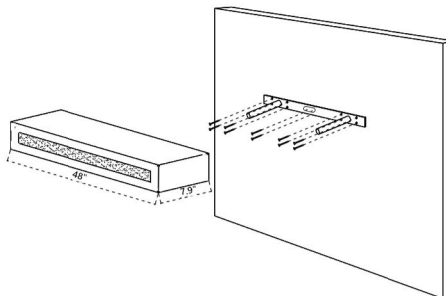

3 SLIDE THE SHELF ONTO BRACKET

