

ASSEMBLY INSTRUCTIONS

01/22

v1



Warning – CHOKING HAZARD – Small Parts Not for children under 3 years. Adult assembly required.

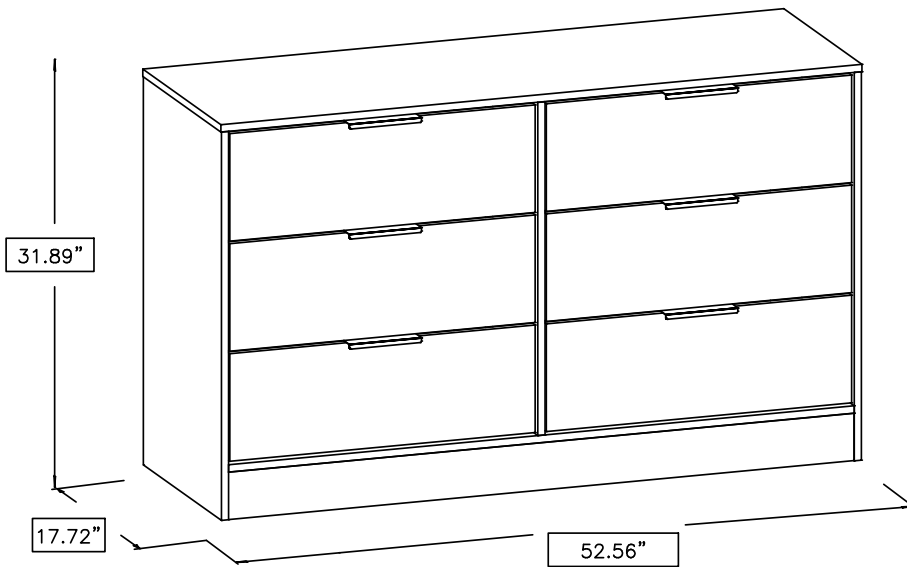
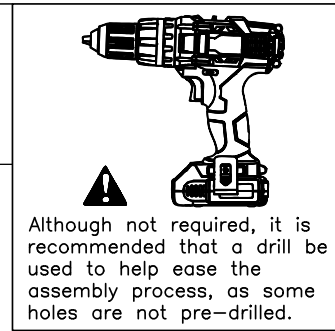
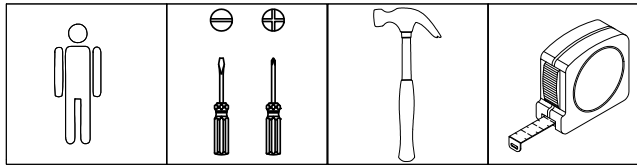

Part Identification

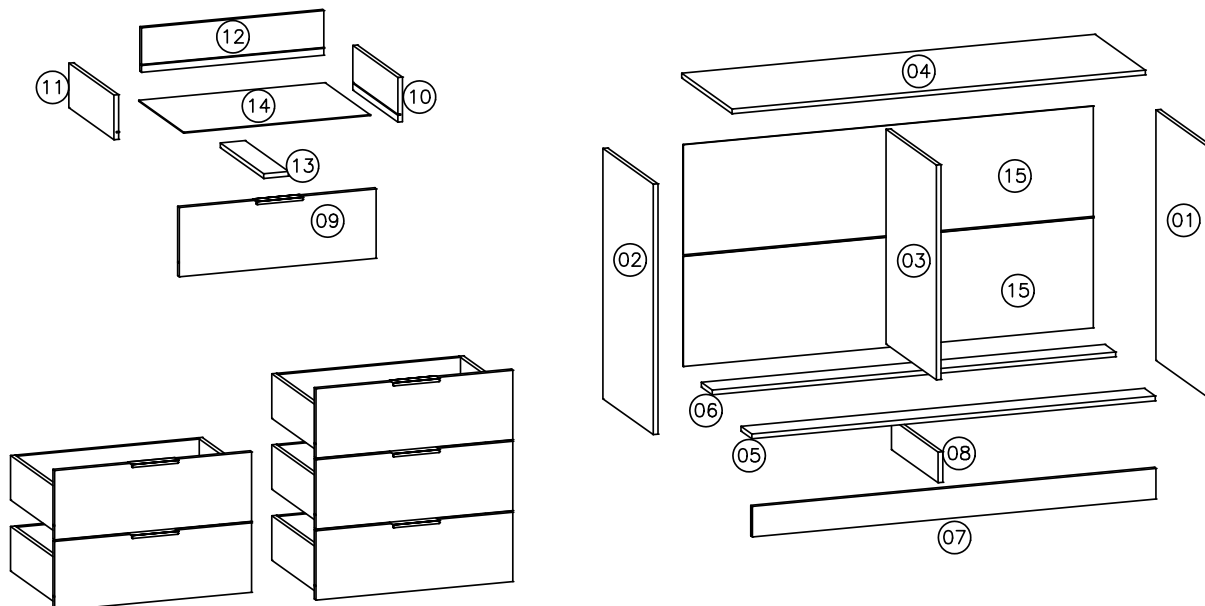



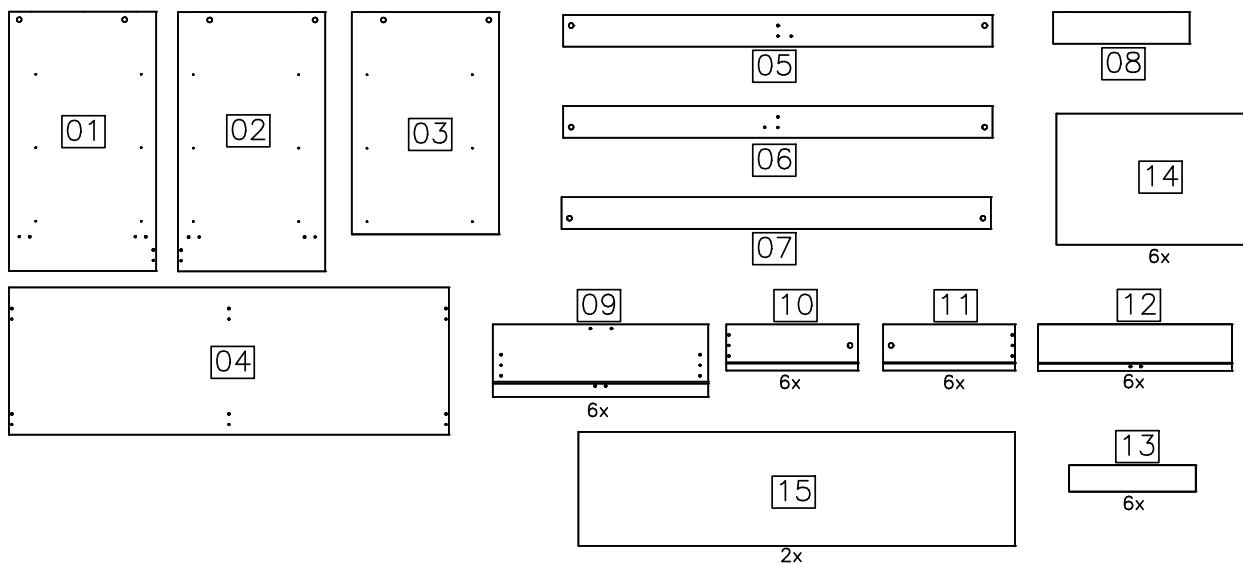

List of pieces



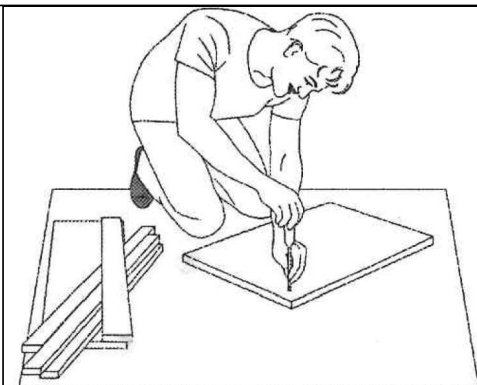

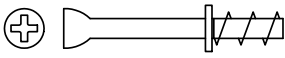
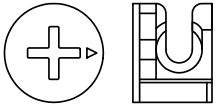
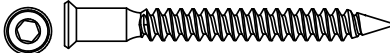

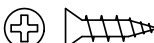
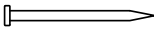
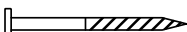
Code	Description	Descrição (Internal production data)	Amount	Length (in.)	Width (in.)	Thickness (in.)	Box
01	Right side panel	Lateral direita	1	30.98"	17.60"	.59"	A
02	Left side panel	Lateral esquerda	1	30.98"	17.60"	.59"	A
03	Divider	Divisória	1	26.57"	17.60"	.59"	A
04	Top	Tampo	1	52.56"	17.60"	.59"	A
05	Bottom/Base front	Base frontal	1	51.30"	3.78"	.59"	A
06	Bottom/Base Rear	Base traseira	1	51.30"	3.78"	.59"	A
07	Front skirting	Rodapé frontal	1	51.30"	3.78"	.59"	A
08	Internal skirting	Rodapé interno	1	16.30"	3.78"	.59"	A
09	Drawer front	Frente de gaveta	6	25.04"	8.58"	.59"	A
10	Right Side of Drawer	Lateral de gaveta direita	6	15.75"	5.51"	.59"	A
11	Left Side of Drawer	Lateral de gaveta esquerda	6	15.75"	5.51"	.59"	A
12	Back of Drawer	Cabeceira de gaveta	6	23.19"	5.51"	.59"	A
13	Drawer Support	Sarrafo de gaveta	6	15.12"	3.15"	.59"	A
14	Base of Drawer	Fundo de gaveta	6	23.70"	15.67"	.12"	A
15	Back Panel	Costa	2	52.17"	13.62"	.12"	A

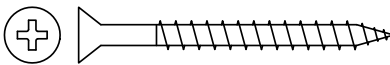
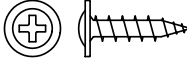
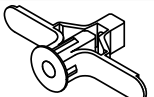

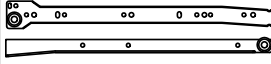
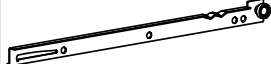
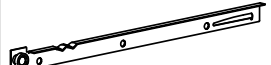
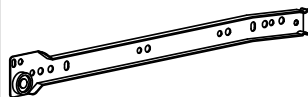
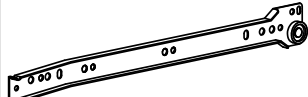
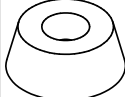
We Recommend you use the Box that your furniture came in as the base for your work space. This can help prevent and unnecessary damages from occurring.

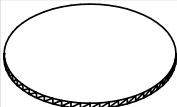

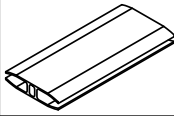
Hardware			
	Code	Description	Amou.
PM	30945	 Cam Screws	24
TM	30950	 Cam Locks	24
PE18	75515	 Screw 5x40	16
C1	1802	 Dowel 6x30mm	88
PC3	4214	 Screw 3,5x14	64
PR1	107	 Nail 10x10	40
PR2	108	 Nail 12x12	6
Anti-tipping installation			
<p>Warning: For Measures of Safety, it is recommended that this item be fixed to the wall, to avoid overturning, if this happens it can cause serious or fatal injuries.</p> <p>ATENCION: Por medidas de seguridad se recomienda fijar el mueble a la pared para evitar Volcamiento del mismo, si esto llegase a ocurrir puede causar lesiones graves o fatales.</p>			
SF	55606	 Mounting bracket	2
ANY	55607	 Clamp	1
PC10	51980	 Screw 4,5x50	2
PF4	1178	 Screw 3,5x16 BC	2
BG	32069	 Adapter sleeve	2

CM4			400mm metal slide set	6
CM4A			Right Drawer slide	
CM4B			Left drawer slide	
CM4C	5288		Metallic slide for left sided panel	
CM4D			Metallic slide for right sided panel	
SD	1901		Shoe black	6
PX	BR=63053 AZP=81136 CZS=81136		Handle	6
TP1	BR=45292 AZP=81298 CZS=81300		Screw cap cover 19mm	12
CZ3	58788		Allen key	1
PH	BR/AZP/CZS=81616		Finishing profile	2
CG	899		Angle bracket	1

Helpful Tips

INSTALLING CAM

Identify arrow on head of cam. Arrow MUST point toward hole in edge of panel. Push cam all the way down into hole.

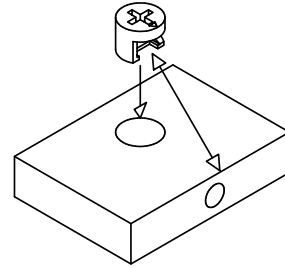

CAM AND DOWEL ALIGNMENT

Ensure the arrow on the cam points toward hole and insert cam dowel into hole. Make sure pieces join together.

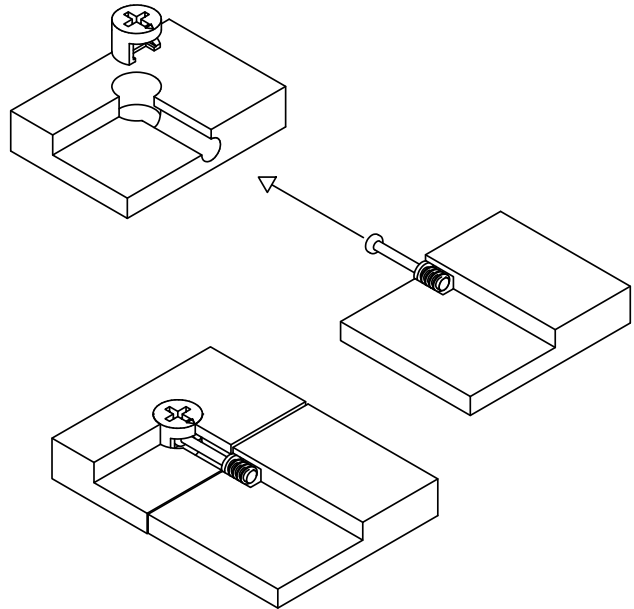

TIGHTENING CAM

Use screwdriver to turn cam. Turn cam (clockwise) until fully tightened. Slightly more than half a turn.

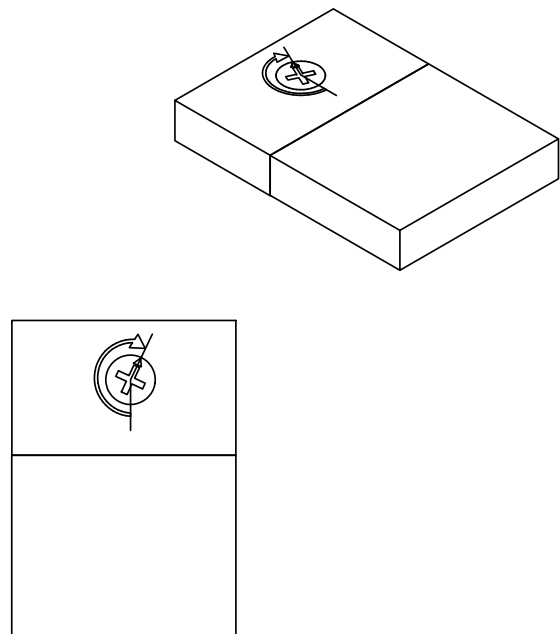

1A

Drawer Preassembly

This process is repeated six times (x6)

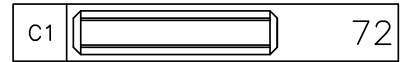
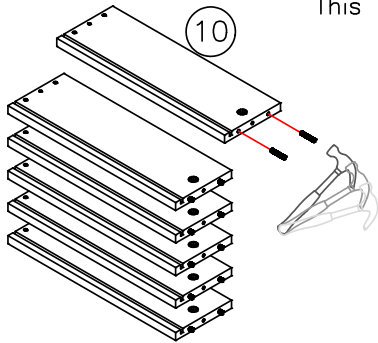

1B

This process is repeated six times (x6)

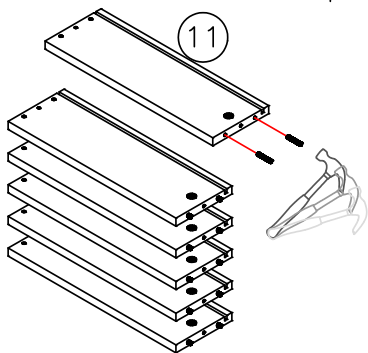

1C

This process is repeated six times (x6)

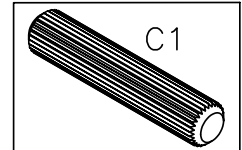
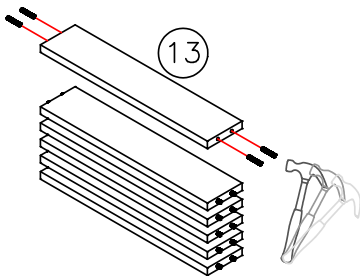

1D

This process is repeated six times (x6)

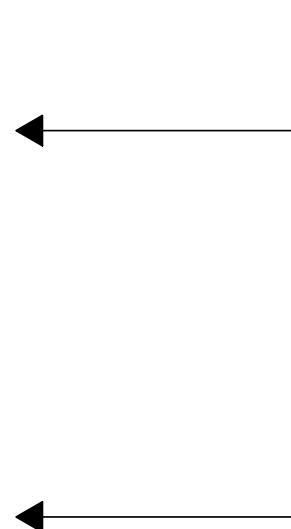
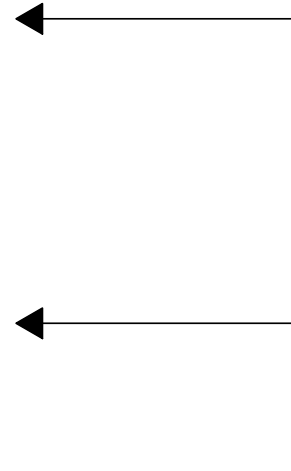
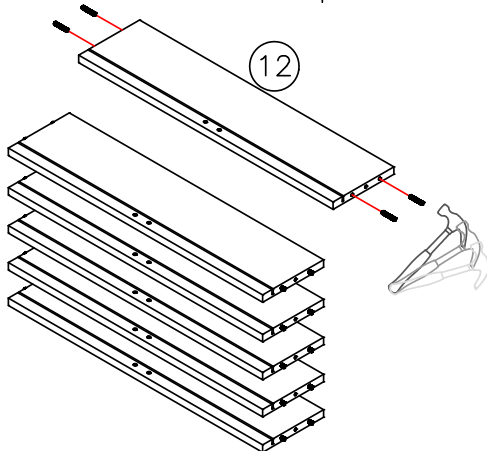

1E

Drawer Preassembly

This process is repeated six times (x6)

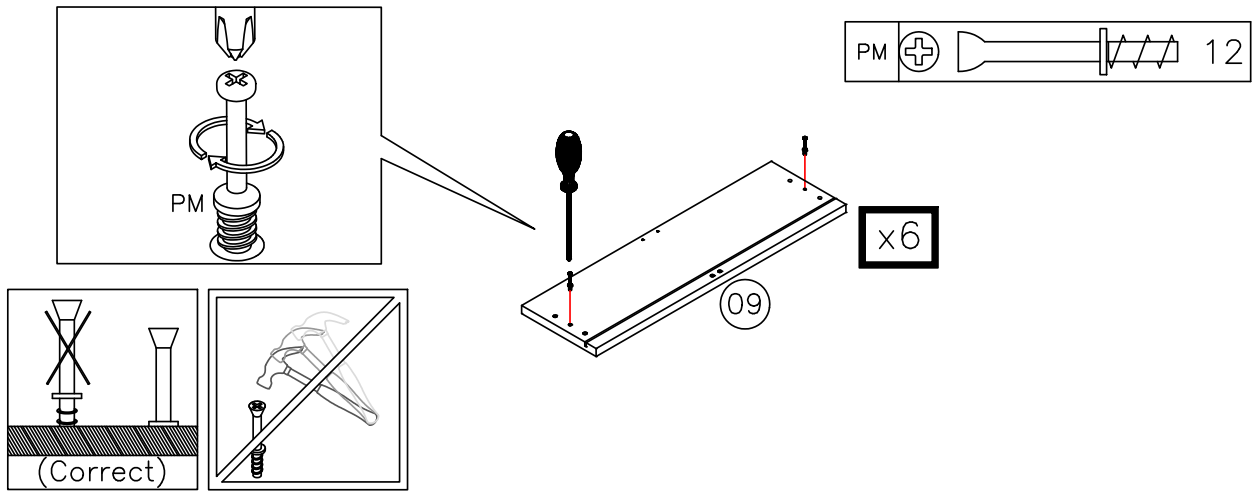

02

Drawers Mounting

This process is repeated six times (x6)

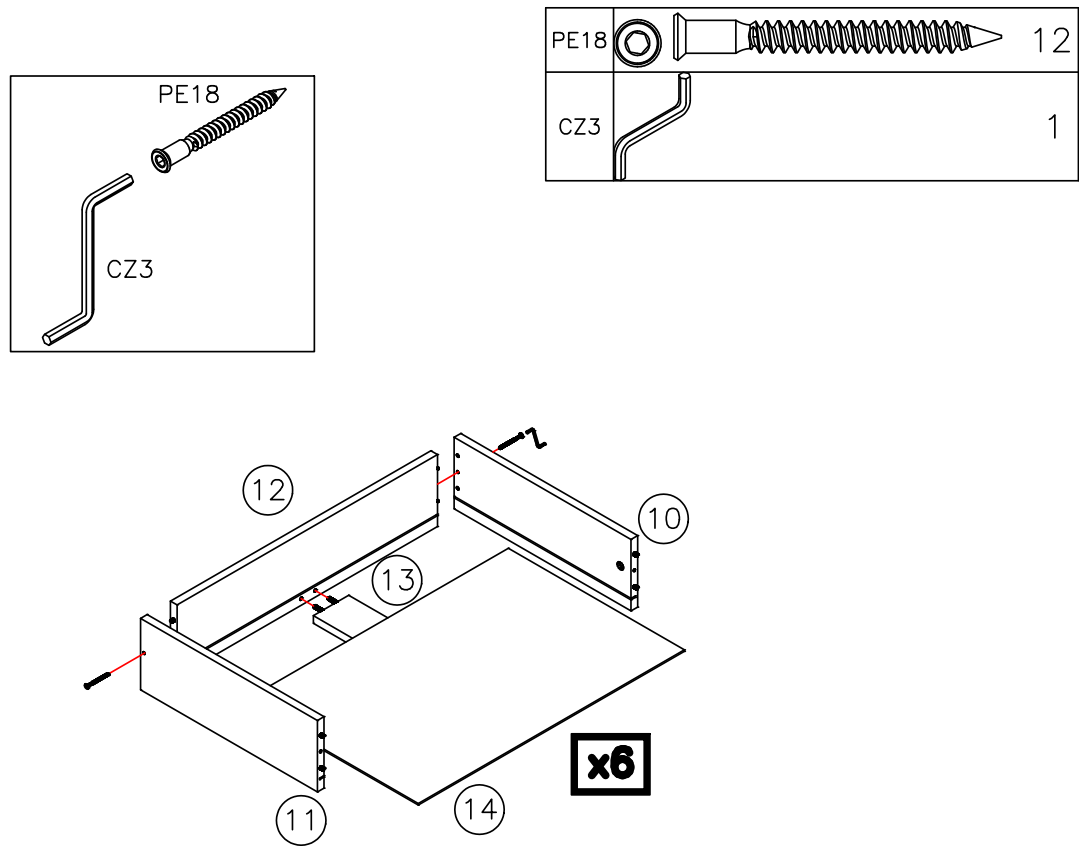

03

Drawers Mounting

This process is repeated six times (x6)

TM			12
TP1			12

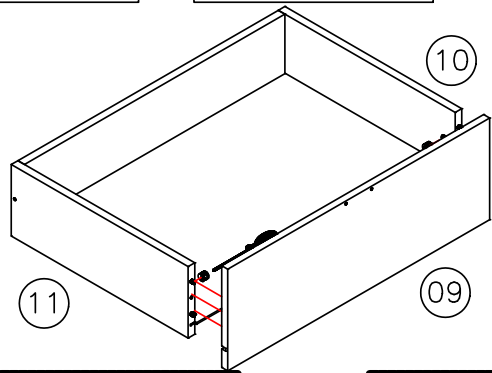
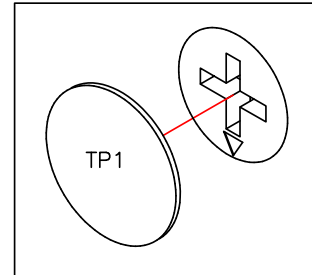
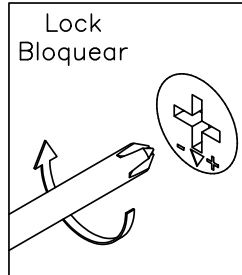
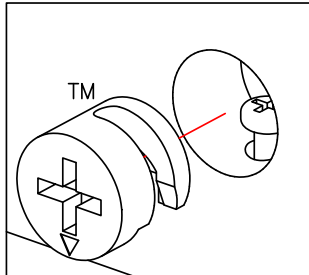

x6

04

CM4A		6
CM4B		6
PC3		22

This QR code will take you to a YouTube video that will demonstrate how to properly install the Glide rail. You can also search YouTube for *K1 GLIDE RAIL.

! Please ensure that these screws are complete screwed in. As failure to do so could cause issues when installing the drawer.

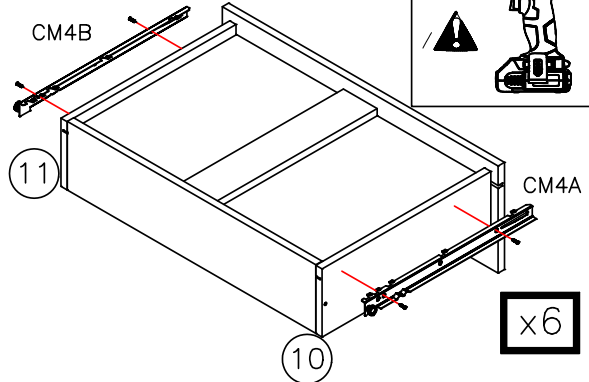
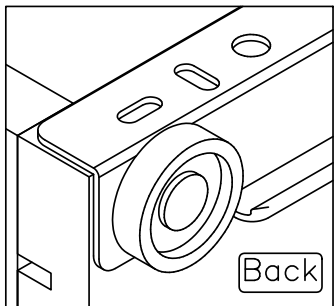
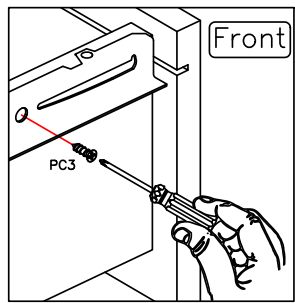
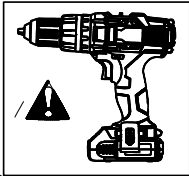

! Wheels should Always be towards the back of the Drawers



x6

05

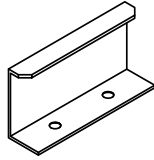
Drawer final assembly

PX		6
PC3		12

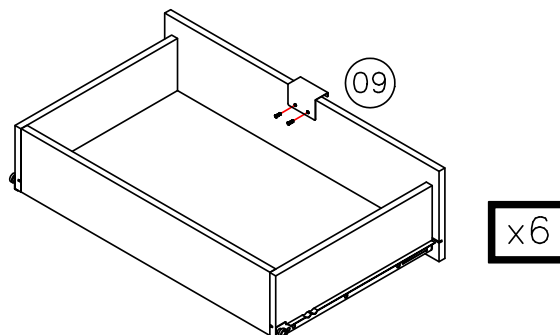
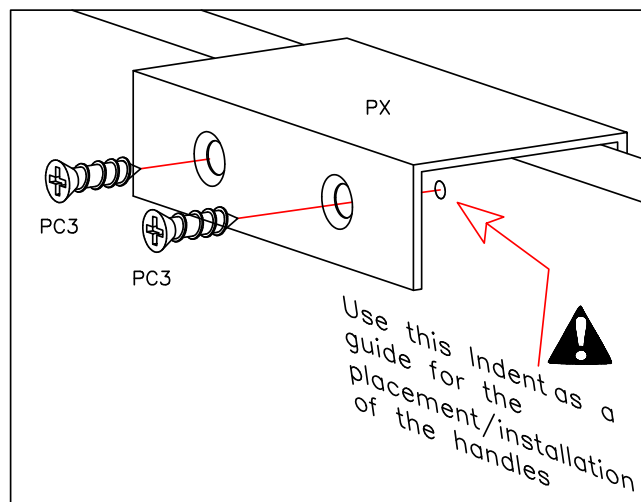

06

Preassembly of parts

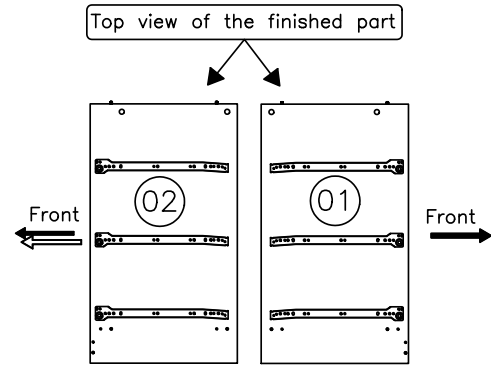

C1		4
PM		6
PC3		12
CM4C		3
CM4D		3

Detailed view of CORRECT hole location in the rail for the "PC3" Screw

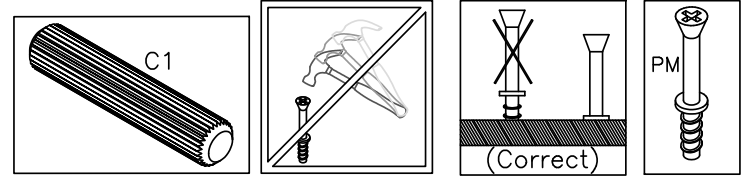
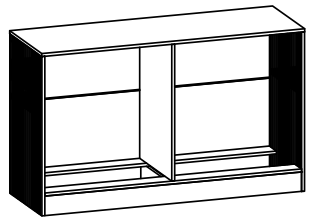
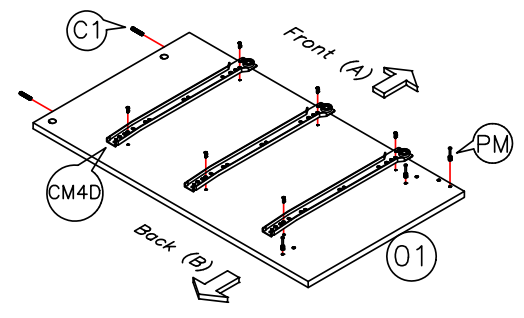
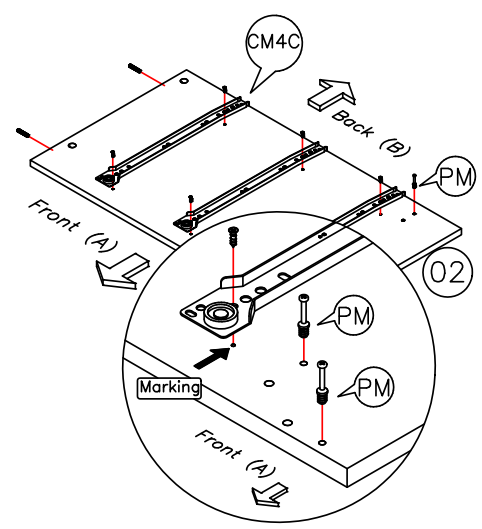
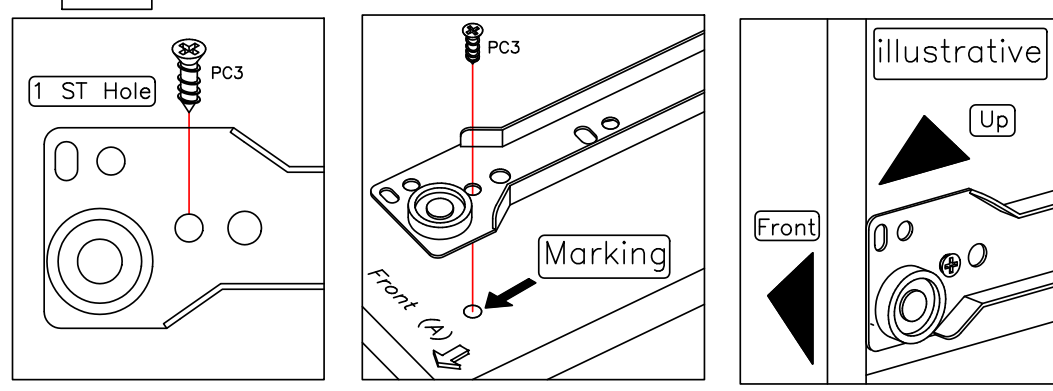

07

Preassembly of parts

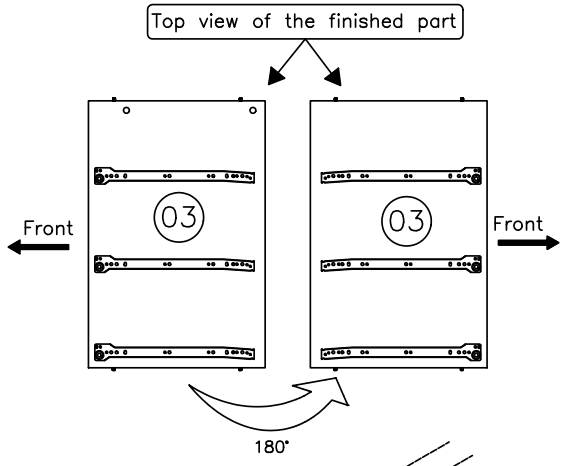

C1		4
PC3		12
CM4C		3
CM4D		3

Detailed view of CORRECT hole location in the rail for the "PC3" Screw

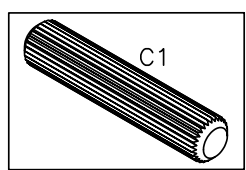
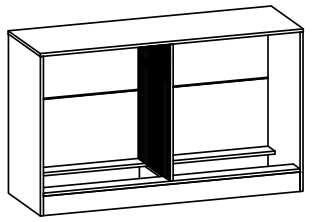
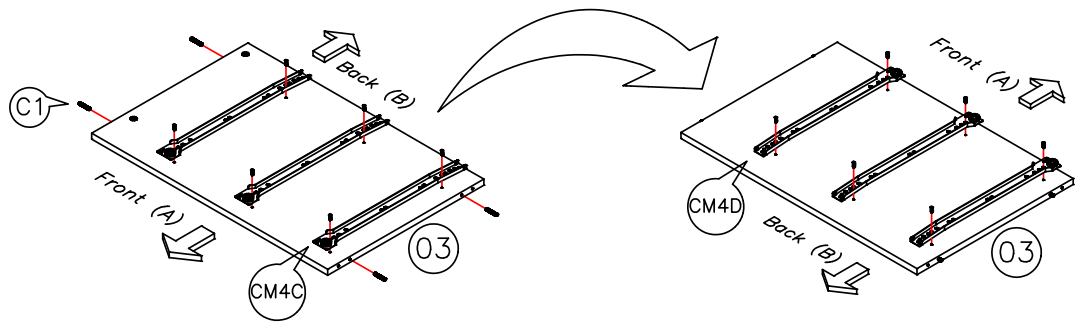
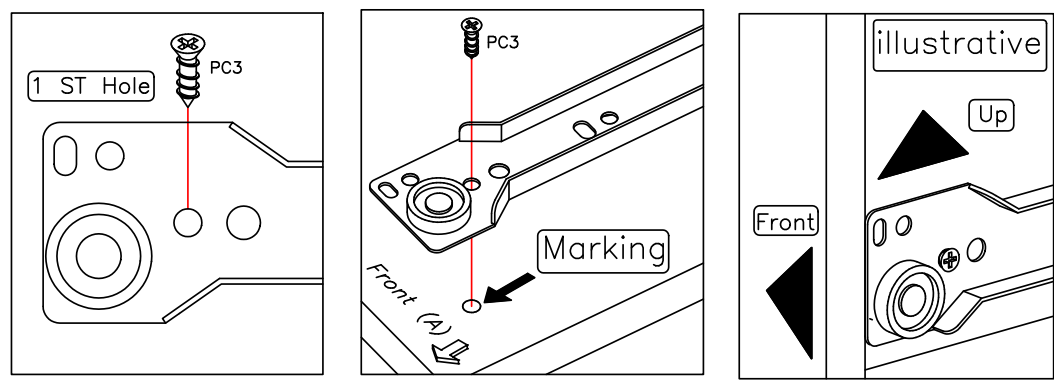

08

Preassembly of parts

C1		8
----	---	---

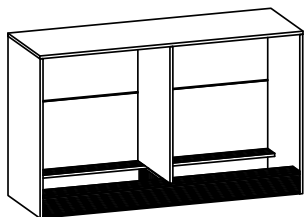
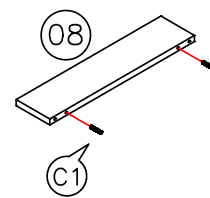
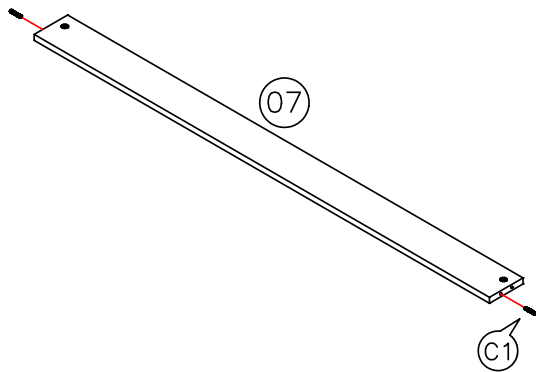
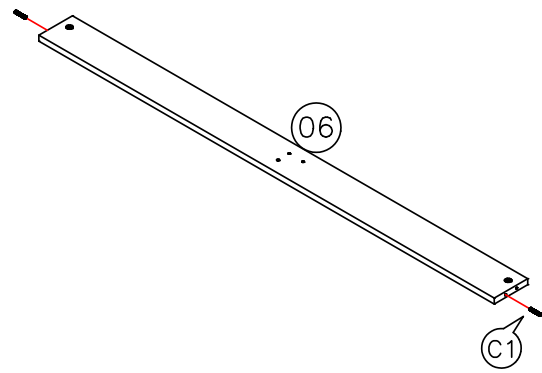
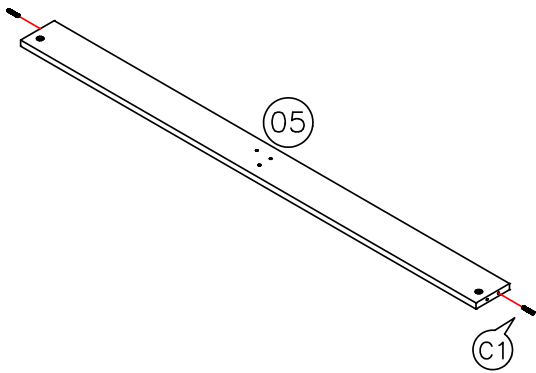
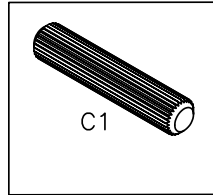

09

Preassembly of parts

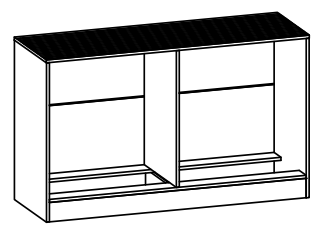
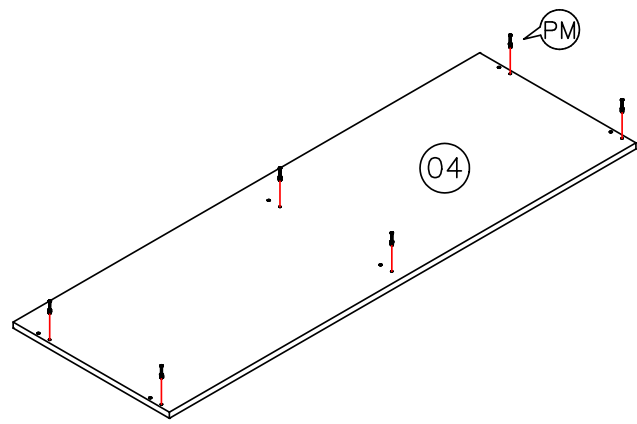
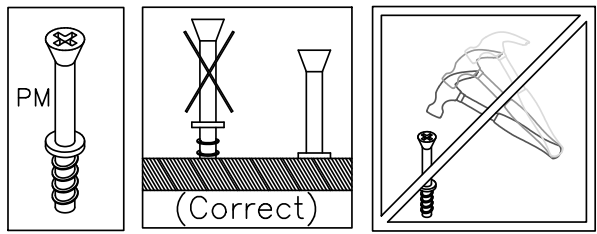
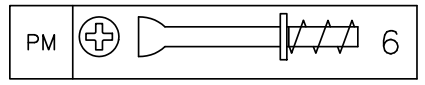

10

Product Assembly

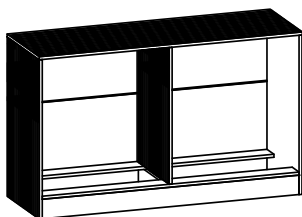
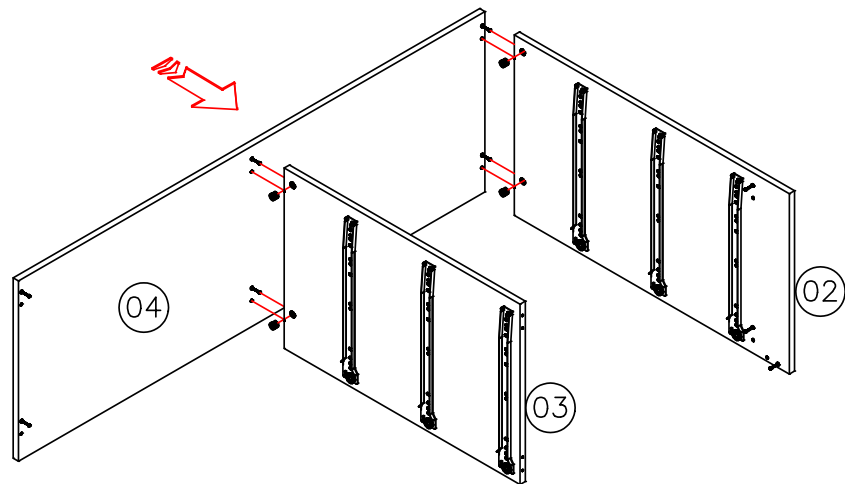
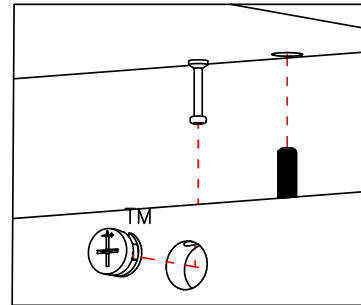
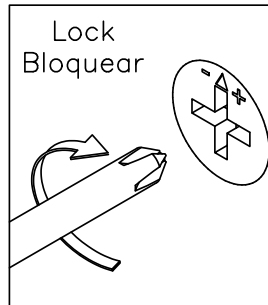
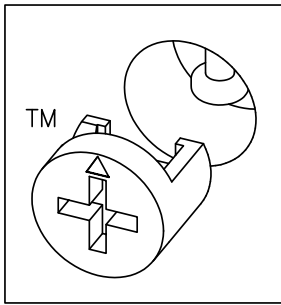
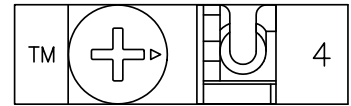

11

Product Assembly

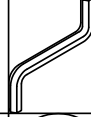
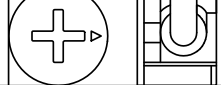
PE18		2
CZ3		1
TM		3

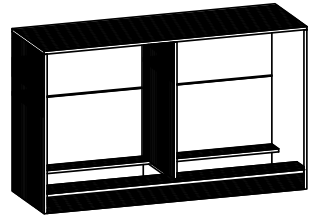
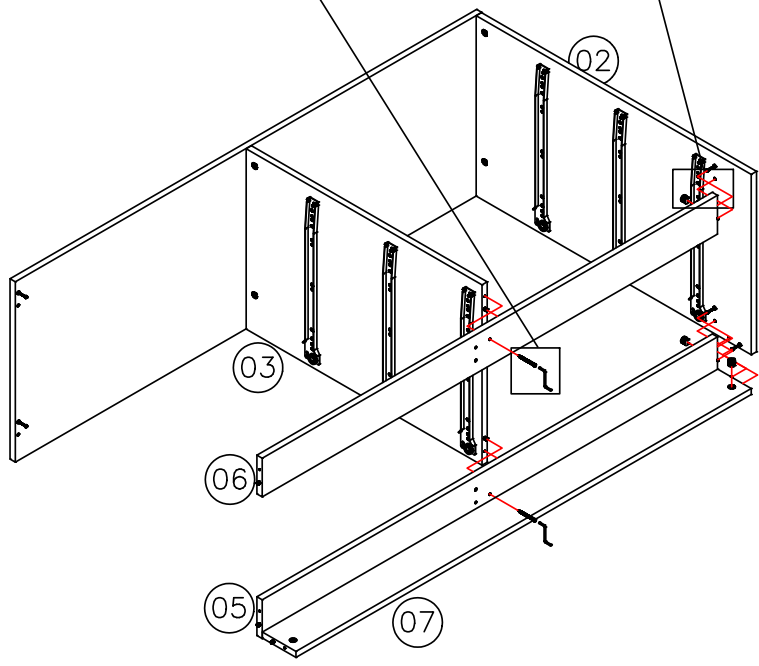
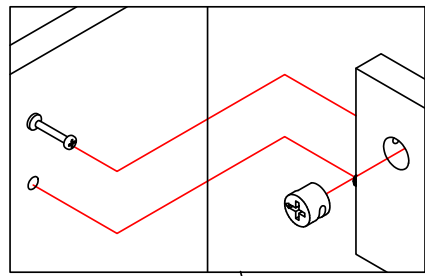
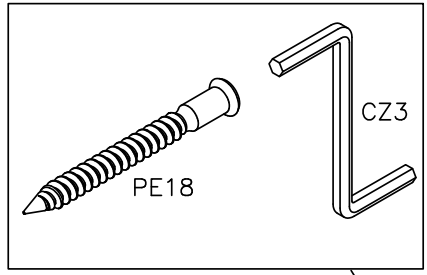

12

Product Assembly

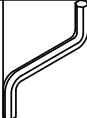
PE18		2
CZ3		1

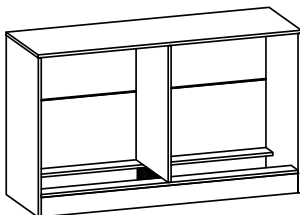
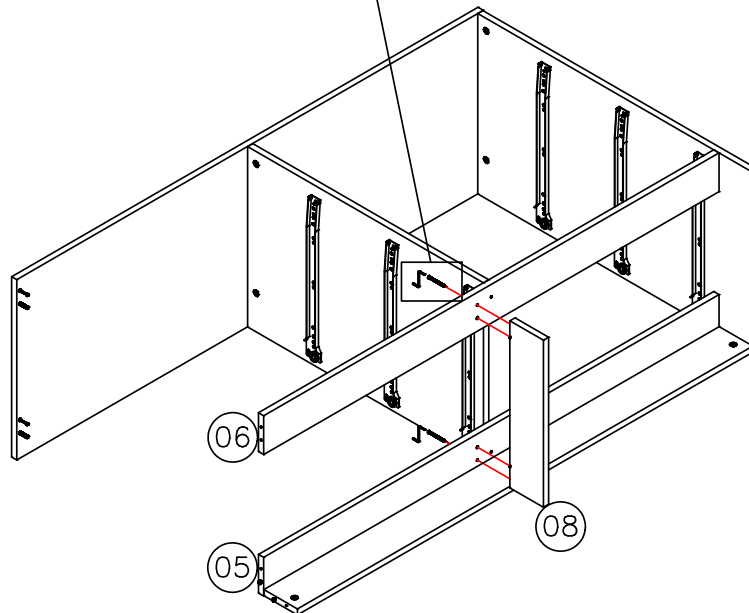
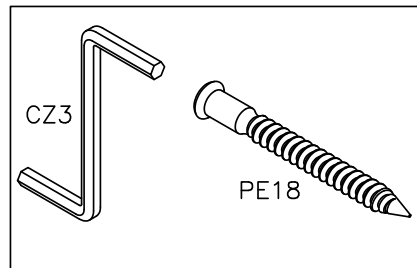



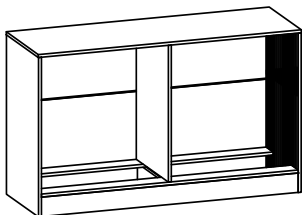
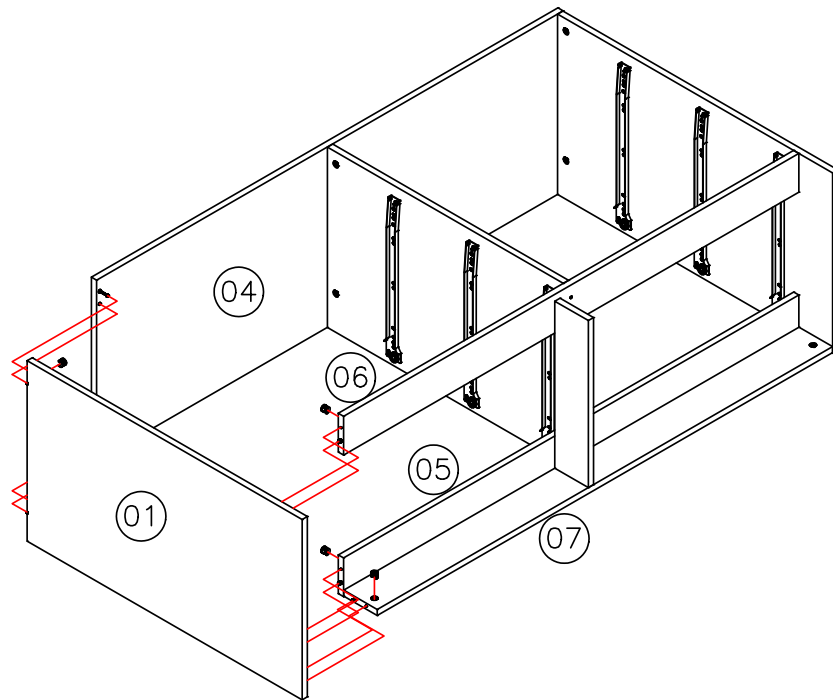
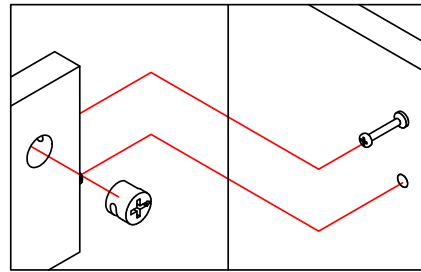
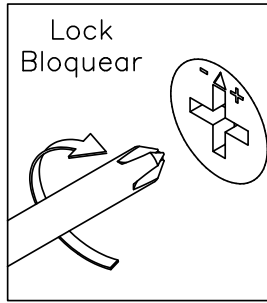
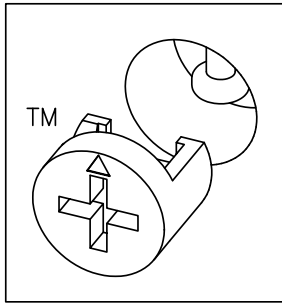
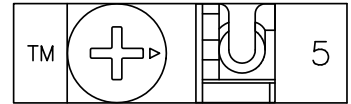

13

Product Assembly

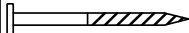

14

Product Assembly

PR2		6
SD		6
CG		1
PC3		4

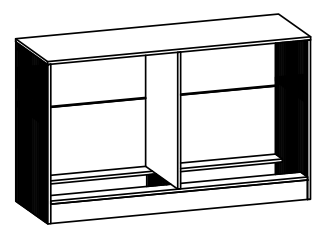
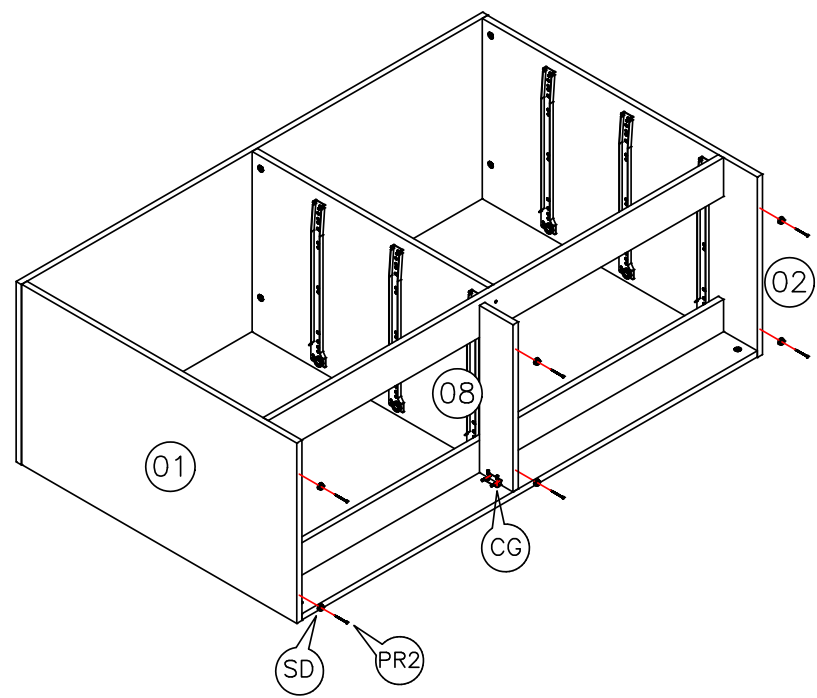
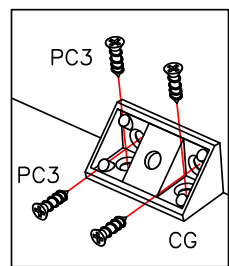
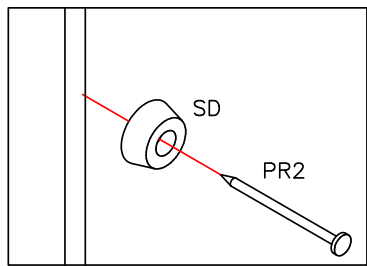

15

Product Assembly



Attention: Ensure that when nailing the back parts in place, that it is being nailed as straight as possible to the top and sides.

Failure to do so can make the drawers appear crooked.

PR1		40
PH		2

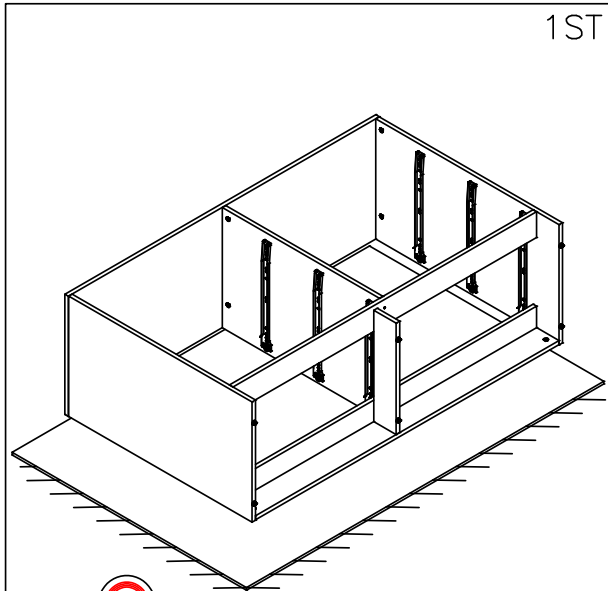

1ST

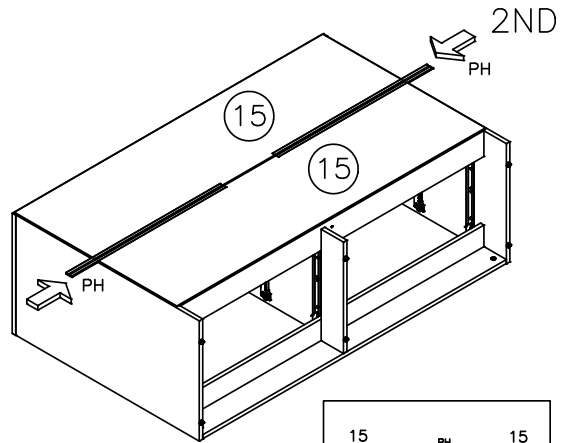

2ND

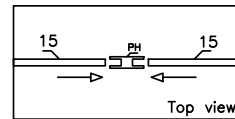

Carefully place the furniture on its front, on top the box in which it came to protect it when attaching the back panel.

Note: It is essential to place the furniture straight/squared to avoid problems with the functioning and alignment of the Drawers and Doors.

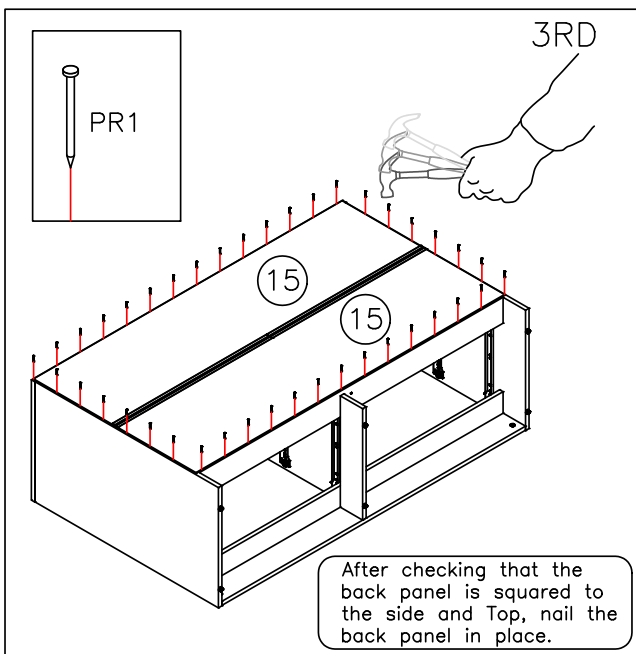

3RD

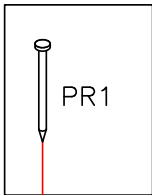

After checking that the back panel is squared to the side and Top, nail the back panel in place.

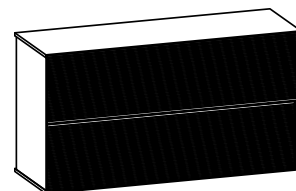
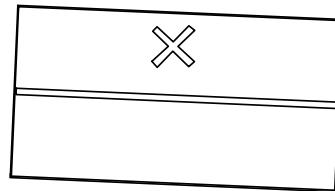
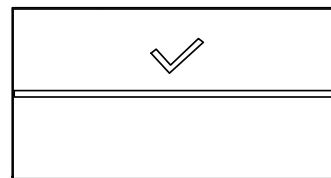

16

Product Assembly

 **Drawer installation**
 Insert the side into the profile and close the drawer to finish locking the clip.

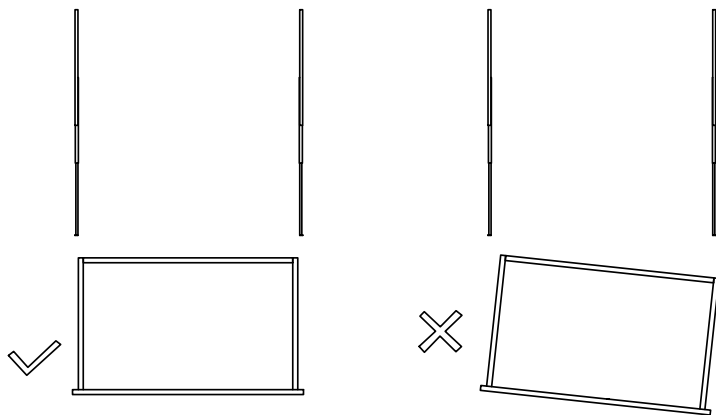
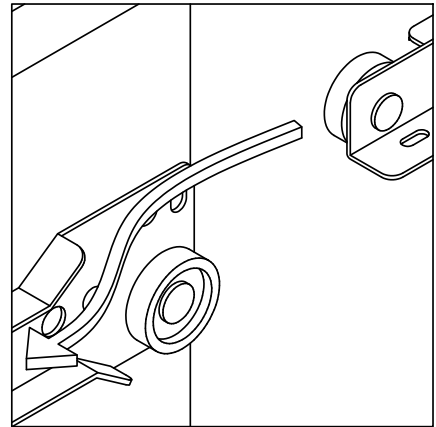
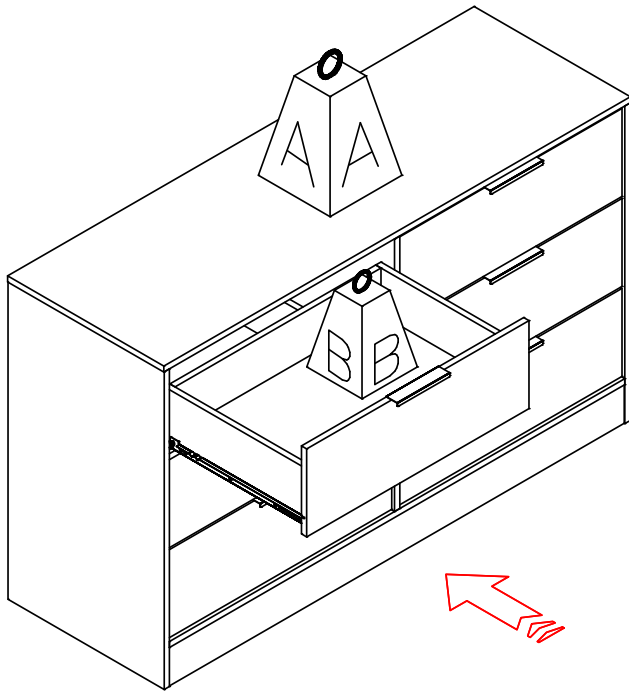

	Kg	lb
A	35	77.16lb
B	6	13.23lb

17

NOTE: Do not turn the DRYWALL ANCHOR into a wall stud. If you prefer to fasten the SAFETY ANTI-TIPPING to a wall stud, go to your local hardware store for proper hardware.

Compress the wings of anchor before inserting.

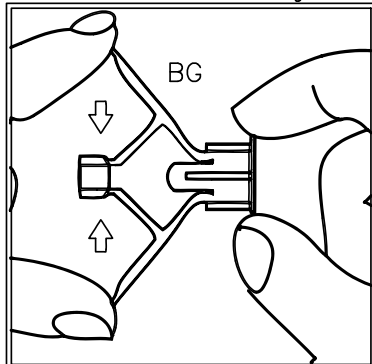

Insert the chuck into the hole of the base material.

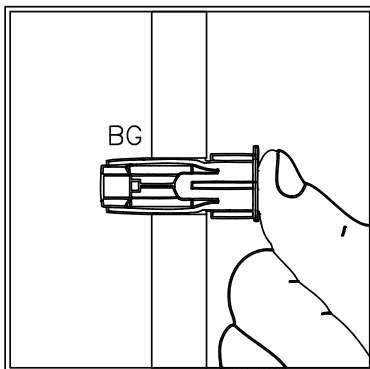

Position the object over the bushing and secure it with a screw.

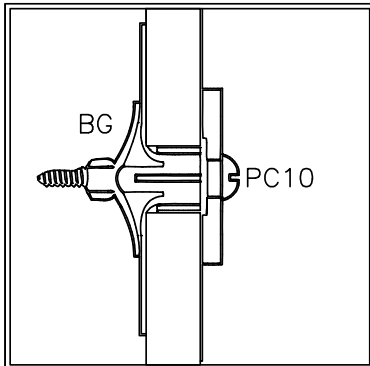

Anti-tipping installation			
SF		Mounting bracket	2
ANY		Clamp	1
PC10		Screw 4,5x50	2
PF4		Screw 3,5x16 BC	2
BG		Anchor	2

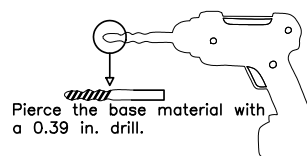
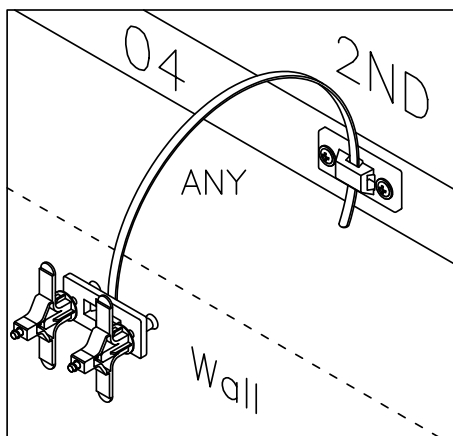
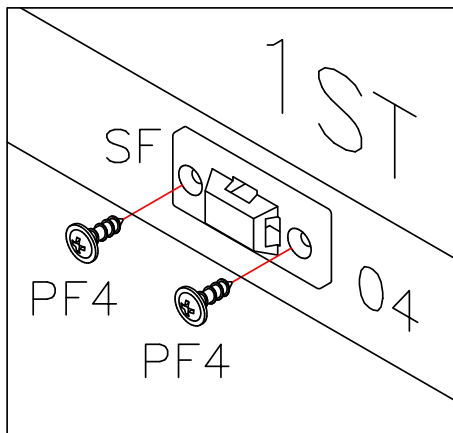

Pierce the base material with a 0.39 in. drill.

Important

- The minimum length of the screw must be the bushing length + object thickness that will be fixed.
- To guarantee the wing expansion function of the bushing, after the screw head is at the object to be fixed, one must continue to rotate the screw until maximum torque is reached.

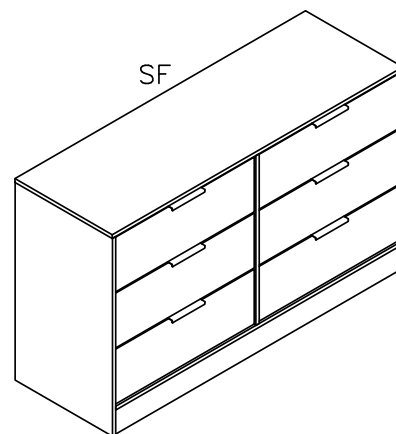

▲ WARNING –Anti-Tip Advisory

Potential of serious fatal crushing injuries may occur from furniture tip-over. To help prevent tip-over:

ALWAYS INSTALL the tip-over restrain that came with your furniture. This tip-over restrains only reduces but does NOT completely eliminate the risk of tip-over

- ALWAYS Place the heaviest items in the lowest/bottom drawer.
- NEVER place heavy objects on top of this product.
- NEVER allow children to scale/climb/hang on the drawers, doors, or shelves.
- NEVER open more than one drawer at a time.

B ADVERTENCIA – Aviso antivuelco

Pueden producirse lesiones graves por aplastamiento mortales debido al vuelco de los muebles. Para ayudar a prevenir vuelcos:

- o SIEMPRE INSTALE el sistema de retención que viene con sus muebles. Este sistema antivuelco solo reduce pero NO elimina por completo el riesgo de vuelco.
- o SIEMPRE coloque los artículos más pesados en el cajón más bajo /inferior.
- o NUNCA coloque objetos pesados encima de este producto.
- o NUNCA permita que los niños escalen, trepen o se cuelguen de los cajones, puertas o estantes.
- o NUNCA abra más de un cajón a la vez

18

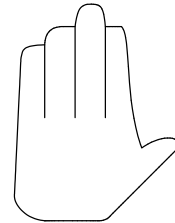
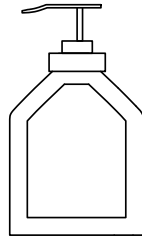
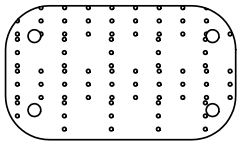

To Remove the printed number, apply a small amount of Glass Cleaner or Hand sanitizer and wipe with a paper towel.

