

Assembly Instructions

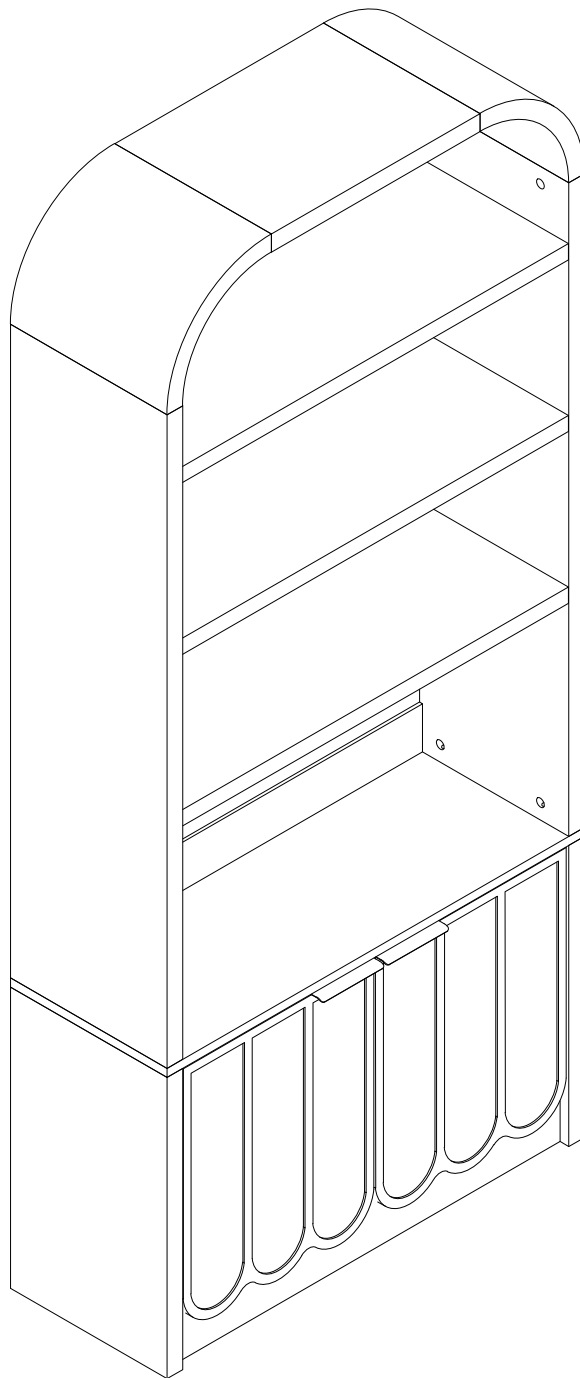

Before Assembly

Tips Before Your Start:

- Remove all wrapping material, including staples & packing straps before you start to assemble.
- DO NOT tighten all screws and bolts until the assembly is completely assembled.
- Keep all hardware parts out of reach of children.

QUICKFIT

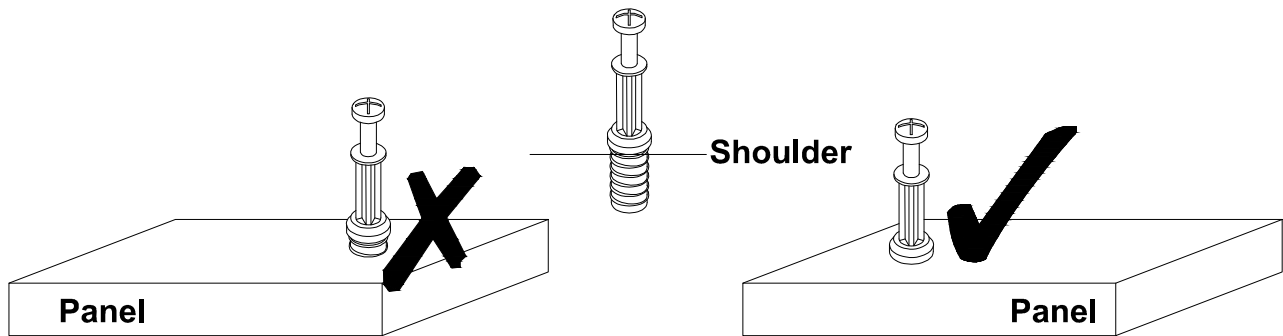

Tighten quickfit until shoulder is flush with panel. Do not overtighten or undertighten.

CAM LOCK

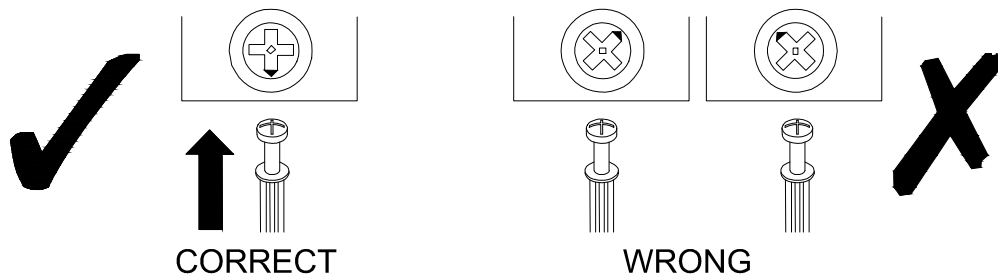

When fitting a cam lock, ensure the starting position is correct before inserting the connecting QUI CKFIT





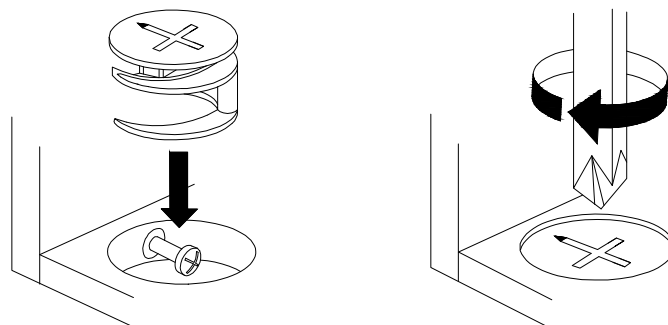

Quickfit head should be in the centre of the cam lock when the two panels are joined.

Cam lock should be inserted before quickfit.

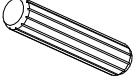
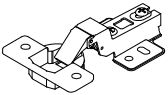

Turn cam lock clockwise to tighten.

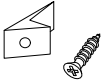
Part List

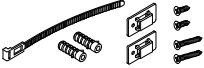
<p>No. A Quantity:53 Pcs Cam Lock Dowel 8*28mm</p> 	<p>No. B Quantity:53 Pcs Cam φ15</p> 	<p>No. C Quantity:53 Pcs Sticker Ø20</p> 	<p>No. D Quantity:22 Pcs Dowel 8*30mm</p> 
<p>No. E Quantity:4 Pcs Hinge</p> 	<p>No. F Quantity:2 Pcs Handle</p> 	<p>No. G Quantity:28 Pcs Screw M3.5*12mm</p> 	<p>No. H Quantity:18 Sets Plastic Wedge</p> 
<p>No. I Quantity:4 Pcs Foot Pad Ø15</p> 	<p>No. J Quantity:1 Sets Anti-falling Parts</p> 		

Product structure

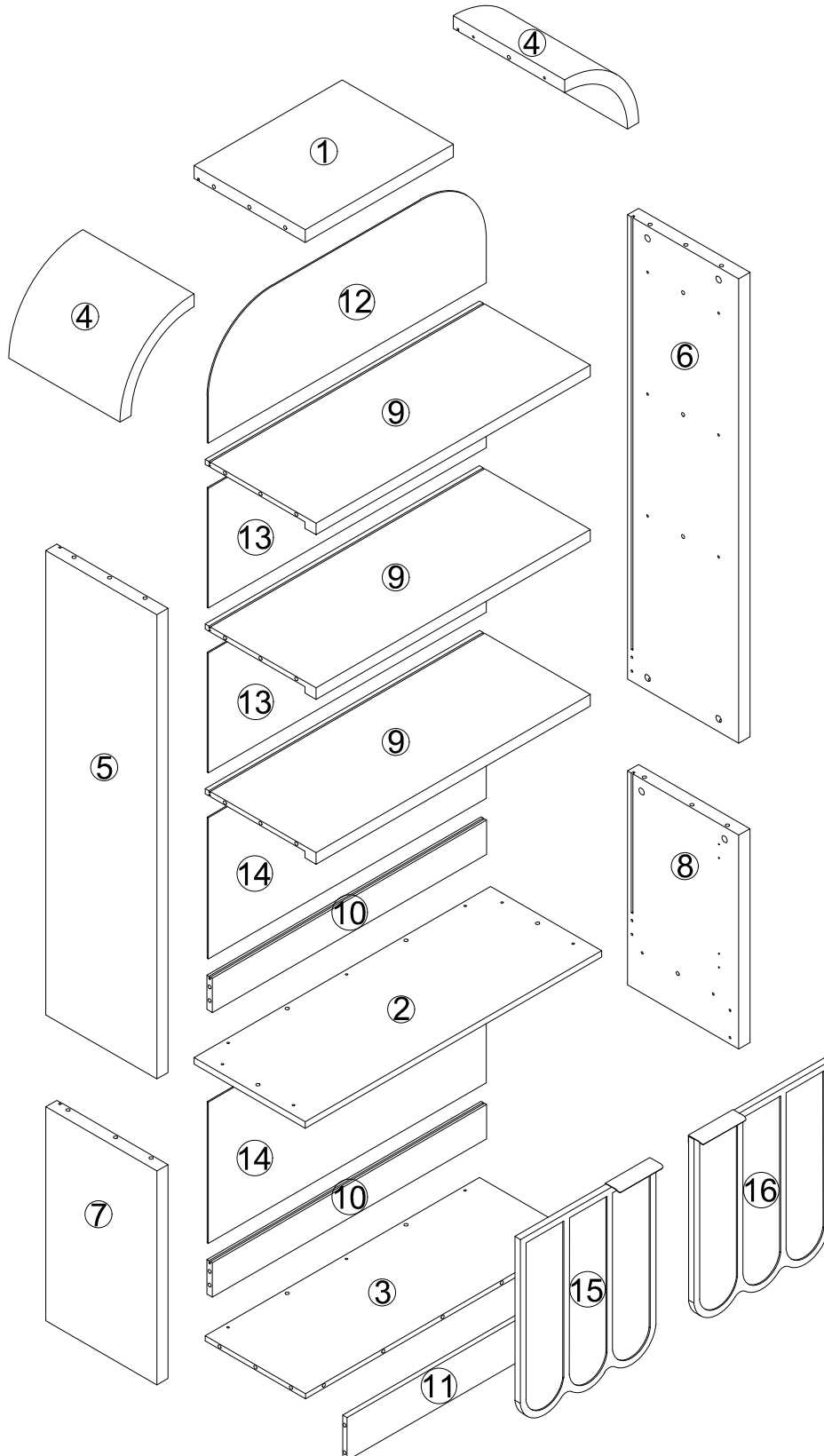

STEP 1

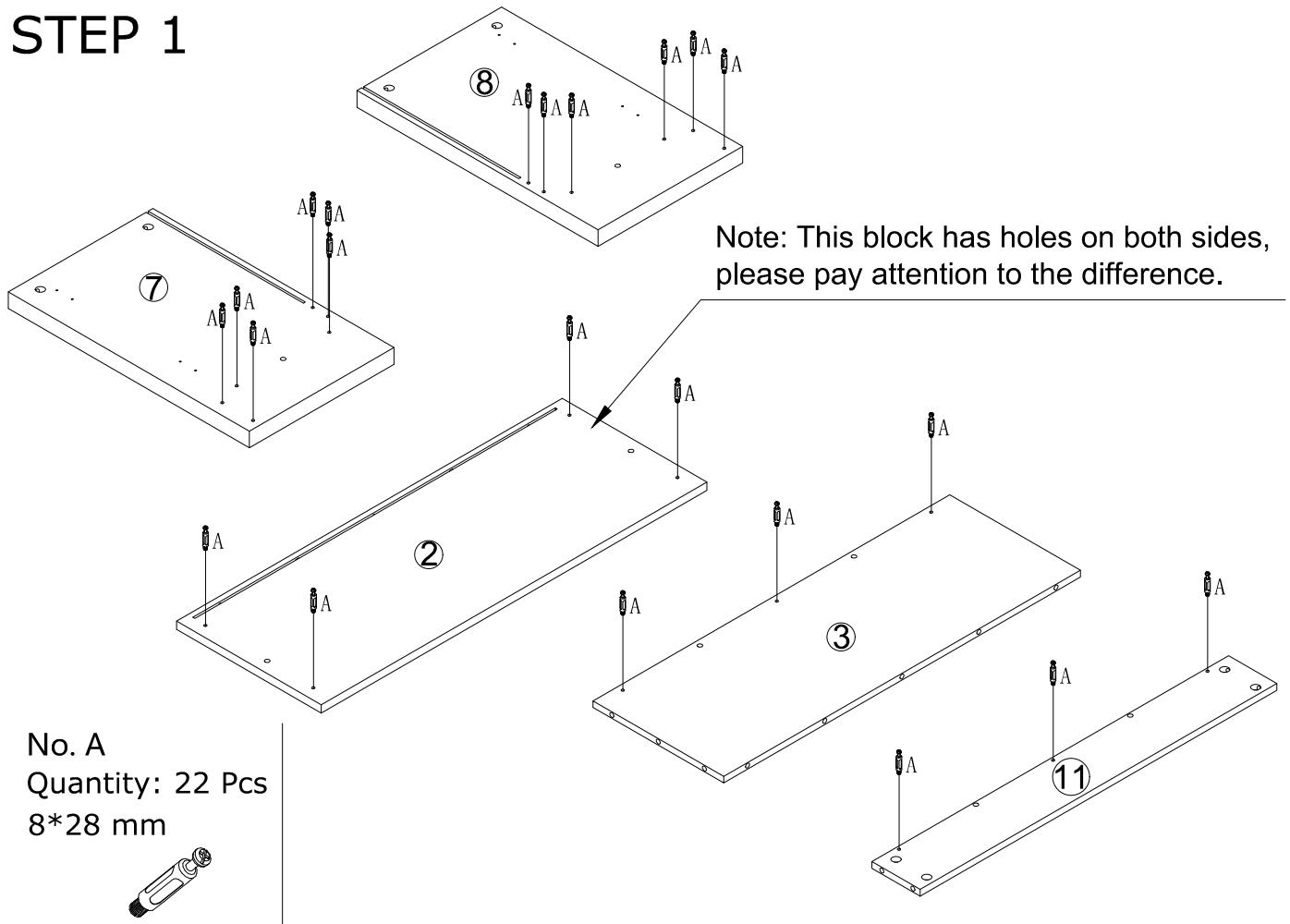

STEP 2

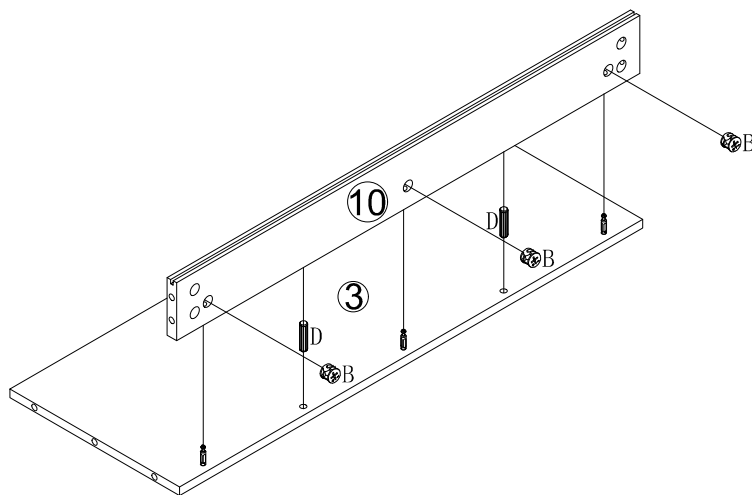

No. B
Quantity: 3 Pcs
Ø15



No. D
Quantity: 2 Pcs
8*30mm

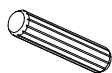

STEP 3

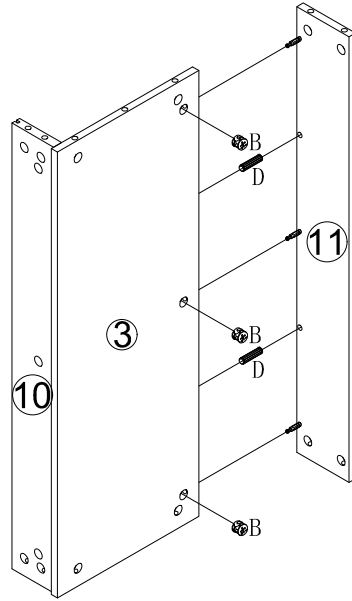

No. B
Quantity: 3 Pcs
Ø15



No. D
Quantity: 2 Pcs
8*30mm

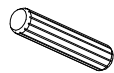

STEP 4

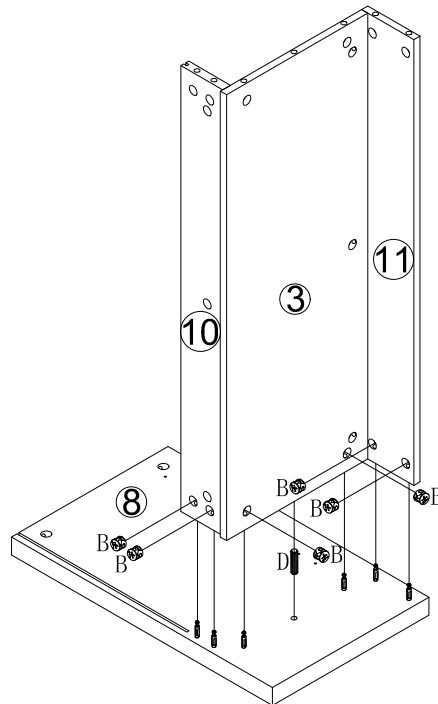

No. B
Quantity: 6 Pcs
Ø15



No. D
Quantity: 1 Pcs
8*30mm

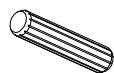

STEP 5

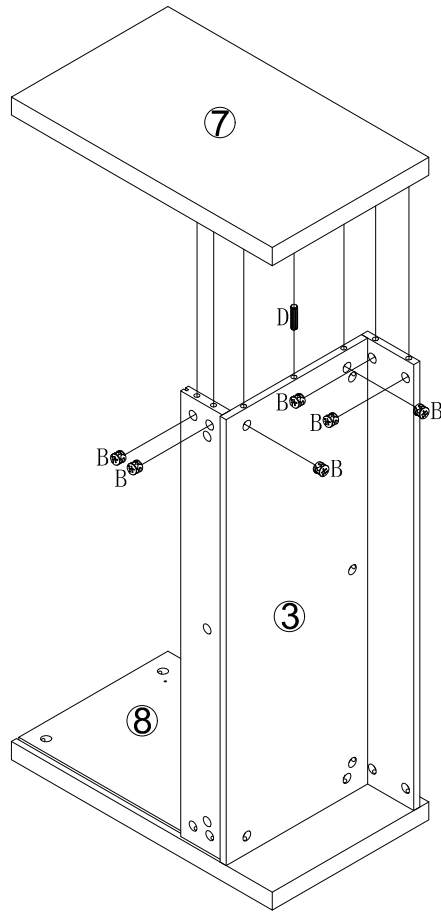

No. B
Quantity: 6 Pcs
Ø15



No. D
Quantity: 1 Pcs
8*30mm

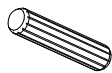

STEP 6

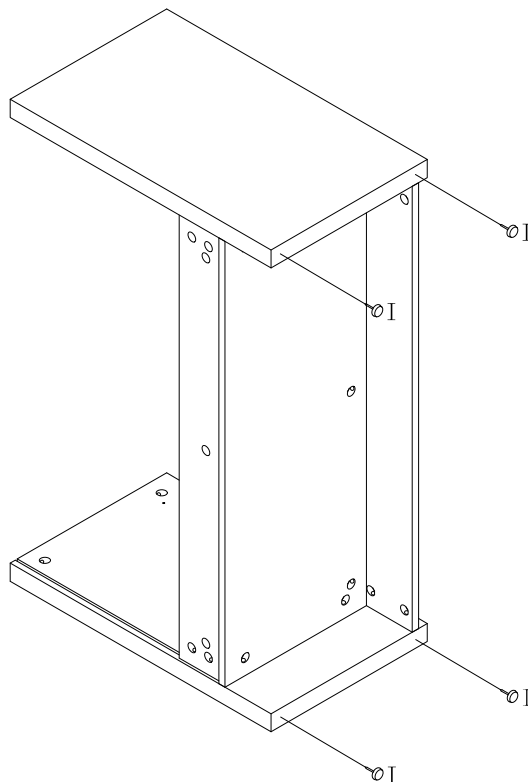

No. I
Quantity: 4 Pcs
Ø15



STEP 7

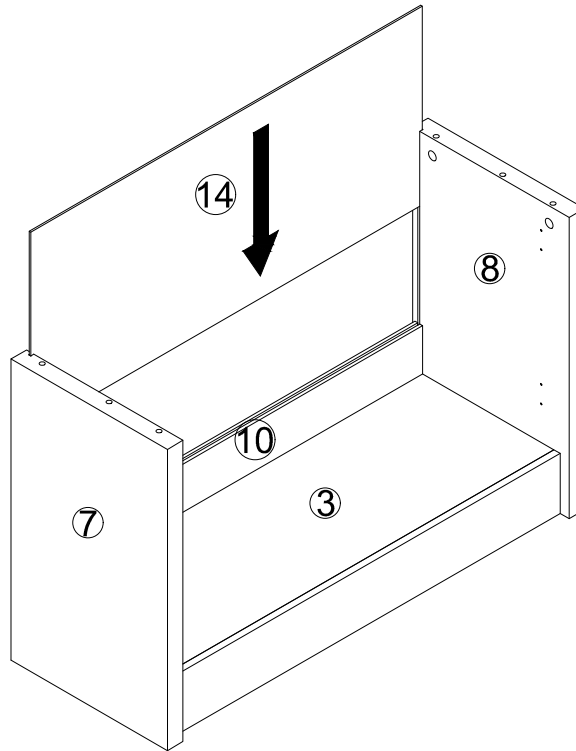

STEP 8

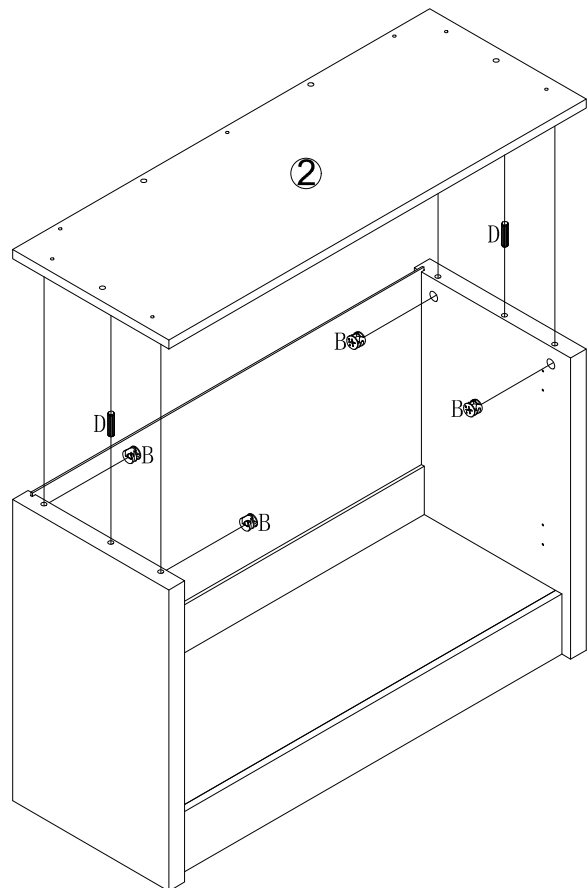

No. B
Quantity: 4 Pcs
Ø15



No. D
Quantity: 2 Pcs
8*30mm

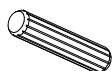

STEP 9

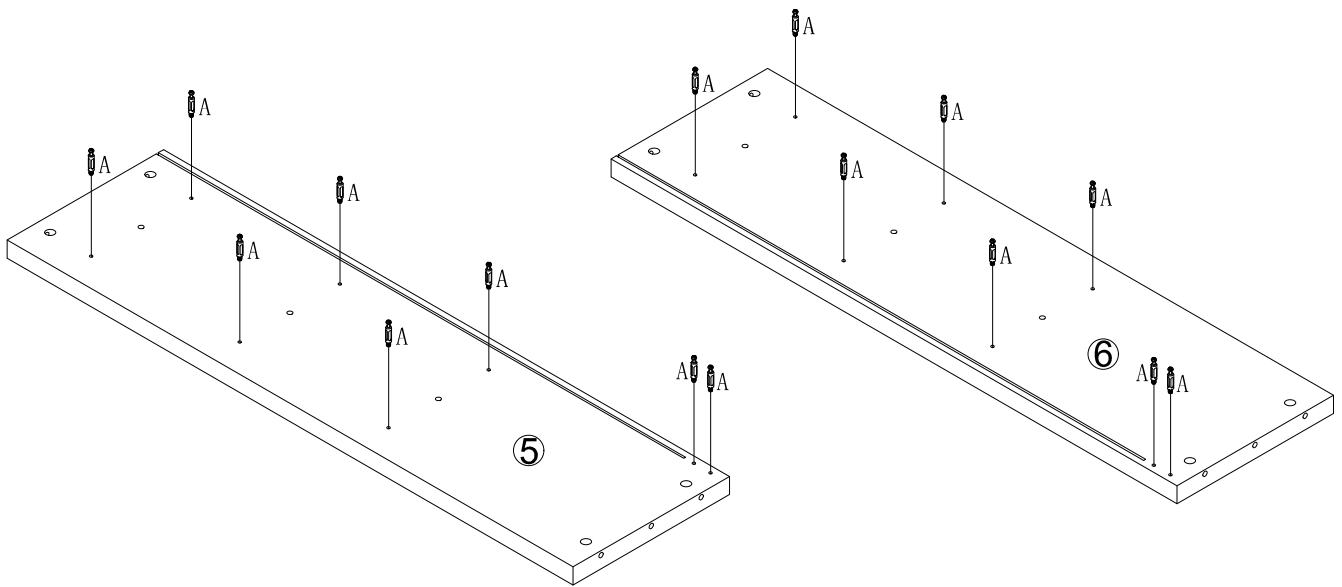

No. A
Quantity: 16 Pcs
8*28 mm



STEP 10

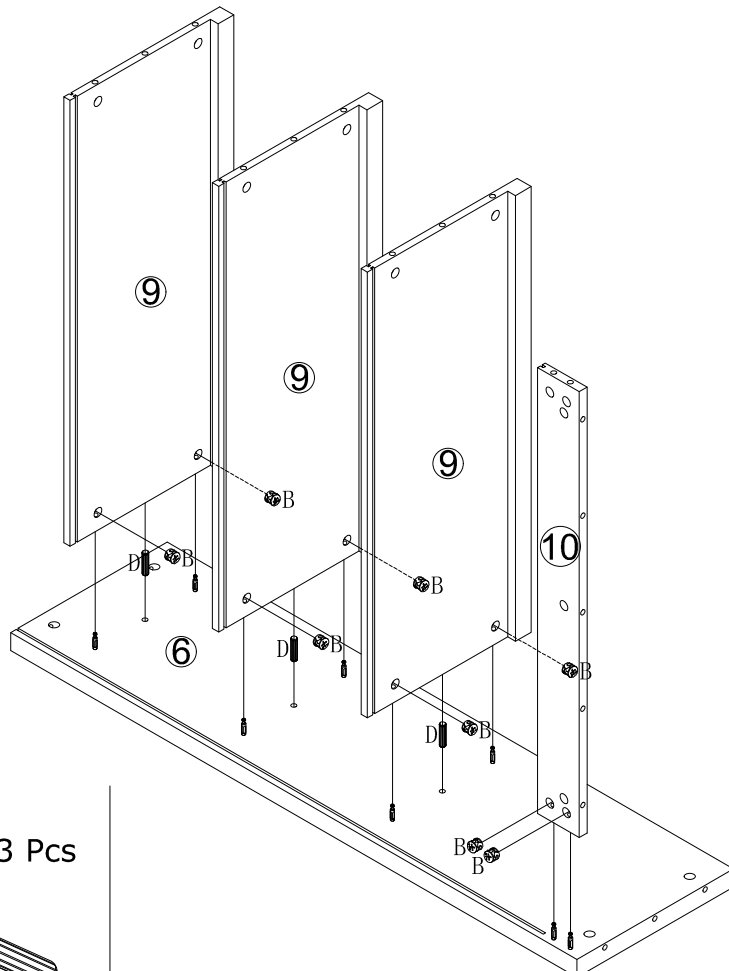

No. B
Quantity: 8 Pcs
Ø15



No. D
Quantity: 3 Pcs
8*30mm

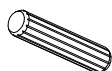

STEP 11

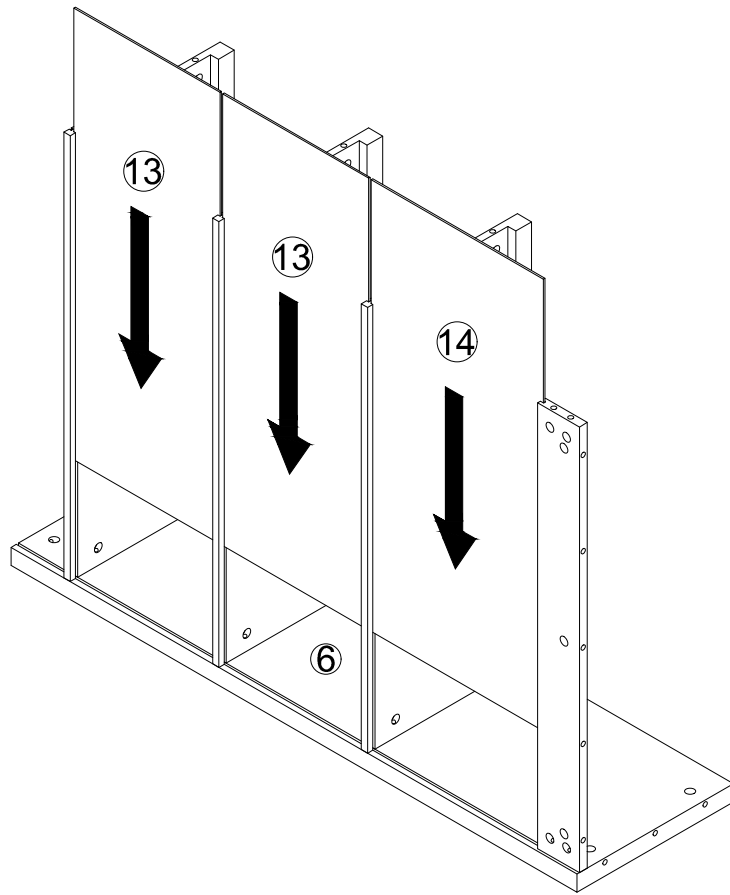

STEP 12

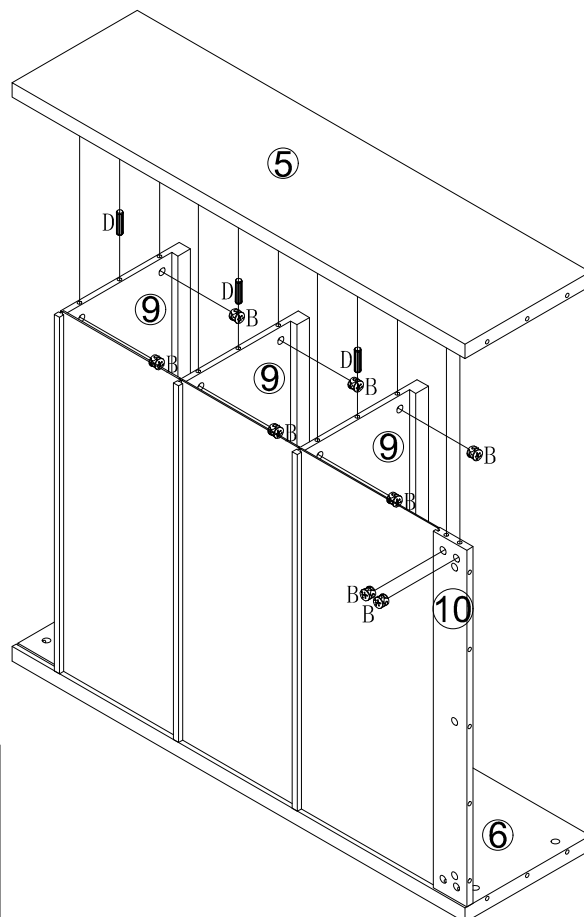

No. B
Quantity: 8 Pcs
Ø15



No. D
Quantity: 3 Pcs
8*30mm

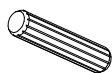

STEP 13

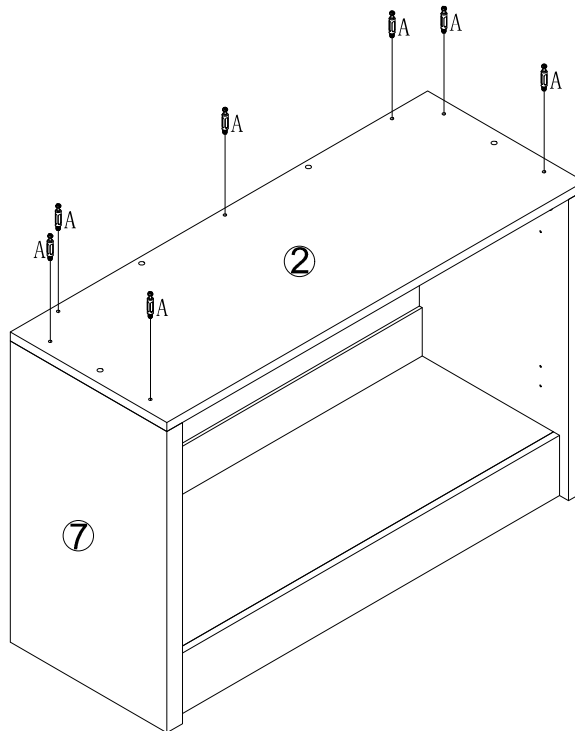

No. A
Quantity: 7 Pcs
8*28 mm



STEP 14

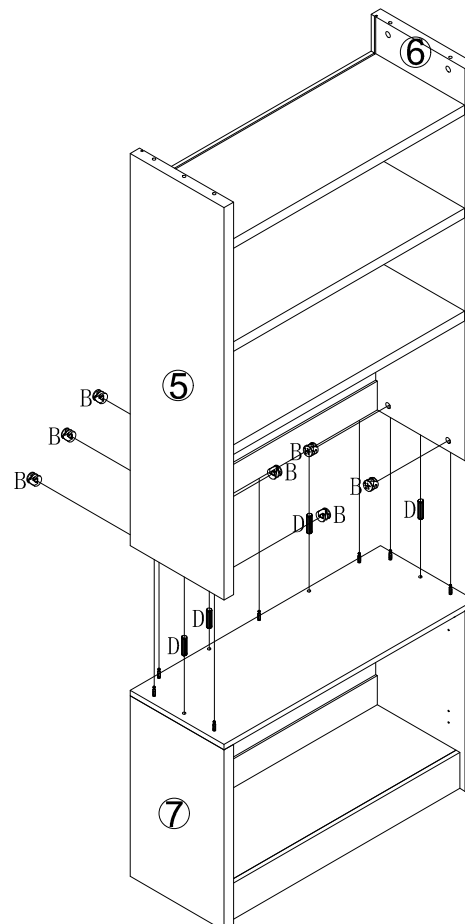

No. B
Quantity: 7 Pcs
Ø15



No. D
Quantity: 4 Pcs
8*30mm

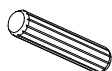

STEP 15

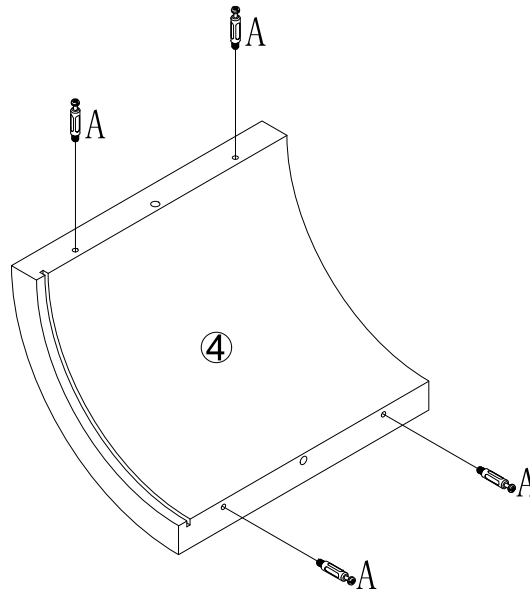

No. A
Quantity: 8 Pcs
8*28 mm



x2

STEP 16

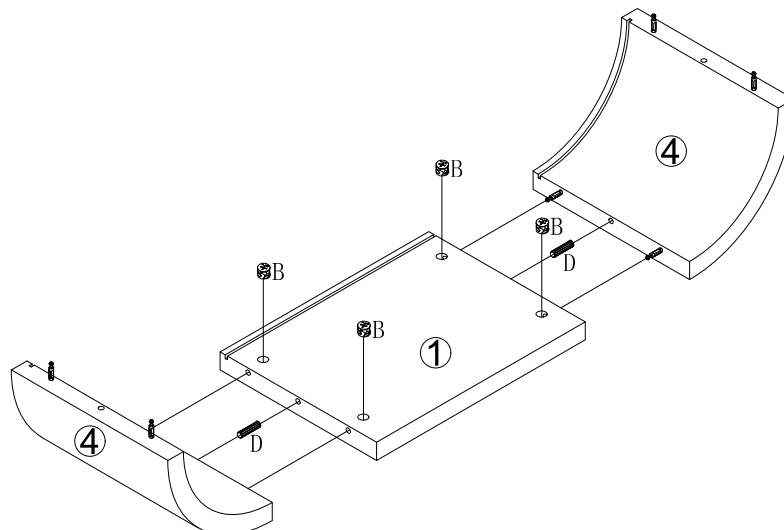

No. B
Quantity: 4 Pcs
Ø15



No. D
Quantity: 2 Pcs
8*30mm

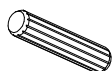

STEP 17

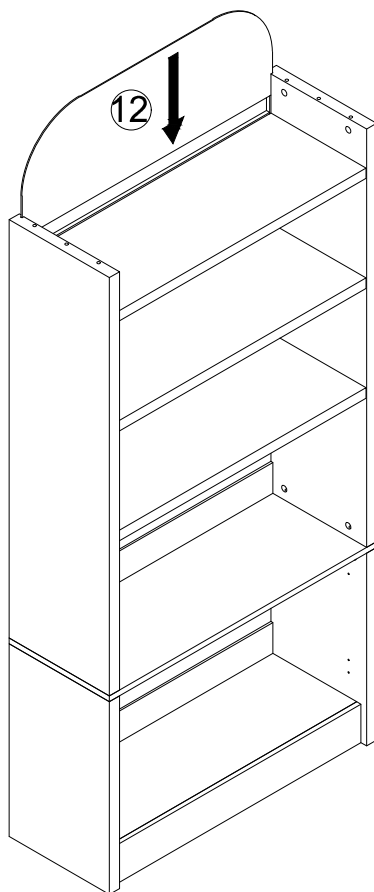

STEP 18

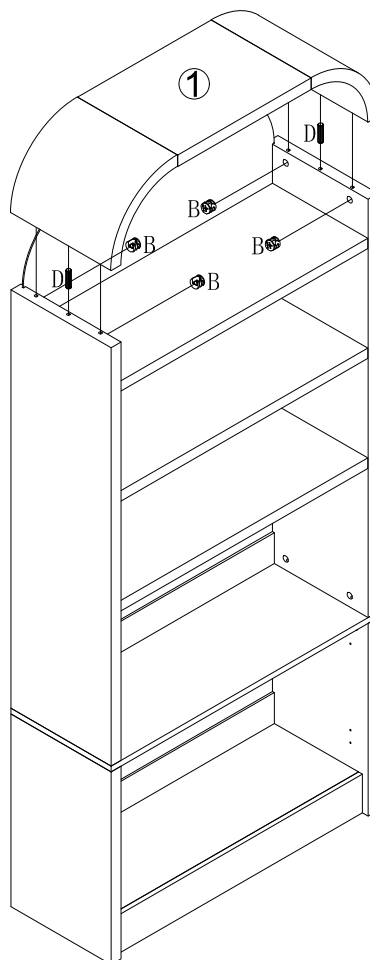

No. B
Quantity: 4 Pcs
Ø15



No. D
Quantity: 2 Pcs
8*30mm

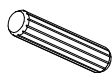

STEP 19

No. E
Quantity: 4 Pcs

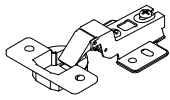

No. F
Quantity: 2 Pcs

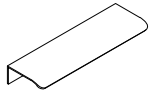

No. G
Quantity: 12 Pcs
M3.5*12mm

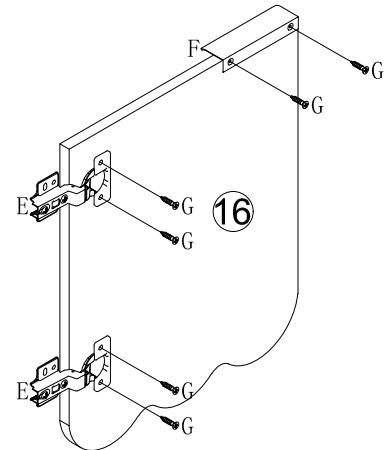
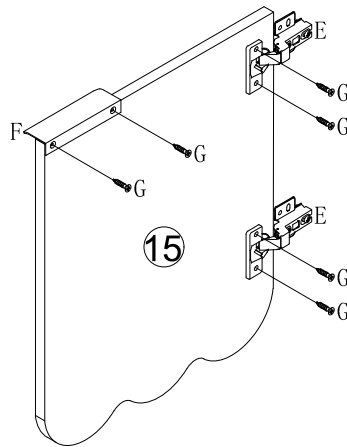

STEP 20

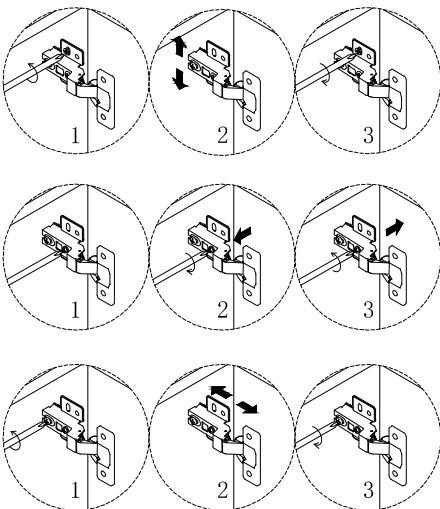

No. G
Quantity: 16 Pcs
M3.5*12mm

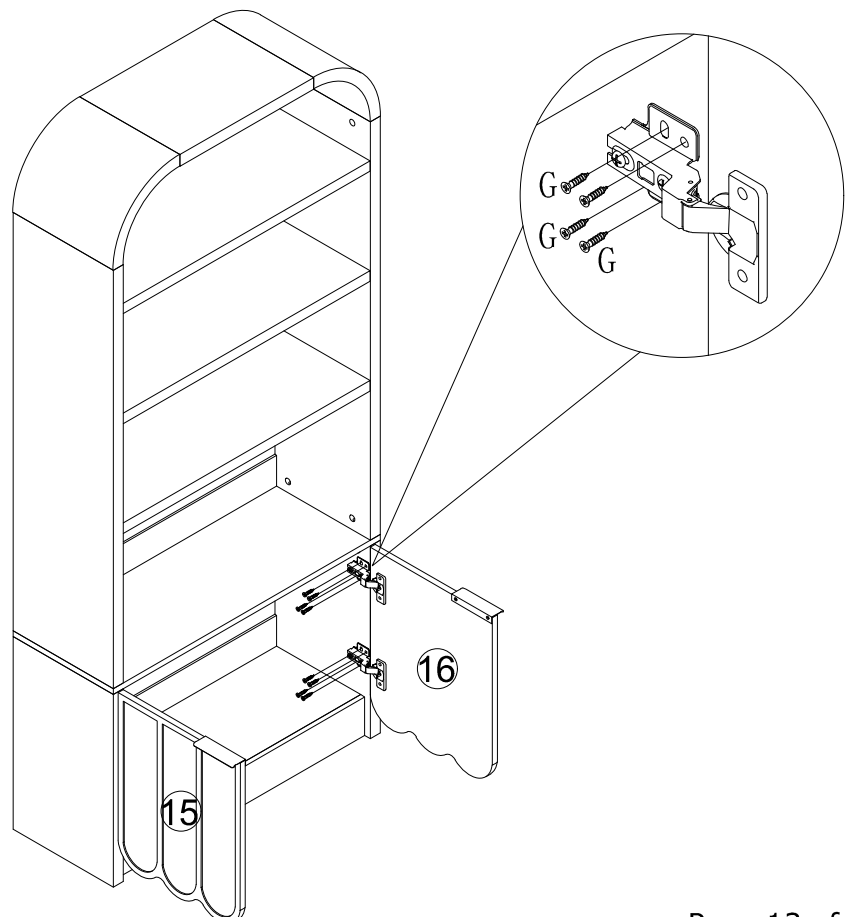

STEP 21

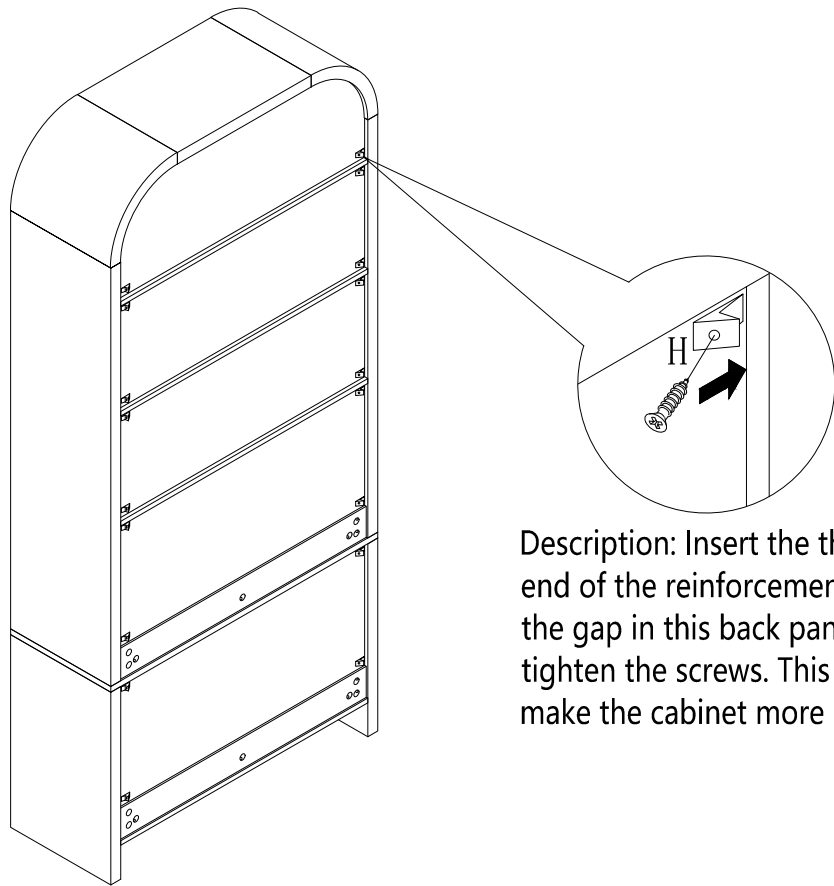

Description: Insert the thinner end of the reinforcement into the gap in this back panel, then tighten the screws. This will make the cabinet more stable.

No. H
Quantity: 18 Sets

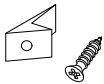

STEP 22

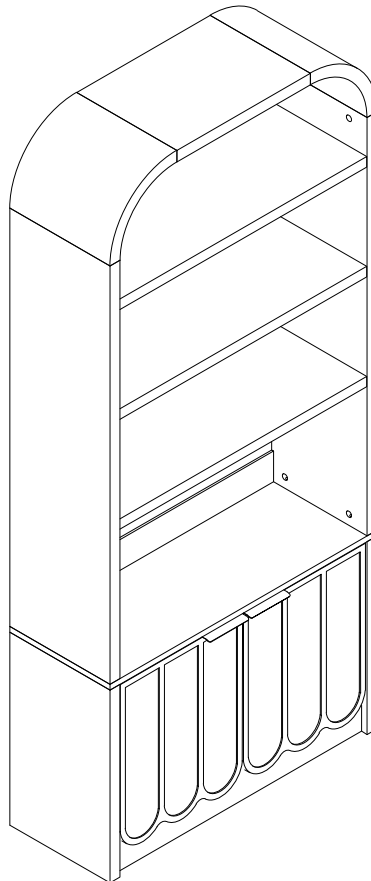

STEP 23

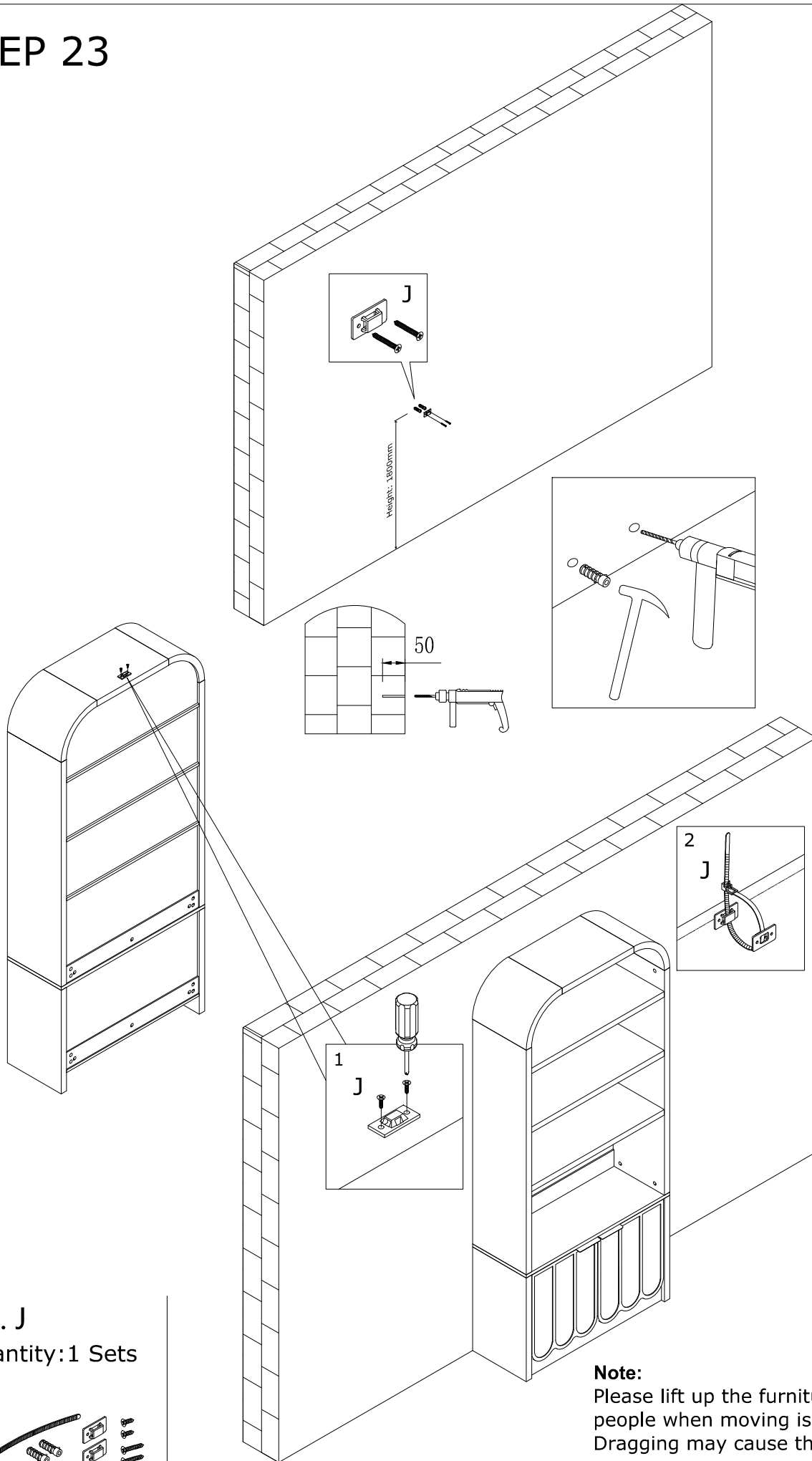

No. J
Quantity: 1 Sets

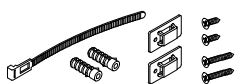

Note:
Please lift up the furniture by two people when moving is needed.
Dragging may cause the legs failure.