



Food Waste Disposers

QUIET SERIES

Evolution Essential® XTR

With SinkTop Switch™ activation included.



Submittal Sheet

This model offers the following features and benefits:

- **Lift & Latch™** technology for easier sink connection.
- **2-Stage MultiGrind®** technology for tougher food scraps like chicken bones.
- **Highest Durability.** Alloy stainless steel components with LeakGuard Liner.™
- Advanced noise reduction with insulated **SoundSeal® Technology.**
- Includes SinkTop Switch™ accessory with Satin Nickel button for easy disposer activation, and power cord accessory. Quiet Collar® sound reducing sink baffle also included.

Specifications

Type of Feed	Continuous
On/Off Control	SinkTop Switch™
Motor	Single Phase
HP	3/4
Volts	120
HZ	60
RPM	1725
Amp. (Avg. Load)	8.1
Time Rating	Intermittent
Lubrication	Permanently Lubricated Upper & Lower Bearings
Shipping Weight (Approx.)	20.0 lbs.
Unit Finish	Black Enamel Gray
Overall Height	12-1/4"
SoundSeal Technology	Anti-Vibration Mount® Anti-Vibration Tailpipe Mount™ Quiet Collar® Sink Baffle SoundLimiter® Insulation
MultiGrind Technology	GrindShear Ring®
Grind Chamber Capacity	34.6 oz.
Motor Protection	Manual Reset Overload
Average Water Usage	Approx. 1 Gallon Per Person Per Day
Average Electrical Usage	3-4 KWh Per Year
Drain Connection	1-1/2" Anti-Vibration (Hose Clamp)
Dishwasher Drain Connection	Yes

Dimensions

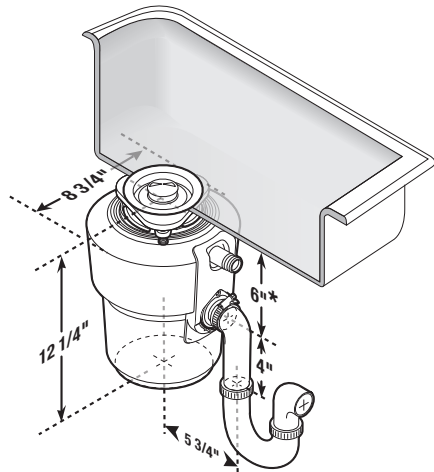

* Add 1/2" when stainless steel sinks are used.

Sample Specification

Food Waste Disposer(s) shall be InSinkErator Model Evolution Essential® XTR with MultiGrind® and SoundSeal® technologies, 3/4 HP motor, Stainless Steel Grind components, SinkTop Switch™ accessory and power cord accessory.

Warranty:

9-Year parts and in-home service.

* The complete InSinkErator warranty is included in the Care & Use Booklet packed with each unit.



Food waste is roughly 80% water. By using your disposal regularly, you can help divert food waste from landfills and reduce greenhouse gas emissions. Make sustainability a family affair by using your disposal. After all, the smallest changes can make the biggest impact.

Job Specifications

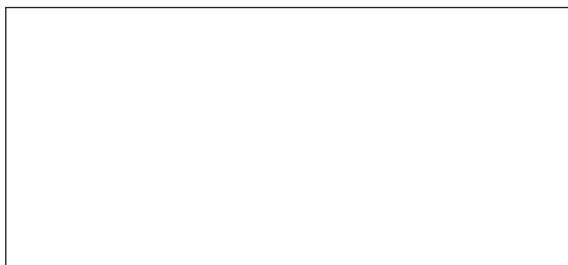

The Emerson logo is a trademark and service mark of Emerson Electric Co. The mounting collar configuration is a trademark of Emerson Electric Co.

InSinkErator may make improvements and/or changes in the specifications at any time, in its sole discretion, without notice or obligation and further reserves the right to change or discontinue models.

1-800-558-5700
www.insinkerator.com