

Assembly Instruction

Caution: You must read this before you proceed

Table

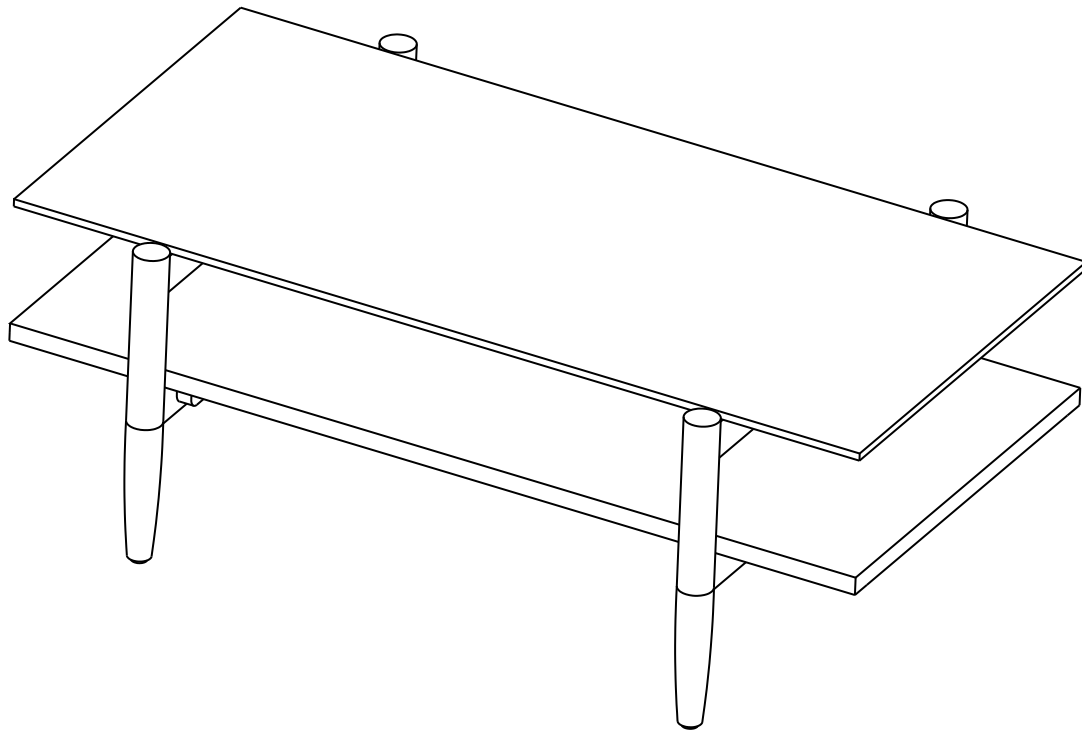

Caution: This Table is NOT a TOY.

Keep your child/children at bay during the assembly process.

Whenever moving/lifting the Table and to prevent damage to the Table, two adults are needed to execute these actions.

Parts List

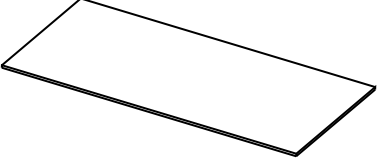
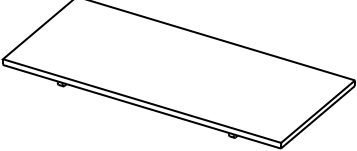
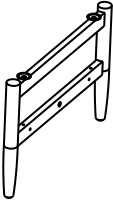
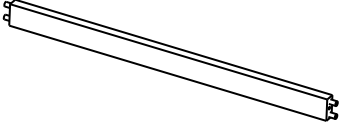
Label	Picture	Description	QTY
A		Table Top (glass)	1
B		Shelf	1
C		Leg Frame	2
D		Support Bar	1





Hardware

Label	Picture	Description	QTY
①		Screw (M7x60mm)	3
②		Bolt (M6x35mm)	5
③		Sleeve Nut (M6x15)	5
④		Bolt (M6x65mm)	5
⑤		Allen Key	2

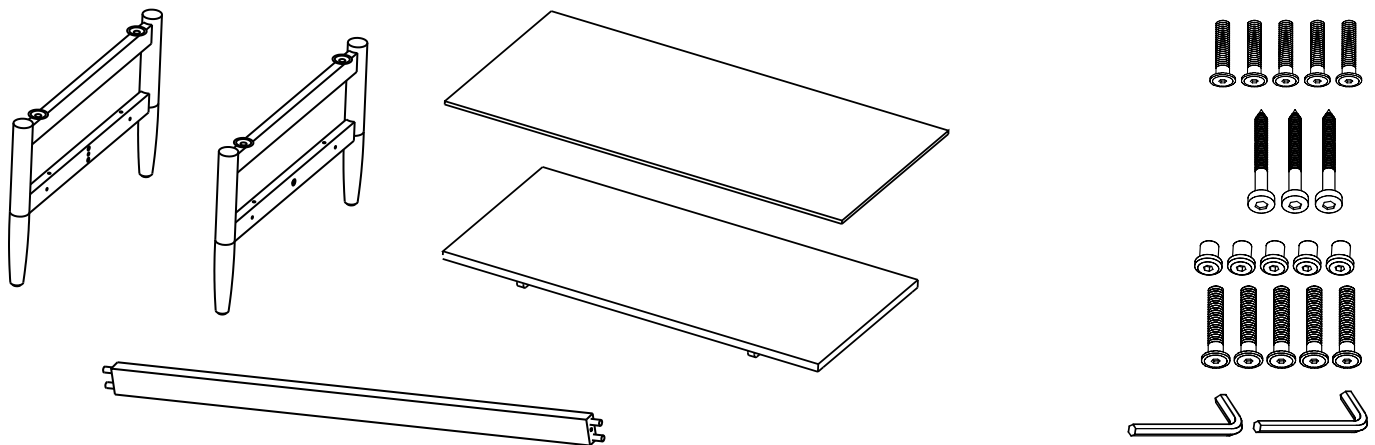
Assembly Preparation

Before Beginning Assembly:



-  • Read instructions, cover to cover-
-  • Have 2 adults on hand for assembly-
-  • Do not assemble on flooring or carpet-
-  • Assemble on a clean non-marring surface (packing foam)-
-  • Save all packaging until finished-

Assembly Steps

OVERVIEW

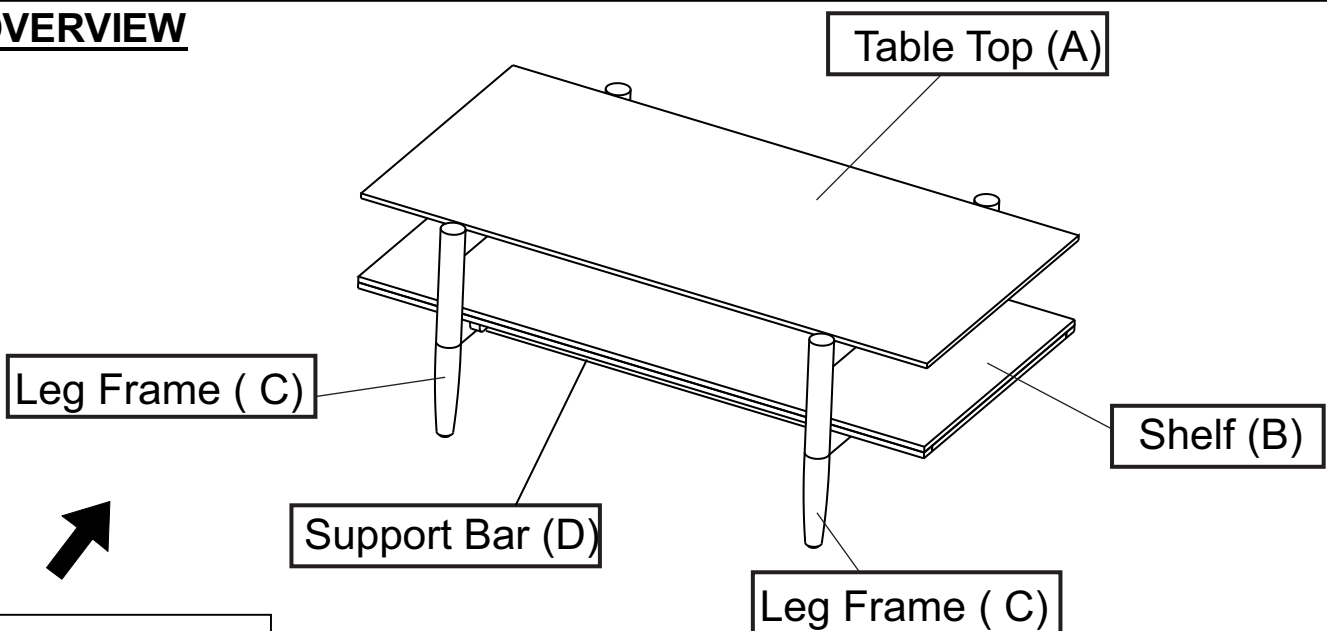

FRONT FACING

This Table has multiple parts and may require up to 30 minutes to assemble. To give you an overview of the Table parts, the above picture is to help you put the various parts into perspective. Please read through the instructions below to familiarise yourself with the parts and steps before assembly.

Step 1

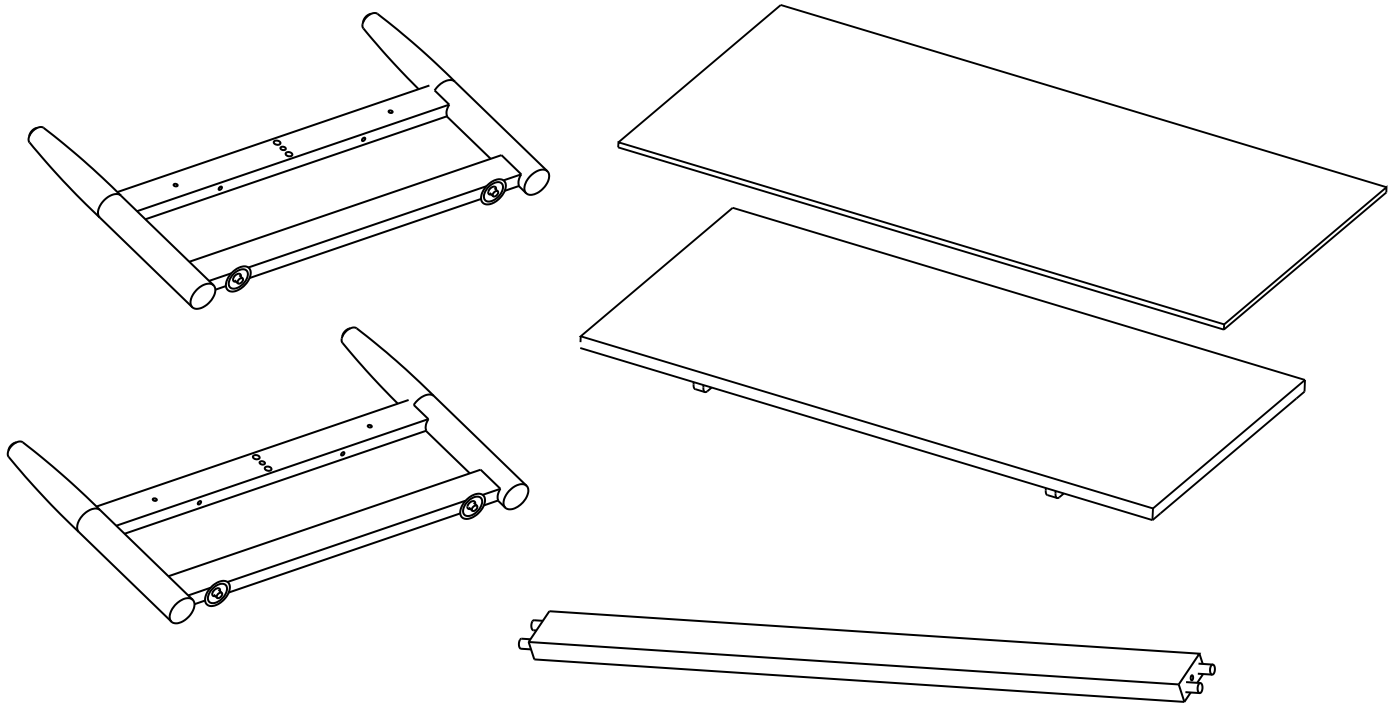

Unpack and place all parts on a clean, non-marring surface.

Step 2

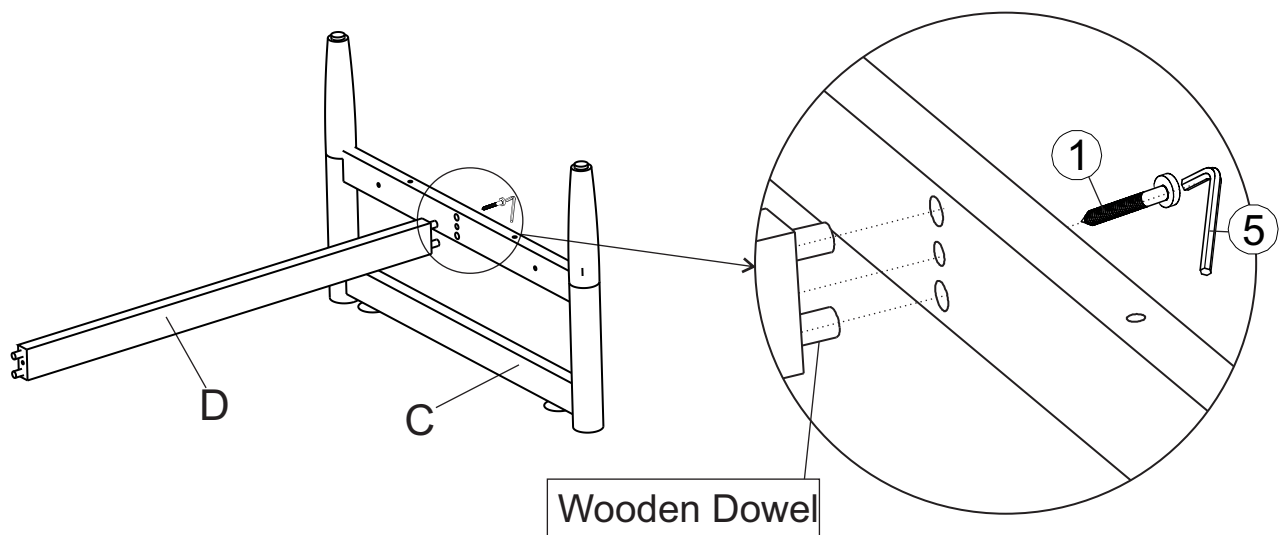

Place the Leg Frame (C) facedown on a clean, non-marring surface. Insert Wooden Dowel on Support Bar (D) into the housing of Leg Frame (C) and attach Leg Frame (C) to Support Bar (D) with Screws (①) using the Allen Key (⑤).

Do not fully tighten the Screws.

Repeat the same process with the remaining Leg Frame (C)

Step 3

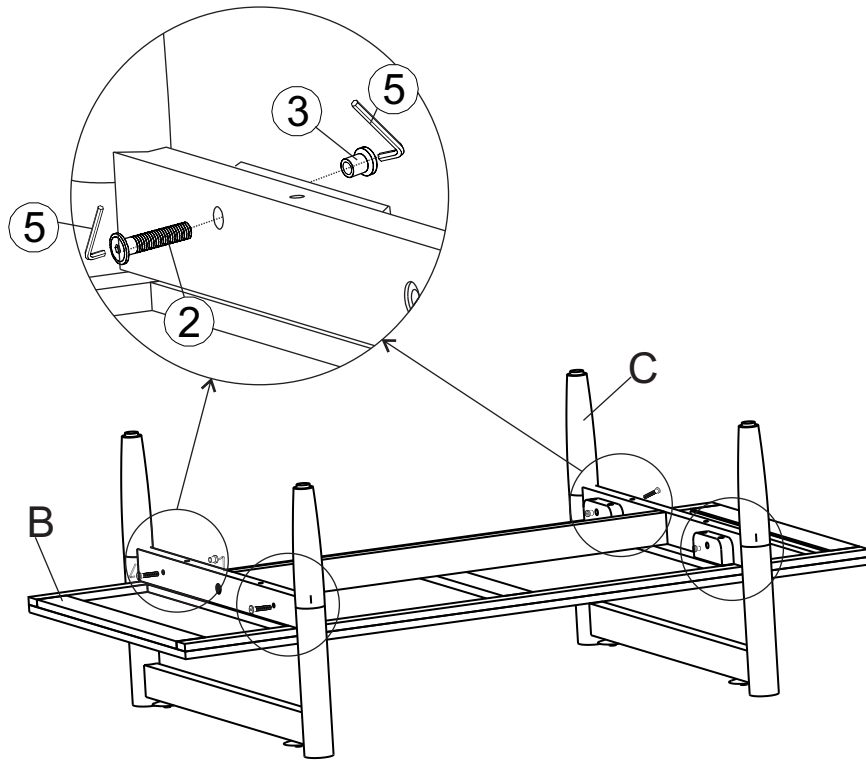

With assistance from your adult partner, position the Shelf (B) into the Leg Frames (C) as shown in the above picture.

Use the Allen Keys (⑤) to attach the Shelf (B) into the Leg Frames (C) with Bolts (②) and Sleeve Nuts (③)

Do not fully tighten the Bolts.

Step 4

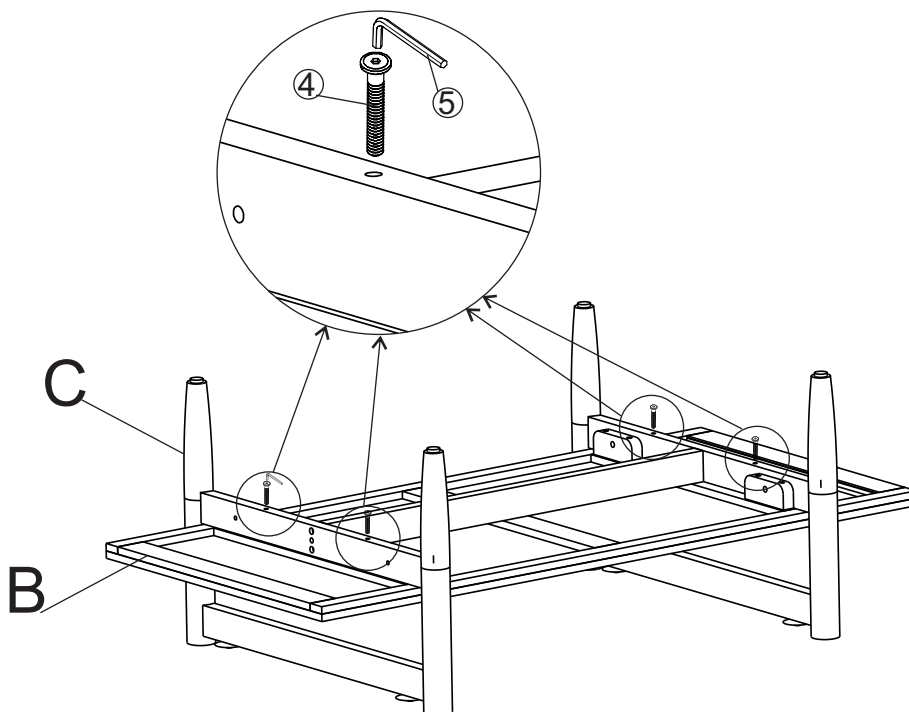

Using the Alen keys (⑤) secure Leg Frames (C) into Shelf (B) with Bolts (④).

Do not fully tighten the Bolts.

Step 5

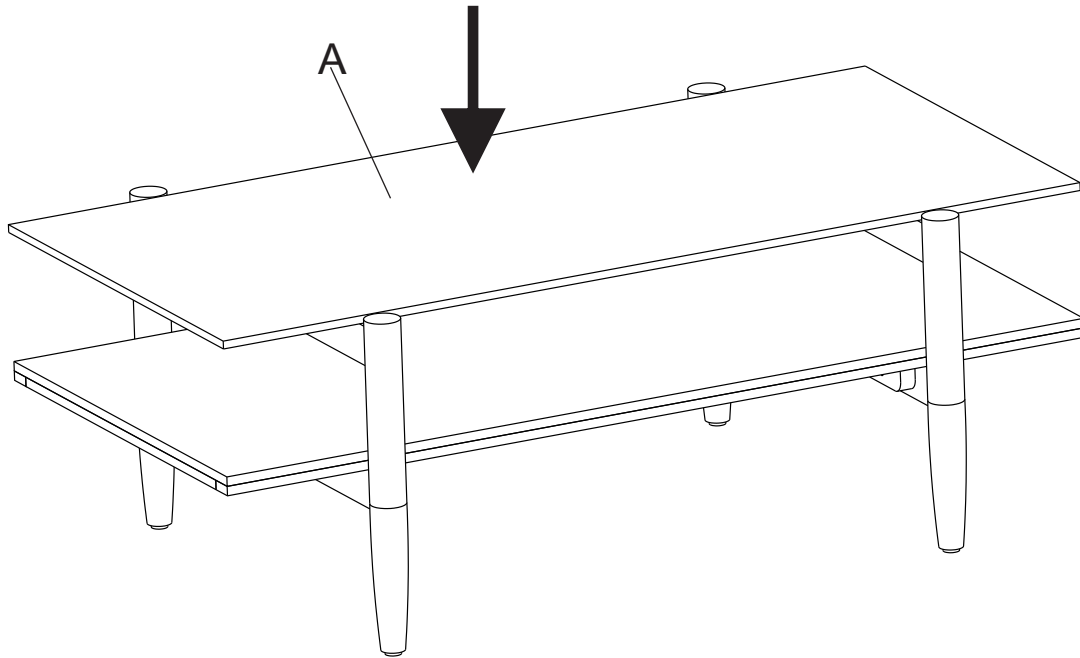

With assistance from your adult partner, stand up the table in step 4 then place the Table Top (A) onto it as shown above.

Exert pressure, push floorwards onto the Table with both hands.

This pressure will help the Table reach full alignment at all joints.

Check for wobbles on a LEVEL surface.

If no wobbles are found proceed to tighten the Bolts in a sequential manner, until evenly secured.

When tightening the Bolts tighten sequentially.

Do not tighten any Screws and Bolts fully and then move on towards the next one.











If there are still wobbles, loosen the Screws and Bolts and execute the above process again.

If the Table is not Stable it could lead to the product becoming damaged.

Your Table is ready for use.

This Table can only be used on a flat, level surface.

Care & Maintenance

-  Do not put hot items directly on furniture surface
 -  Do not clean furniture with harsh cleansers or polish.
 -  Do not place furniture under direct sunlight.
 -  Do not place furniture near heating or cooling vents.
 -  Do not write on furniture without a padded barrier to protect the surface.
 -  Do not place furniture outside . For indoor use only .
 -  Not for commercial use. For residential use only .
 -  Stains may be removed with mild soap solution and damp cloth.
 -  Children should not climb or jump on the furniture.
-
-  Dust and pick-up spills using a clean, non-colored, lint-free cloth .