

ASSEMBLY INSTRUCTION

Thank you for purchasing this quality product. Be sure to check all packing material carefully for small parts that may have come loose inside the carton during shipment.

TOOLS REQUIRED (NOT PROVIDED)

PHILLIPS SCREWDRIVER



Hardware packed with headboard/rails.

PART LISTS

NO.	Description	Sketch	Q'ty
1	HEADBOARD		1PC
2	HEADBOARD POST (L&R)		2PCS
3	HEADBOARD BOTTOM RAIL		1PC
4	FOOTBOARD		1PC
5	FOOTBOARD POST (L&R)		2PCS
6	SIDE RAIL		2PCS
7	SLAT		3PCS
8	SUPPORT LEG		3PCS

HARDWARE LISTS

NO.	Description	Sketch	Size	Q'ty
A	BOLT		5/16"*45mm	14PCS
B	ALLEN KEY		4mm	1PC
C	WOOD SCREW		25mm	6PCS
D	SPRING WASHER		5/16"*12D*2	14PCS
E	FLAT WASHER		5/16"*22D	14PCS

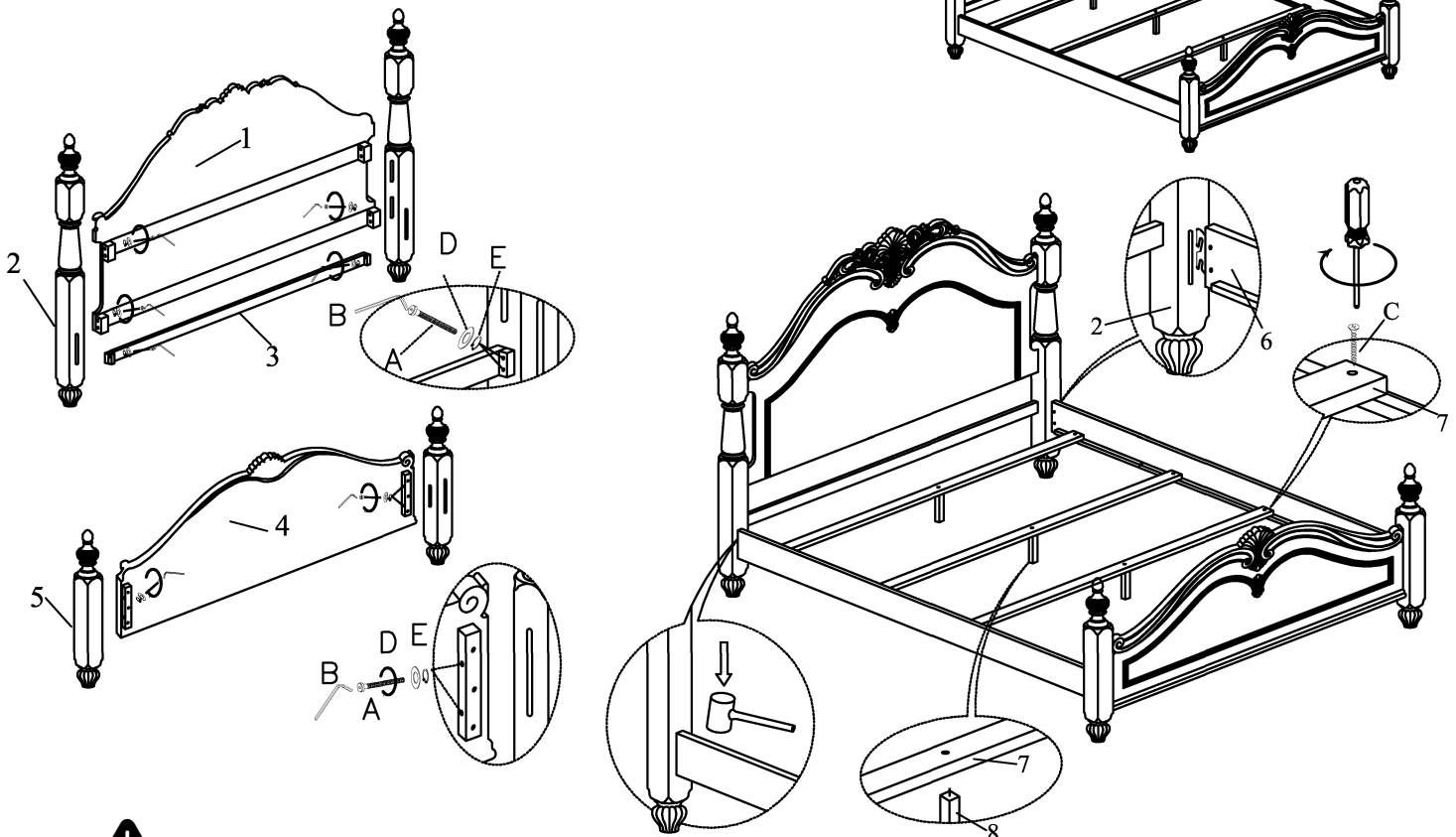

For items use on wooden floor, hard surfaces or carpets, it is recommended to install protective pads under all legs and supports to avoid/prevent from damages/scratches and discoloration