

FOLDING DESK - WHITE/GRAY
BUREAU PLIANT, BLANC/GRIS
ESCRITORIO PLEGABLE, BLANCO/GRIS

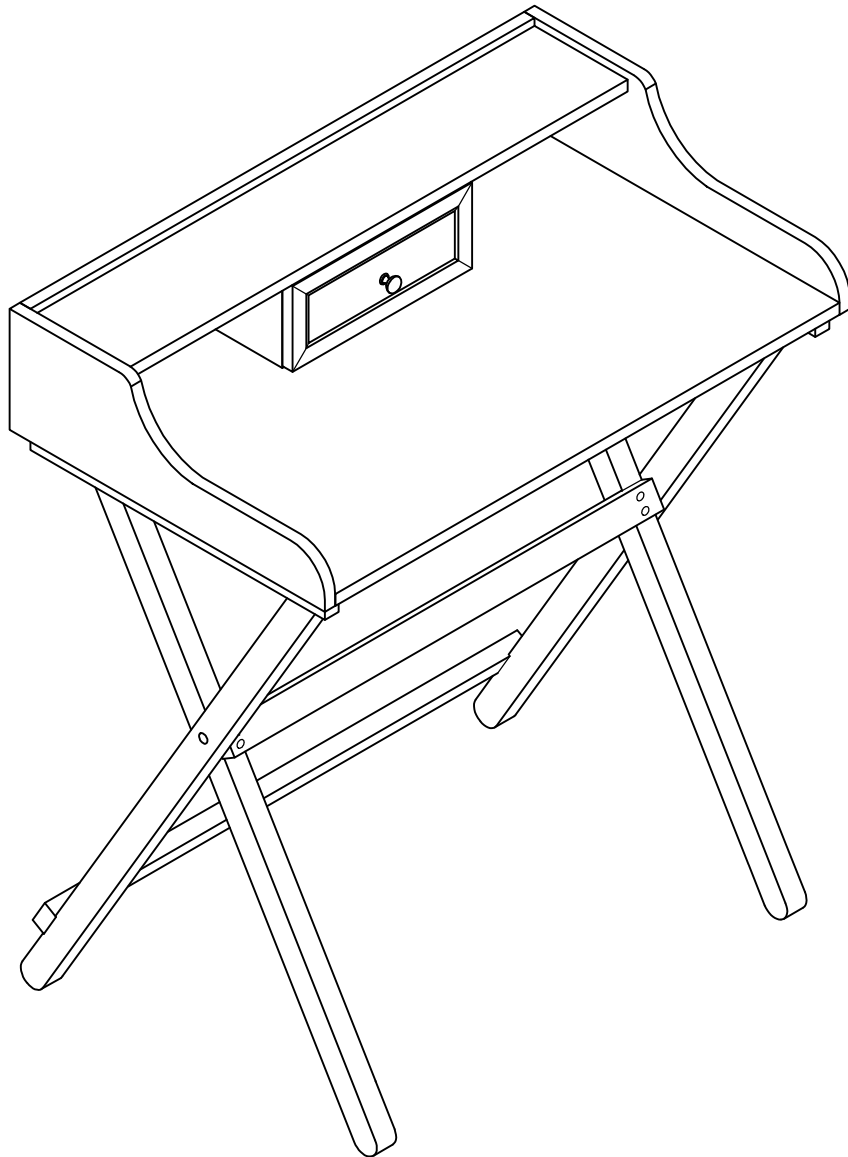

We are here to help!

Before you return it - contact us.

We do our best to insure that your furniture arrives in excellent condition. In the event that a part is damaged or missing, we will be happy to provide you with replacement parts, at no charge, within 30 days of purchase, providing the parts are available in our warehouse and the item purchased is part of our current inventory. In order to receive spare parts, at no charge, you must provide proof of purchase within 30 days.

If you need assistance with assembly or replacement parts, please call our Customer Service, prior to returning the item to the store.

Nous sommes là pour vous aider!

Avant de retourner le produit, veuillez communiquer avec nous.

Nous faisons tout en notre pouvoir pour que vous receviez votre meuble en parfait état. Toutefois, si une pièce est endommagée ou manquante, nous se fera un plaisir de vous envoyer gratuitement la pièce de rechange, dans les 30 jours suivant l'achat, à condition que nous ayons la pièce en stock et que le produit acheté fasse partie de notre inventaire courant. Afin de recevoir gratuitement la pièce de rechange, vous devez fournir une preuve d'achat dans un délai de 30 jours.

Si vous avez besoin d'une pièce de rechange ou d'aide pour l'assemblage, veuillez communiquer avec le Service à la clientèle de avant de retourner le produit au magasin.

¡Estamos aquí para ayudarle!

Antes de regresar el producto, comuníquese con nosotros.

Hacemos todo lo posible para que su mobiliario se le entregue en excelentes condiciones. En caso de que falte una pieza o esté dañada, nosotros le enviará con gusto la pieza de repuesto sin ningún costo dentro de los 30 días posteriores a la compra, siempre y cuando tengamos en existencia las piezas en nuestros almacenes y que el artículo comprado forme parte de nuestro inventario actual. Para recibir piezas de repuesto, sin costo adicional, debe enviarnos el comprobante de compra dentro de los 30 días después de la compra.

Si necesita ayuda para ensamblar su producto o para obtener piezas de repuesto, llame al Servicio al Cliente de antes de devolver el artículo a la tienda.

1. Take the drawer out.
Sortez le tiroir.
Saque el cajón.

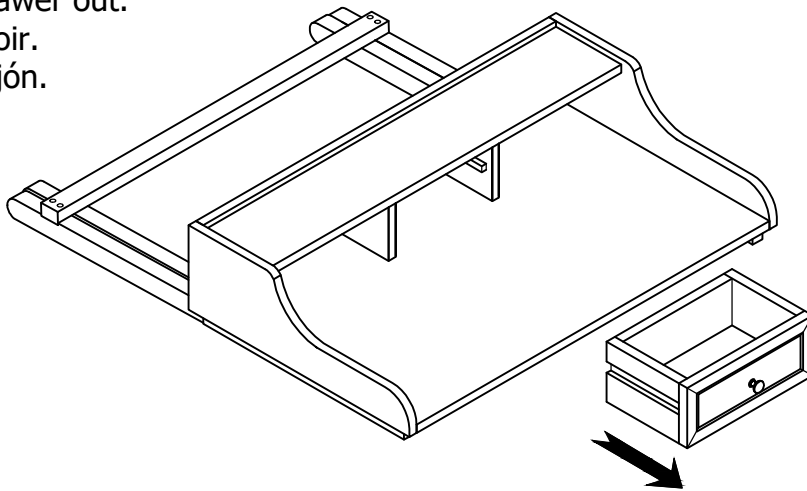

2. Turn over the desk.
Retournez le bureau.
Dé vuelta al escritorio.

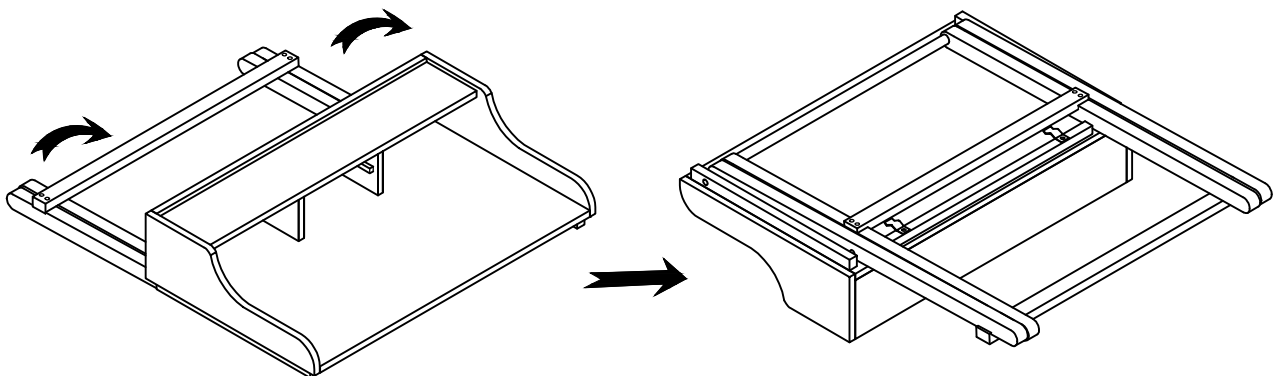

3. Lift up the leg frame.
Soulevez le châssis des pieds.
Levante el armazón de las patas.

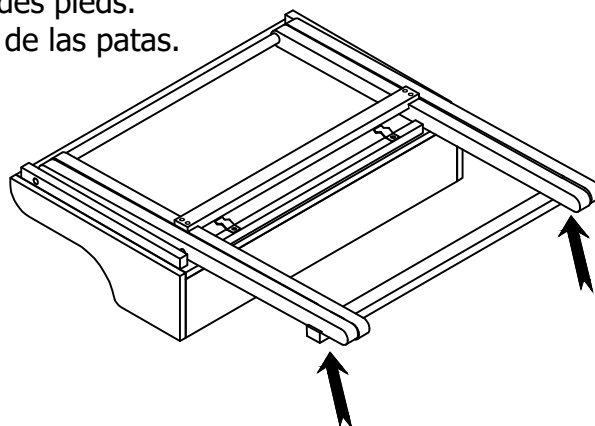

4. Hold the crossbar and pull back until the crossbar is held in place firmly under the metal stops.
Tenez la barre transversale et tirez jusqu'à ce que la barre transversale soit fermement maintenue sous les butées métalliques.
Sostenga la barra transversal y tire hacia atrás hasta que se mantenga firmemente en su lugar debajo de los topes metálicos.

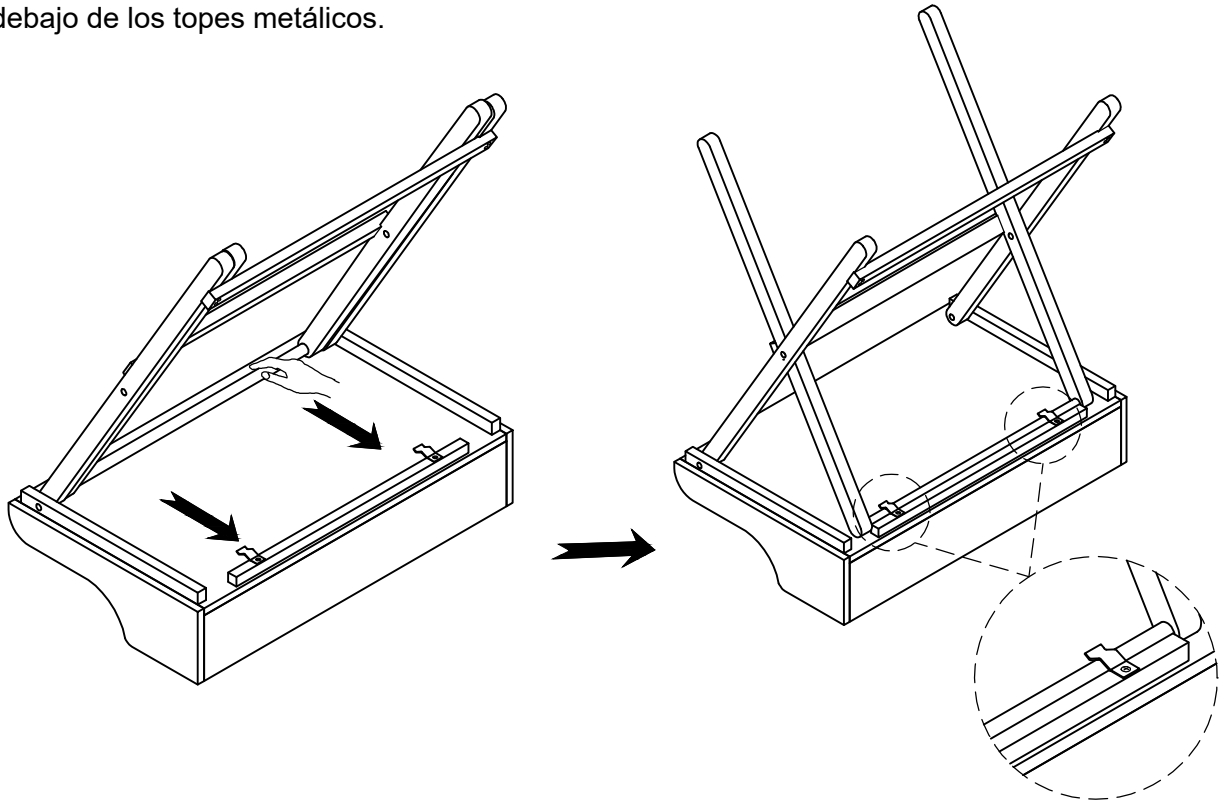



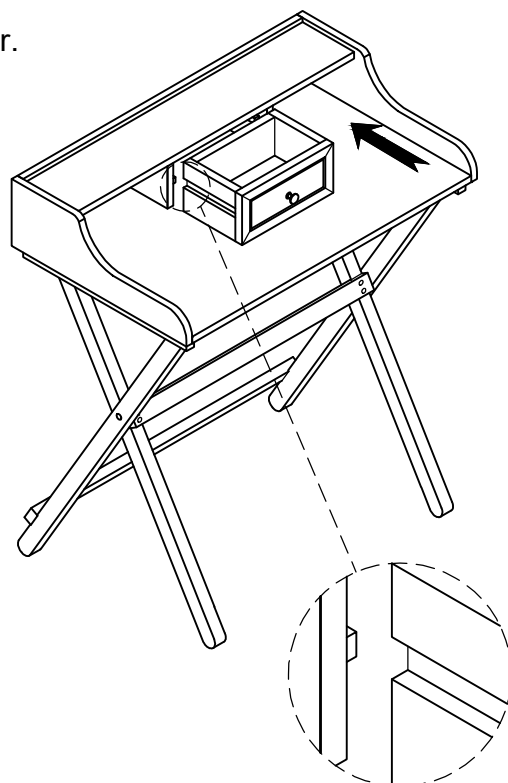

5. Put the drawer in.
Replacez le tiroir.
Ponga el cajón en su lugar.

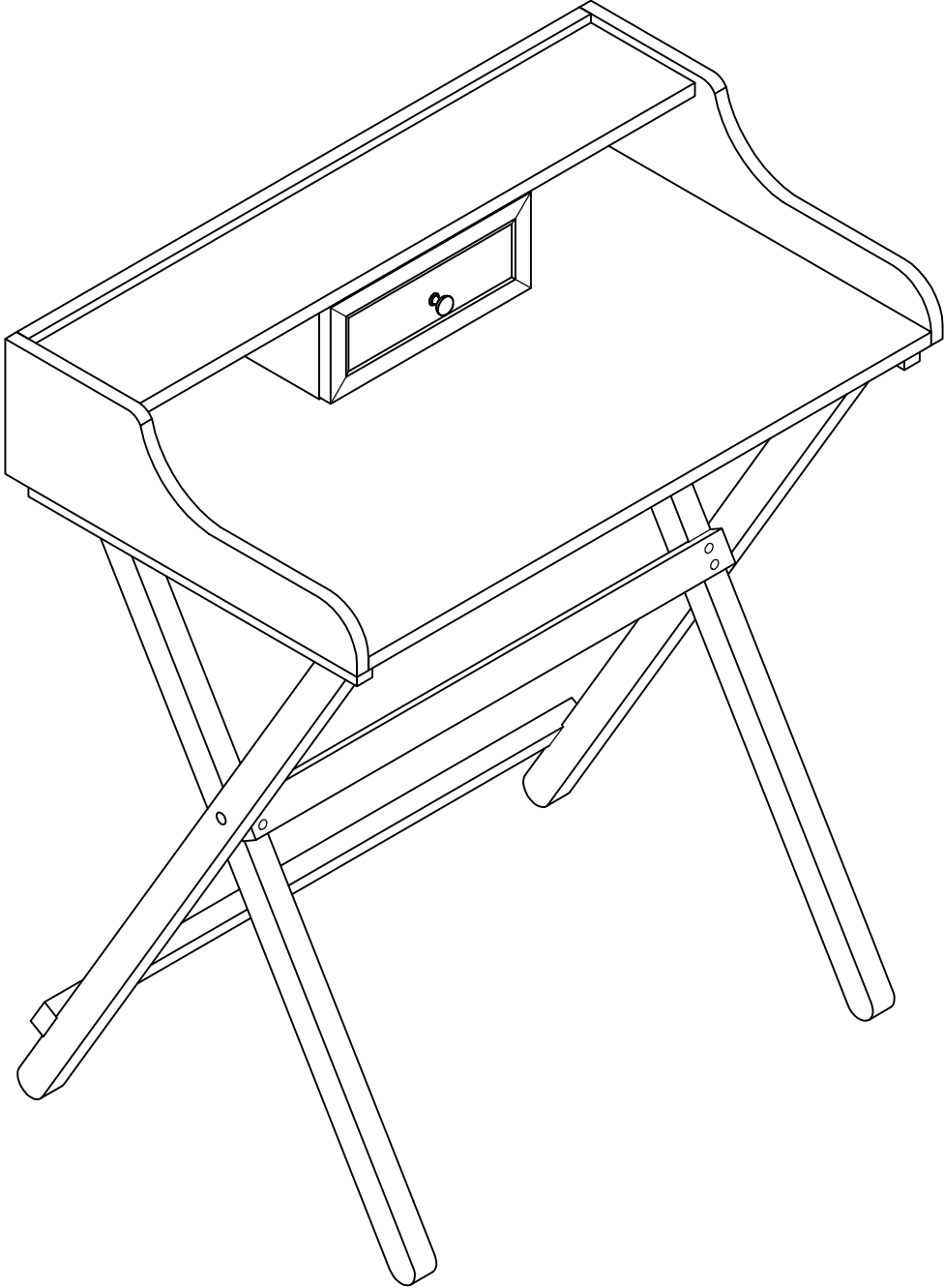

**COMPLETED ASSEMBLY
ASSEMBLAGE TERMINÉ
ENSAMBLAJE TERMINADO**

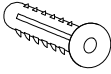
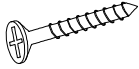

 Strap Courroies Abrazadera de sujeción A (1pc)	 Mounting Bracket Support de montage Ménsula de montaje B (2pcs)	 Wall Anchor Ancrages muraux Anclaje de pared C (2pcs)	 Short Screw Vis courte Tornillo corto D (2pcs)	 Long Screw Vis longue Tornillo largo E (2pcs)
--	---	---	--	---

PLEASE NOTE: For your safety, to prevent the danger of this unit tipping over, it is important that the wall anchors are properly attached.

S'IL VOUS PLAÎT NOTE: Pour votre sécurité, pour éviter le danger de cette unité de basculement, il est important que les chevilles sont correctement fixés.

NOTA: Para su seguridad, para evitar el peligro de esta unidad se vuelque, es importante que los anclajes de pared estén bien fijados.

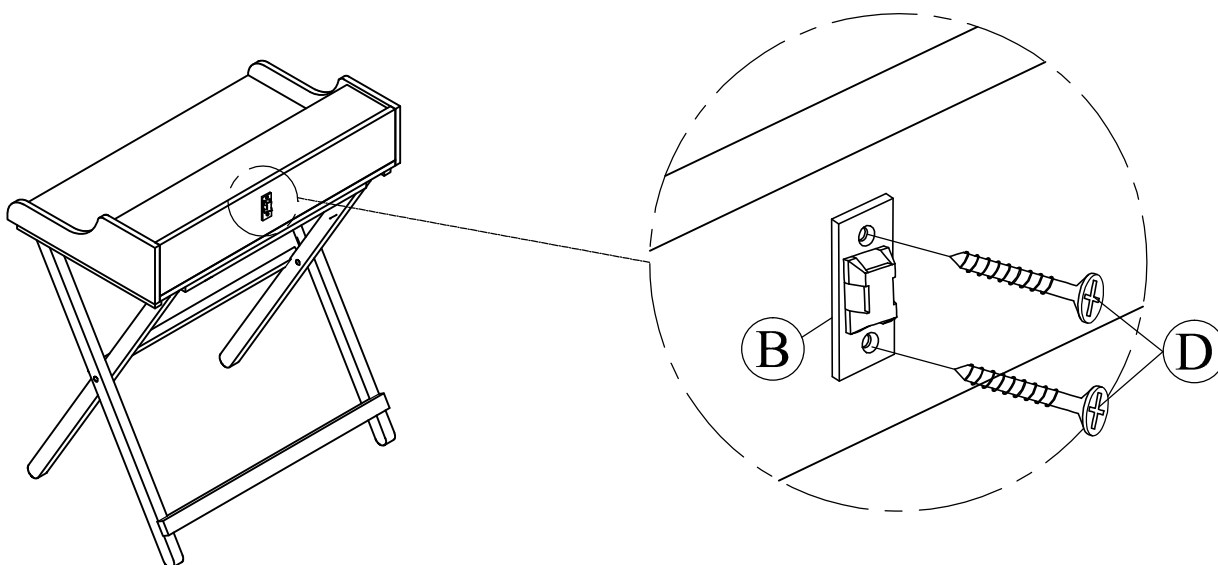
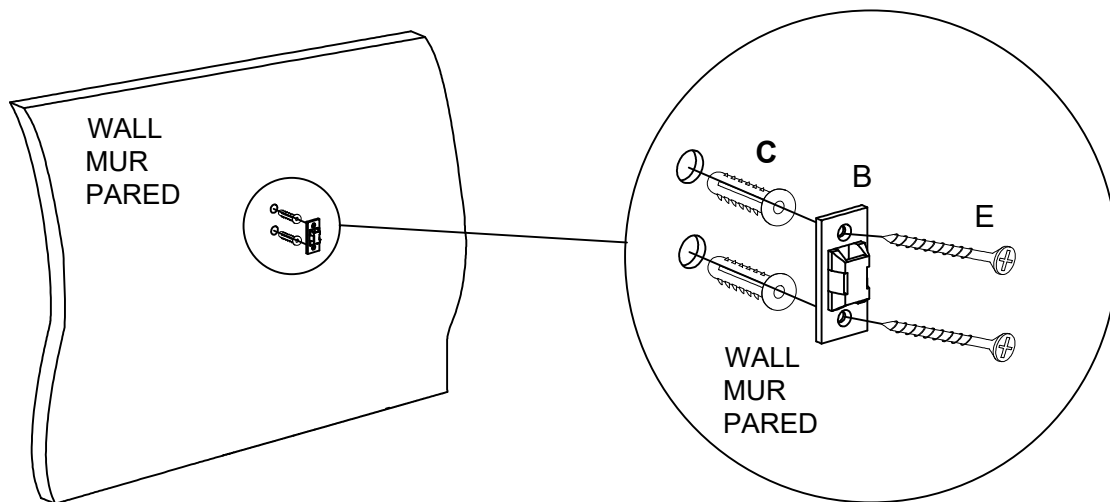

⚠ WARNING	⚠ AVERTISSEMENT	⚠ ADVERTENCIA
 <p>Serious or fatal crushing injuries can occur from furniture tip-over. To help prevent tip-over:</p> <ul style="list-style-type: none"> • Install tipover restraint provided. • Place heaviest items in the lowest drawers. • Do not set TV's or other heavy objects on top of this product, unless the product is specifically designed to accommodate them. • Never allow children to climb or hang on drawers, doors, or shelves. • Never open more than one drawer at a time. (OR) • Do not defeat or remove the drawer interlock system. <p>Use of tip-over restrains may only reduce, but not eliminate, the risk of tip-over.</p> <p><i>This is a permanent label. Do not remove!</i></p>	 <p>Le basculement du meuble peut causer de graves blessures par écrasement, voire la mort. Pour empêcher le basculement:</p> <ul style="list-style-type: none"> • Installer les dispositifs antibasculement fournis. • Ranger les articles les plus lourds dans les tiroirs du bas. • À moins qu'il ne soit conçu à cette fin, éviter de placer un téléviseur ou un objet lourd sur le dessus de ce meuble. • Ne jamais permettre à des enfants de monter sur les tiroirs, portes ou tablettes, ni de s'y suspendre. • Ne jamais ouvrir plus d'un tiroir à la fois. (OU) • Ne pas altérer ni retirer le système de verrouillage du tiroir. <p>L'utilisation d'un dispositif antibasculement ne peut que diminuer, et non éliminer, le risque de basculement.</p> <p><i>Cette étiquette est permanente. Ne pas tenter de l'enlever.</i></p>	 <p>El vuelco del mueble puede causar lesiones por aplastamiento e incluso la muerte. Para evitar que el mueble se vuelque:</p> <ul style="list-style-type: none"> • Instale los dispositivos antivuelco proporcionados. • Guarde los artículos más pesados en los cajones inferiores. • Evite colocar un televisor o un objeto pesado encima del mueble, salvo si éste último ha sido diseñado específicamente para dicho fin. • No permita que los niños suban sobre los cajones, las puertas o los estantes ni que se cuelguen de dichas piezas. • No abra más de un cajón a la vez. (O) • No altere ni quite el sistema de cerradura del cajón. <p>El uso de un dispositivo antivuelco sólo disminuye el riesgo de vuelco, no lo elimina.</p> <p><i>Esta etiqueta es permanente. No trate de quitarla.</i></p>

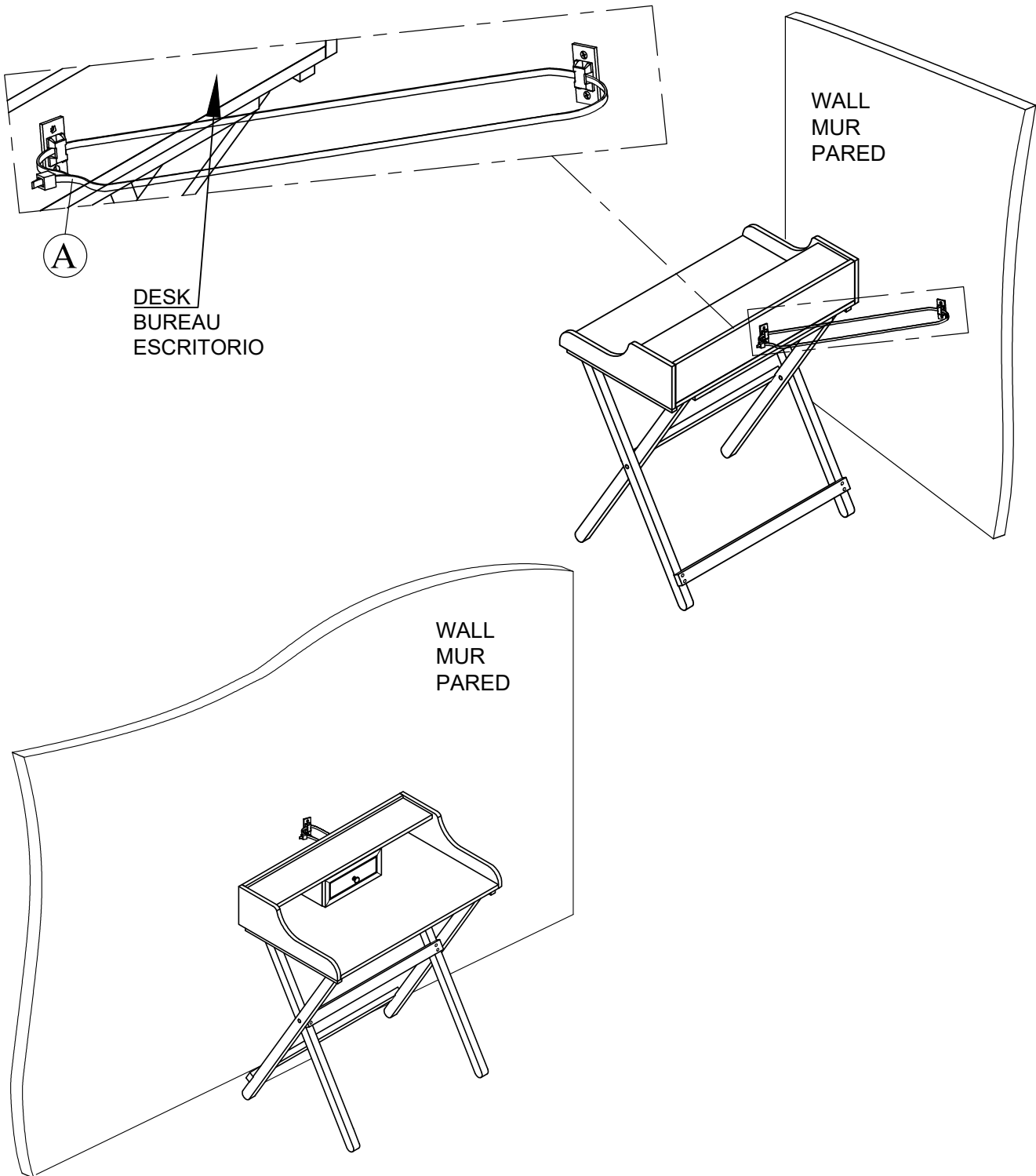

LIMITED 6 MONTHS WARRANTY
GARANTIE LIMITÉE DE 6 MOIS
GARANTÍA LIMITADA DE 6 MESES

WHAT IS COVERED

This product is covered under our manufacturer's 6 months limited warranty . To ensure your complete satisfaction, this warrants to the original purchaser that this supplied item is free from defects in material and workmanship, as of the date of purchase, and that it will under normal use and proper care, remain so for six months after the date of purchase.

Replacement of missing or initially defective parts will be sent, at no charge, for a period of 30 days from the date of purchase with valid proof of purchase providing the parts are available in our warehouse and the item purchased is part of our current inventory.

WHAT IS NOT COVERED

It remains the customer's responsibility for freight and packaging charges to and from the customer service center. Labor and material charges to remove or replace parts under this warranty are not covered. This warranty does not cover: Furniture used for commercial purposes, failures caused by improper installation assembly or by improper care, unreasonable or abusive use, freeze care, unreasonable or abusive use, freeze damage, acts of God, rust, purchased parts or return freight and packaging charges. Proof of purchase (dated register receipt) is required for this warranty claims.

HOW TO OBTAIN SERVICE

For further information, please contact our customer service department.

MADE IN VIETNAM
FABRIQUÉ AU VIETNAM
HECHO EN VIETNAM