



42 GREENE STREET LL NEW YORK NY 10013
T 212.355.0625 F 212.355.0628 WWW.OASIQ.US



YLAND Club Chair

W 43 1/4" D 31 7/16" H 27 1/8"

SH 11" CH 4 1/2" OSH 15 1/2"

38.5 lbs

Powder coated aluminum & rope

YLAND: FRAME



White



Anthracite

YLAND: CUSHION FABRICS



Canvas Natural



Lantern Slate

YLAND: ROPE



Taupe



White

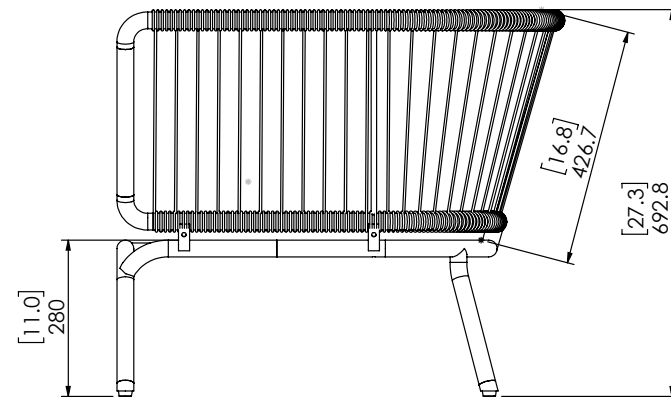
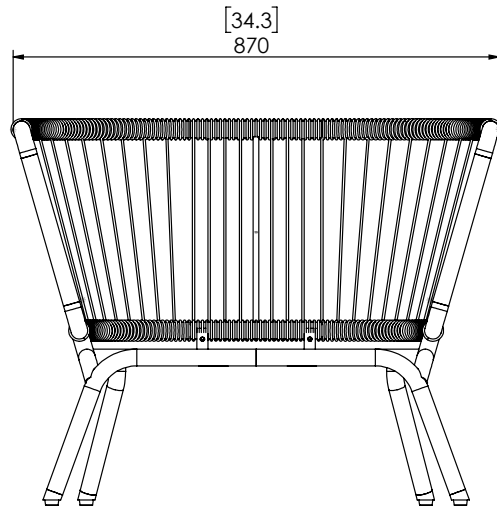
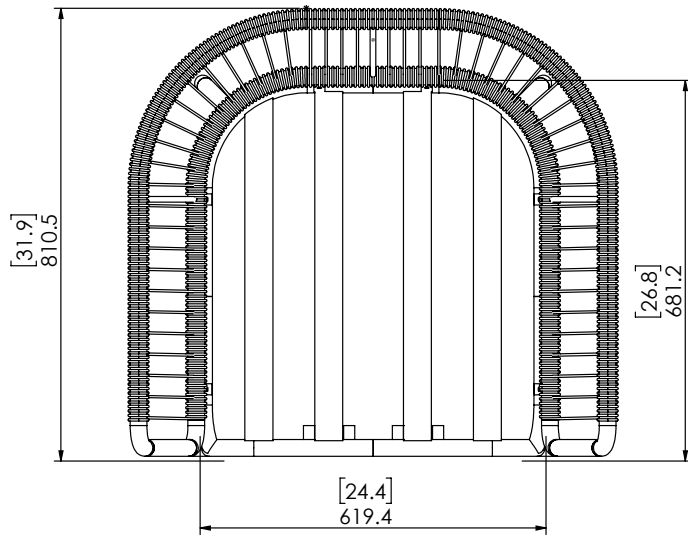

OASIQ

DWG.NO: FAEOA5-5

DIM EXT: 807X870X692.8mm

MATERIAL: AL

FINISH DATE: 2019-6-12
DRAWN BY: Mr. ADA

SCALE : 1:1

P. 2