

Owner Manual

PART LIST

CODE	QTY														
A	1														
B	1														
C	1														
D	1 <tr><td>E</td><td>3</td></tr> <tr><td>F</td><td>3</td></tr> <tr><td>G</td><td>3</td></tr> <tr><td>H</td><td>1</td></tr> <tr><td>I</td><td>1</td></tr> <tr><td>J</td><td>1</td></tr> <tr><td>K</td><td>1</td></tr>	E	3	F	3	G	3	H	1	I	1	J	1	K	1
E	3														
F	3														
G	3														
H	1														
I	1														
J	1														
K	1														

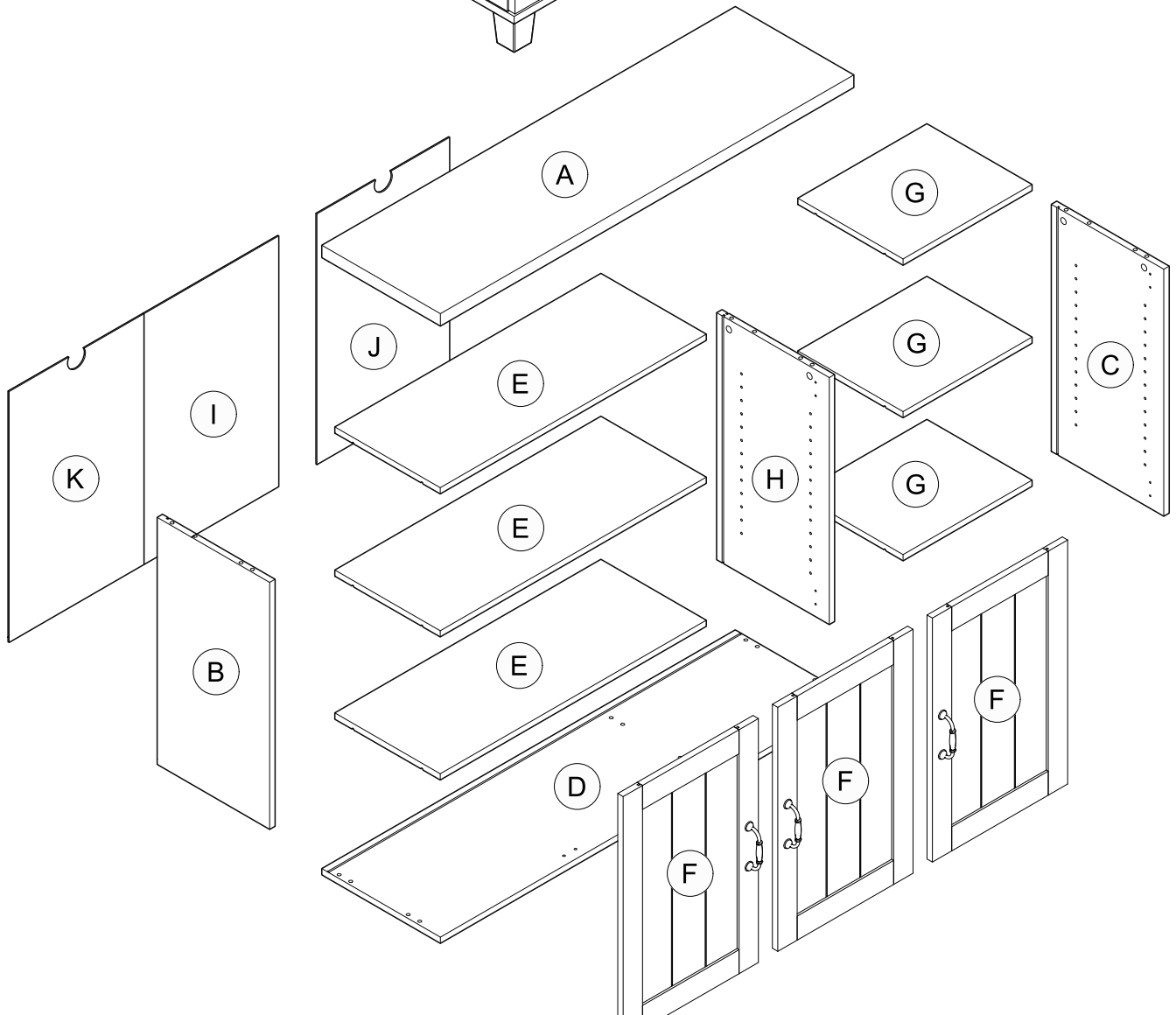
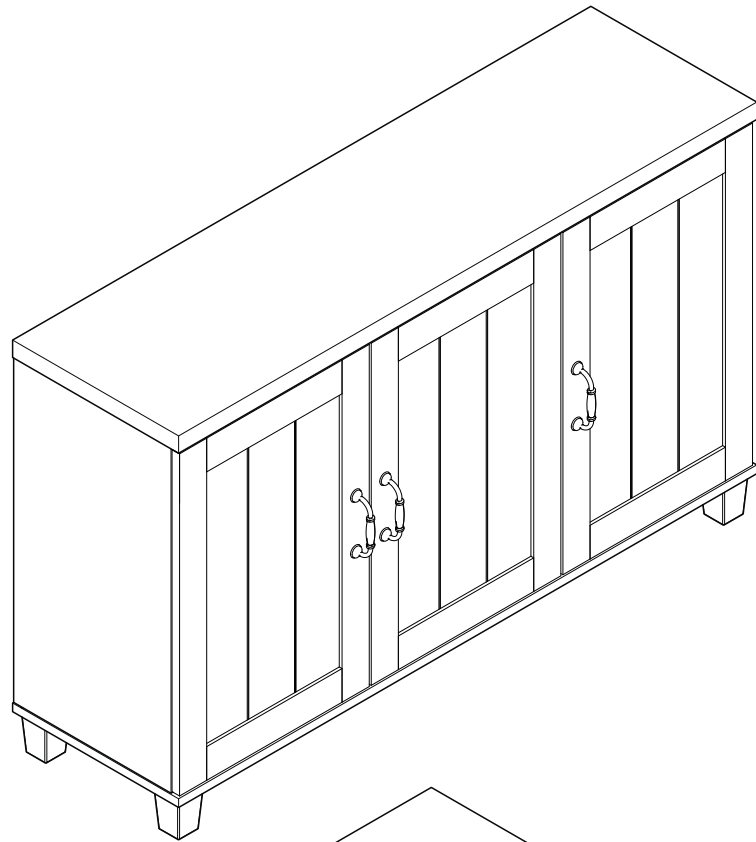

NOTES ON ASSEMBLY / NOTES POUR L'ASSEMBLAGE / NOTAS SOBRE EL ENSAMBLE

- To ensure ease of assembly read all instructions before assembly and follow step by step illustrations.
- Keep instructions for future use.
- Adult assembly required. ⚠
- Due to the presence of small parts during assembly, keep out of reach of children until assembly is complete.

- Pour assurer l'assemblage facile veuillez lire toutes les instructions avant l'assemblage et veuillez suivre les illustrations pour chaque etapes.
- Veuillez garder ces instructions pour l'usage ulterieur.
- Assemblage requis pas un adulte. ⚠
- Due a la presence de petite pieces durant l'assemblage, veuillez garder hors de porter des enfants jusqu'a ce que l'assemblage soit completer.

- Para garantizar la facilidad de ensamble lea las instrucciones antes de iniciar y siga paso a paso las ilustraciones.
- Guarde las instrucciones para futuras referencias.
- El ensamble requiere de un adulto. ⚠
- Debido a que hay piezas pequeñas, mantenga fuera del alcance a los niños durante el ensamble, hasta que haya terminado.

MAINTENANCE TIPS / CONSEILS D'ENTRETIEN / CONSEJOS DE MANUTENIMIENTO

- Never let liquids or damp cloths sit on this furniture.
- Never use chemical cleaning products. They can damage the finish. For cleaning, use only a slightly damp cloth and wipe dry.
- To avoid dulling of the finish, do not place furniture in direct sunlight.
- Do not put plastic or rubber rings under appliances. Use cloth of felt protectors.
- To clean, use a soft or slightly damp cloth, then wipe with a clean, dry cloth.

- Ne jamais laisser de liquide ou linge humide sur le meuble.
- Ne jamais utiliser de nettoyeurs à base de produits chimiques, cela va endommager le fini. Utiliser seulement un linge légèrement humide.
- Ne pas placer le meuble directement au soleil pour prévenir le ternissement.
- Évitez de déposer des appareils avec des rondelles de plastique ou de caoutchouc. Utilisez un protecteur en tissu ou en feutre.
- Pour nettoyer, utilisez un linge doux ou légèrement humecté. Essuyez par la suite avec un linge propre et sec.

- Nunca deje un líquido o un trapo húmedo sobre el mueble.
- Nunca utilice limpiadores a base de químicos, estos dañaran le acabado. Use sólo un paño húmedo.
- No exponga el mueble directamente al sol para prevenir empañamiento.
- Evite apoyar aparatos con redondeles de plástico o de goma. Utilizar un protector de tela o de fieltro.
- Para limpiar, utilice un trapo suave o ligeramente humedecido. Seque luego con un trapo limpio

WARNING **AVERTISSEMENT / ADVERTENCIA**

Serious or fatal crushing injuries can occur from furniture tip-over. To help prevent tip-over:

- It is important to place the safety bracket included.
- Place heaviest items in the lowest storage space.
- Never allow children to climb or hang on drawers, doors, or shelves.
- Never open more than one drawer at a time.
- If a heavy object is placed on top or inside the furniture, consider this risk.

Use of tip-over restraints reduce, but does not eliminate, the risk of tip-over.

Des blessures graves ou fatales peuvent résulter de basculement du meuble. Afin de prévenir le basculement :

- Il est important d'installer le crochet de sécurité inclus.
- Placer les items les plus lourds dans les espaces de rangement du bas.
- Ne jamais laisser un enfant grimper sur les tiroirs,
- les portes et les tablettes ou s'accrocher à ceux-ci.
- Ne jamais ouvrir plus d'un tiroir à la fois.
- Si un objet lourd est placé sur l'unité ou à l'intérieur, considérez le risque de basculement.





L'utilisation de dispositif antibasculement réduit les risques de basculement, sans les éliminer totalement.

El volcadura del mueble puede ser causa de lesiones graves o de un atropellamiento fatal. Para evitar la volcadura :



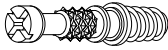

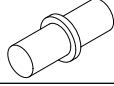
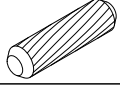
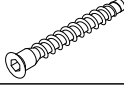
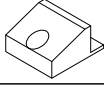
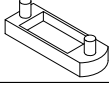
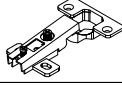
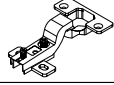

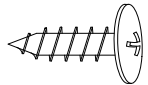
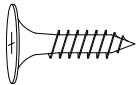
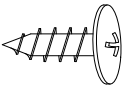
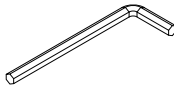
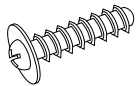
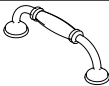
- Es importante instalar el gancho de seguridad.
- Ponga las cosas pesadas en los compartimentos más bajos.
- Nunca permita que un niño se suba o se cuelgue en cajones, puertas o estantes.
- Nunca abra más de un cajón a la vez.
- Si un objeto pesado esta colocado dentro o sobre el mueble, considere
- el riesgo de que se puede voltear.

El uso de sujetadores para evitar la volcadura sólo puede disminuir el riesgo de una volcadura, pero no lo elimina.

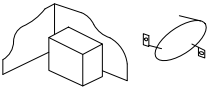
HARDWARE QUINCAILLERIE / HERRAJE

(1)	Minifix Bolt  6 pcs	(2)	Minifix Cam  6 pcs	(3)	Shelf Support  24 pcs
(4)	Wood Dowel $\phi 8 \times 30 \text{mm}$  12 pcs	(5)	Unitar Screw M6.3 x 50mm  6 pcs	(6)	192 Stub  15 pcs
(7)	Door Stopper  2 pcs	(8)	Hinges 5/8"  4 pcs	(9)	Hinges 1/4"  2 pcs
(10)	Octon Leg  5 pcs	(11)	Screw #8 x 25mm  10 pcs	(12)	Screw M3.1 x 20mm  15 pcs
(13)	Screw #10 x 16mm  24 pcs	(14)	Allen M4  1 pc	(15)	Handle Screw M4 x 19mm  6 pcs
(16)	Handle  3 pcs				

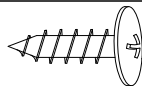

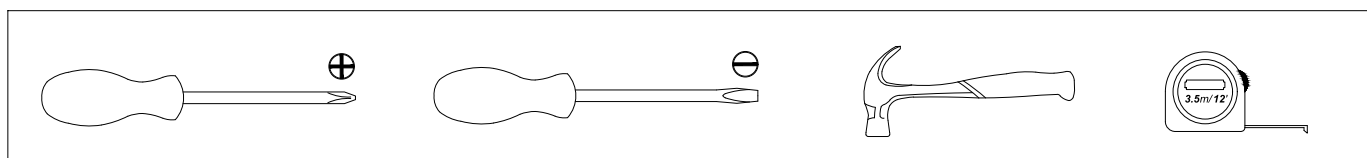

FURNITURE TIPPING RESTRAINT SEGURO CONTRA VOLCADO DE MUEBLES DISPOSITIF DE SÉCURITÉ POUR MEUBLES

 x 1 	(17)	Mounting L Bracket  2 units	(18)	Flat Washer M6 x 16mm  2 units
	(19)	Screw #10 x 16mm  2 units	(20)	Screw M4 x 38mm  2 units

TOOLS NOT INCLUDED OUTILS PAS INCLUS / HERRAMIENTAS NO INCLUIDAS

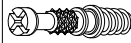

STEP 1

1		6 pcs
7		1 pc
17		2 pcs
18		2 pcs
19		2 pcs

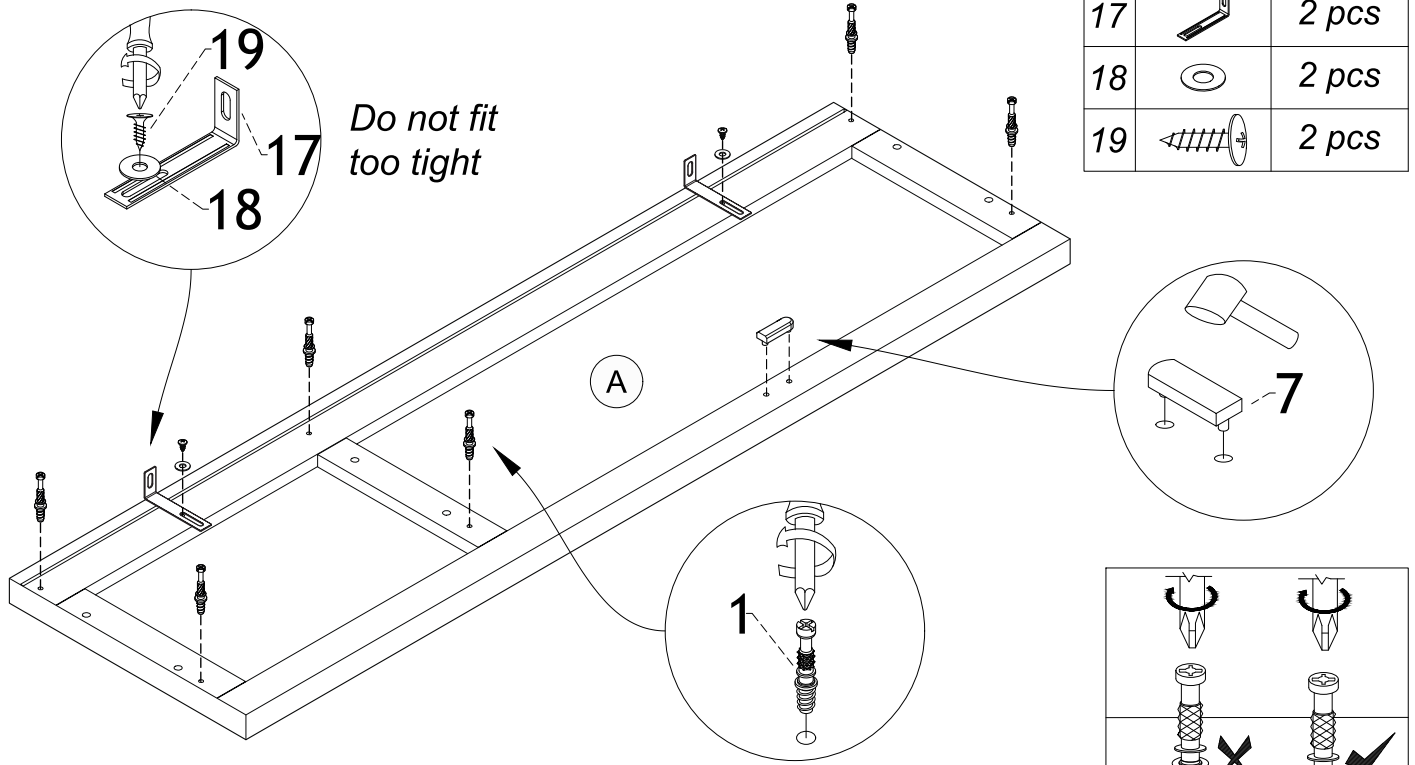

STEP 2

4		6 pcs
---	---	-------

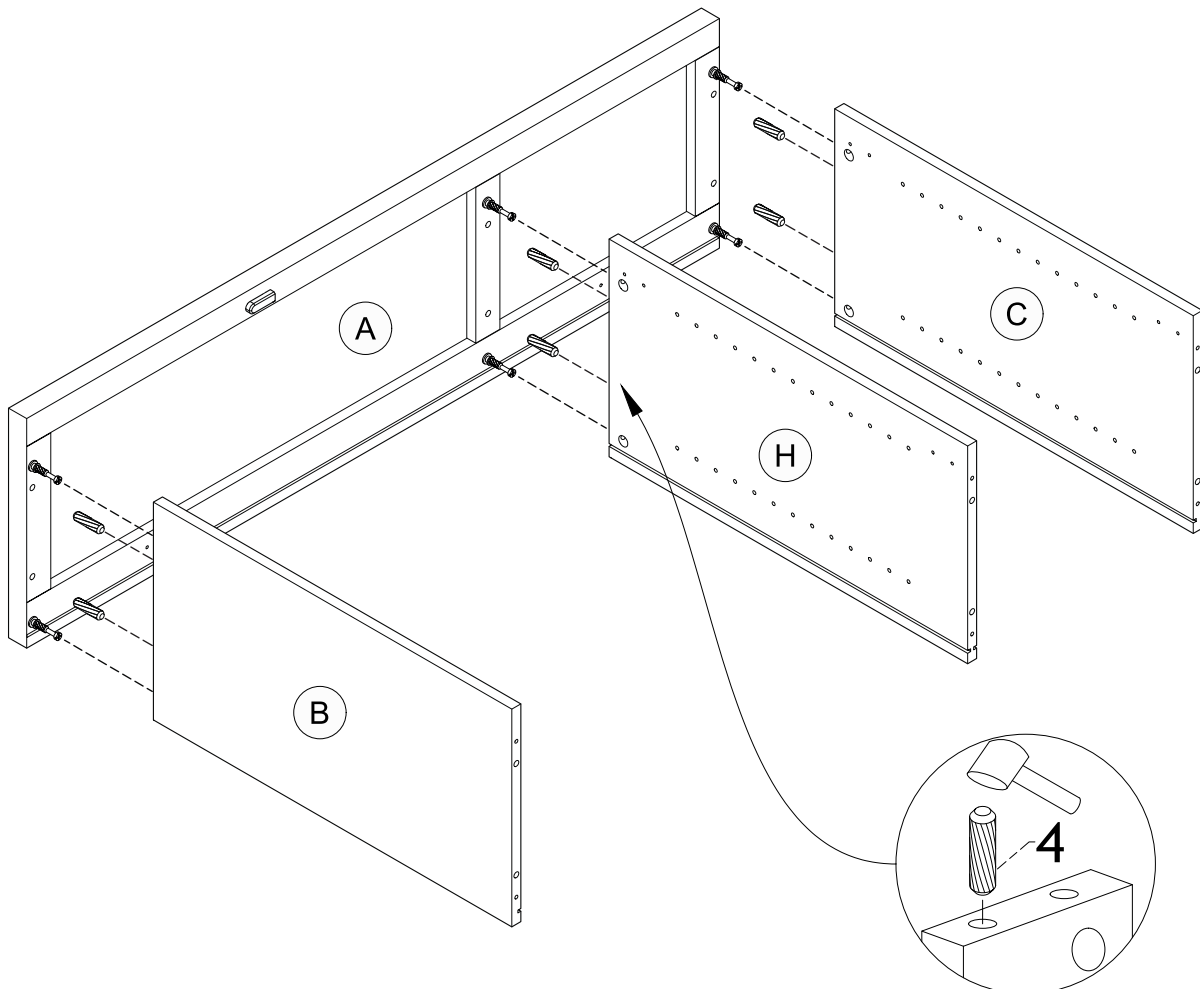



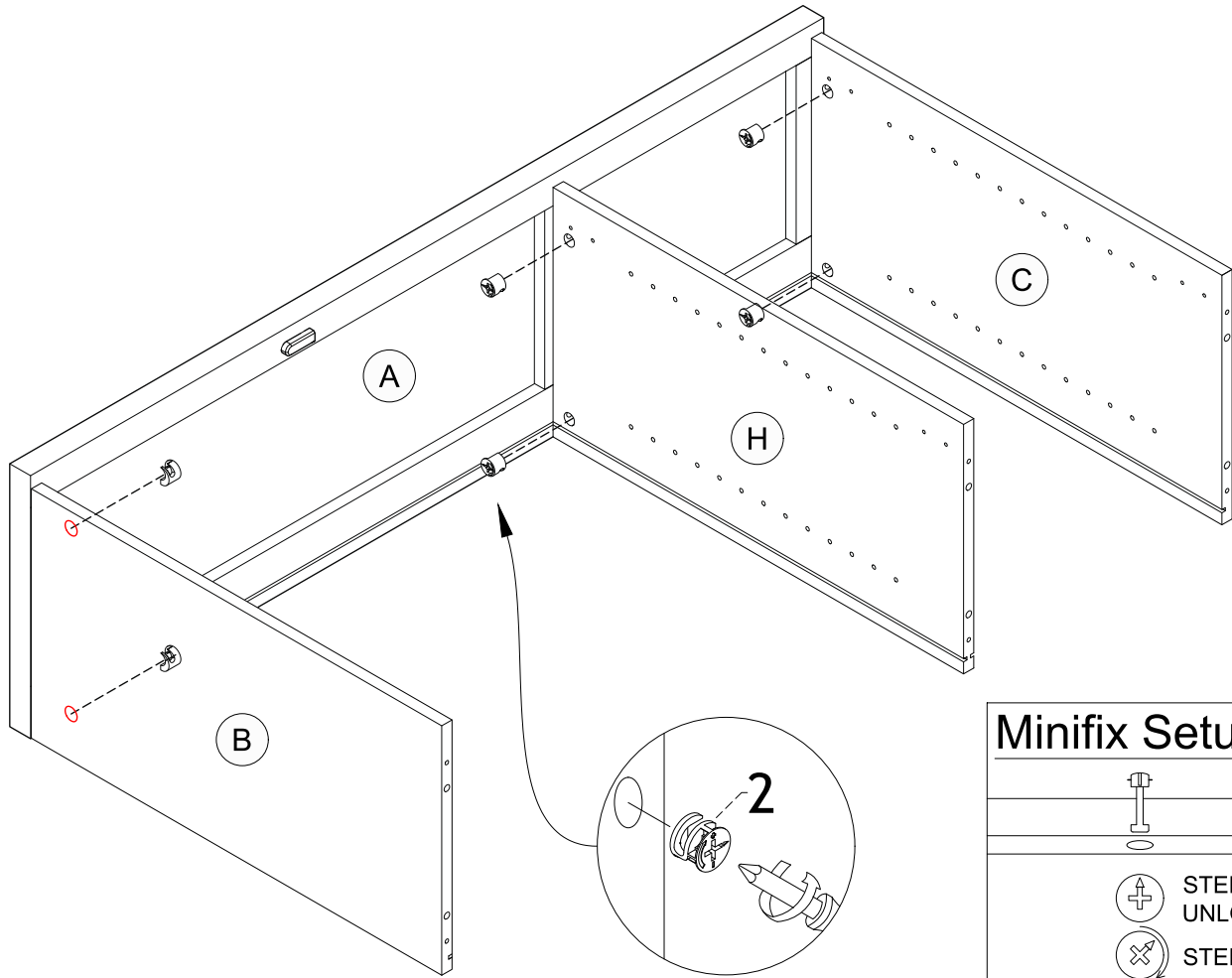

STEP 3

2		6 pcs
---	--	-------



Minifix Setup :

	
	STEP 1 UNLOCK
	STEP 2
	STEP 3 LOCK

STEP 4

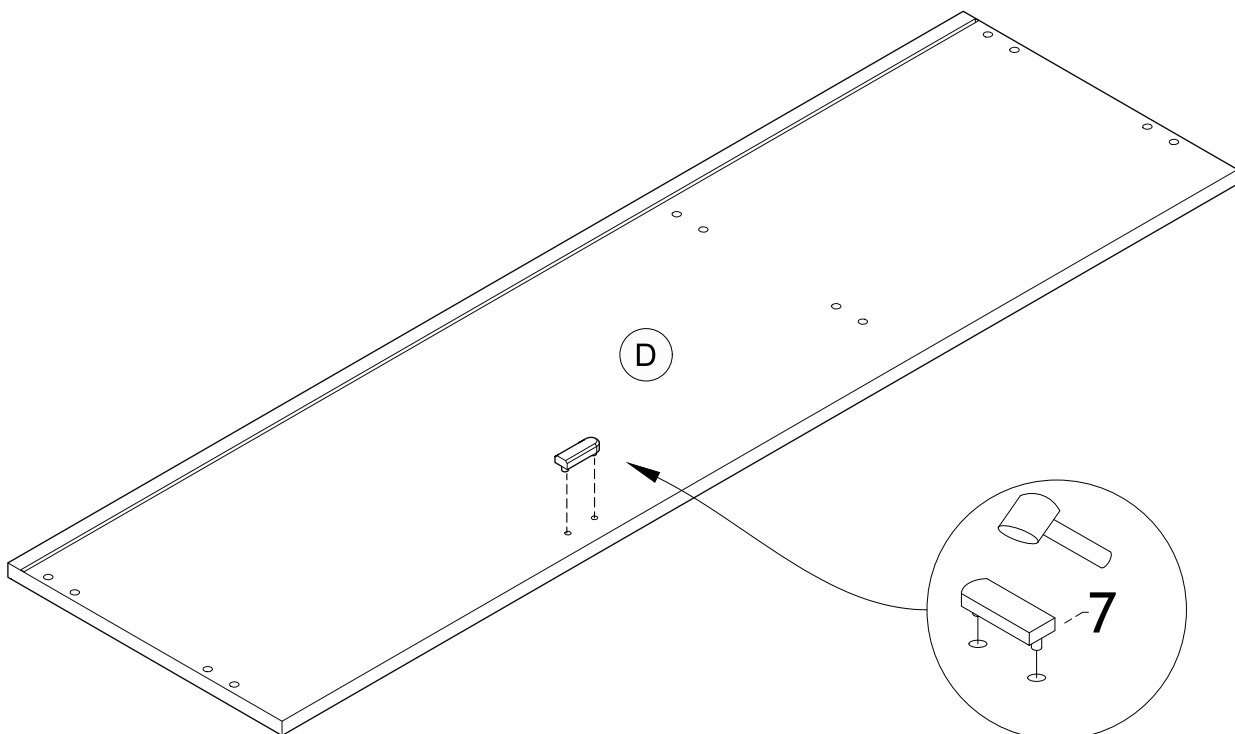

7		1 pc
---	---	------

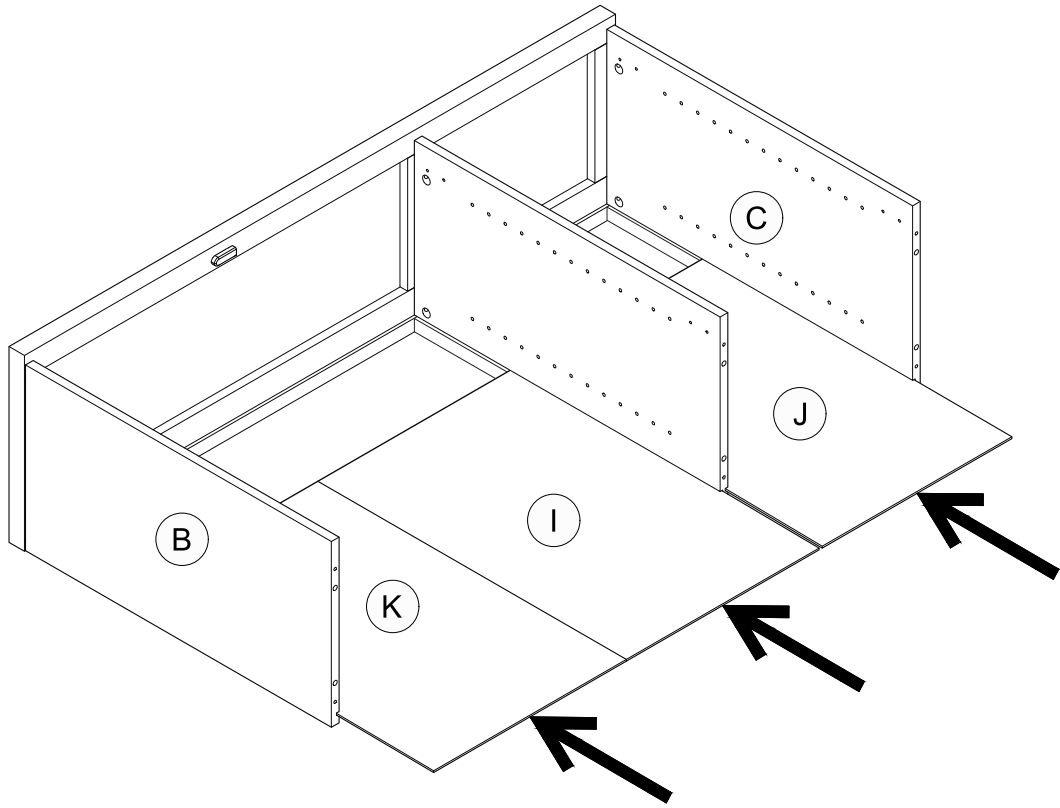

STEP 5



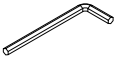

STEP 6

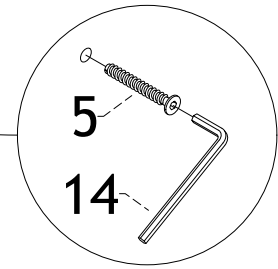
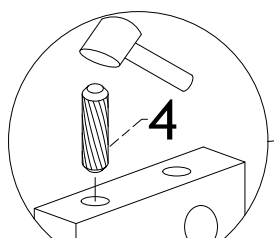
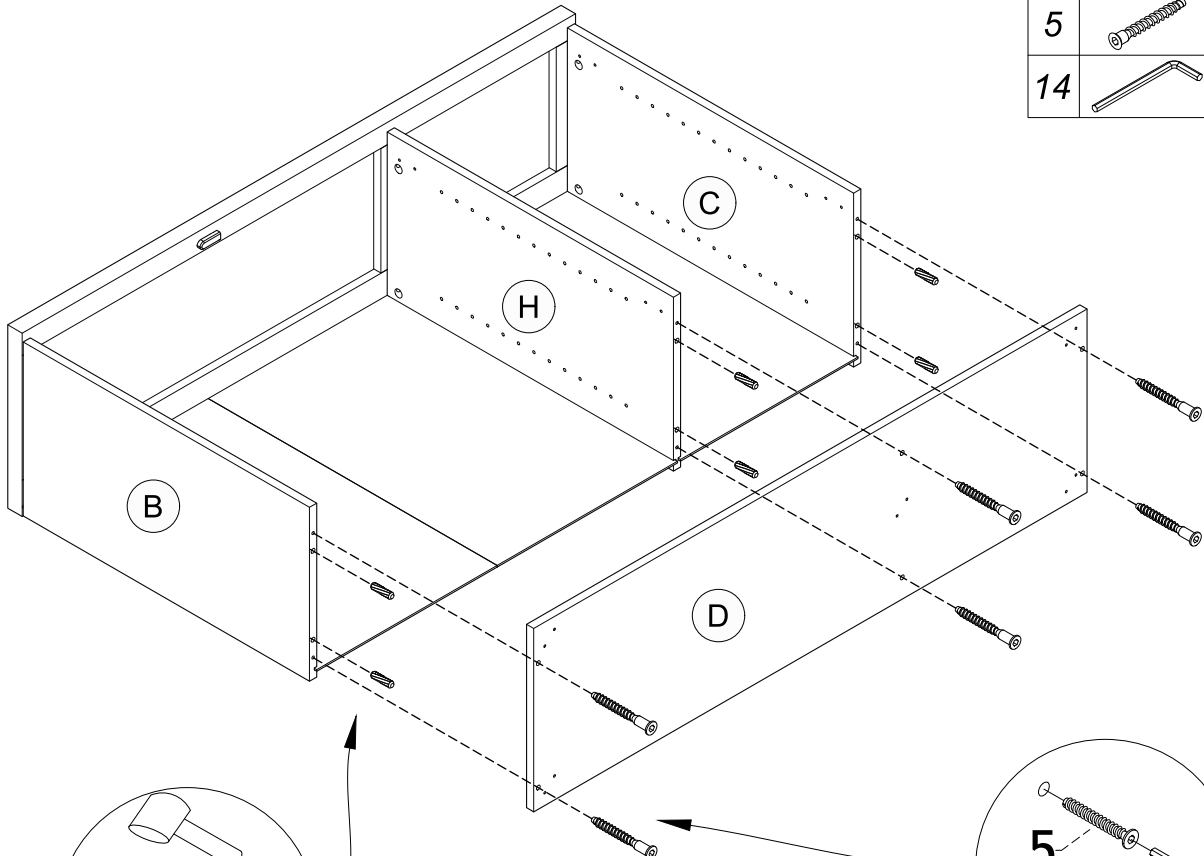
4		6 pcs
5		6 pcs
14		1 pc



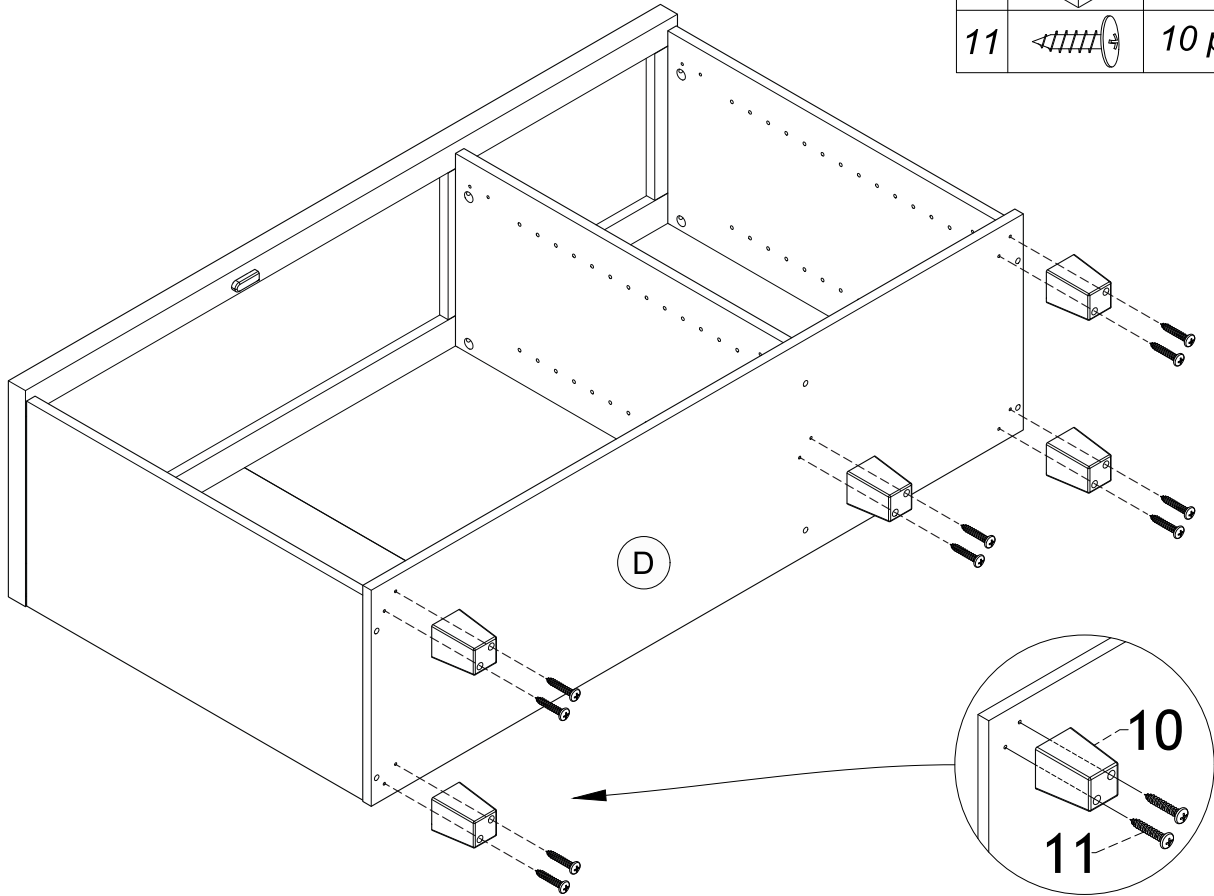

STEP 7

10		5 pcs
11		10 pcs



STEP 8

6		15 pcs
12		15 pcs

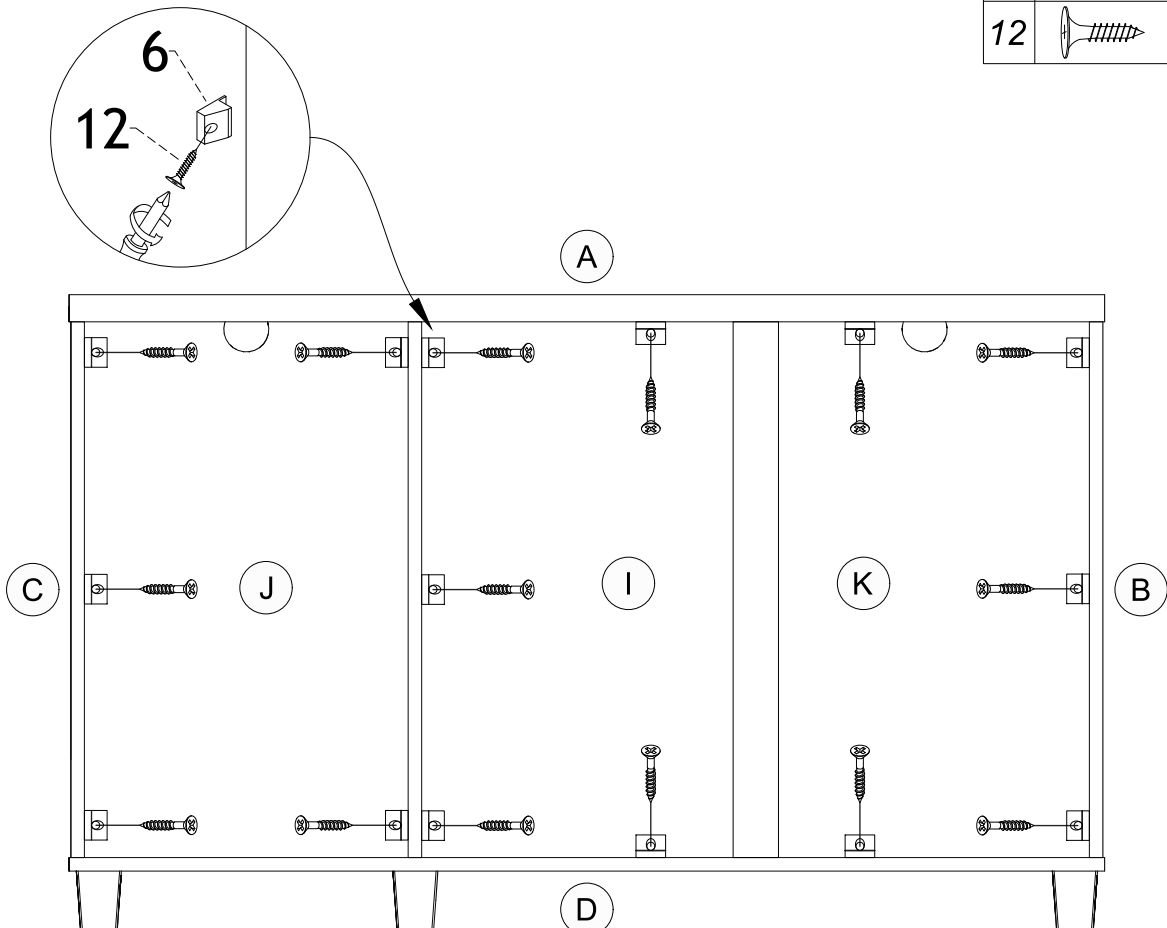

FURNITURE TIPPING RESTRAINT SEGURO CONTRAVOLCADO DE MUEBLES DISPOSITIF DÉ SÉCURITÉ POUR MEUBLES

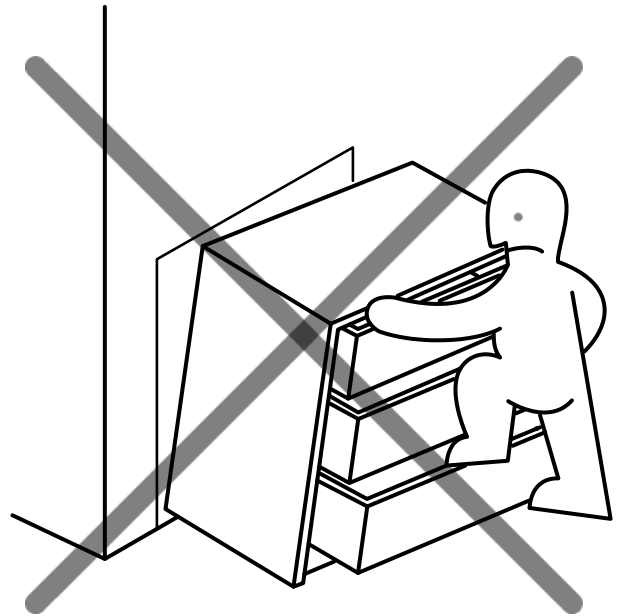
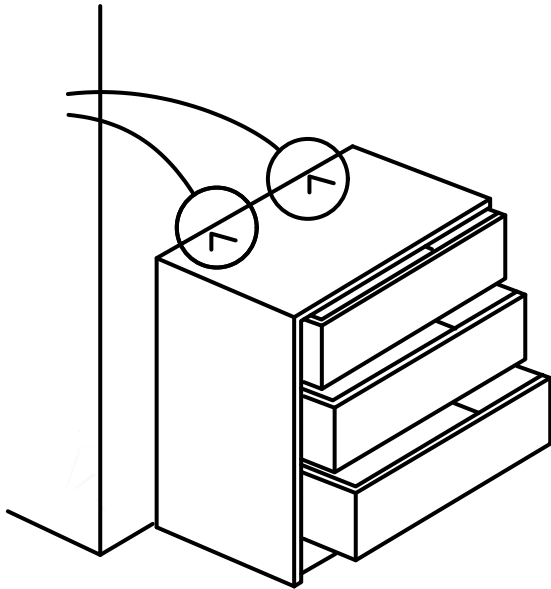

STEP 9

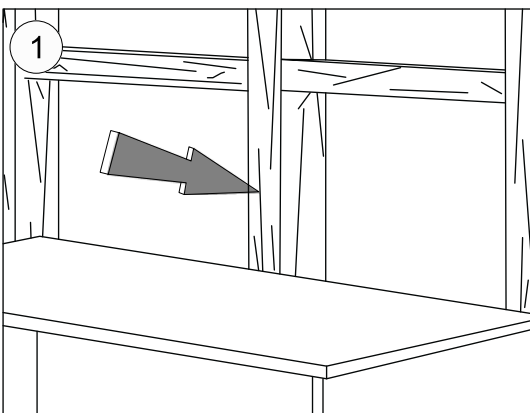

Locate a wall stud:

- Move the furniture unit to its final position to the wall
- Locate a wall stud behind the furniture unit

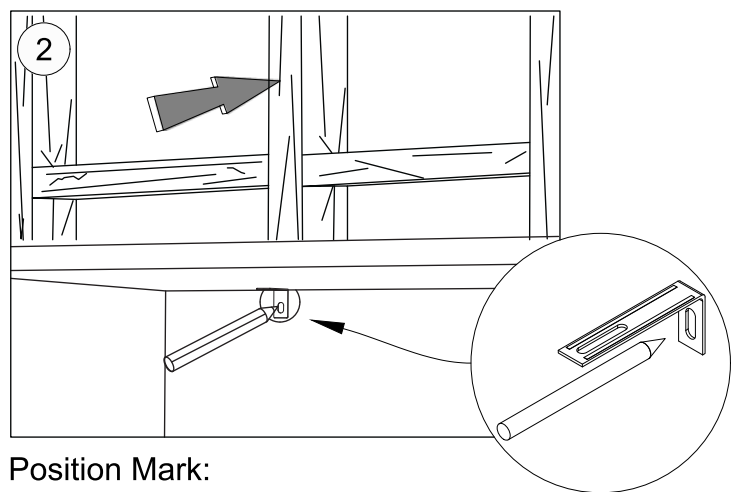

Position Mark:

- Adjust the safety bracket (17) to be flush to the wall
- Use the Pencil to mark the positioning hole on a wall stud

20  2 pcs

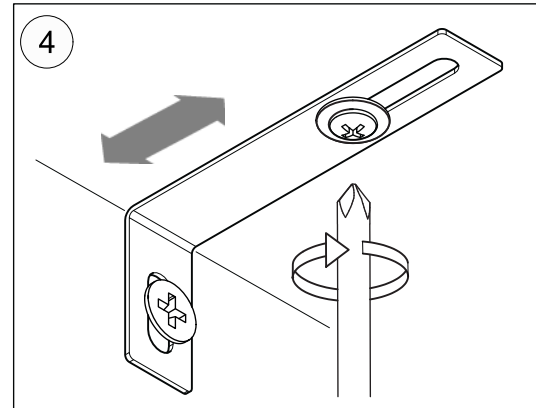
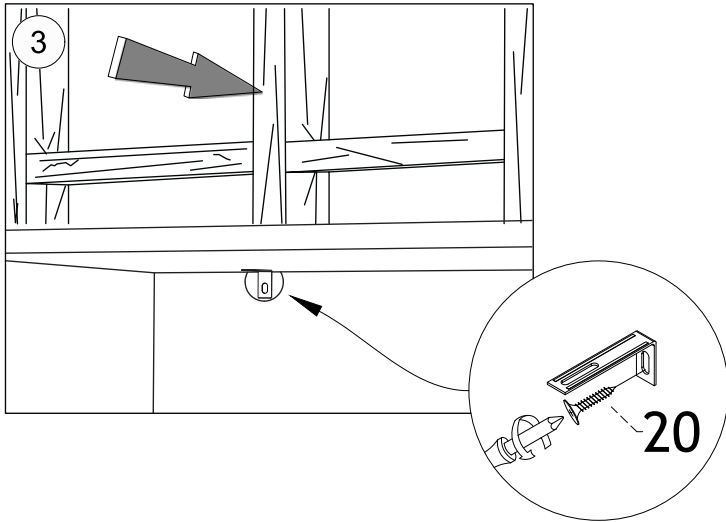

Screw the safety bracket to the wall stud:

- Screw the safety bracket (17) to the wall stud with Screw (20)

Adjust the furniture:

- Tighten back the screw (19) to secure the furniture to be locked to the wall

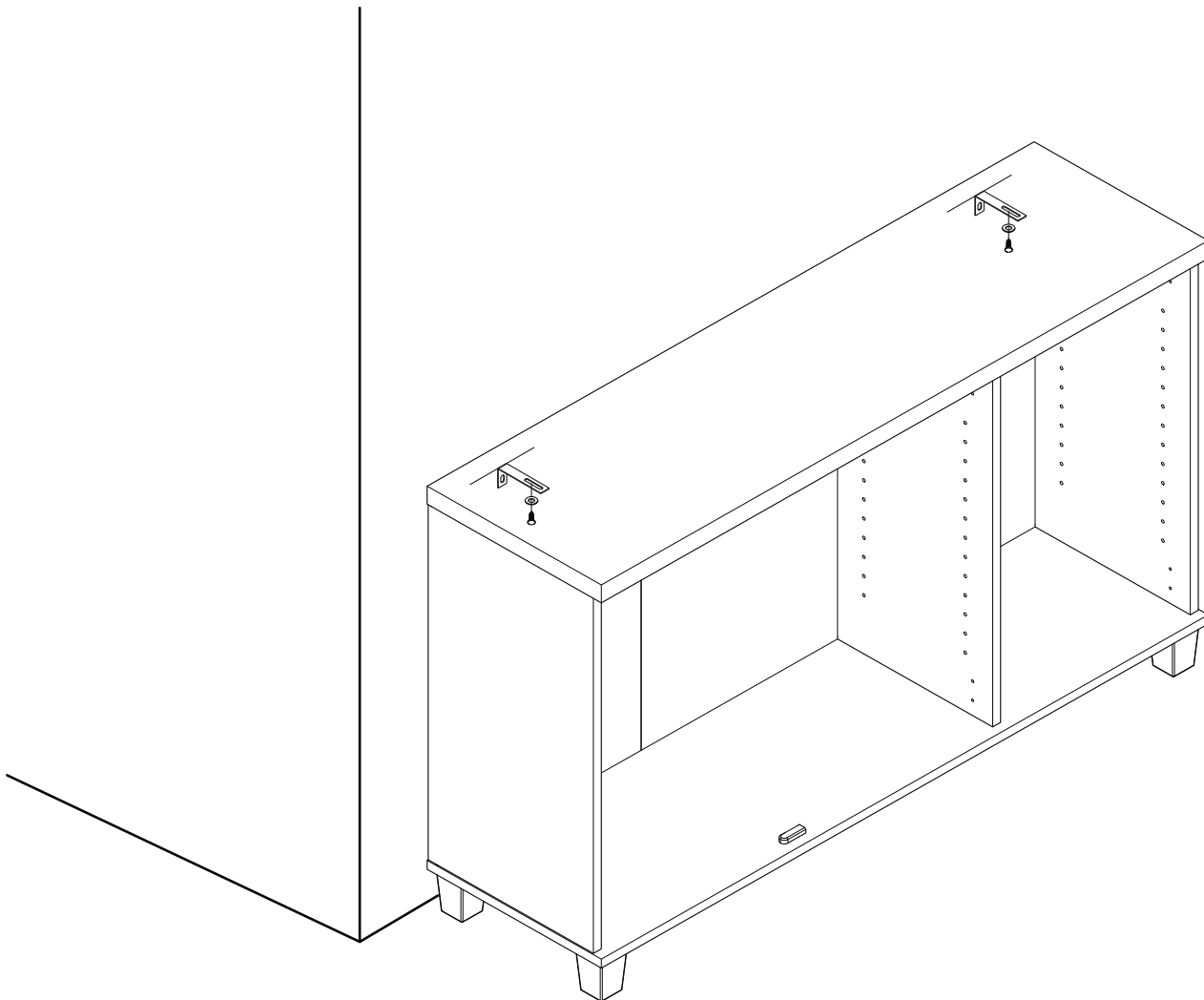

STEP 10

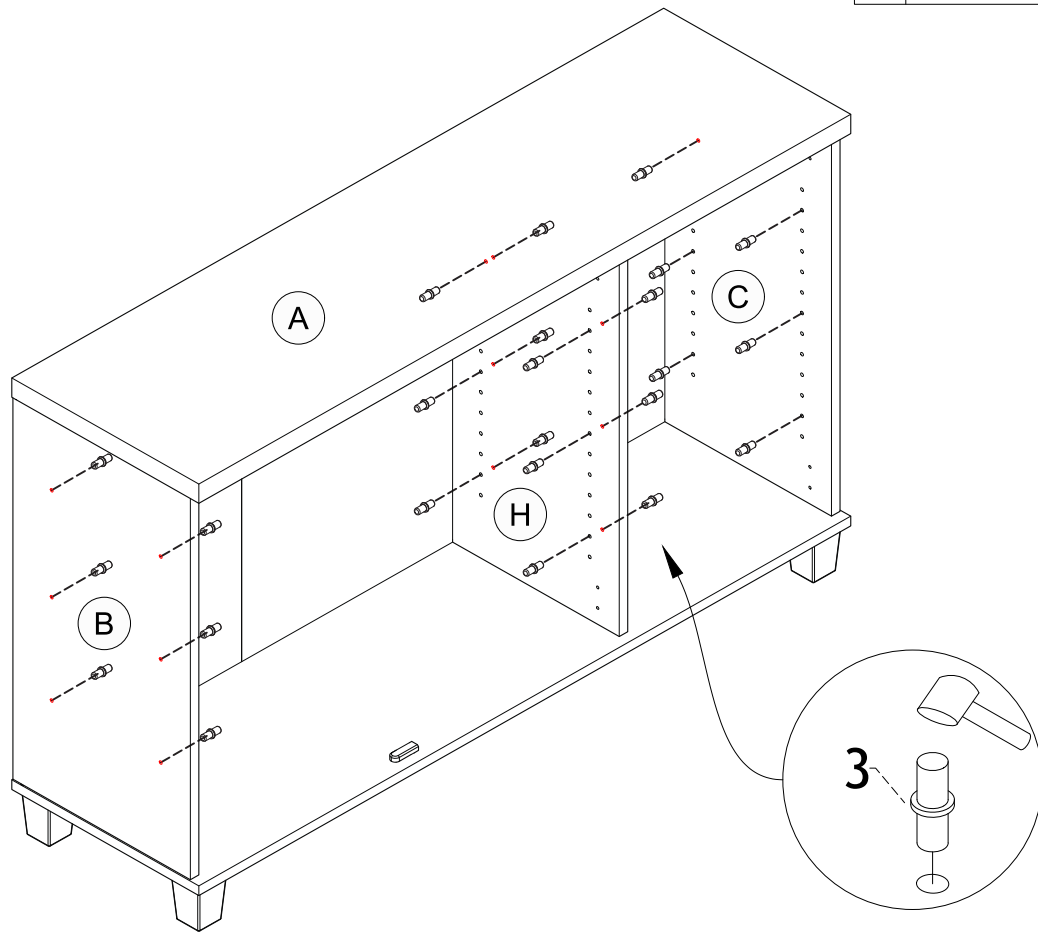

3		24 pcs
---	--	--------

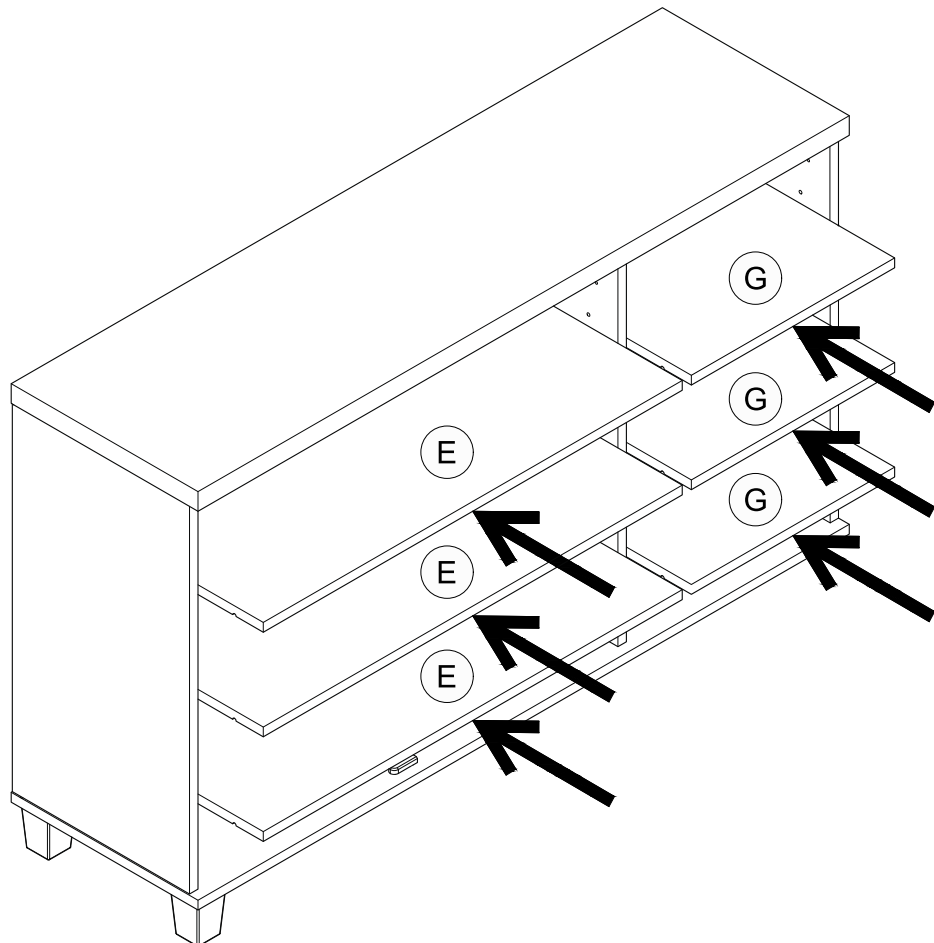

STEP 11



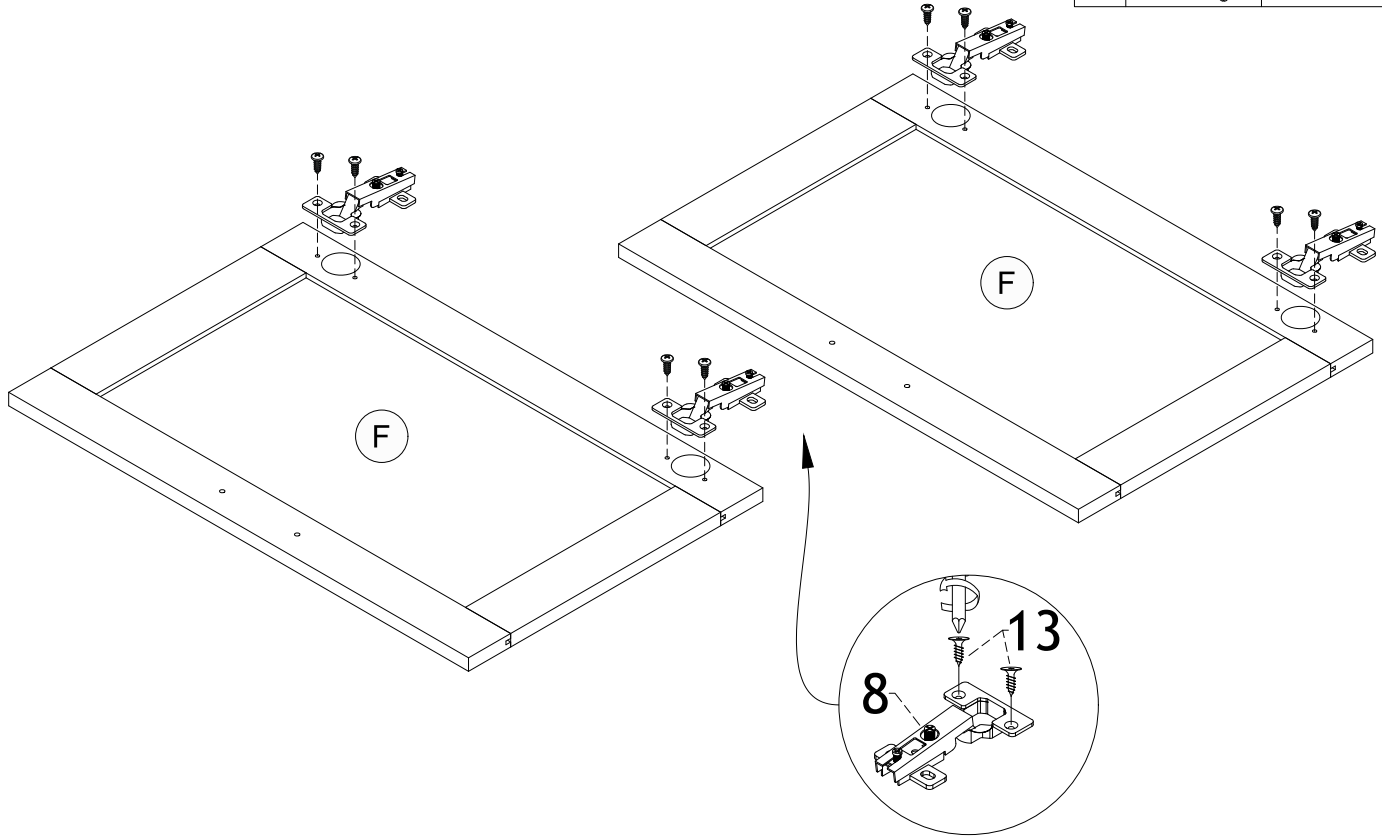

STEP 12

8		4 pcs
13		8 pcs



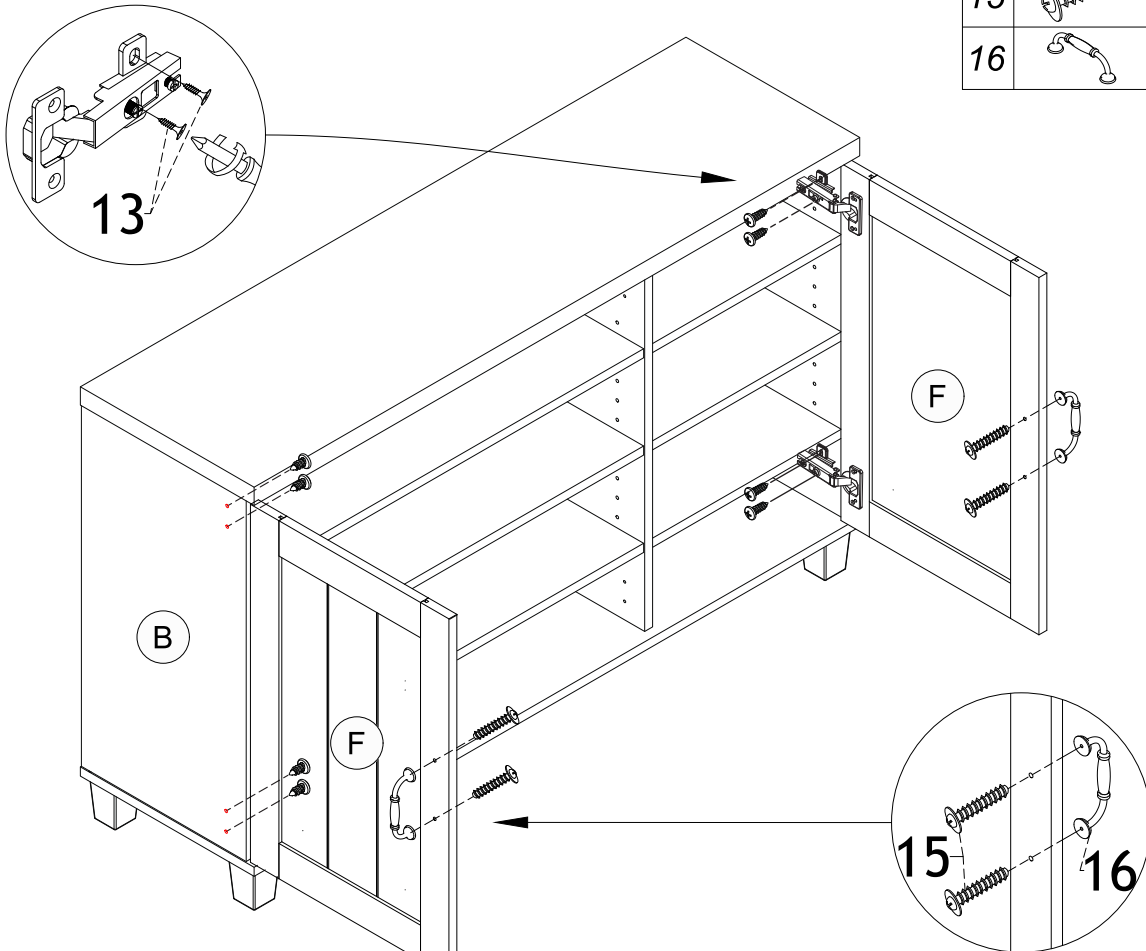

STEP 13

13		8 pcs
15		4 pcs
16		2 pcs



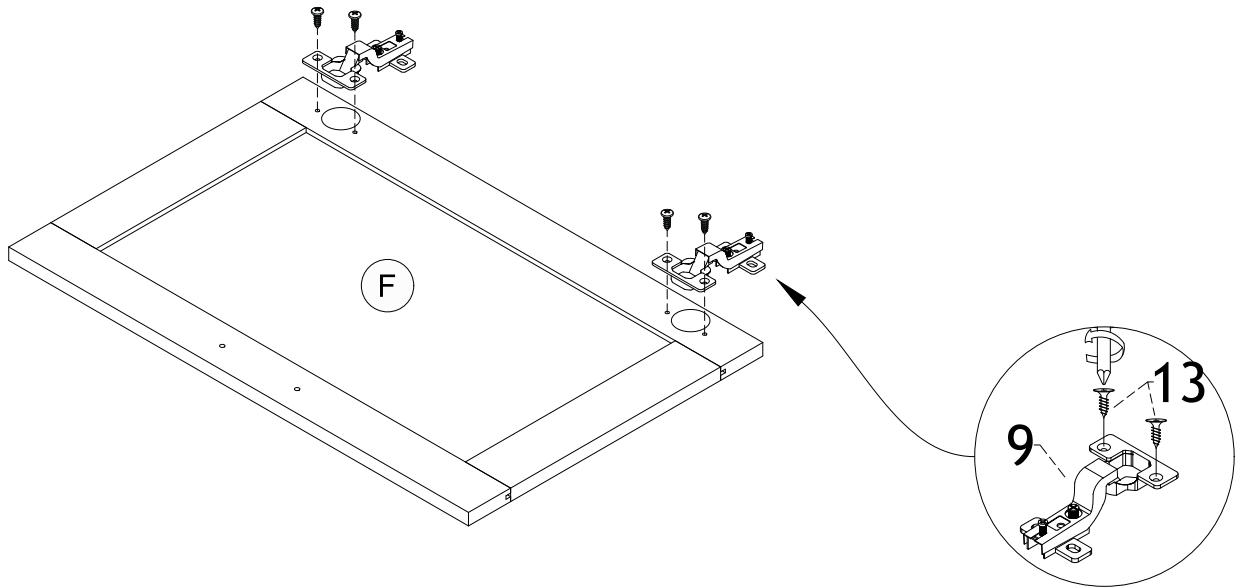

STEP 14

9		2 pcs
13		4 pcs



STEP 15

13		4 pcs
15		2 pcs
16		1 pc

