

ASSEMBLY INSTRUCTION

INSTRUCTIONS DE MONTAGE

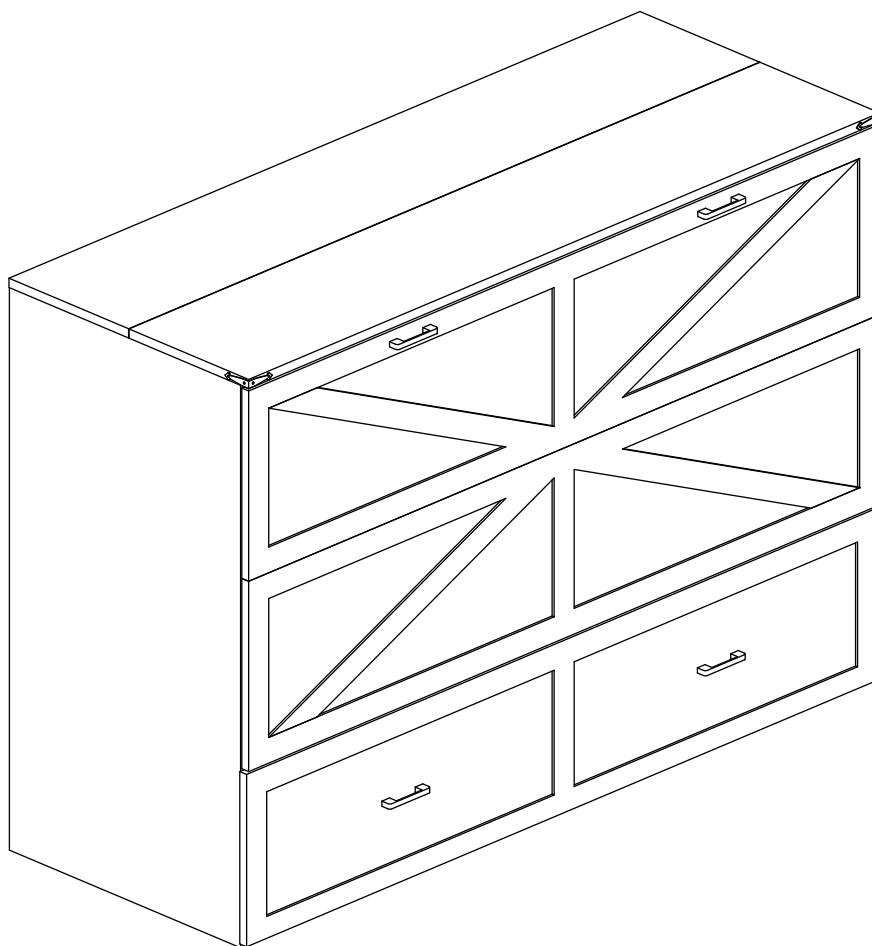

Detail view:

vue détaillée:

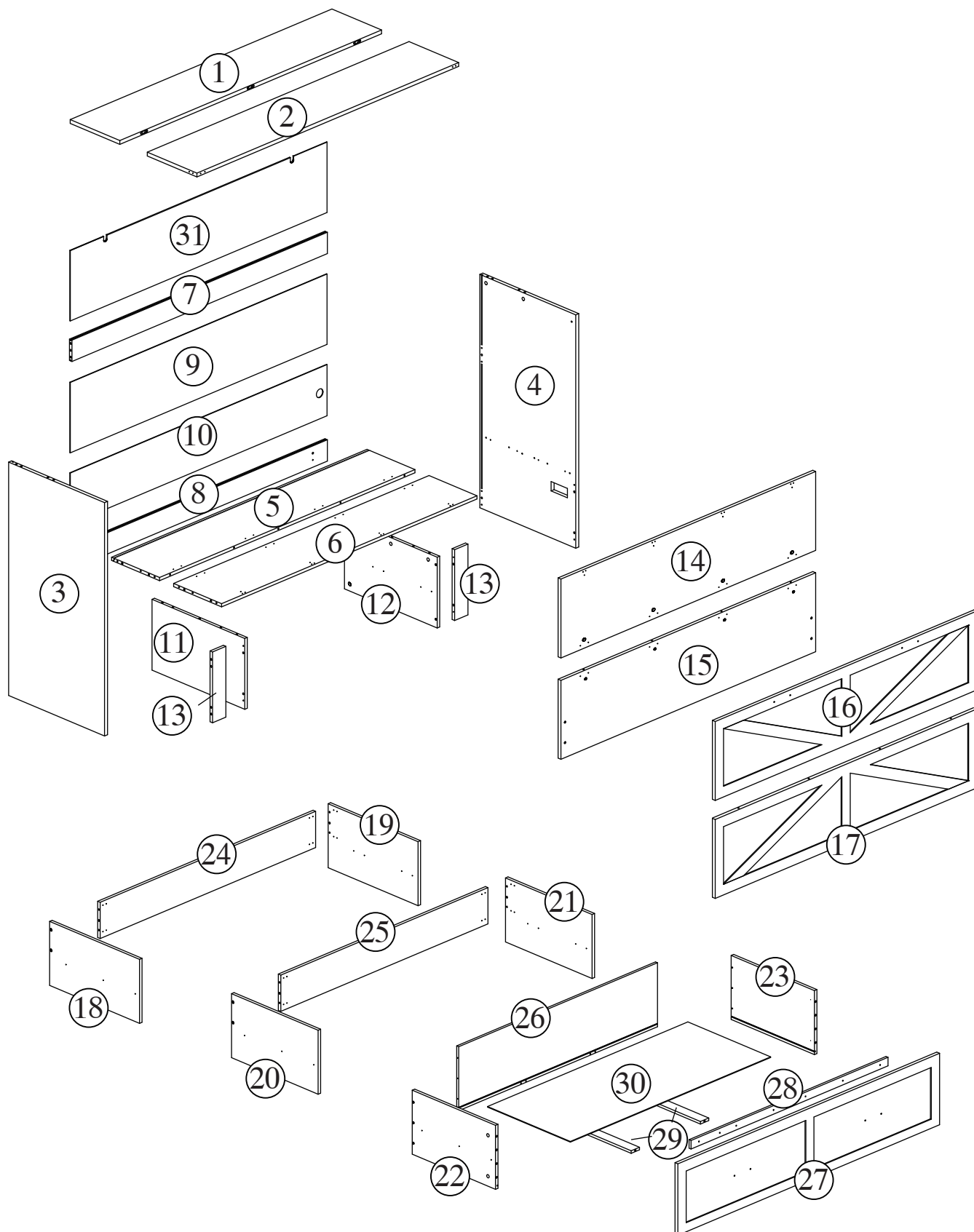

Part List & Hardware List(Box 1)
 Liste des pièces & Liste du matériel (boîte 1)

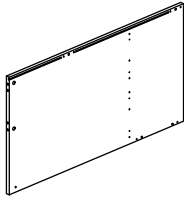
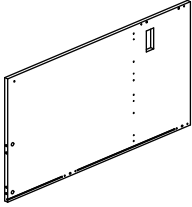
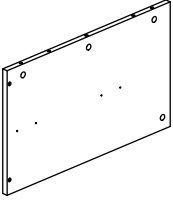
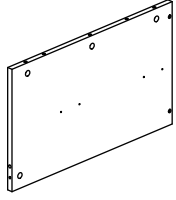
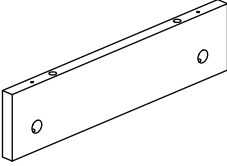
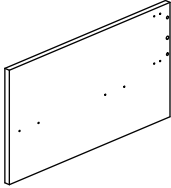
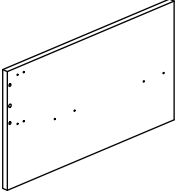
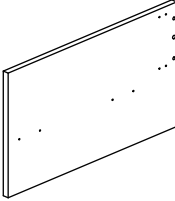
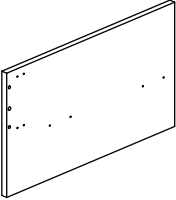
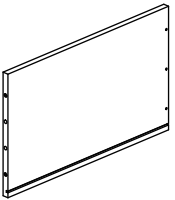
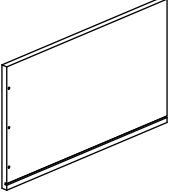
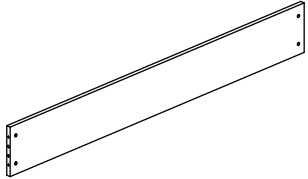
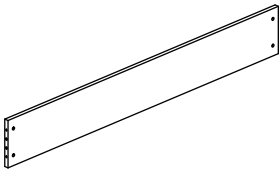
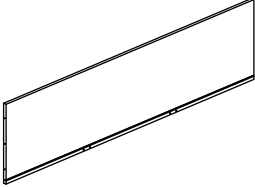
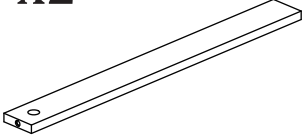
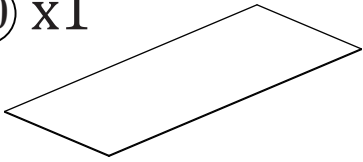
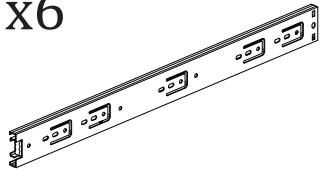
<p>③ x1</p> 	<p>④ x1</p> 	
<p>⑪ x1</p> 	<p>⑫ x1</p> 	
<p>⑬ x2</p> 	<p>⑱ x1</p> 	
<p>⑲ x1</p> 	<p>⑳ x1</p> 	
<p>㉑ x1</p> 	<p>㉒ x1</p> 	
<p>㉓ x1</p> 	<p>㉔ x1</p> 	
<p>㉕ x1</p> 	<p>㉖ x1</p> 	
<p>㉙ x2</p> 	<p>⑳ x1</p> 	<p>Y x6</p> 

Part List(Box 2)
Liste des pièces (boîte 2-)

① x1

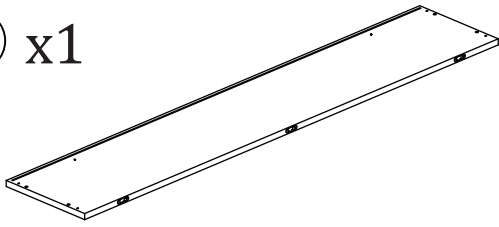

② x1

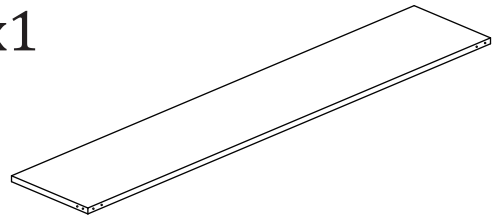

①⑥ x1

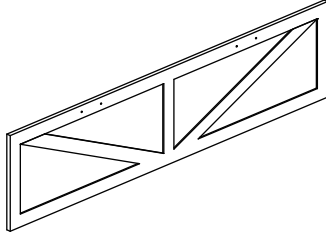

①⑦ x1

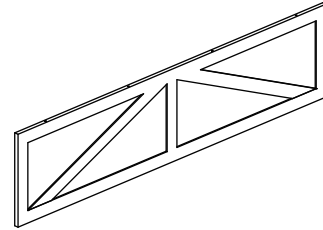

②⑦ x1

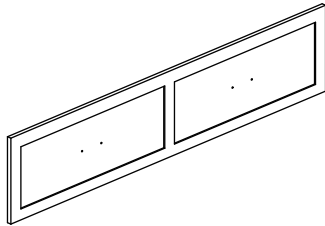

Part List(Box 3)
Liste des pièces (boîte 3-)

⑤ x1

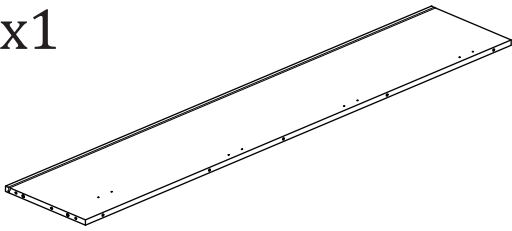

⑥ x1

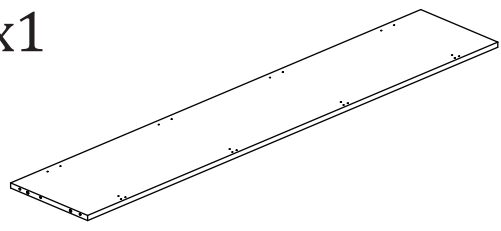

⑦ x1

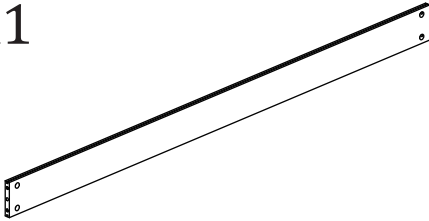

⑧ x1

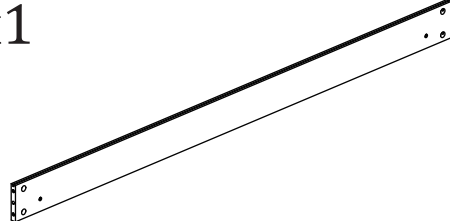

⑨ x1

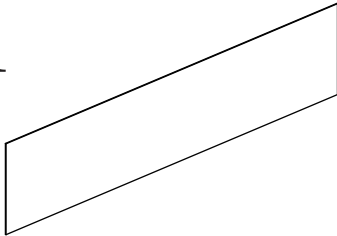

⑩ x1

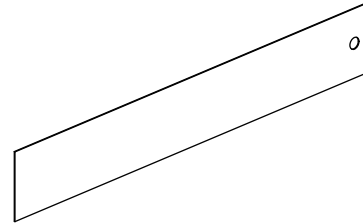

⑭ x1

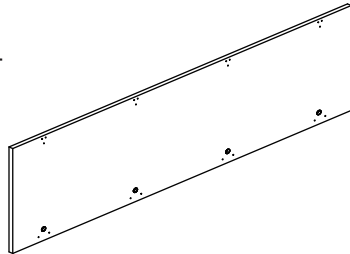

⑮ x1

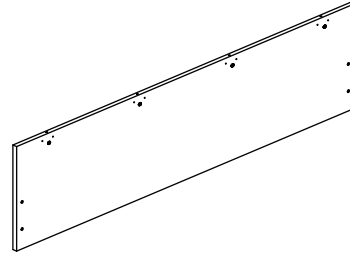



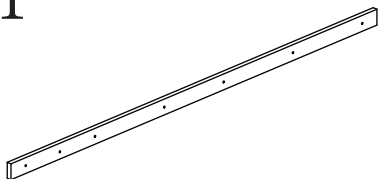

⑳ x1

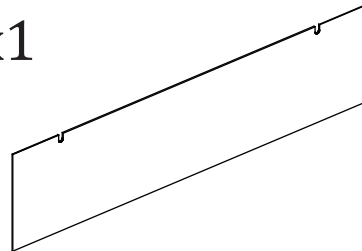

㉓ x1

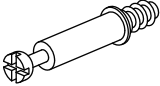

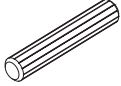
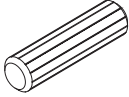
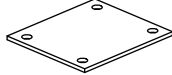
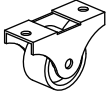
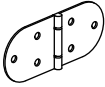
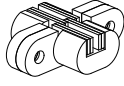
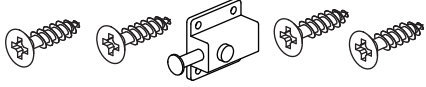
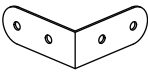
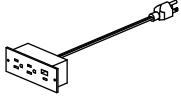

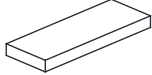
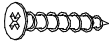



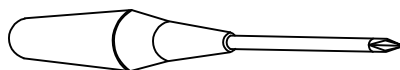

Part List & Hardware List(Box 1)
 Liste des pièces & Liste du matériel (boîte 1)

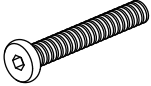
No.	OUTLOOK	DESC	QTY
(A)			36
(B)			44
(C)		Dowel Ø 6*30mm Cheville	42
(D)		Dowel Ø 8*40mm Cheville	5
(E)			12
(F)		Wheels roues	12
(G)		Hinge Charnière	8
(H)		Hinge Charnière	3
(I)		Fastener La boucle	2
(J)		Base L Base	8
(K)		Socekt Le rang	1
(L)		Back plate buckle Backplate avec boucle	14
(M)			16
(N)		Screws Ø 4*25mm Des vis	7

ASSEMBLY TOOLS REQUIRED (NOT INCLUDED)/OUTILS D'ASSEMBLAGE REQUIS (NON INCLUS)

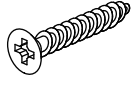
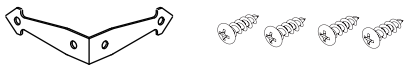

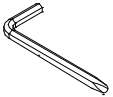
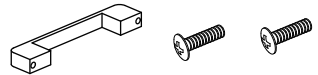
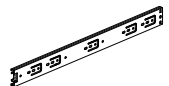
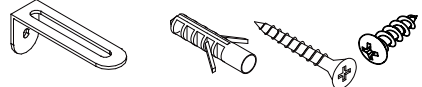
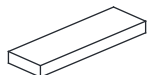
Part List & Hardware List(Box 1)
 Liste des pièces & Liste du matériel (boîte 1)

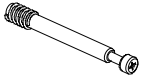
No.	OUTLOOK	DESC	QTY
○		Bolts Ø 6*50mm Boulons	8
○			16
○		Screws Ø 4*40mm Des vis	16
○		Screws Ø 4*18mm Des vis	24
○		Screws Ø 3*25mm Des vis	12
○			2
○		Screws Ø 4*16mm Des vis	170
○		Screws Ø 3*14mm Des vis	2
○		Allebn key clé Allen	1
○		Handle De montures	6
○		Slideway Le patin	6
○		L - shaped anti - reverse Anti - retour en forme de L	2
○		Corner pad Tapis de la corne de l' afrique	4
○			4
○			8

ASSEMBLY TOOLS REQUIRED (NOT INCLUDED)/OUTILS D'ASSEMBLAGE REQUIS (NON INCLUS)

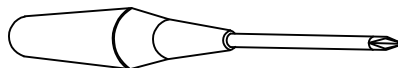

STEP 1:

Étape

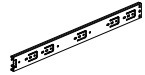

Please open the slide by pressing the buckle.
Veuillez ouvrir la glissière en appuyant sur la boucle.

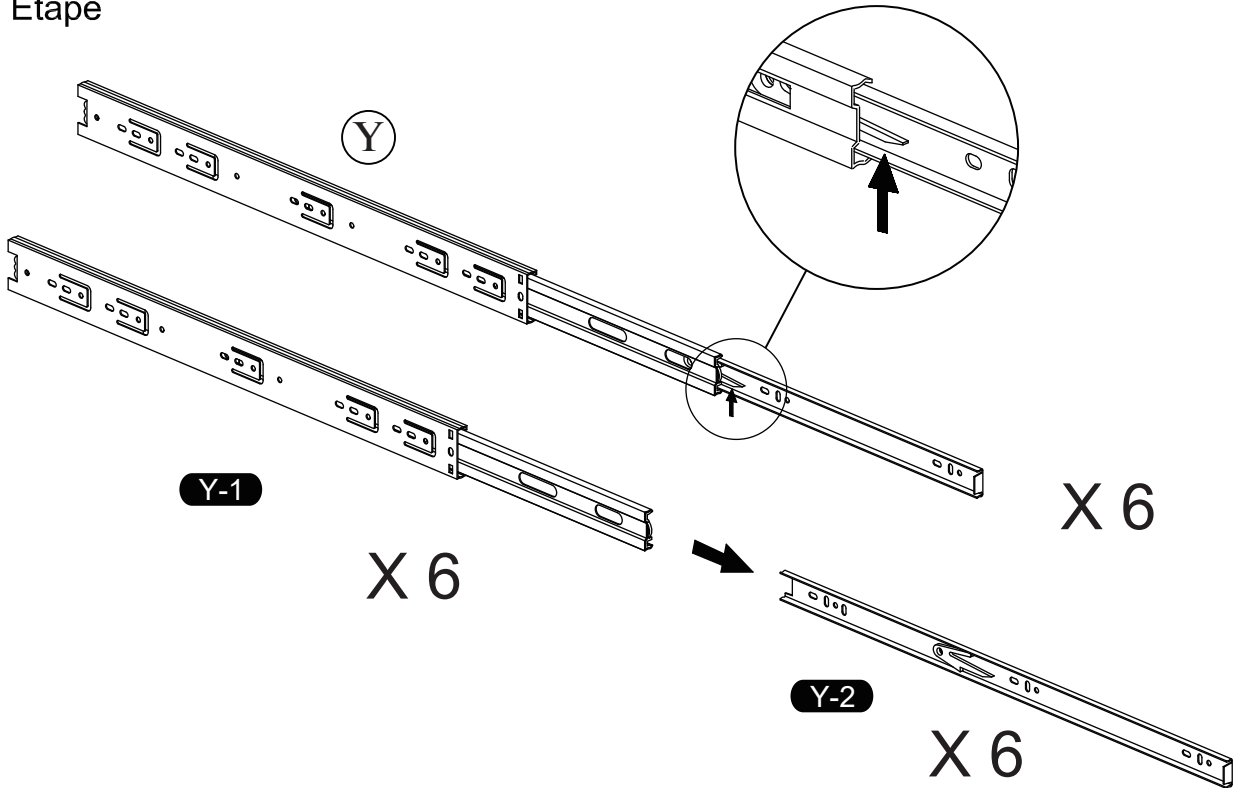
Y		06
---	--	----



STEP 2:

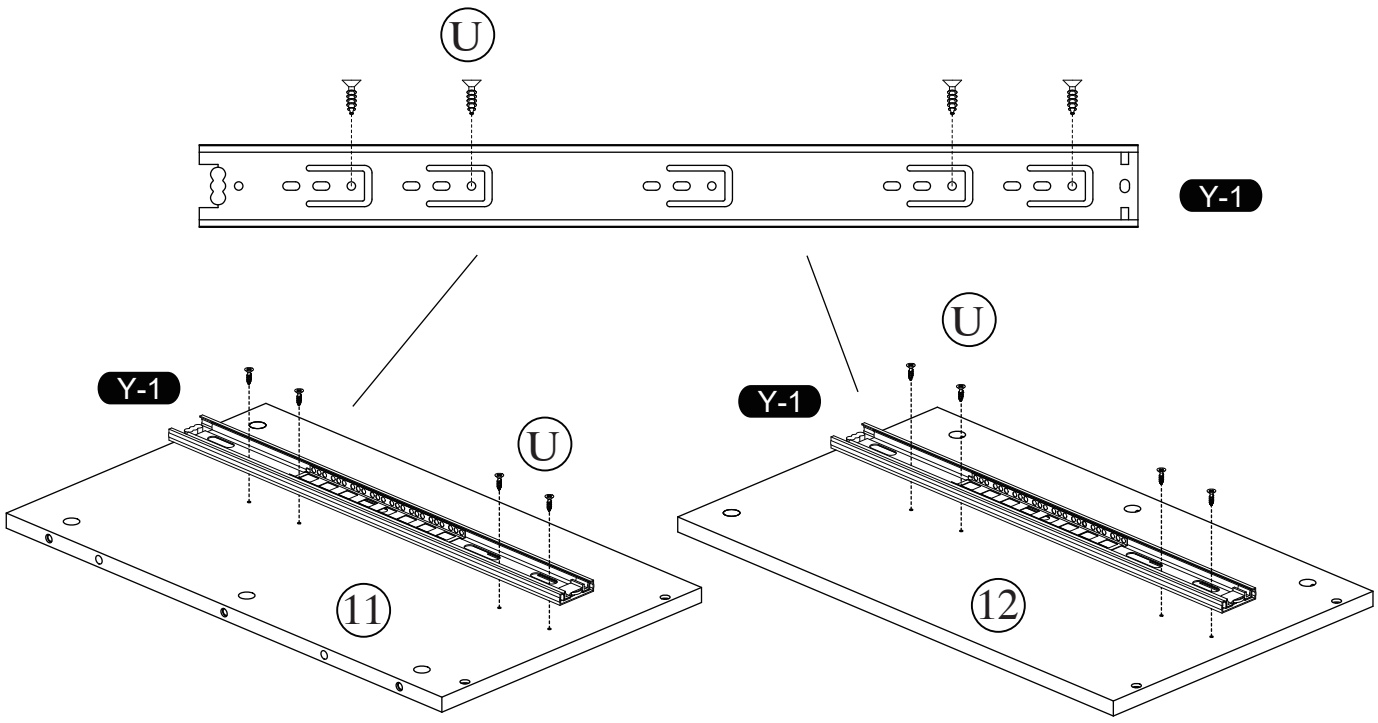

Étape

U		4*16mm	08
Y		Y-1	02



STEP 3:

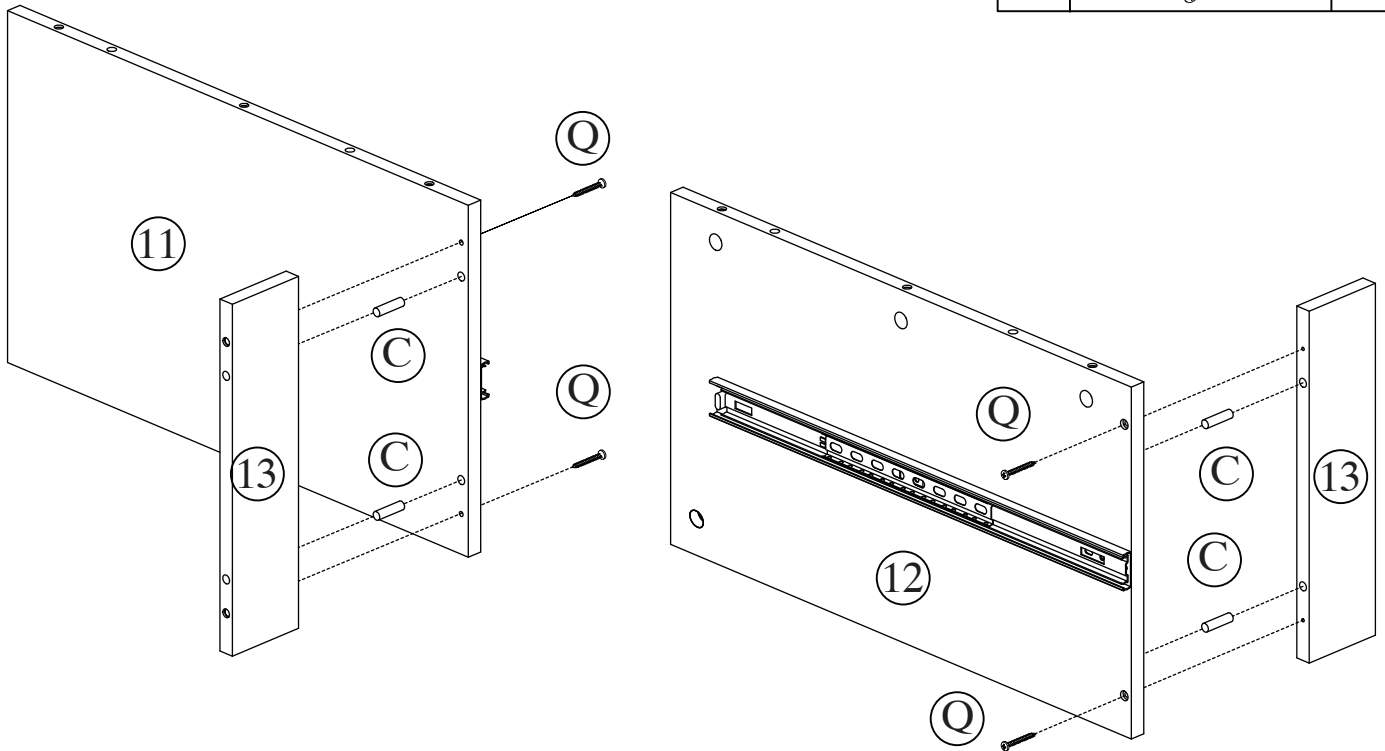

Étape

(C)		6*30mm	04
(Q)		4*40mm	04

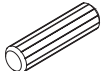

STEP 4:

Étape

(D)		8*40mm	05
(E)			04
(U)		4*16mm	16

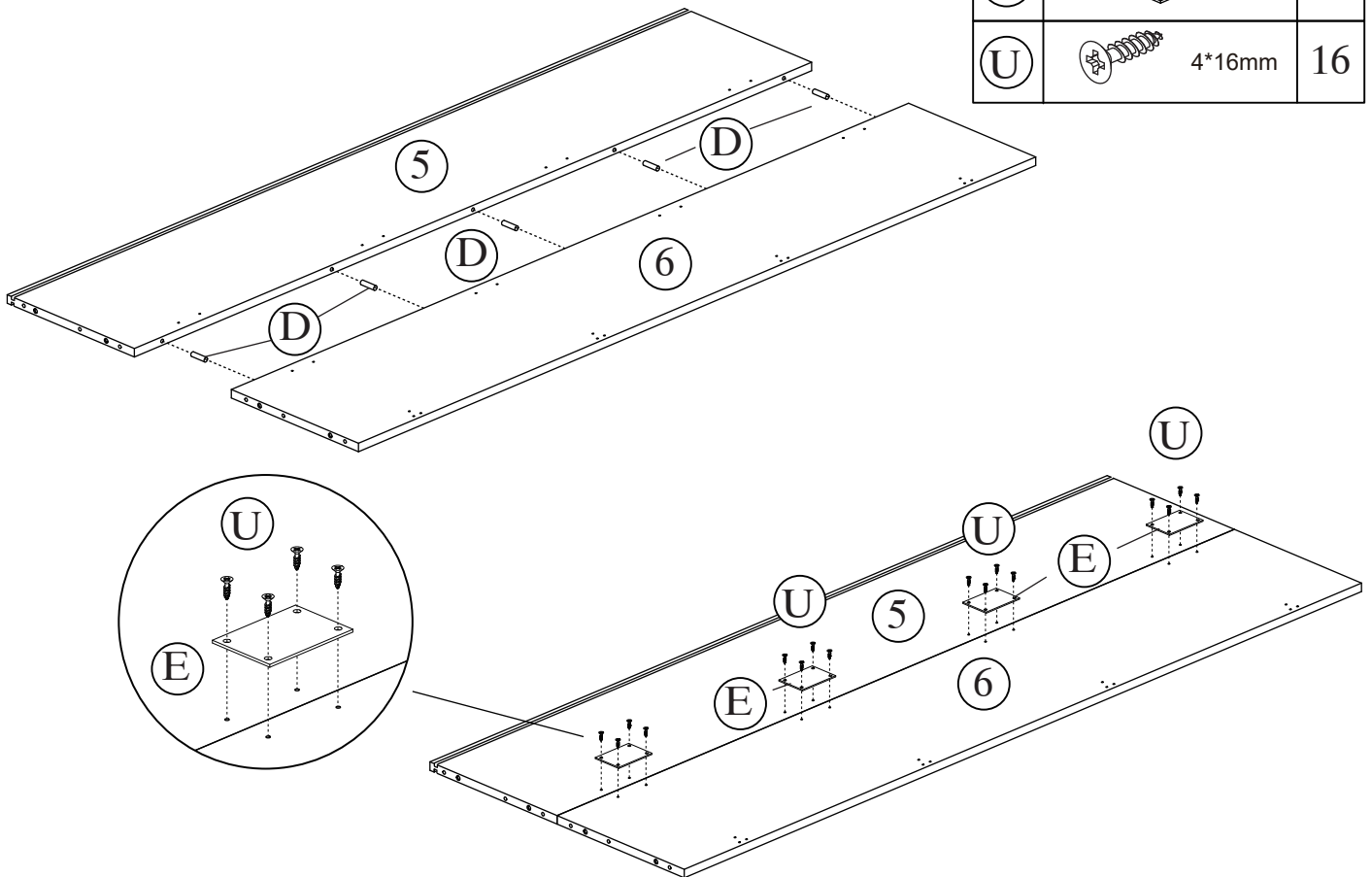

STEP 5:

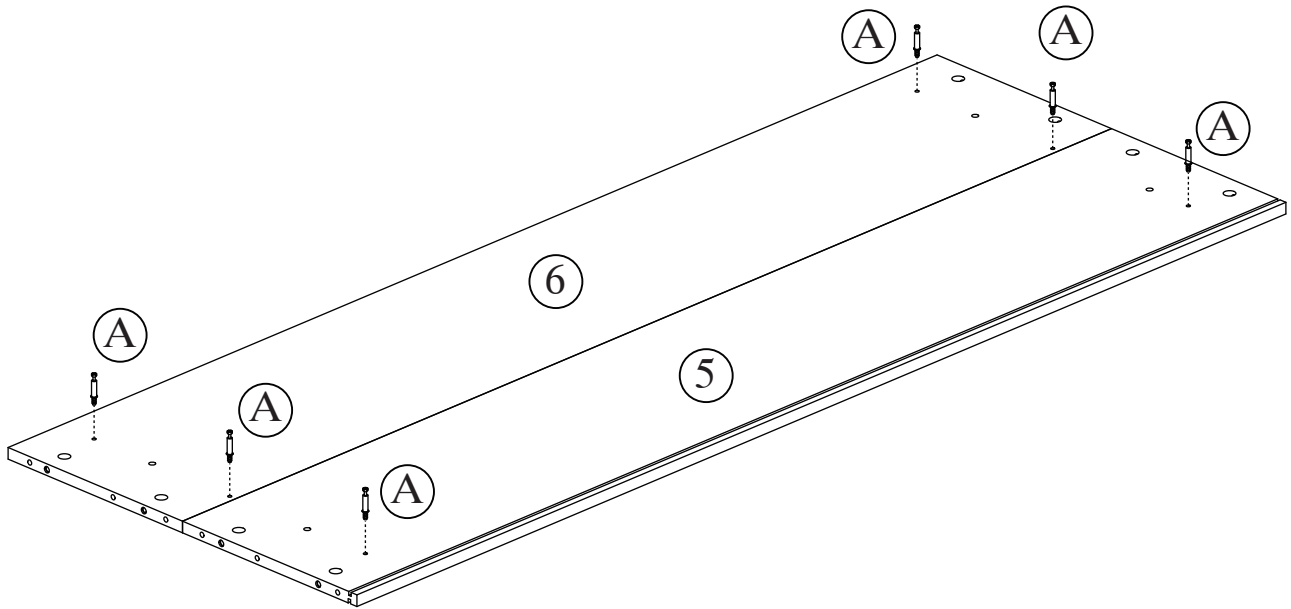

Étape

(A)		06
-----	---	----



STEP 6:

Étape

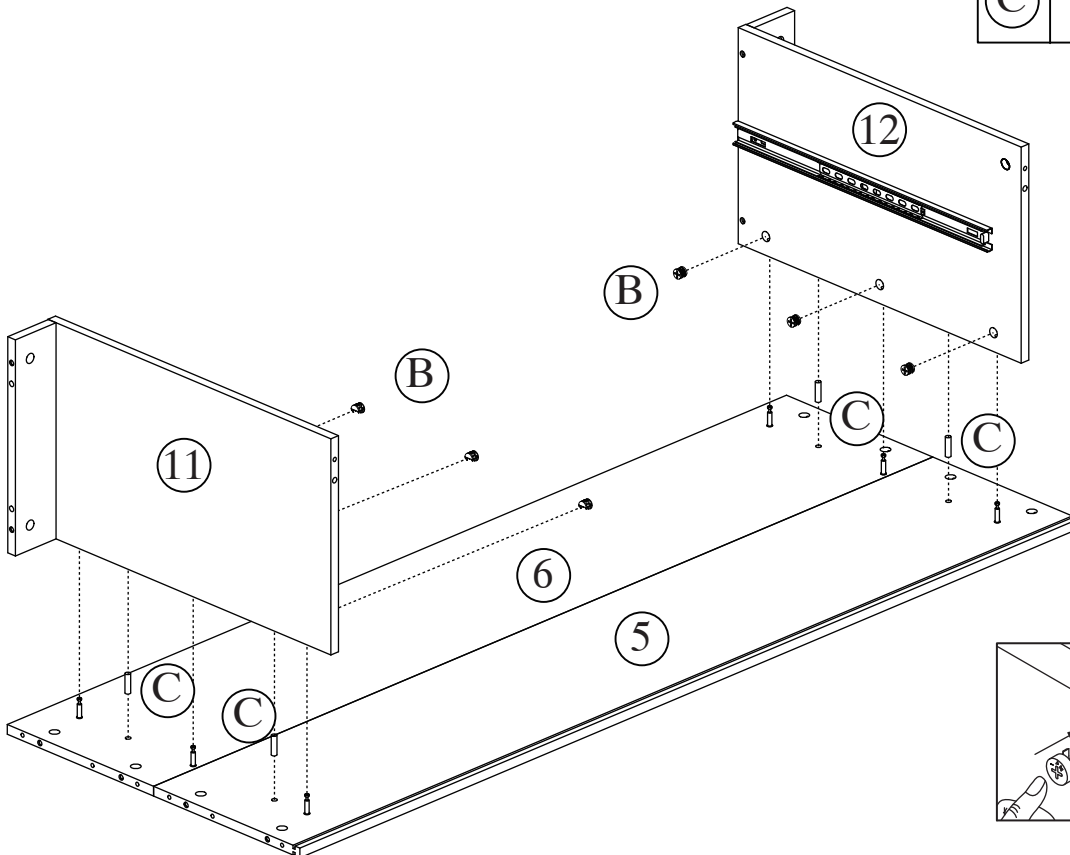

(B)		06
(C)	 6*30mm	04

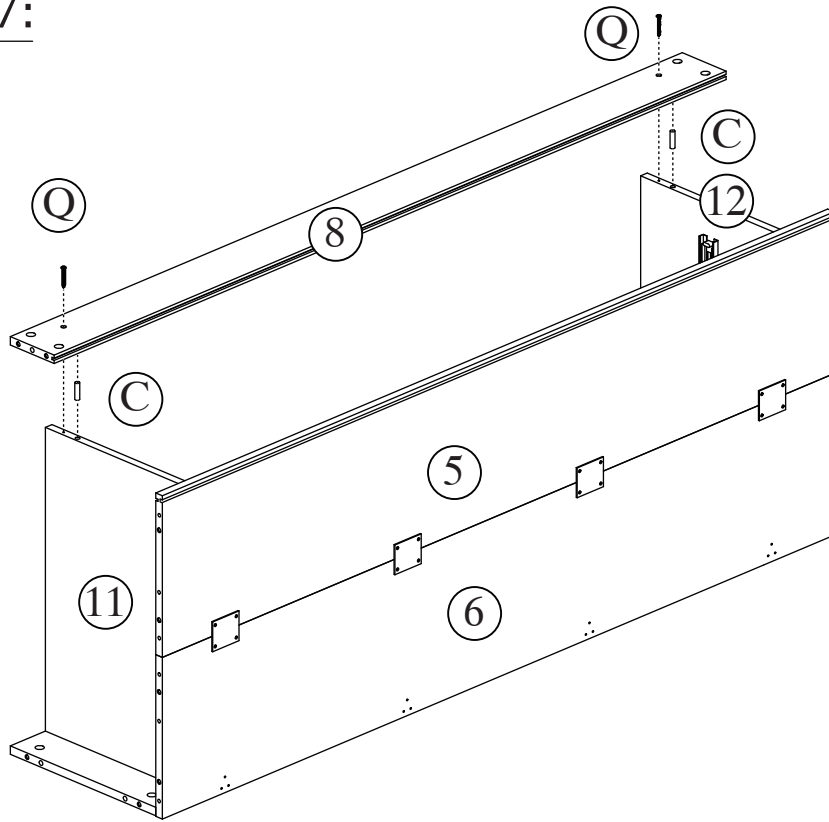

STEP 7:

Étape



(C)		6*30mm	02
(Q)		4*40mm	02

STEP 8:

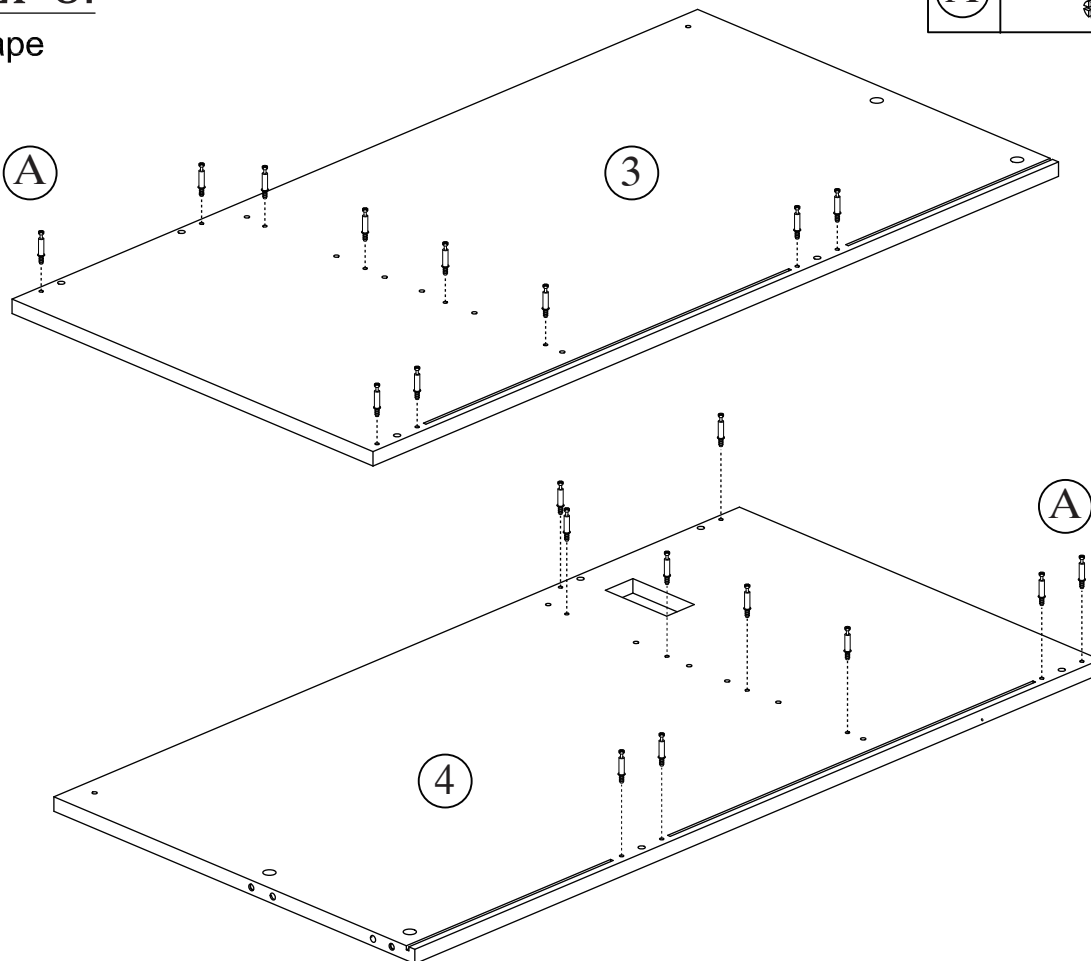

Étape



(A)			20
-----	---	--	----

STEP 9:

Étape

(B)		08
(C)	 6*30mm	09

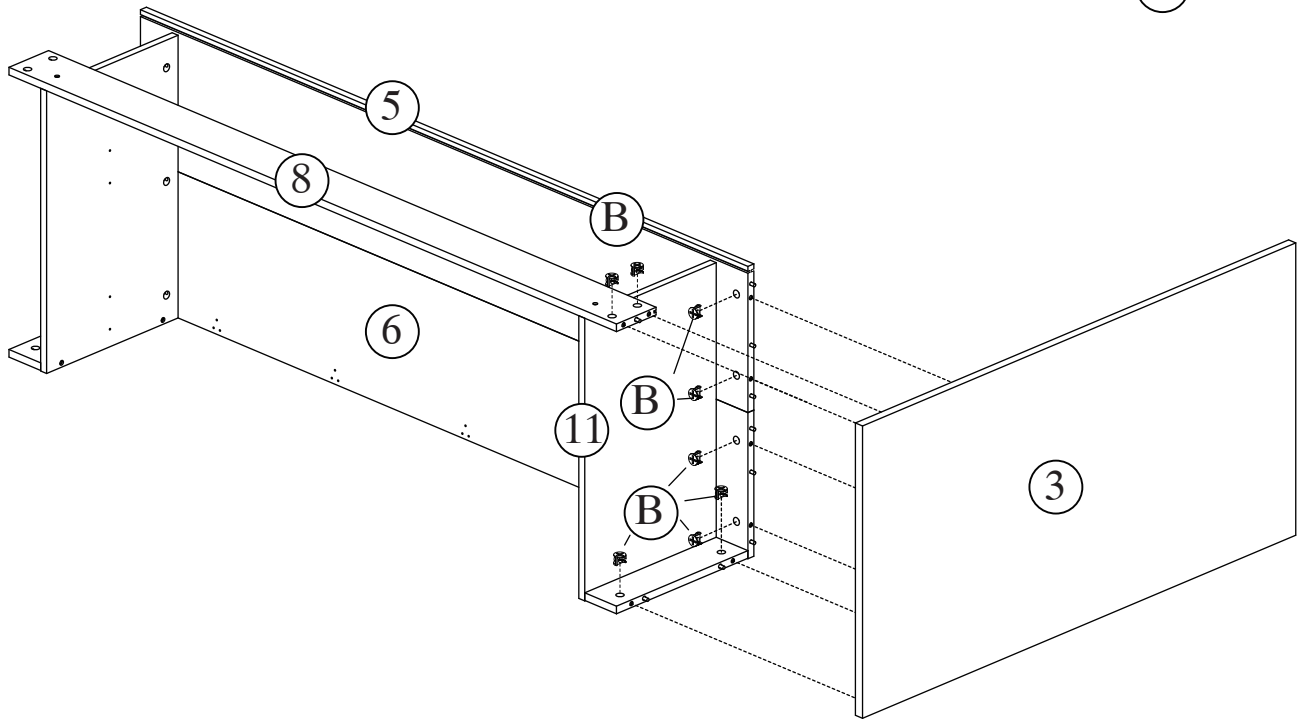
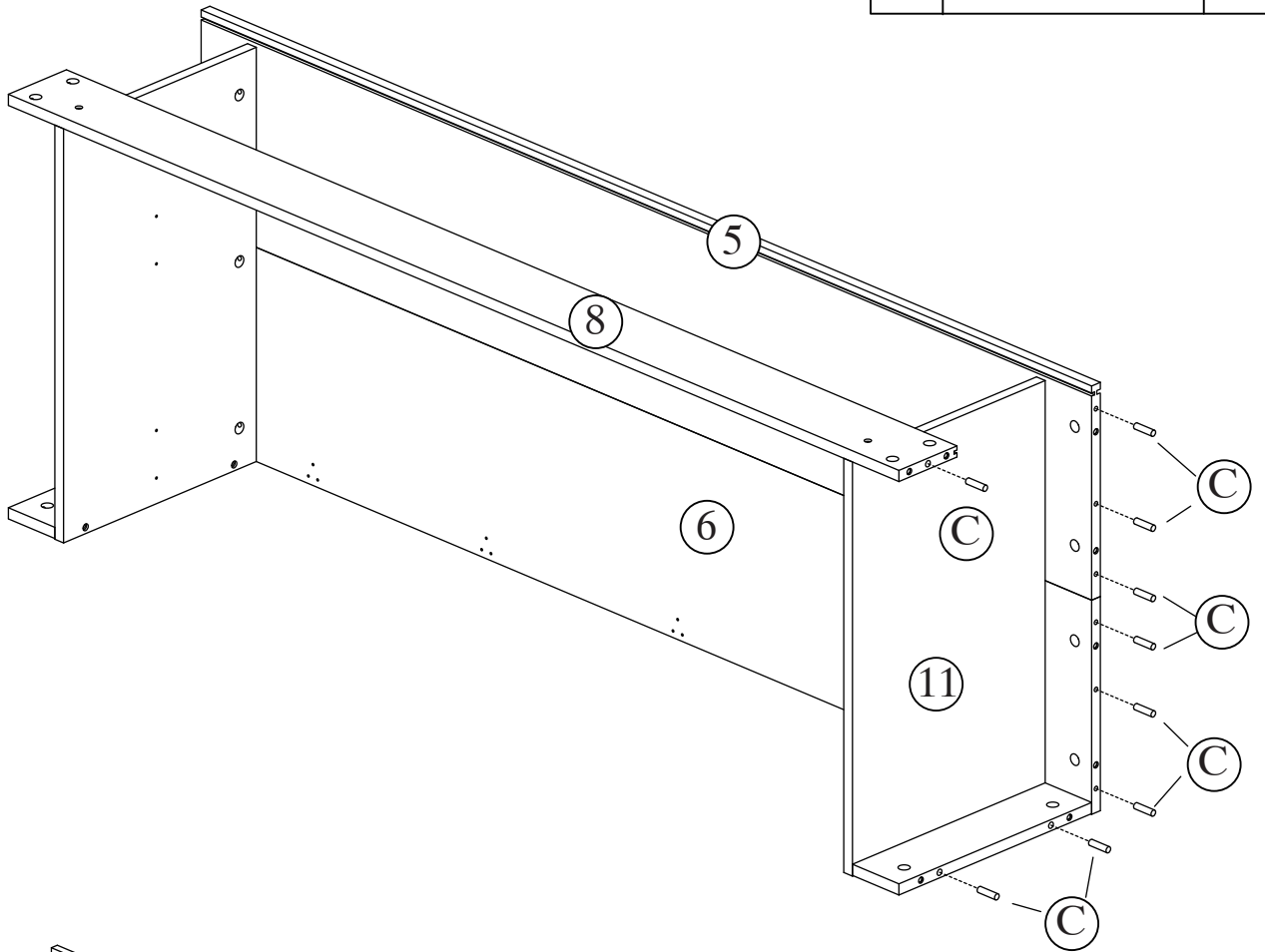

STEP 10:

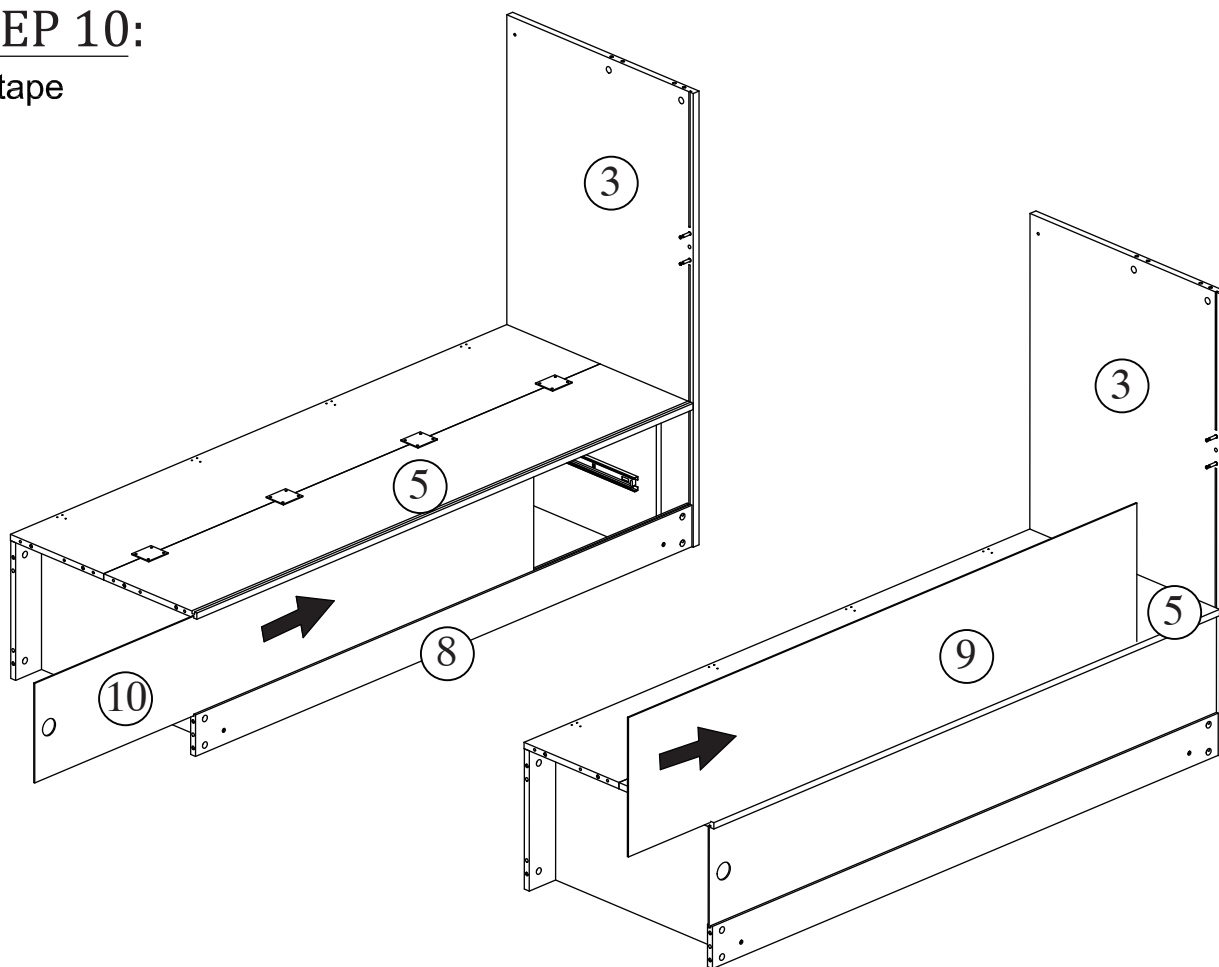

Étape

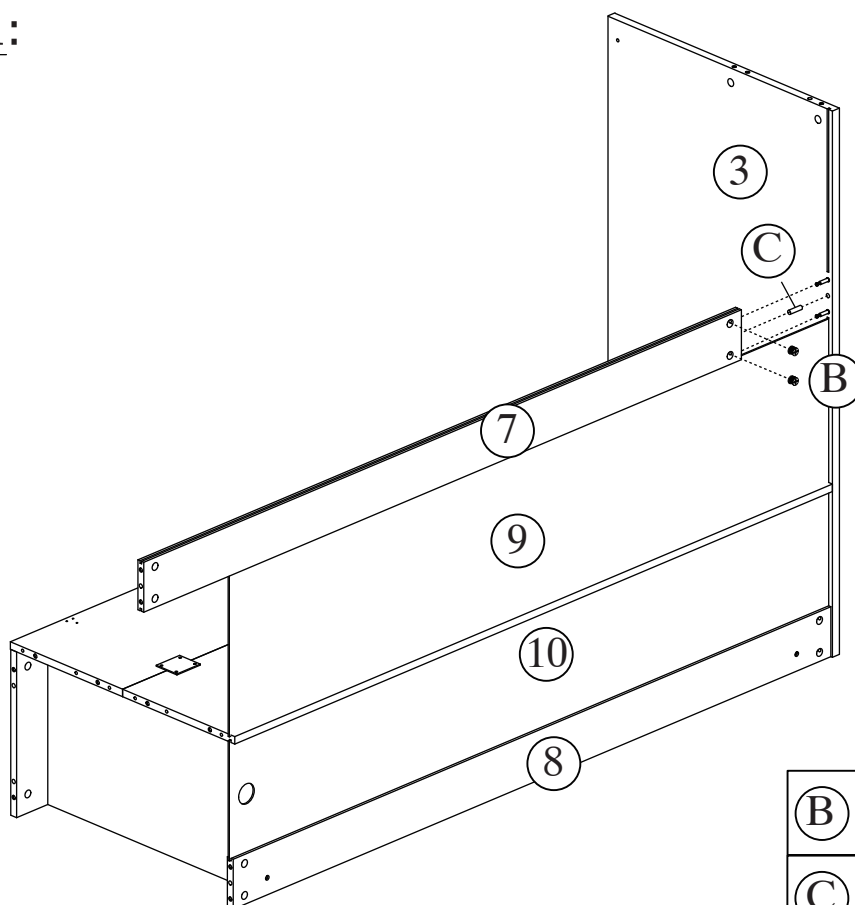

STEP 11:

Étape



(B)		02
(C)	 6*30mm	01

STEP 12:

Étape

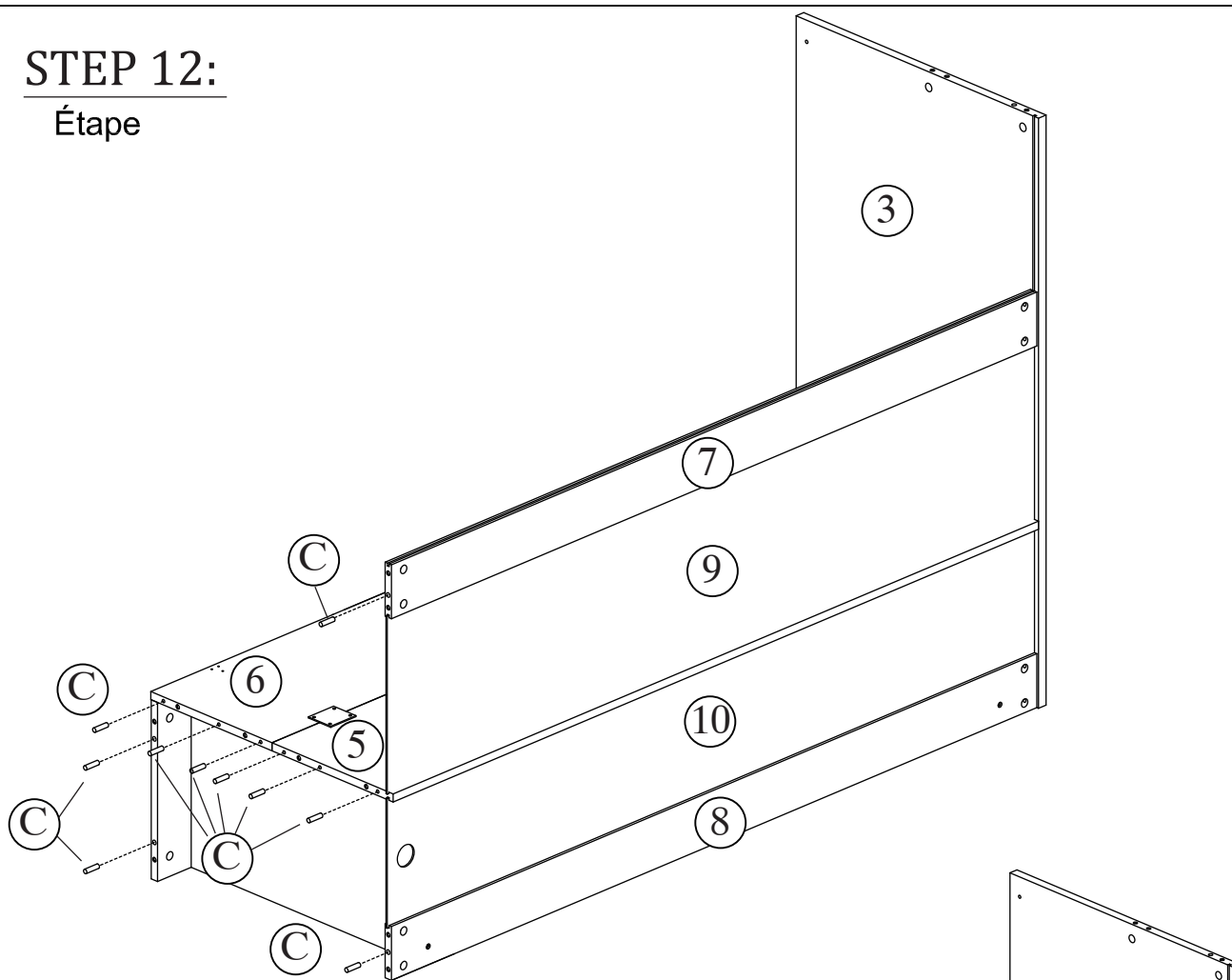

After installing the No. 4 side plate, you need to put down the product and lock the screw from the bottom. Please make sure that all side panels are fully stuck in the slot.

Après avoir installé la plaque latérale n ° 4, vous devez déposer le produit et verrouiller la vis par le bas. Veuillez vous assurer que tous les panneaux latéraux sont entièrement coincé dans la fente.

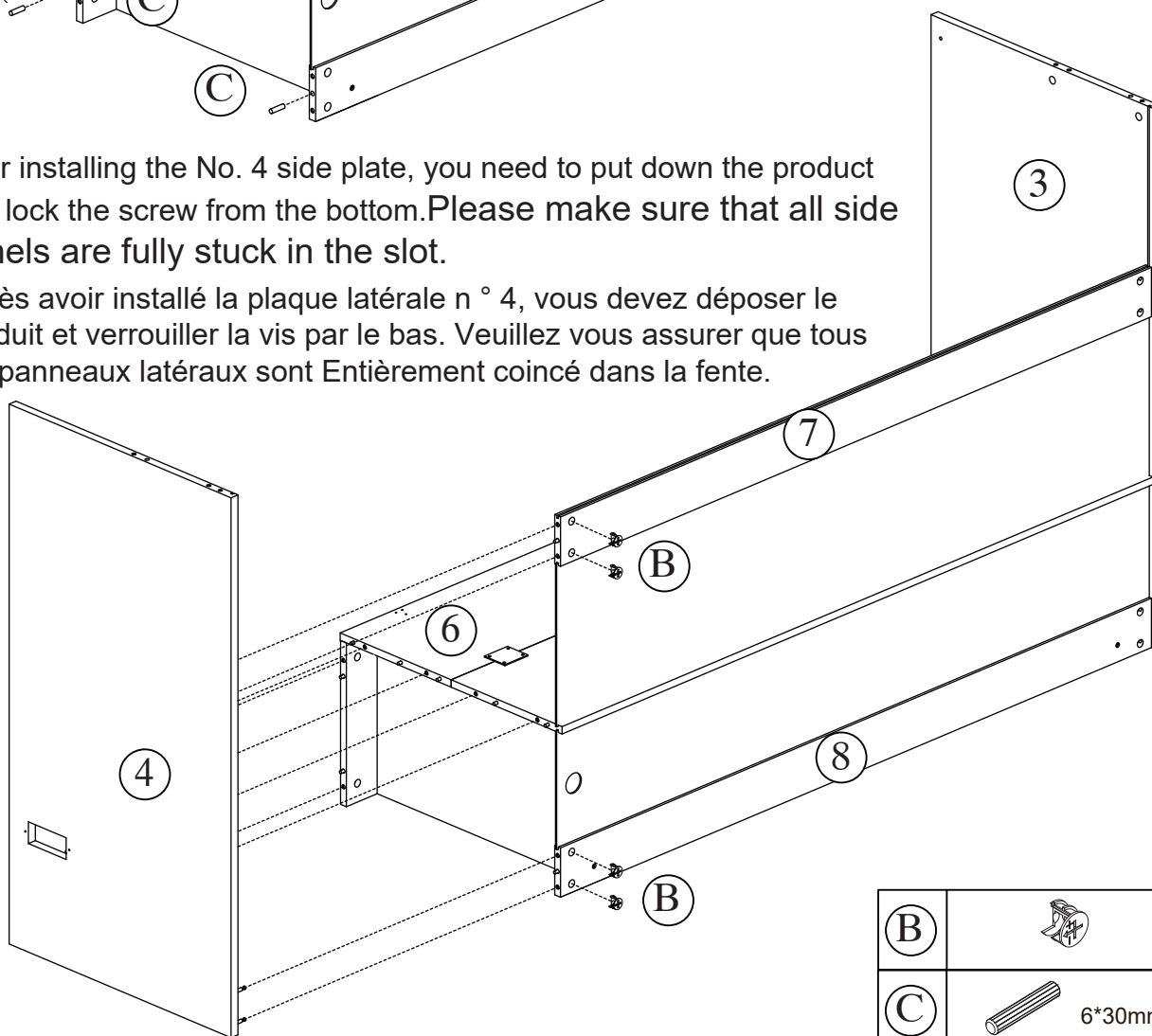

(B)		04
(C)	6*30mm	10

STEP 13:

Étape

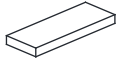
(B)		06
(M)		08

After installing the No. 4 side plate, you need to put down the product and lock the screw from the bottom.

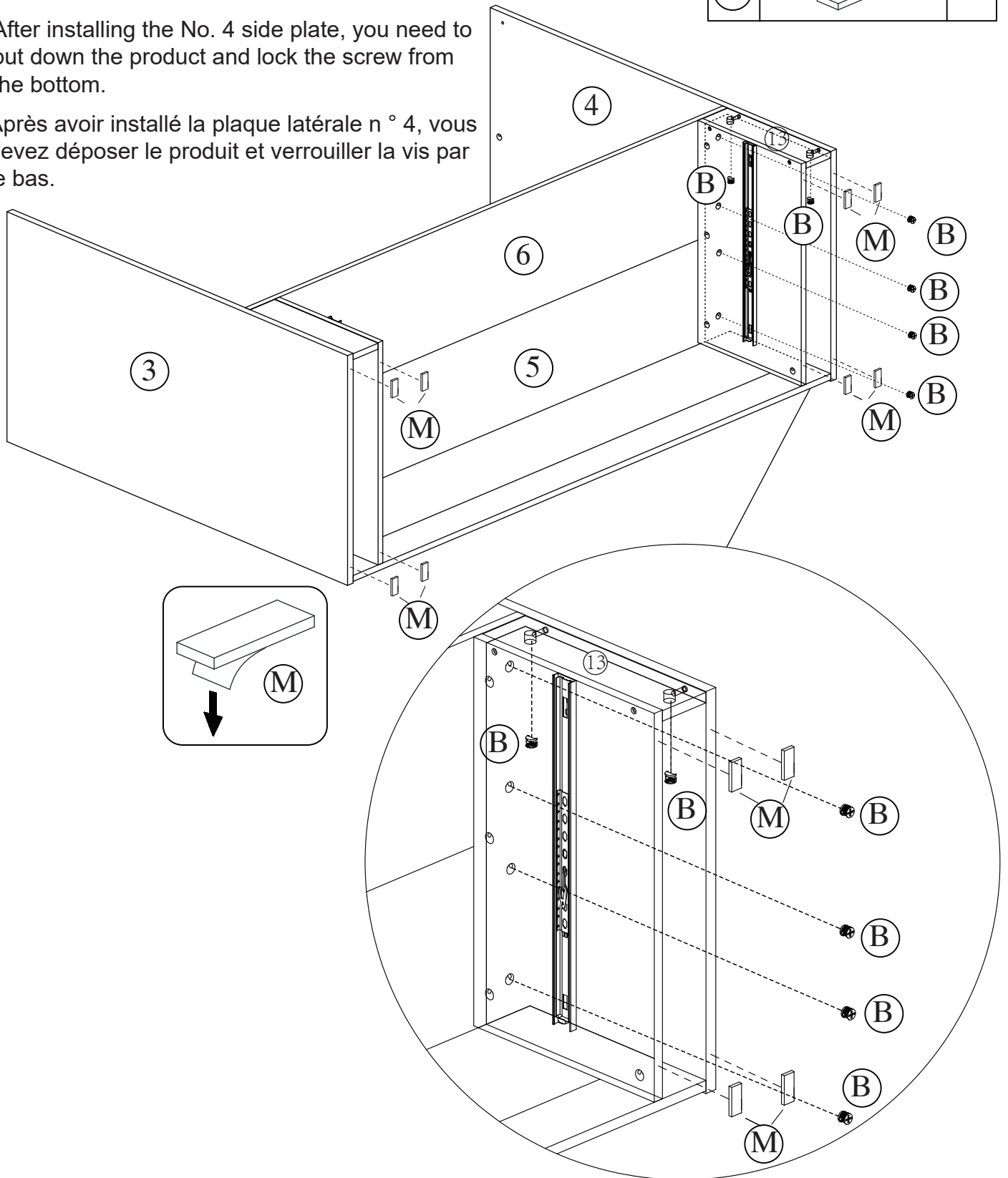

Après avoir installé la plaque latérale n° 4, vous devez déposer le produit et verrouiller la vis par le bas.

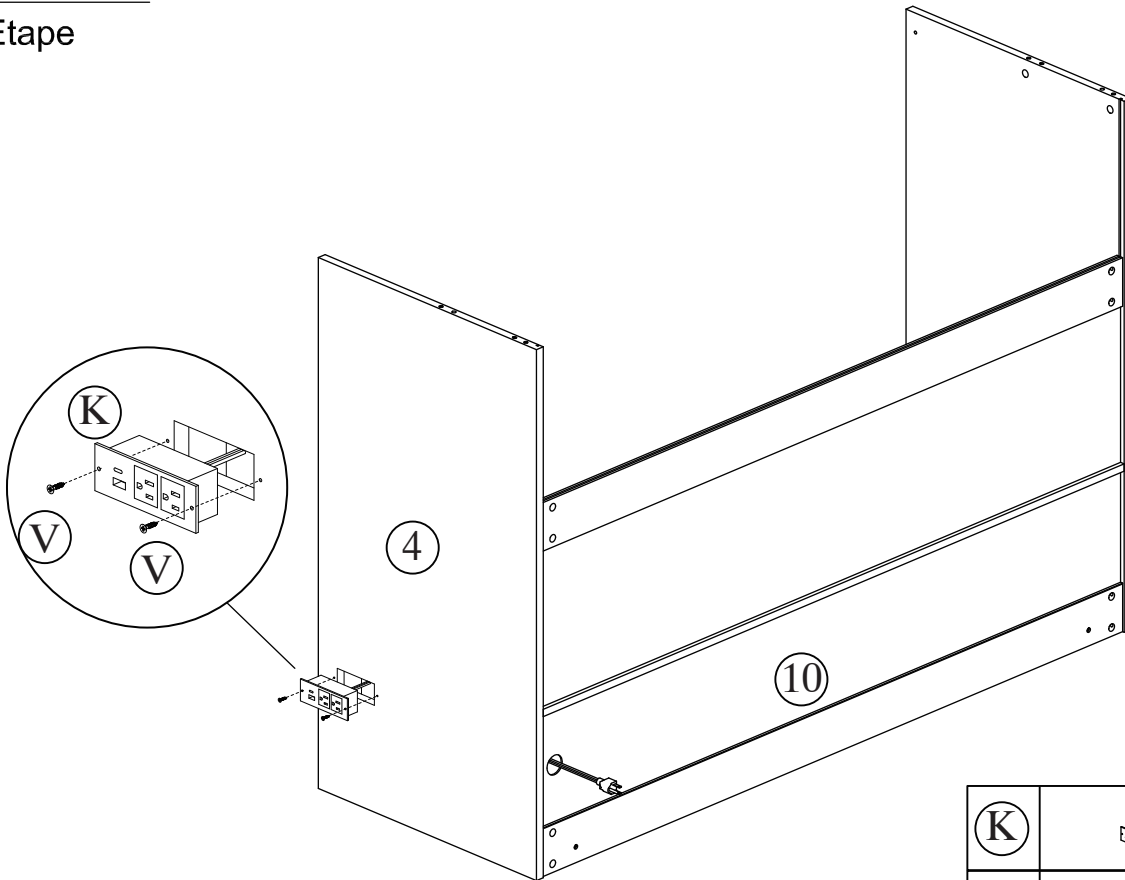

STEP 14:

Étape



(K)		01
(V)	 3*14mm	02

STEP 15:

Étape

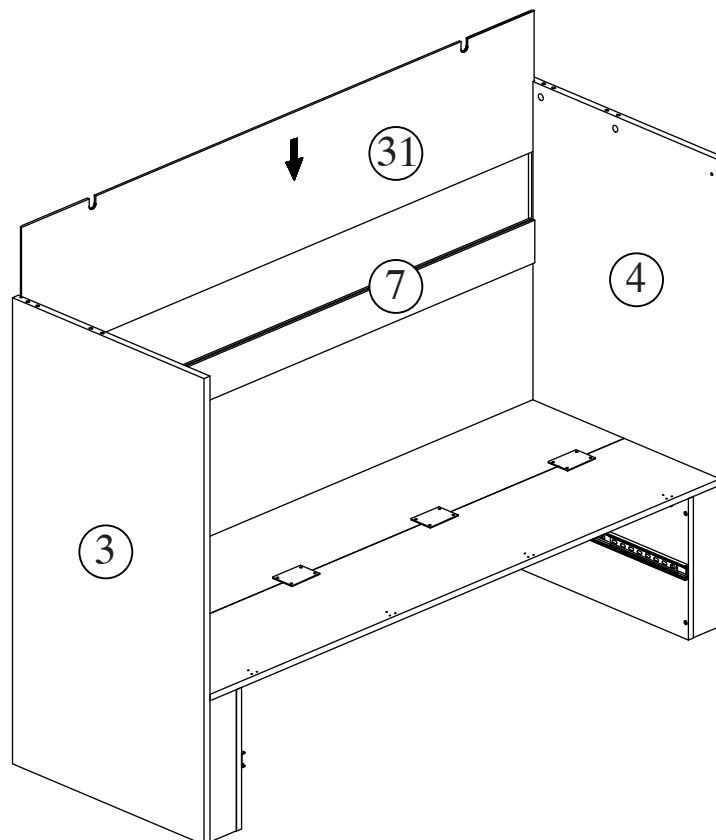

STEP 16:

Étape

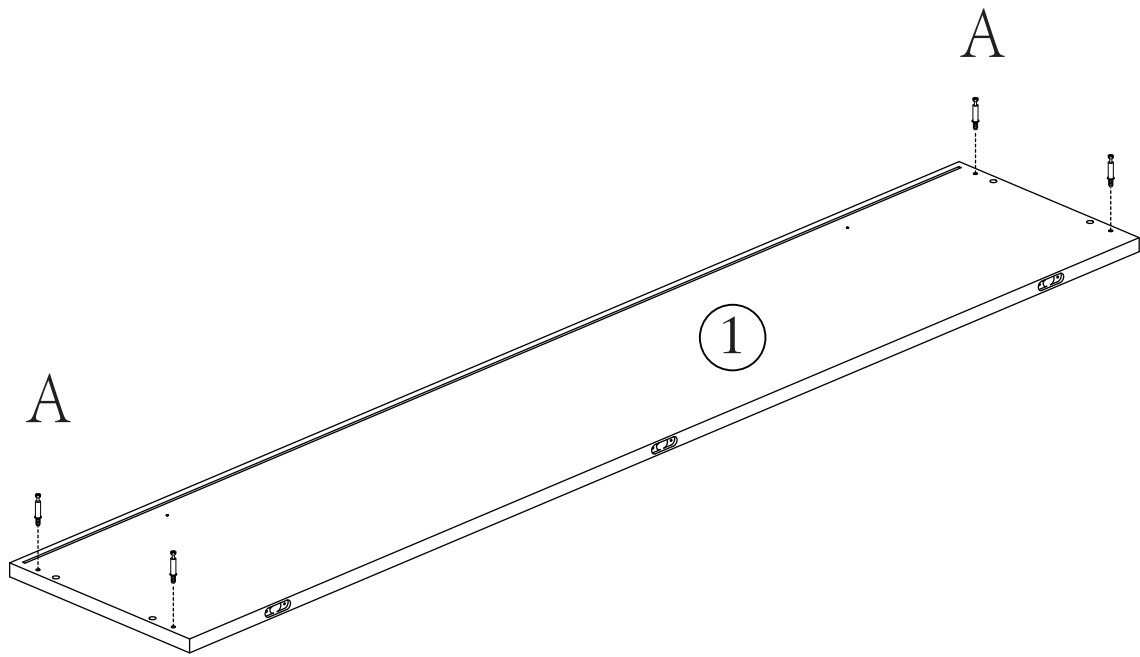



A		04
---	---	----

STEP 17:

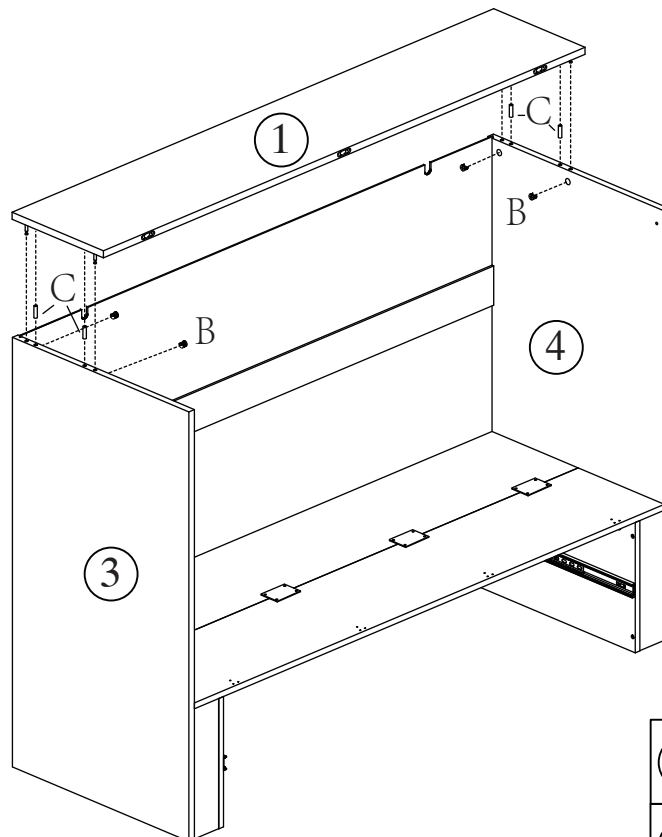
Étape



B		04
C	 6*30mm	04

STEP 18:

Étape

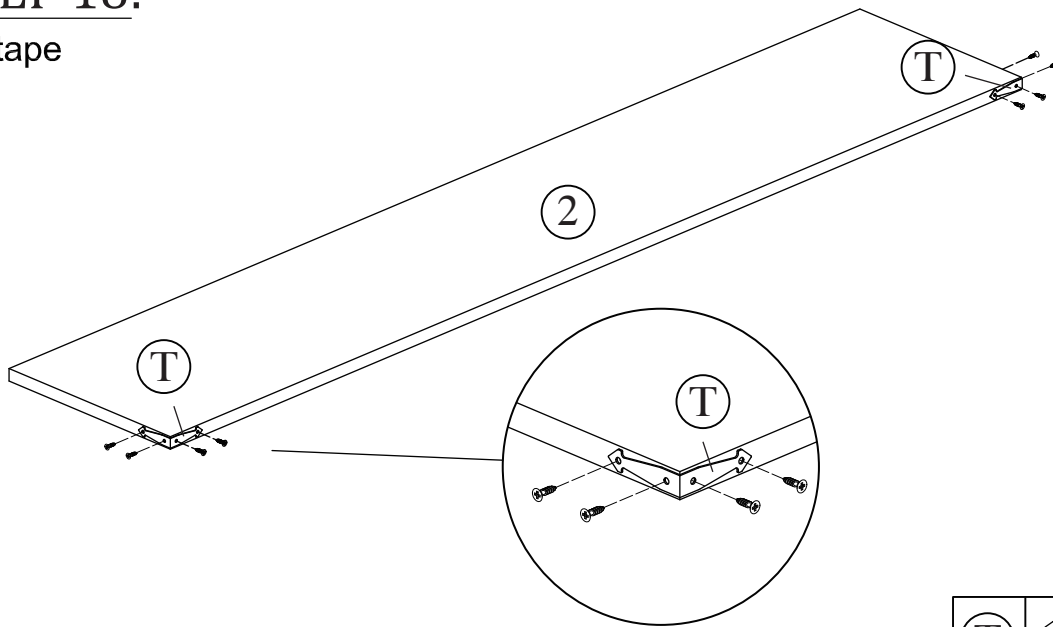



(T)		02
-----	---	----

STEP 19:

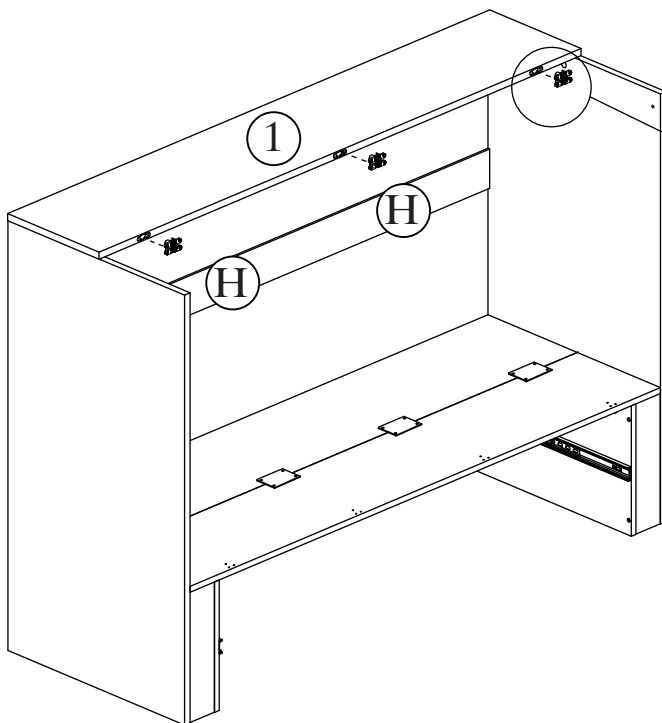
Étape



(H)		03
(S)	 3*25mm	06

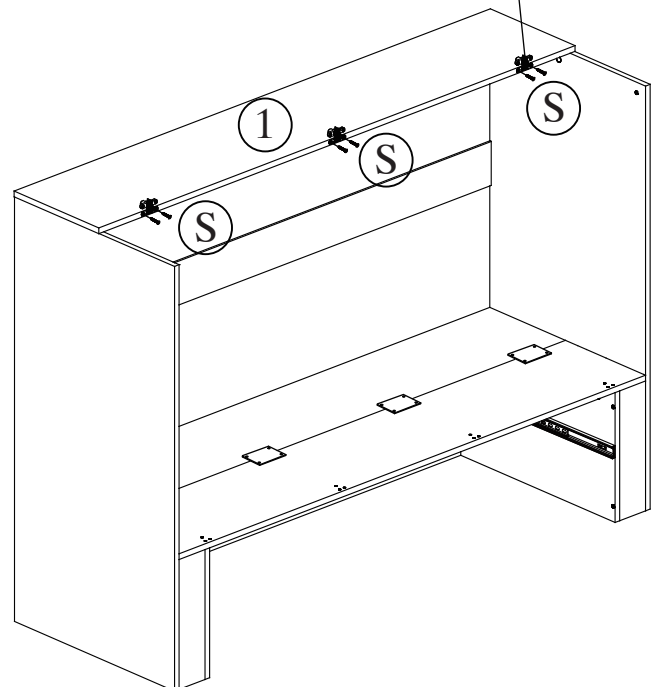
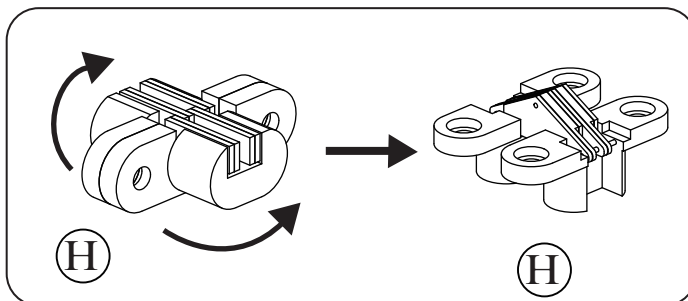
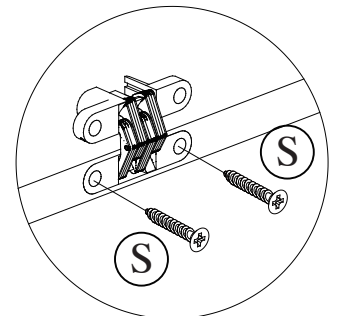
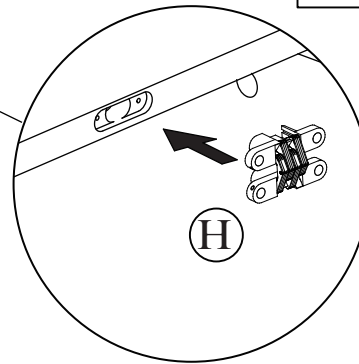

STEP 20:

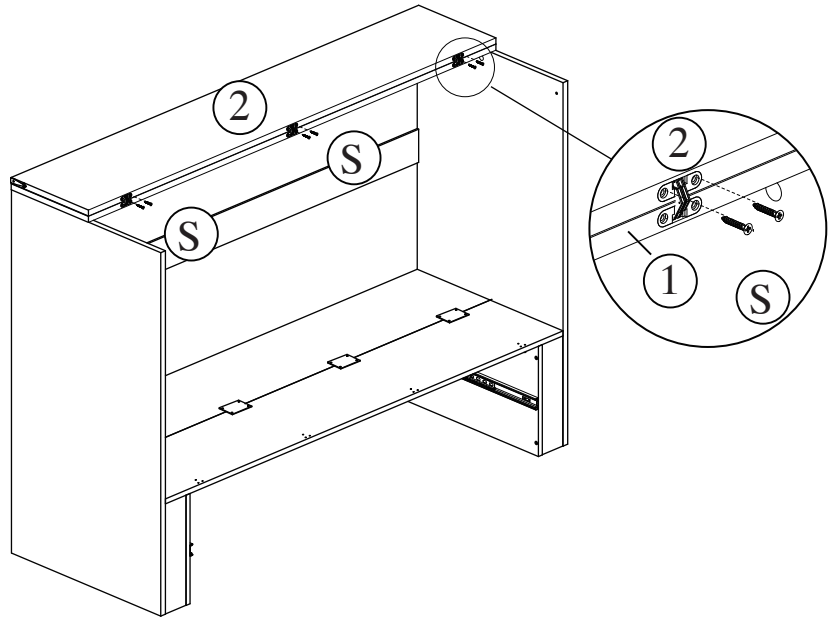
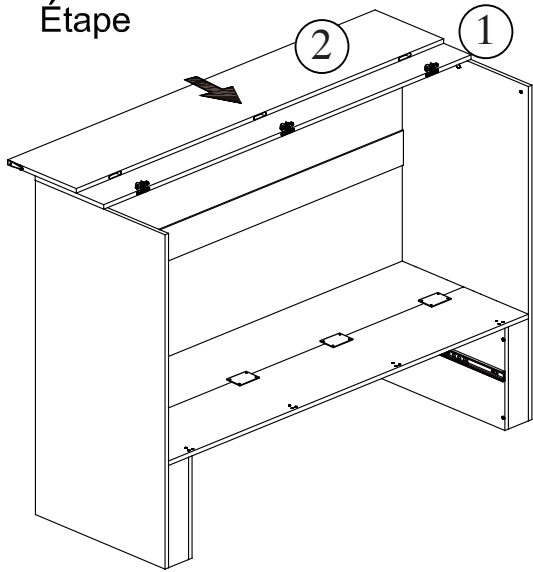

Étape

(S)	 3*25mm	06
-----	--	----



STEP 21:

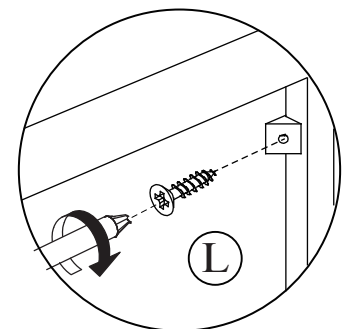
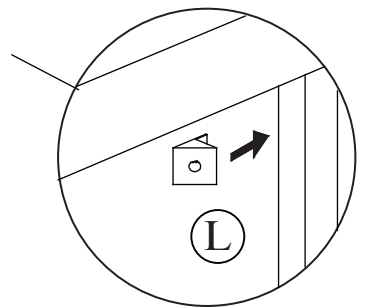
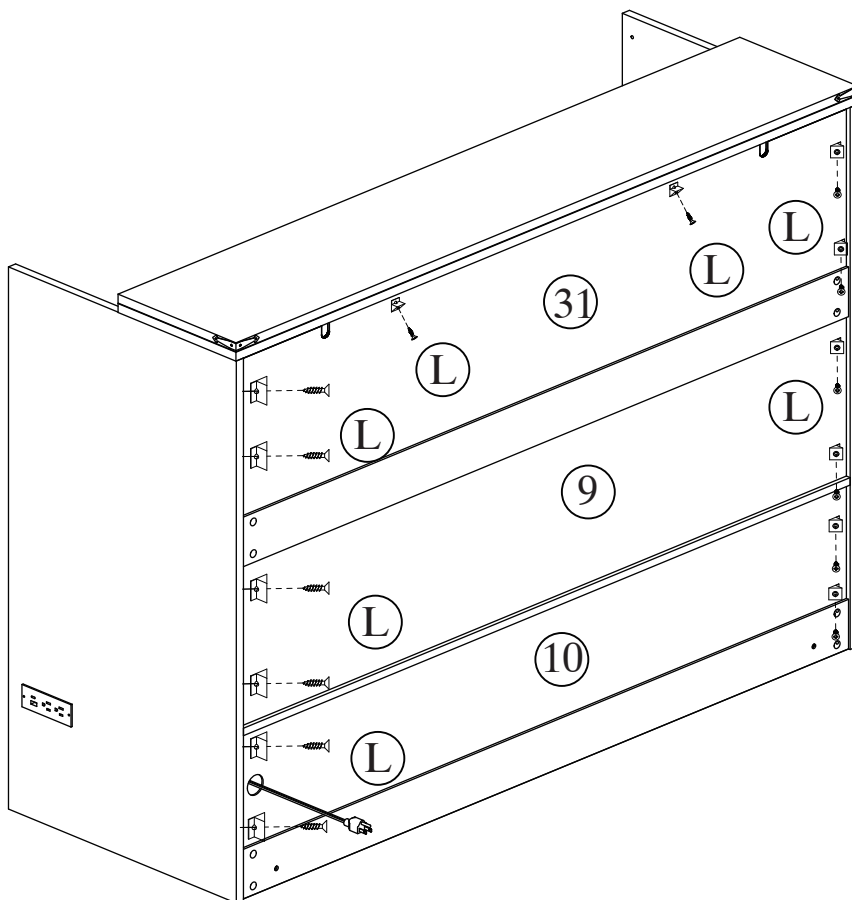

Étape

(L)	 	14
-----	---	----



STEP 22:

Étape

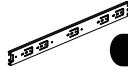

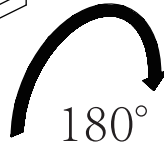
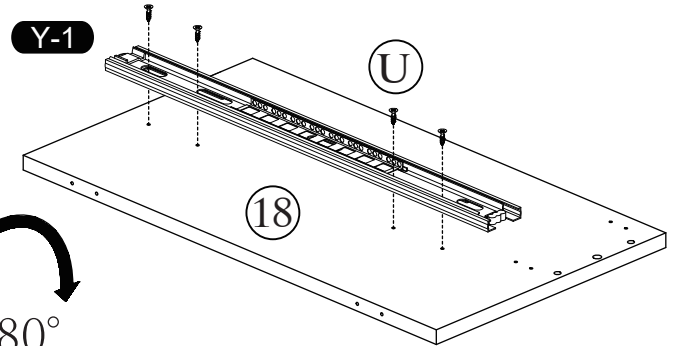
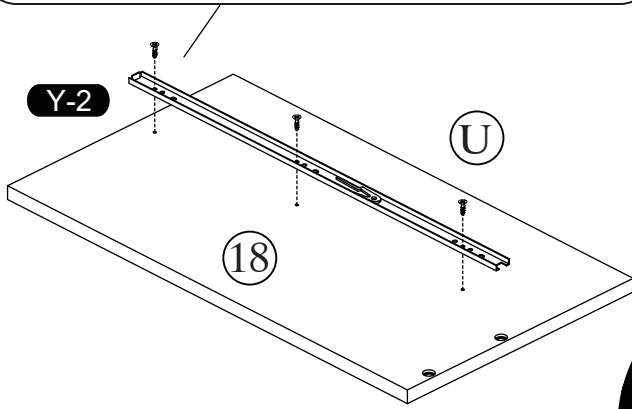
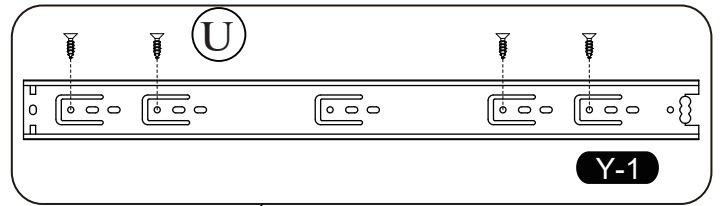
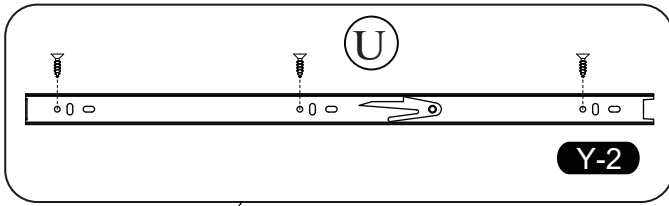
(Y)		Y-2	01	(U)		4*16mm	07
(Y)		Y-1	01				



Turn the panel over

STEP 23:

Étape

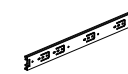
(Y)		Y-2	01	(U)		4*16mm	07
(Y)		Y-1	01				

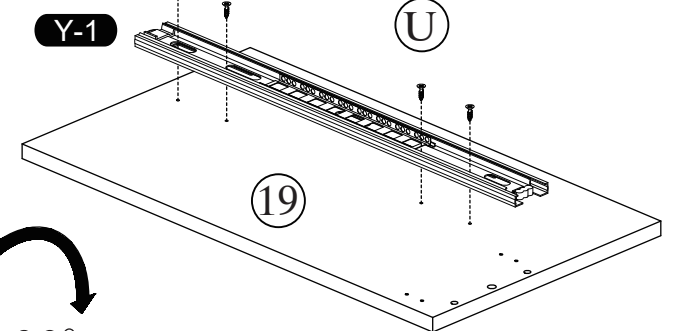
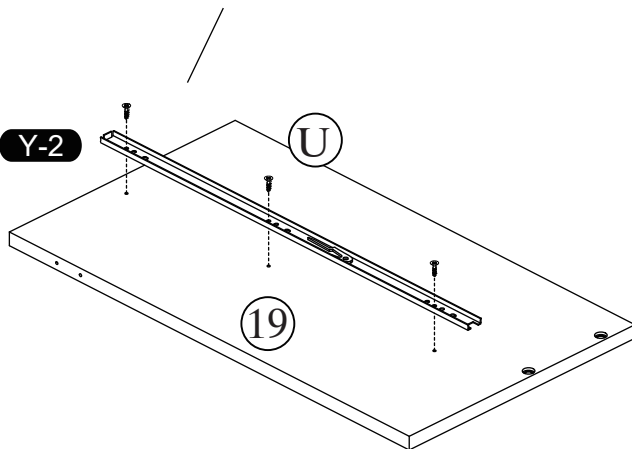
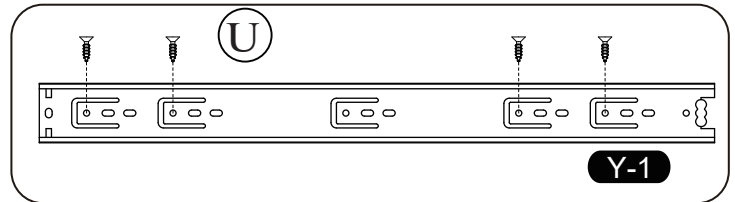
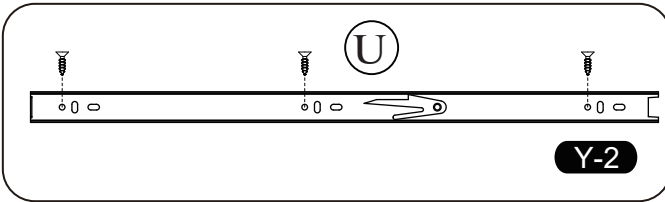

Turn the panel over

STEP 24:

Étape

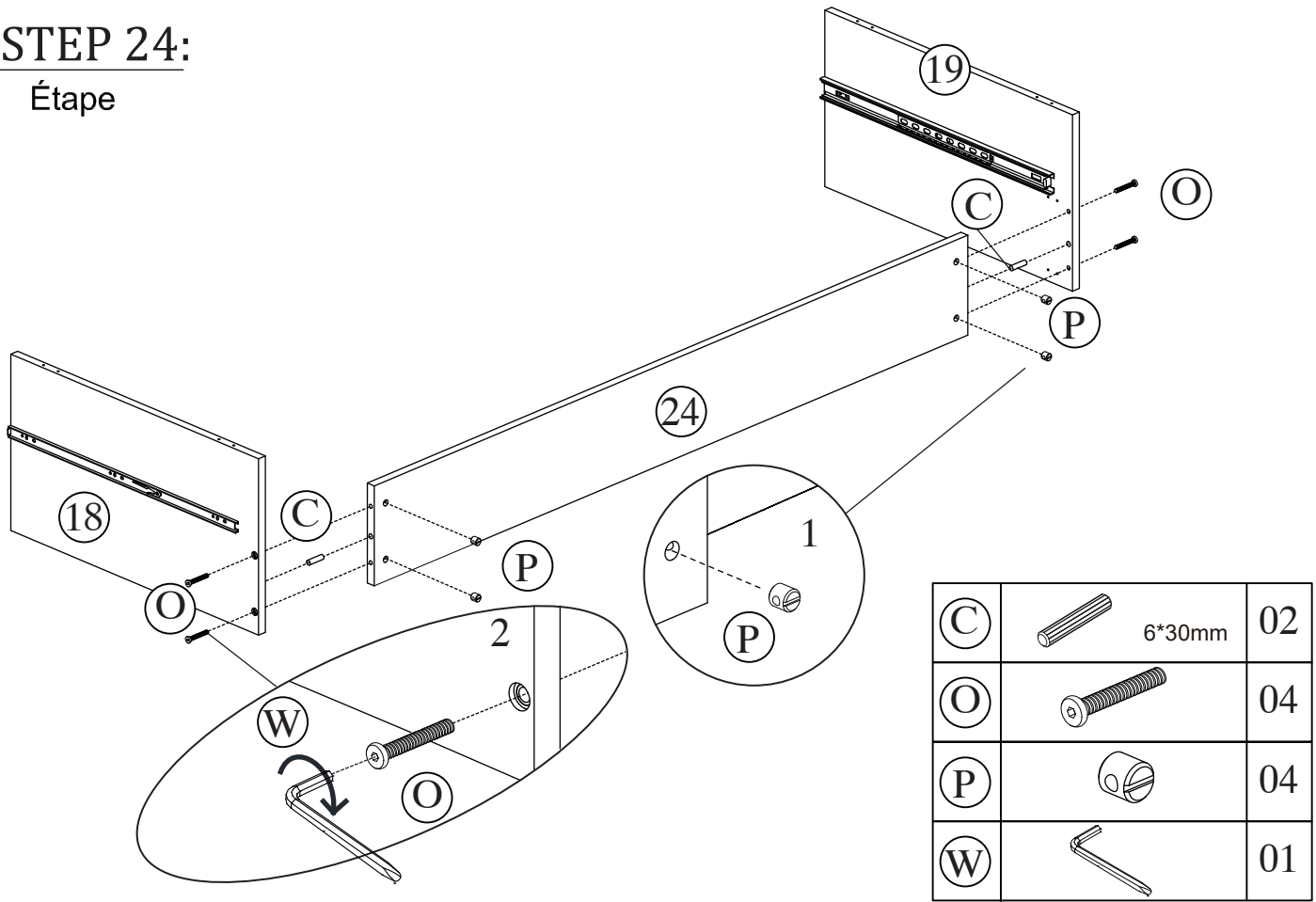

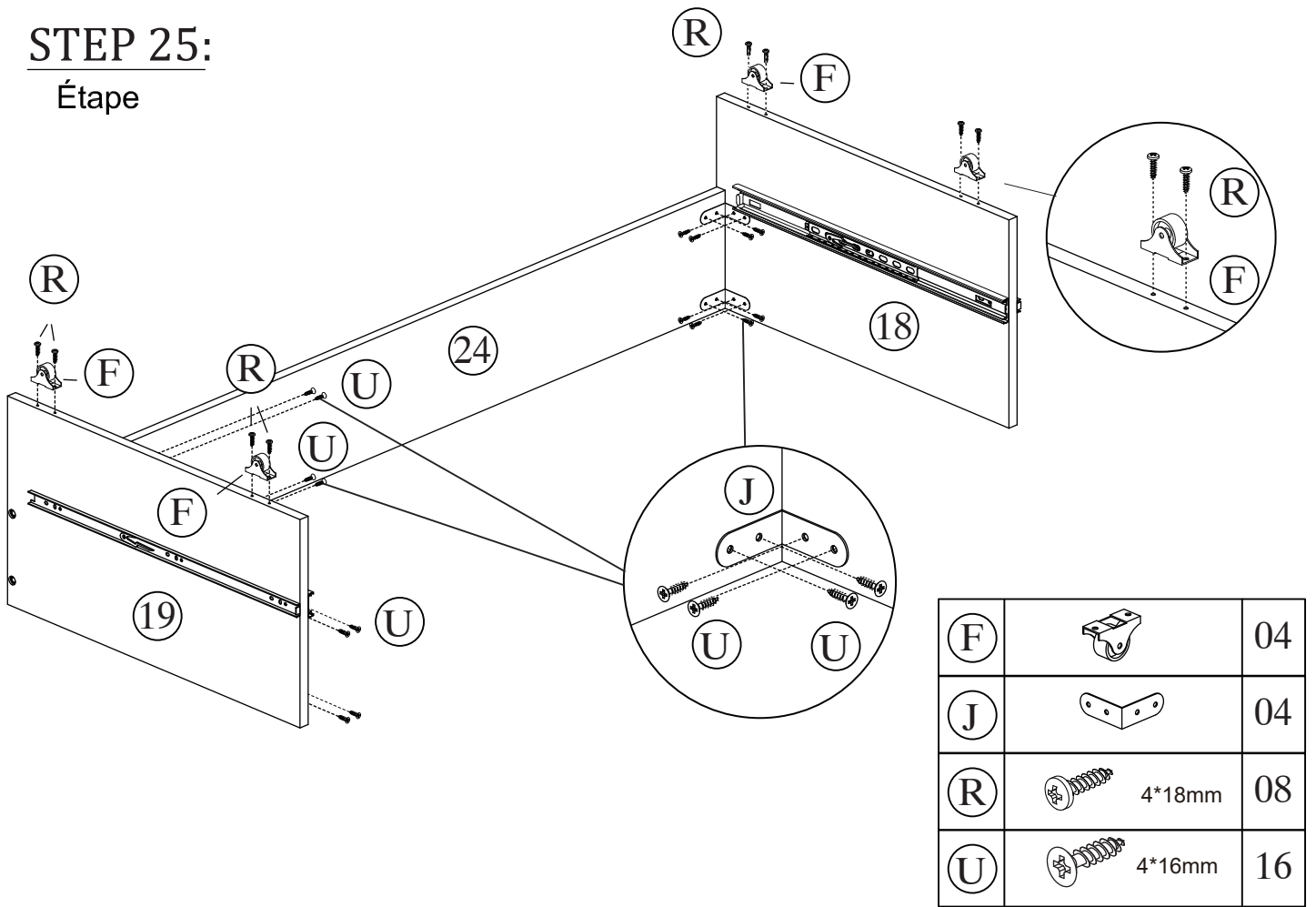

STEP 25:

Étape



STEP 26:

Étape

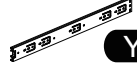
(Y)		Y-2	01	(U)		4*16mm	07
(Y)		Y-1		(U)			01

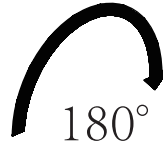
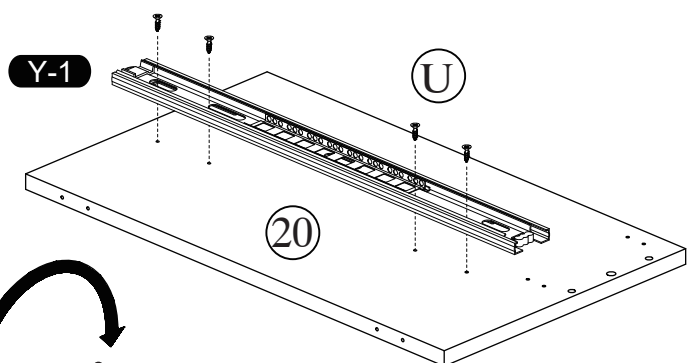
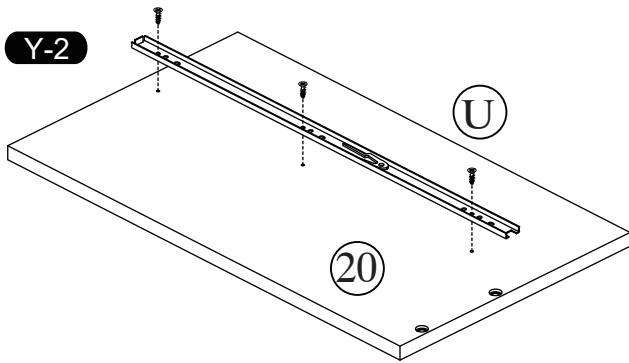
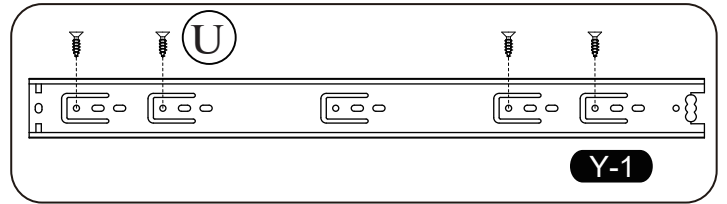
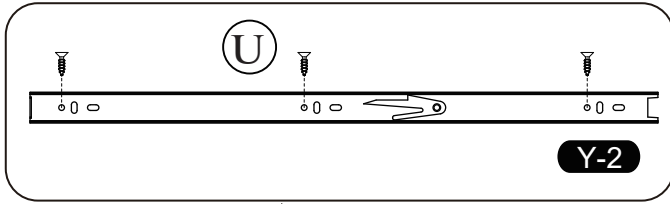

Turn the panel over

STEP 27:

Étape

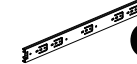
(Y)		Y-2	01	(U)		4*16mm	07
(Y)		Y-1		(U)			01

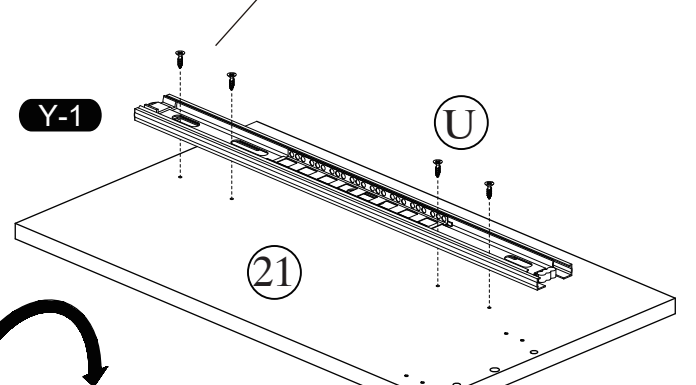
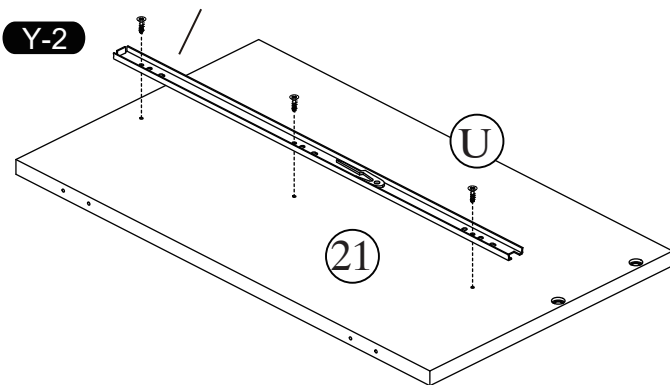
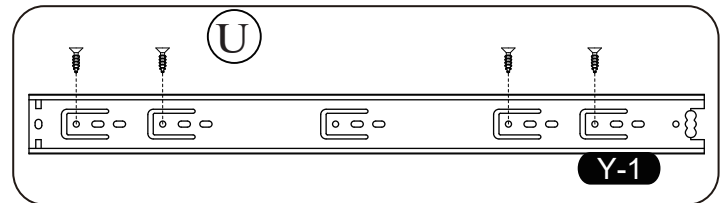
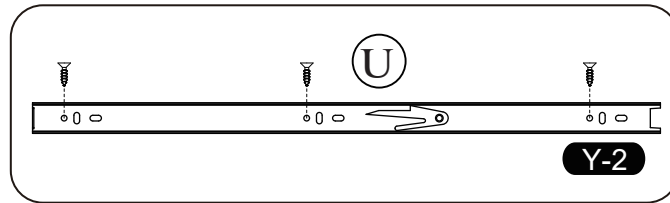



Turn the panel over

STEP 28:

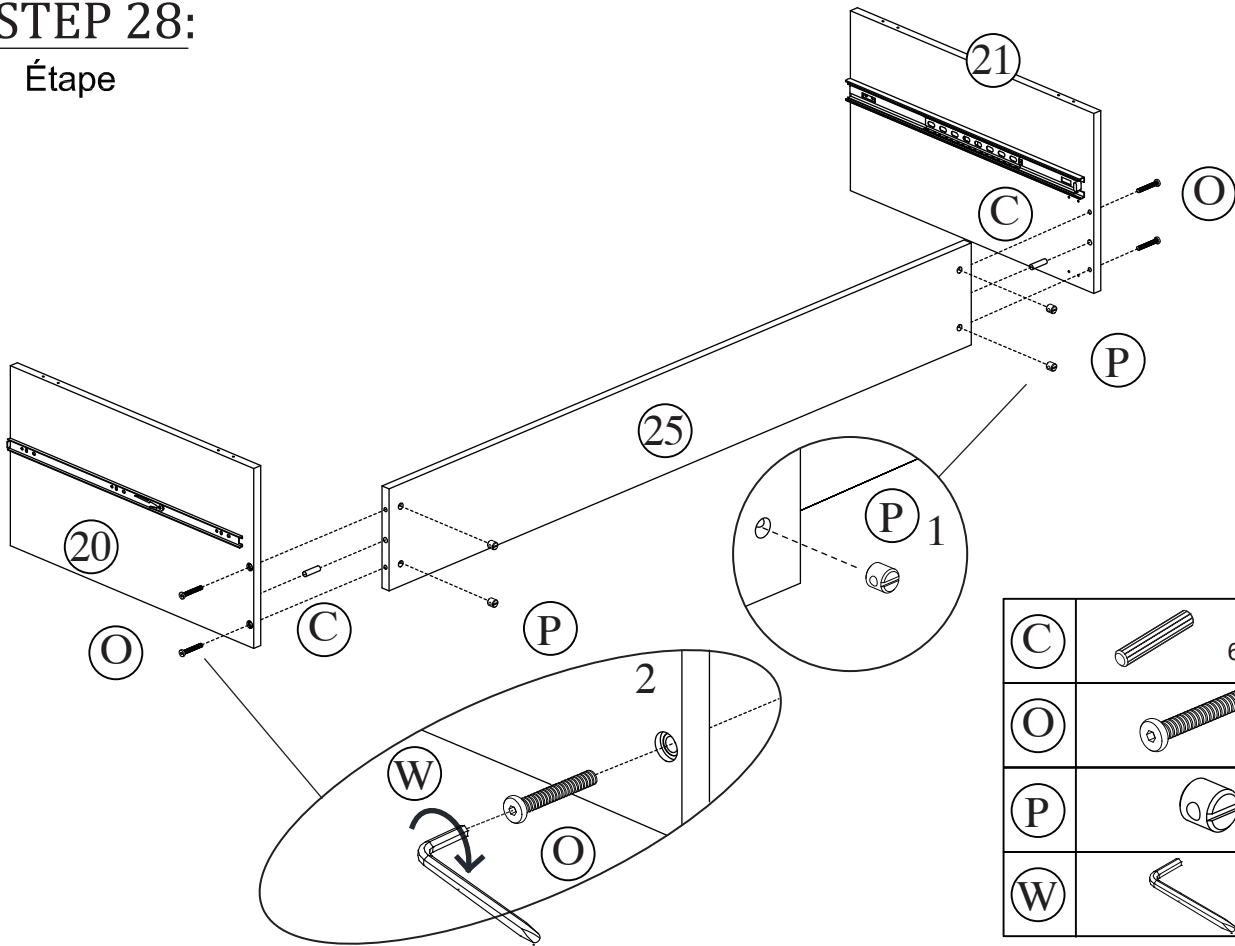
Étape

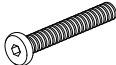



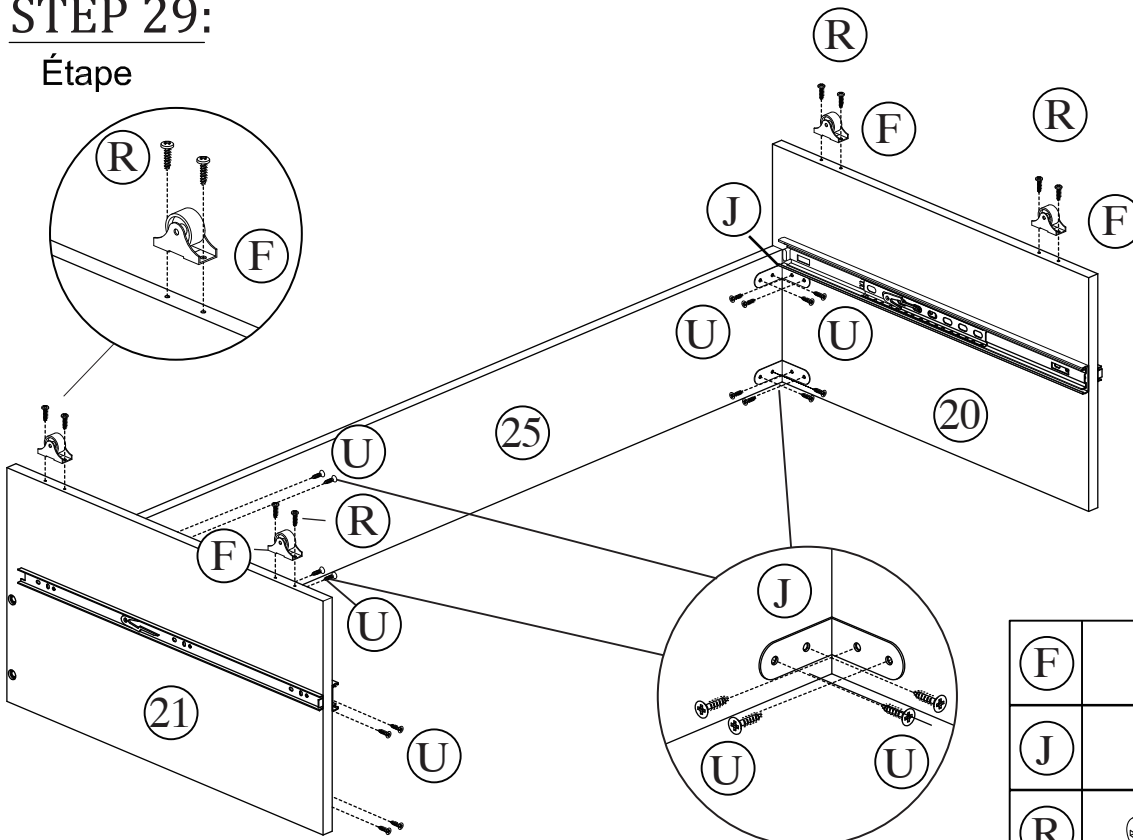

C		6*30mm	02
O			04
P			04
W			

STEP 29:



Étape



F			04
J			04
R		4*18mm	08
U		4*16mm	16

STEP 30:

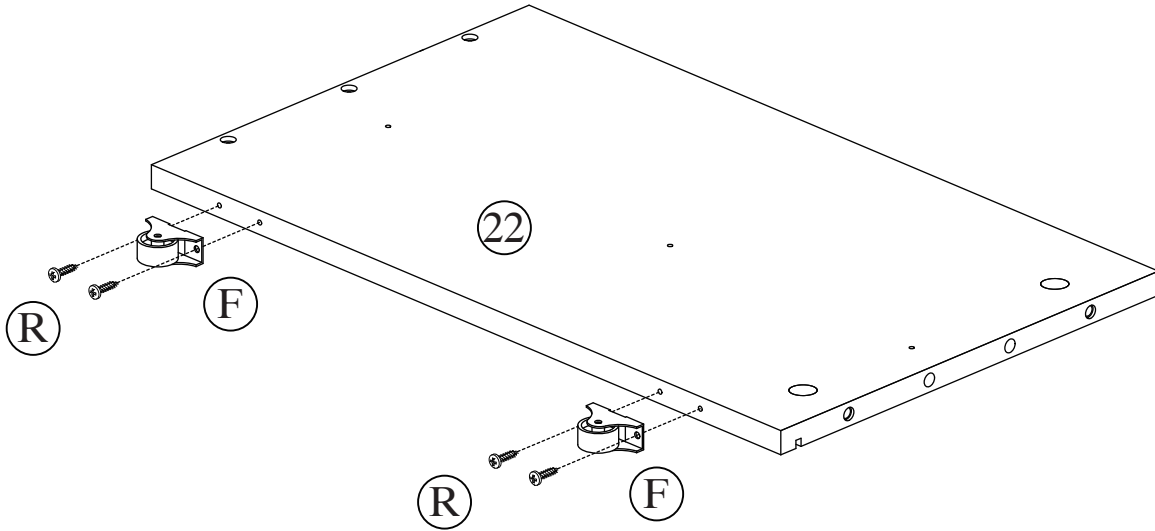

Étape

(F)		02
(R)	 4*18mm	04



STEP 31:

Étape

(F)		02
(R)	 4*18mm	04

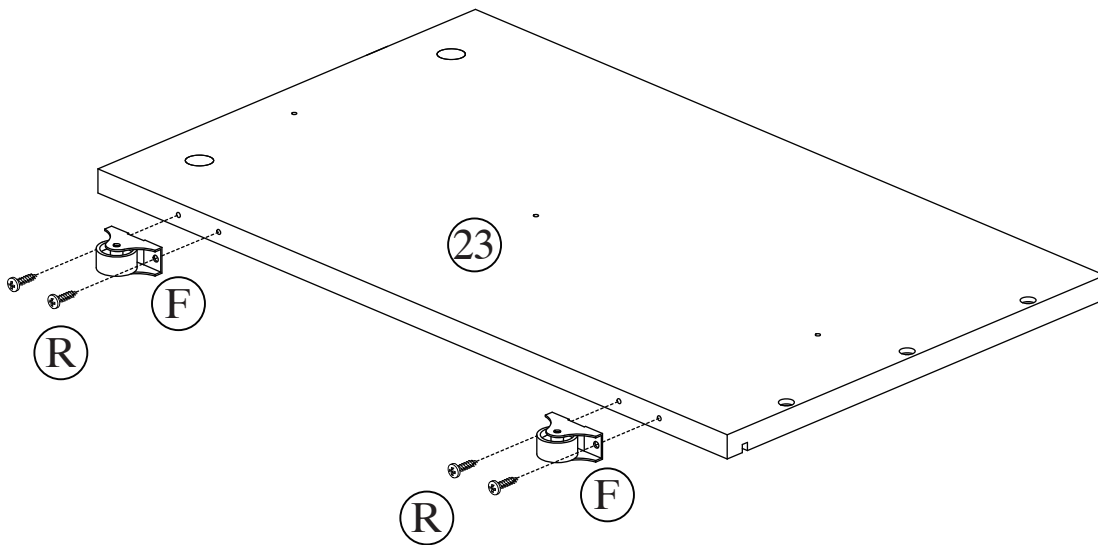

STEP 32:

Étape

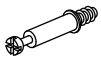
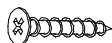
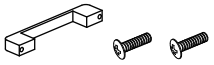
(A)		06
(N)	 4*25mm	07
(X)		02

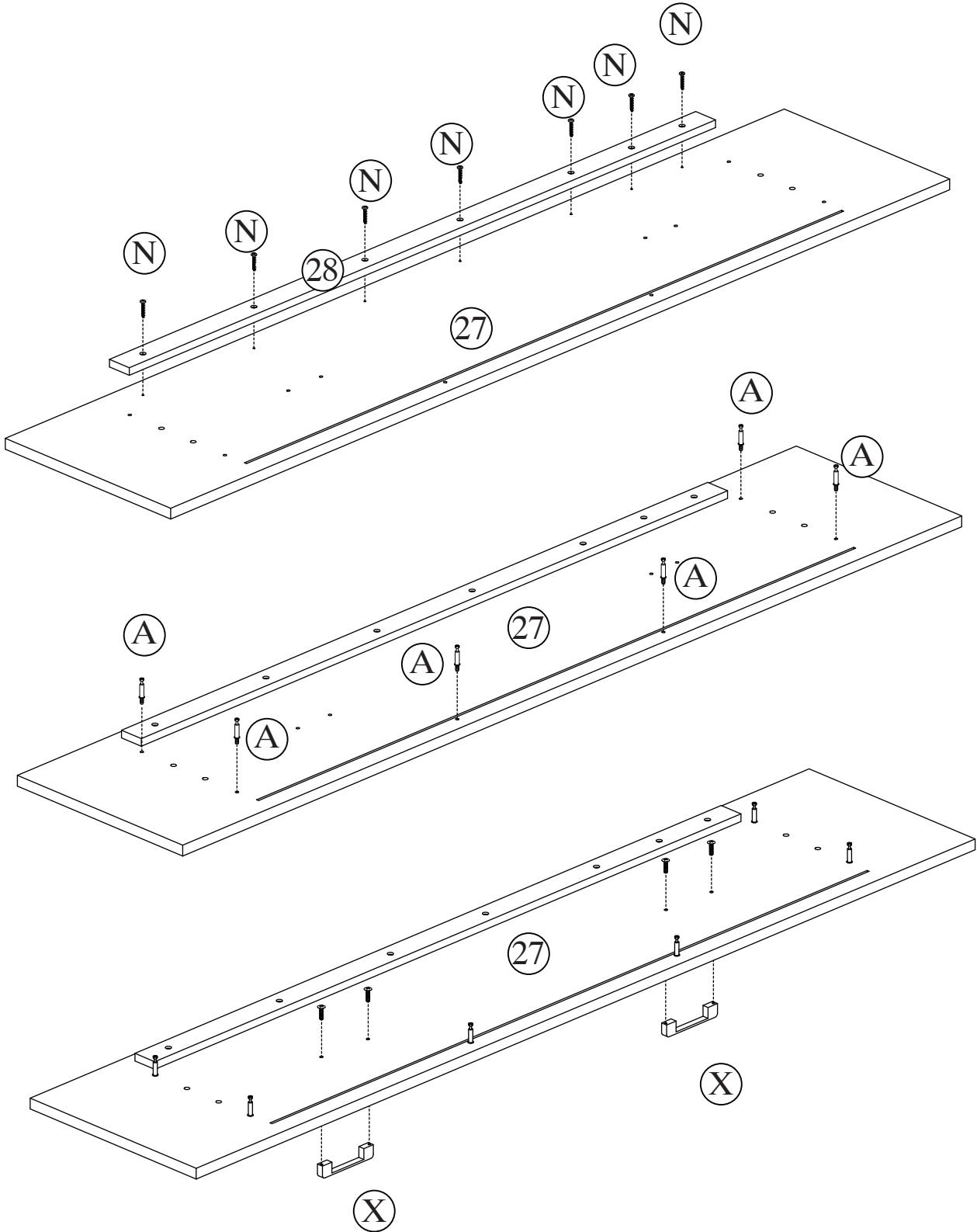

STEP 33:

Étape

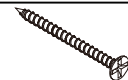
Q		4*40mm	06
---	--	--------	----

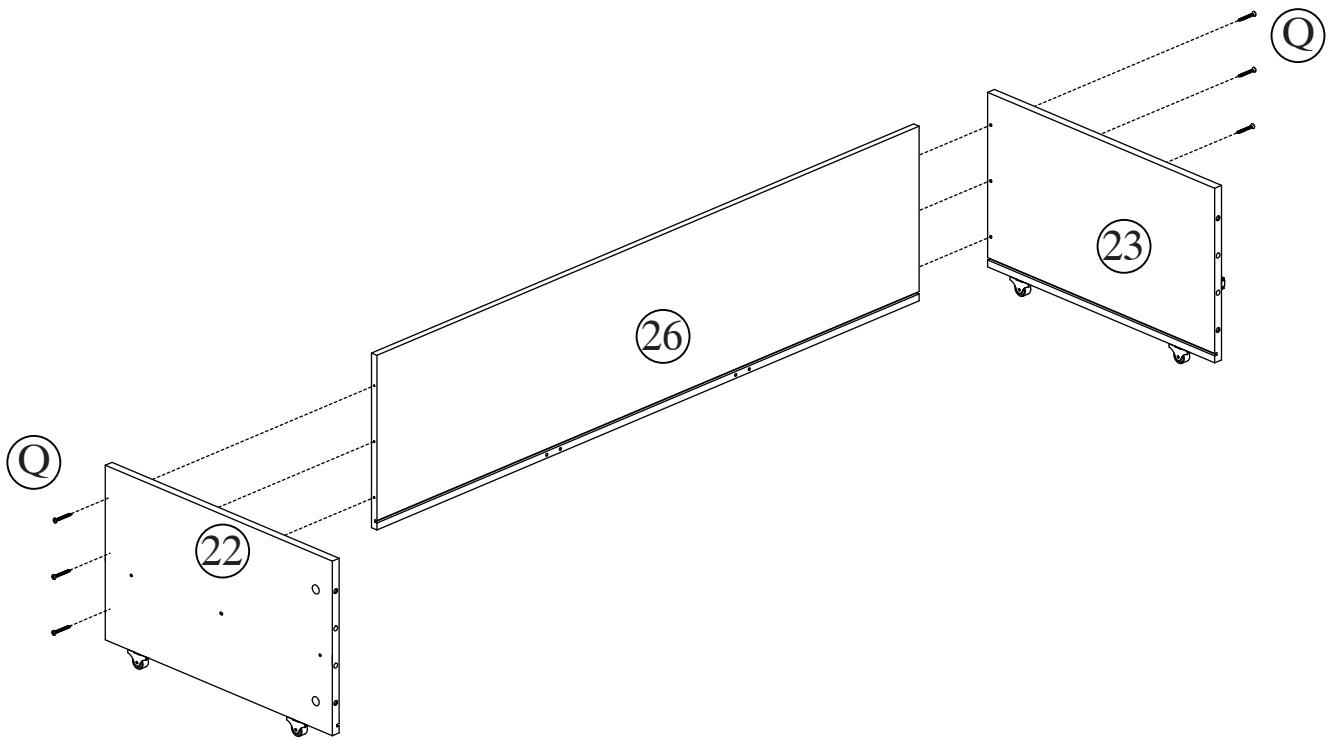

STEP 34:

Étape

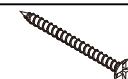
Q		4*40mm	04
---	---	--------	----

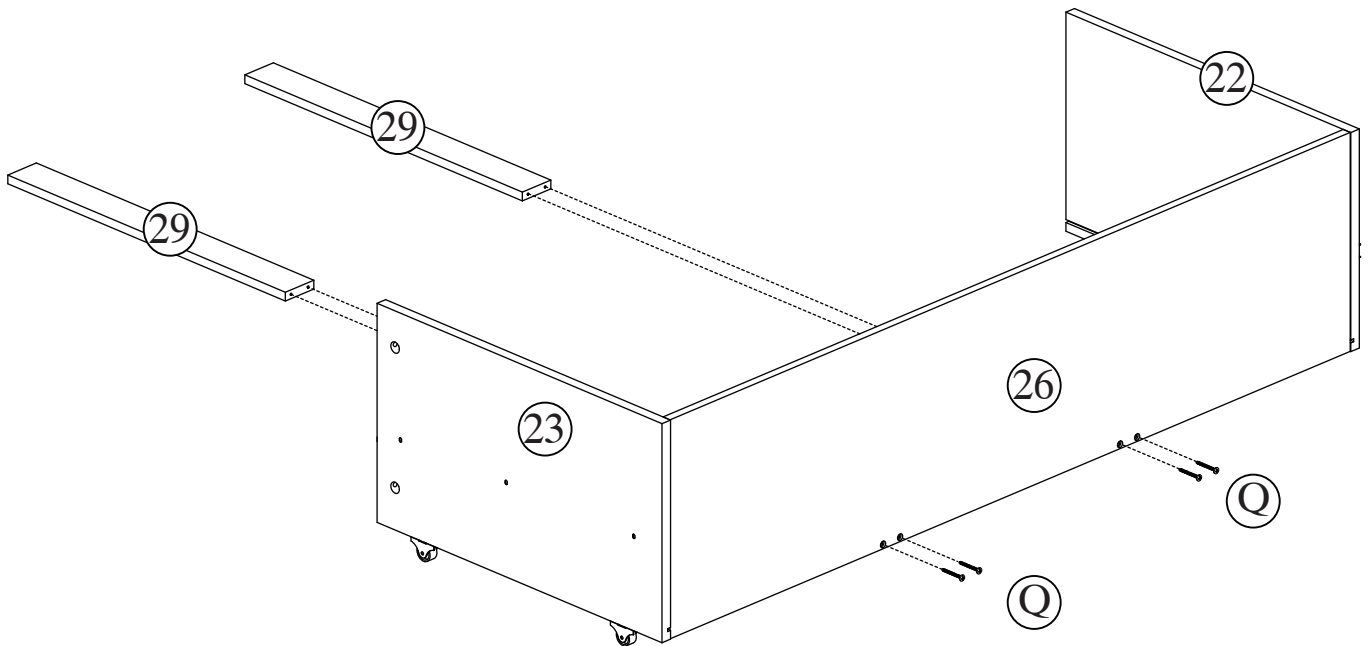

STEP 35:

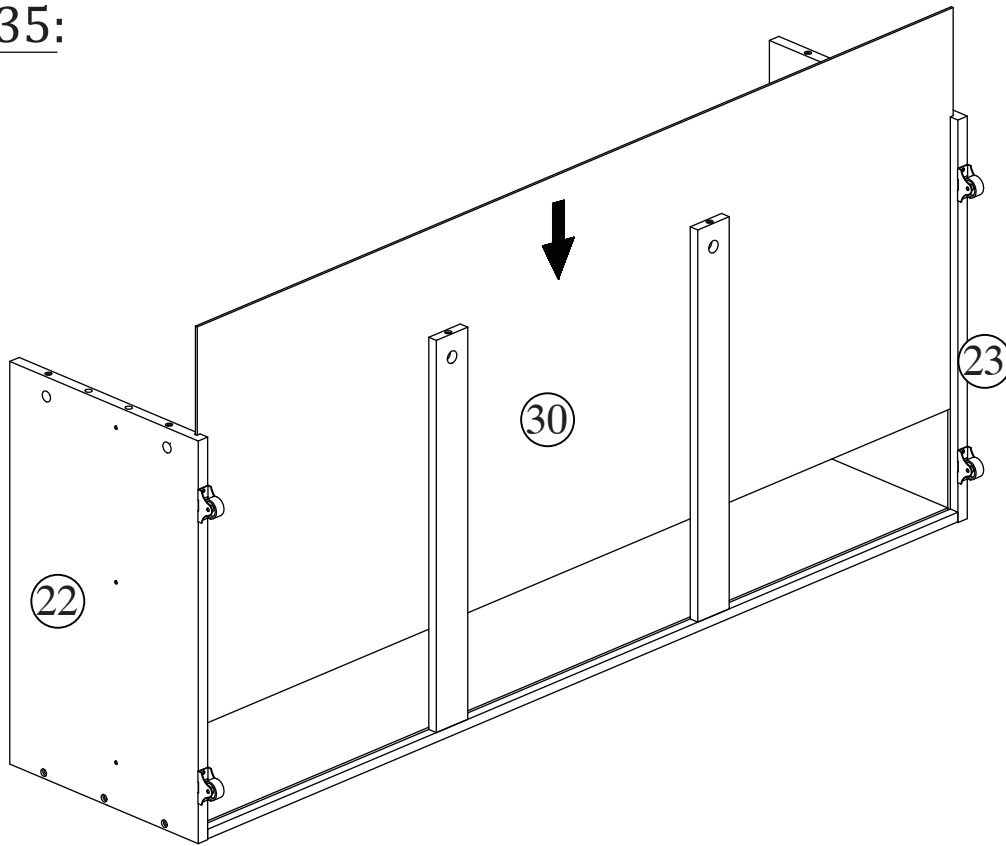

Étape

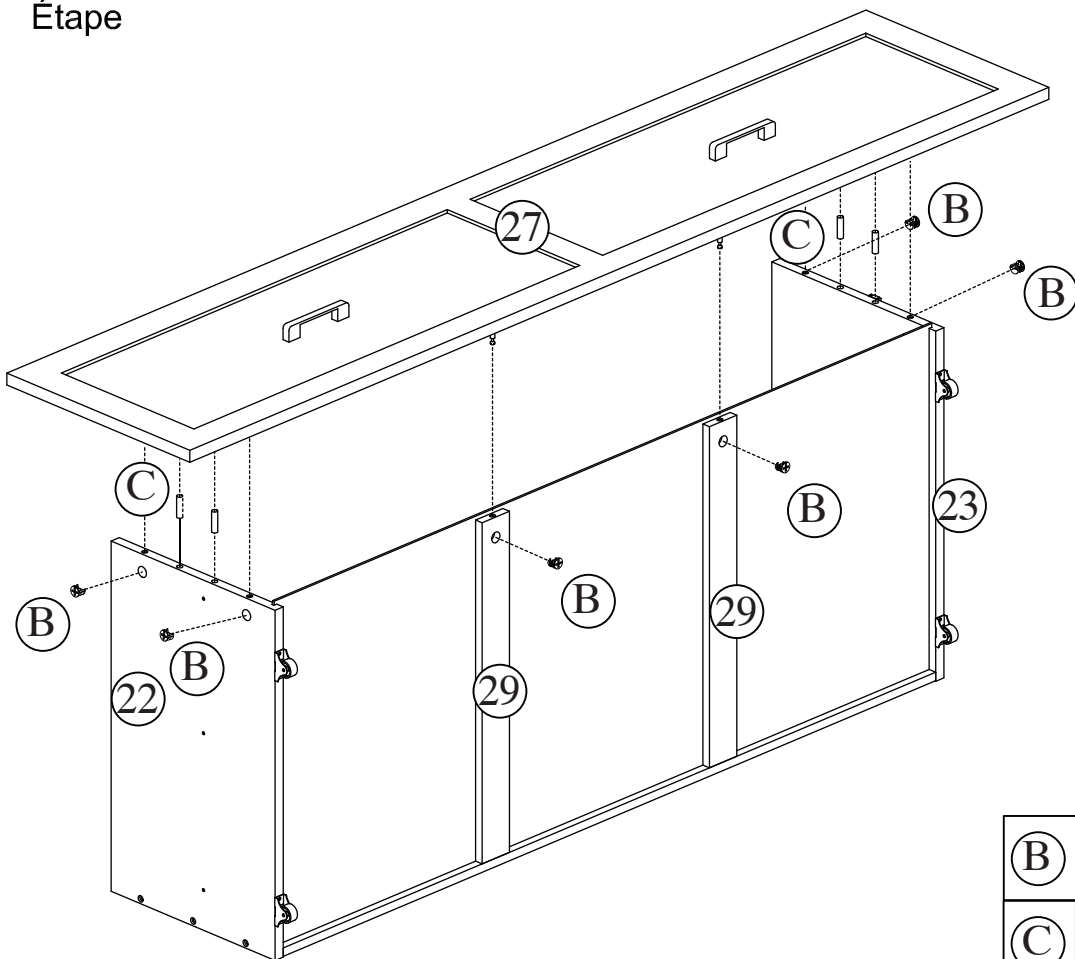

STEP 36:

Étape





(B)		06
(C)	 6*30mm	04

STEP 37:

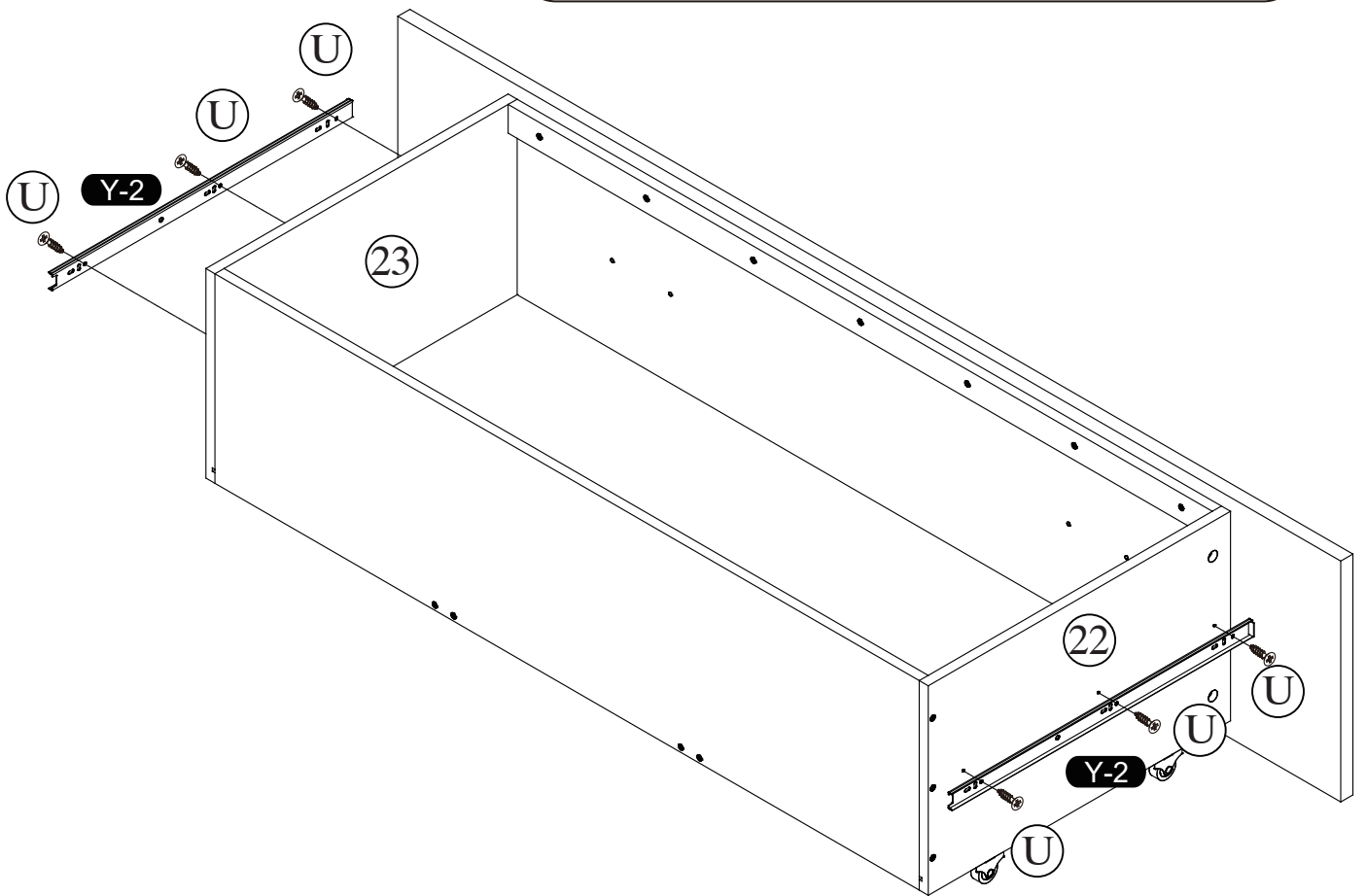
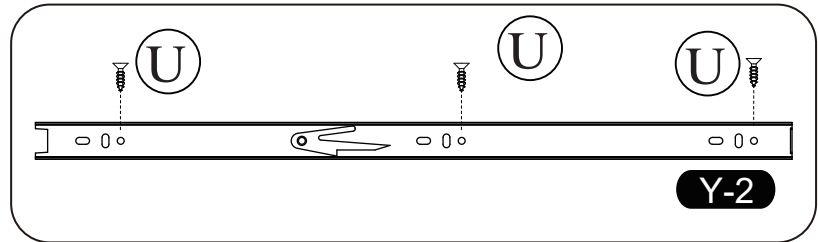
Étape



U	 4*16mm	06
Y	 Y-2	02

STEP 38:

Étape

Please make sure that the balls in the tracks on both sides are pulled to the top, and then insert the tracks to ensure smooth entry.

Veuillez vous assurer que les billes dans les rails des deux côtés sont tirées vers le haut, puis insérez les rails pour garantir une entrée sans heurt.

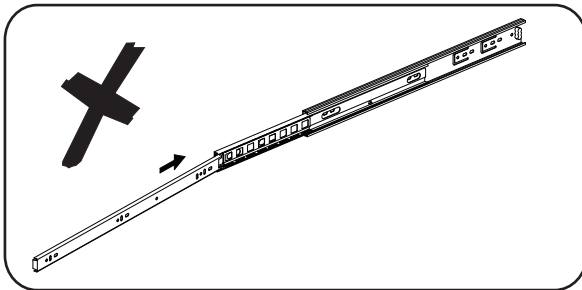
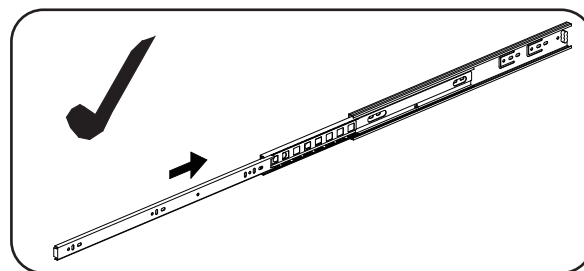
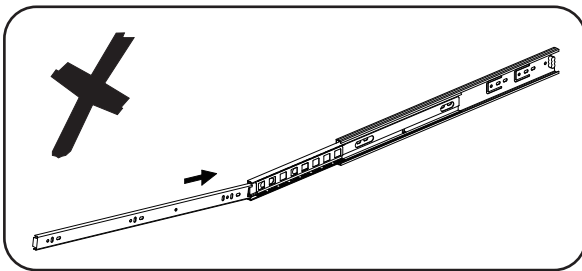
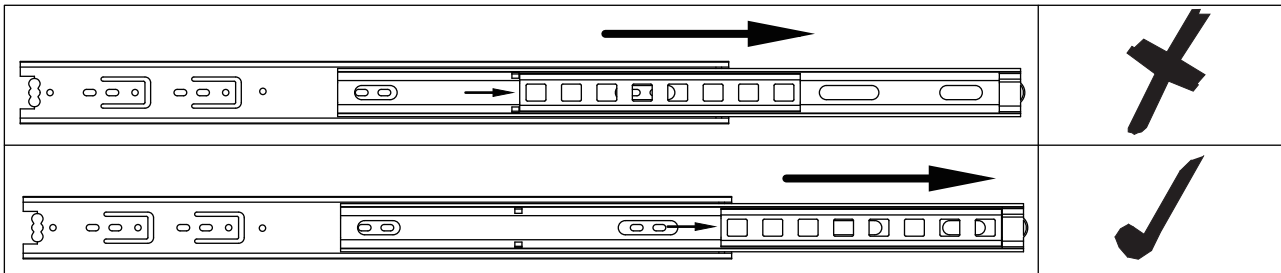

1. Drawers must be horizontally put into the cabinets.
2. Make sure both sides sliders match well to avoid damage.

1. Les tiroirs doivent être horizontalement mis dans les armoires.
2. Assurez-vous que les curseurs des deux côtés s'assortissent bien pour éviter les dommages.

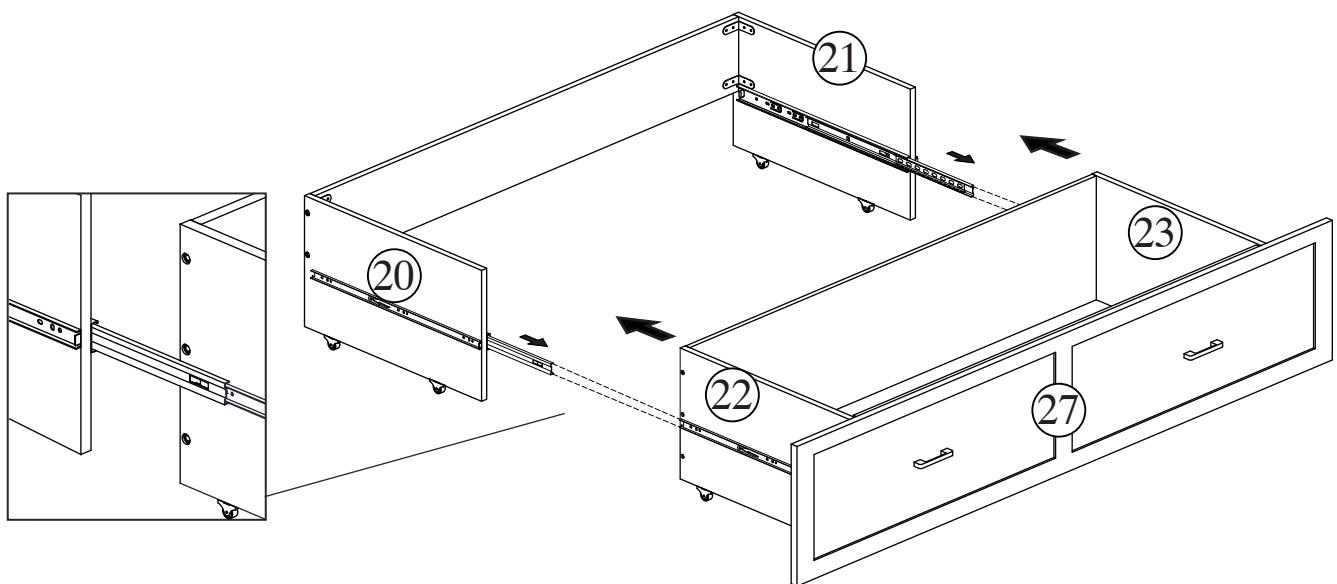

Try to find a partner to install with you.

Essayez de trouver un partenaire à installer avec vous.

STEP 39:

Étape

Please make sure that the balls in the tracks on both sides are pulled to the top, and then insert the tracks to ensure smooth entry.

Veillez vous assurer que les billes dans les rails des deux côtés sont tirées vers le haut, puis insérez les rails pour garantir une entrée sans heurt..

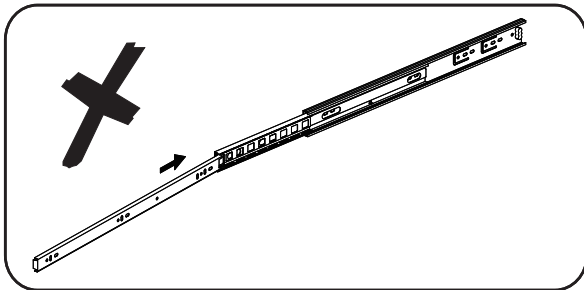
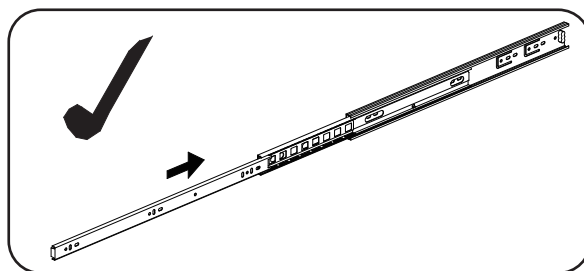
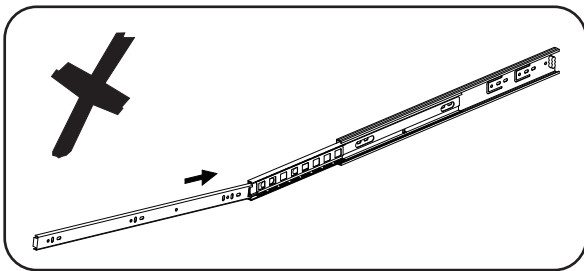
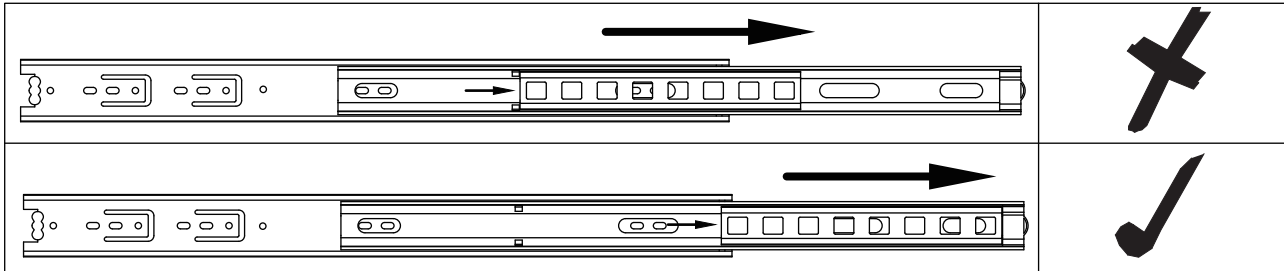

1. Drawers must be horizontally put into the cabinets.
2. Make sure both sides sliders match well to avoid damage.

1. Les tiroirs doivent être horizontalement mis dans les armoires.
2. Assurez-vous que les curseurs des deux côtés s'assortissent bien pour éviter les dommages.

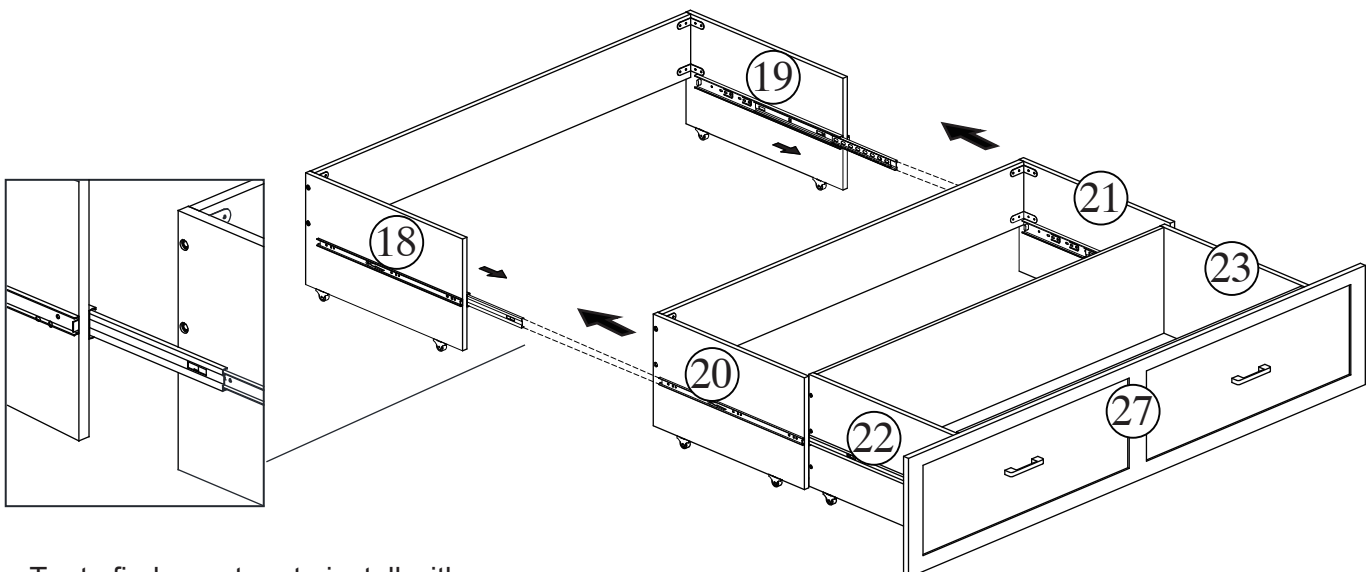

Try to find a partner to install with you.
Essayez de trouver un partenaire à installer avec vous.

STEP 41:

Étape

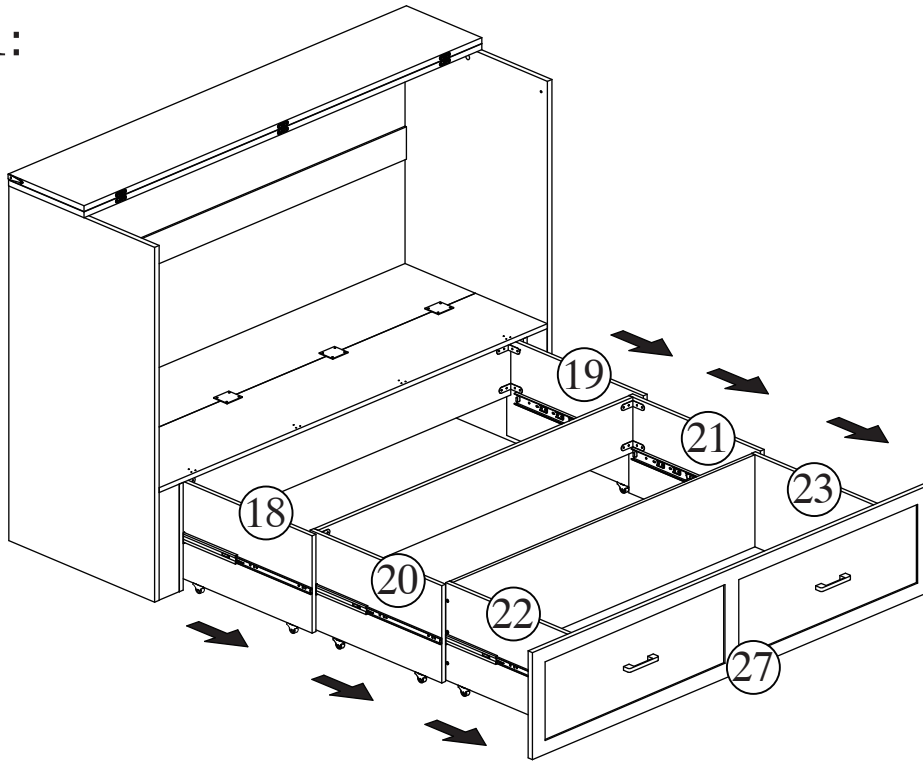

STEP 42:

Étape

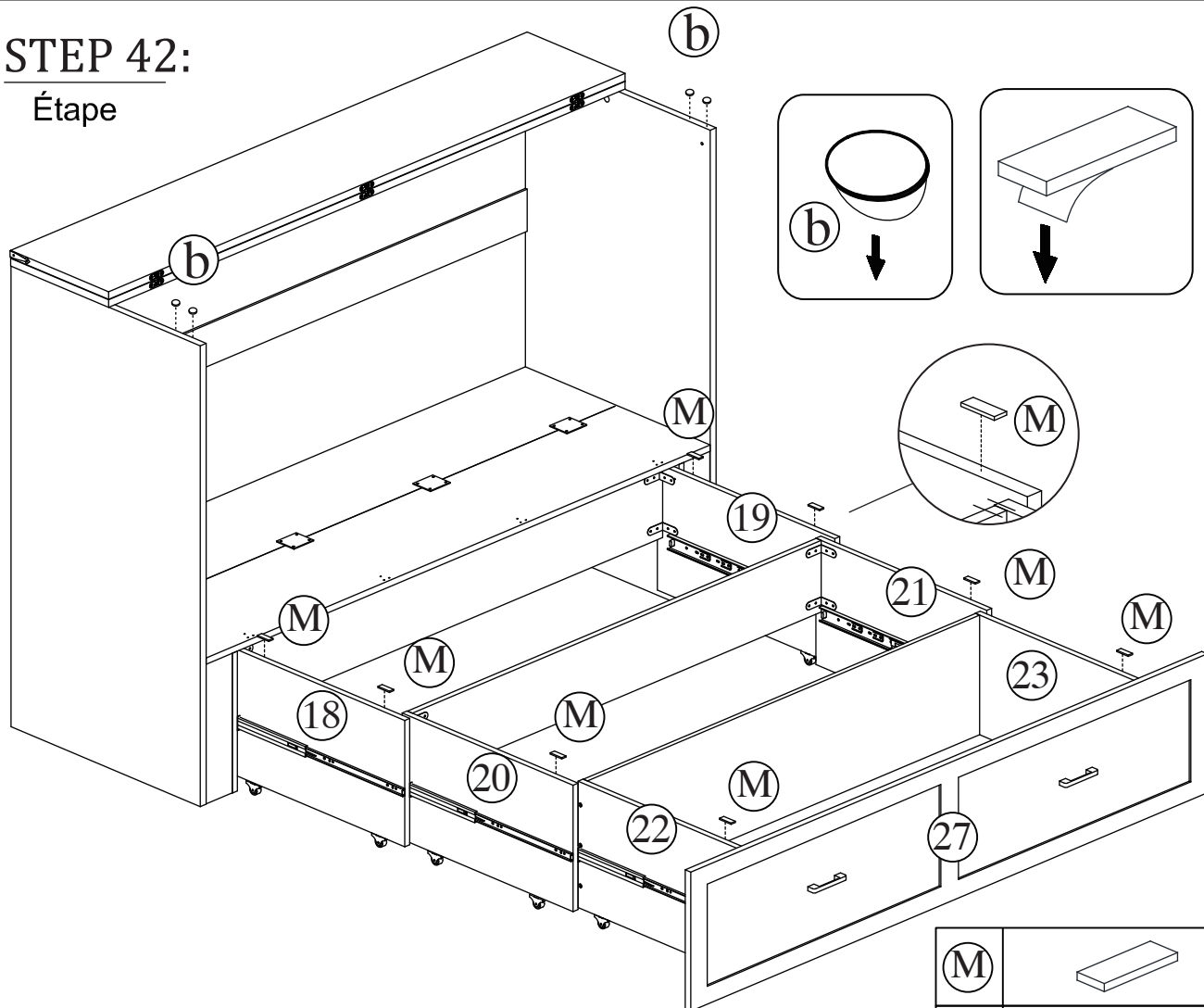

(M)		08
(b)		04

STEP 43:

Étape

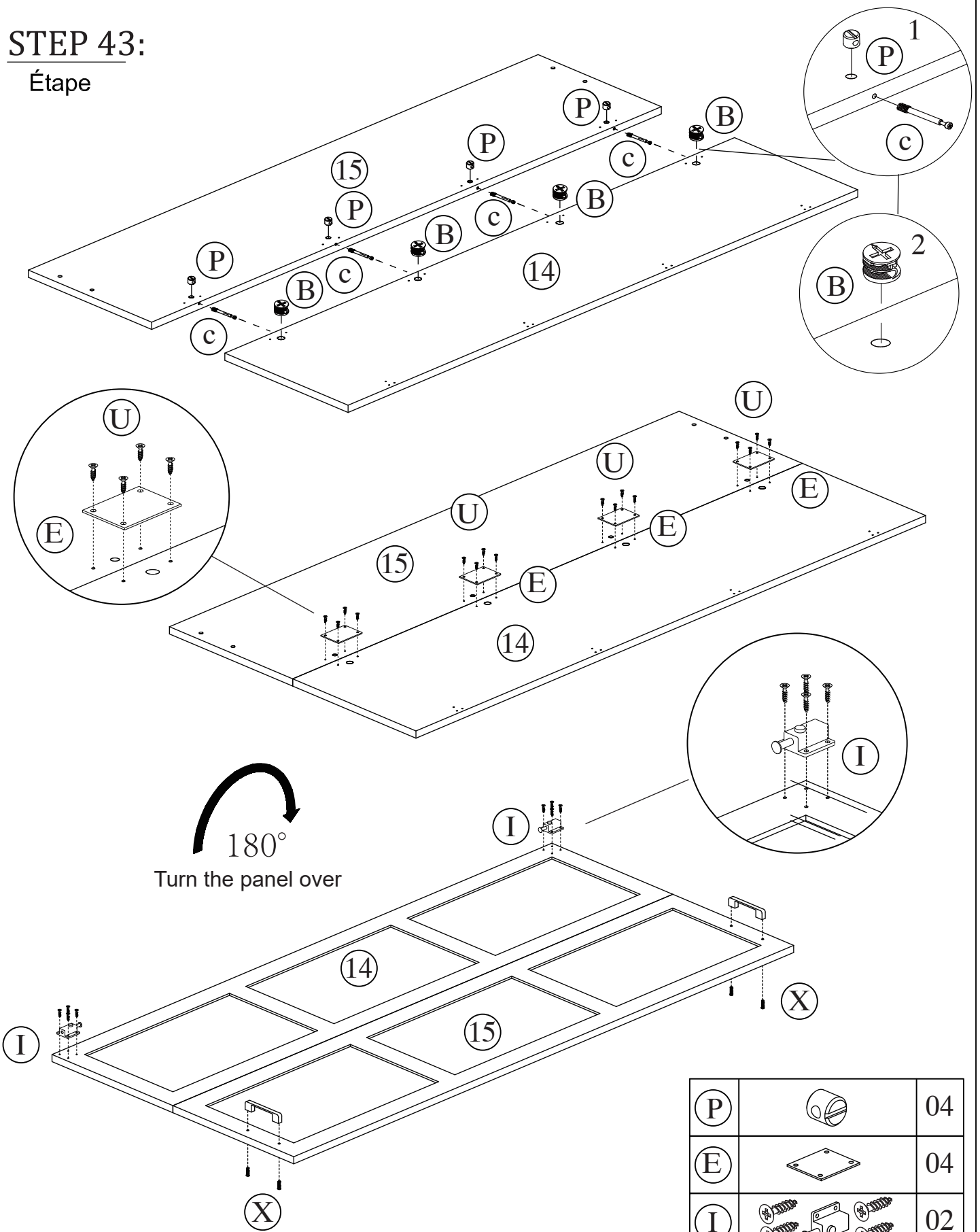

180°
Turn the panel over

(P)		04	(U)		16
(E)		04	(X)		02
(I)		02	(c)		04
(B)		04			

STEP 44:

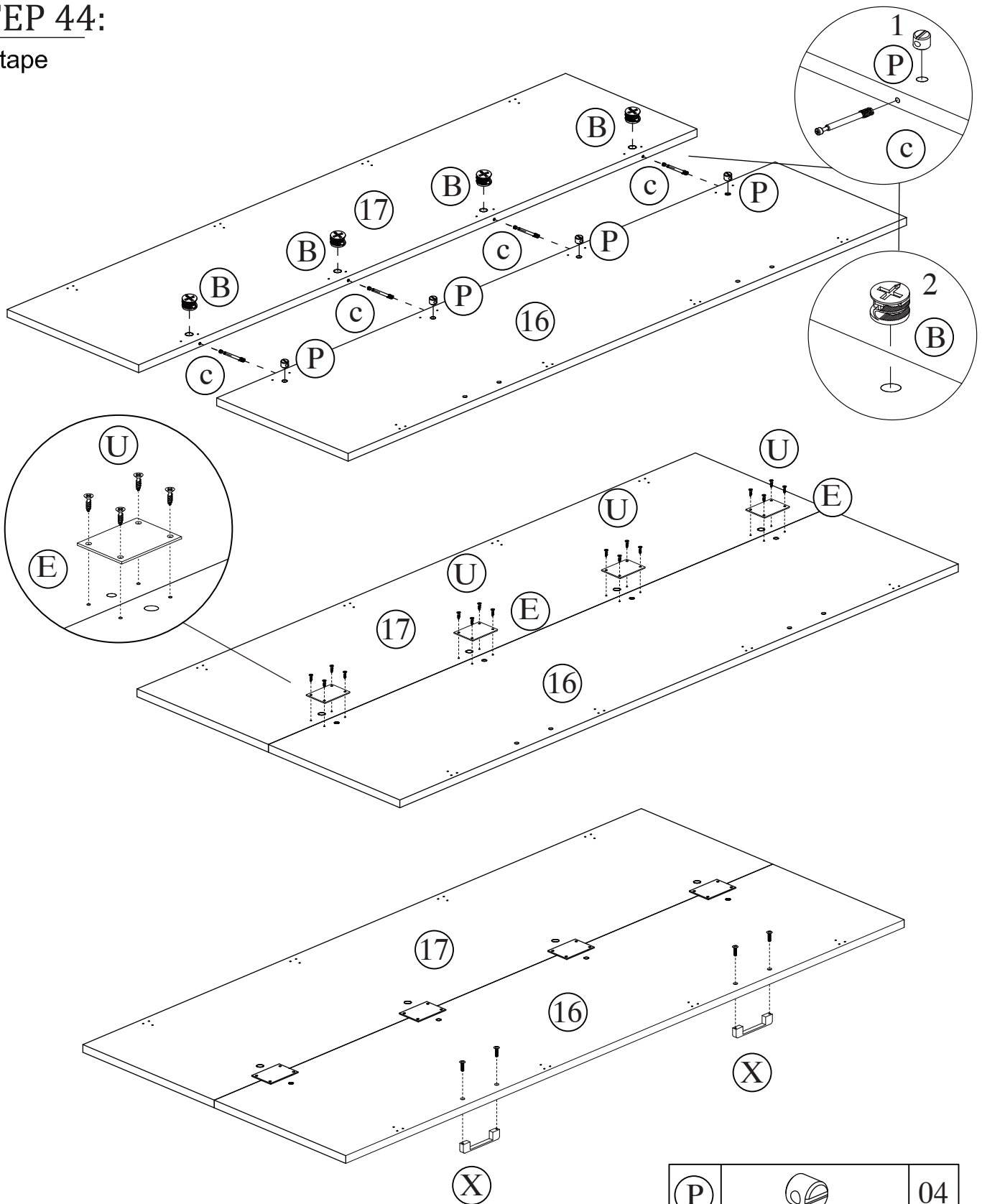

Étape



(P)		04
(E)		04
(c)		04
(B)		04
(U)		16
(X)		02

STEP 45:

Étape

G		08
U	 4*16mm	48

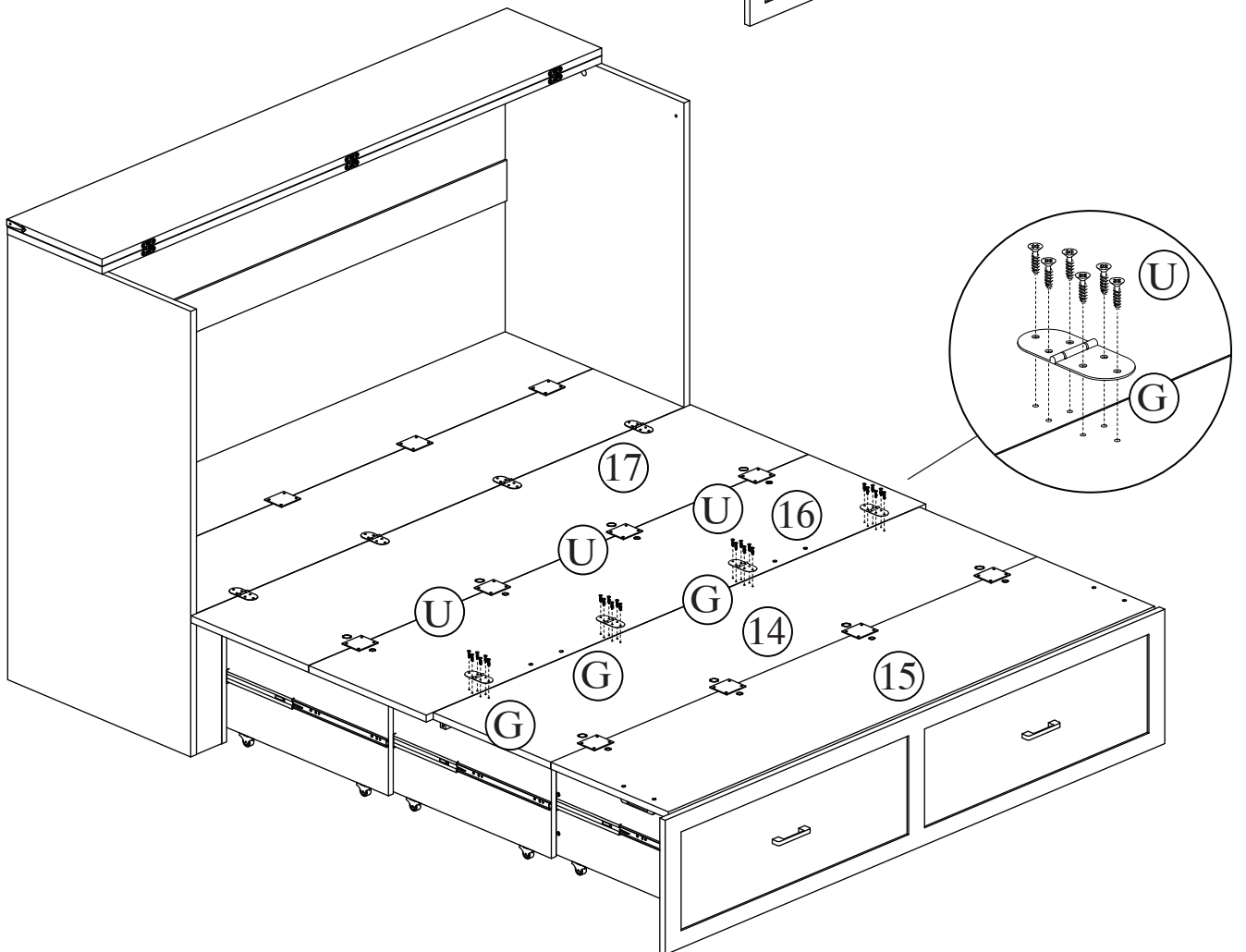
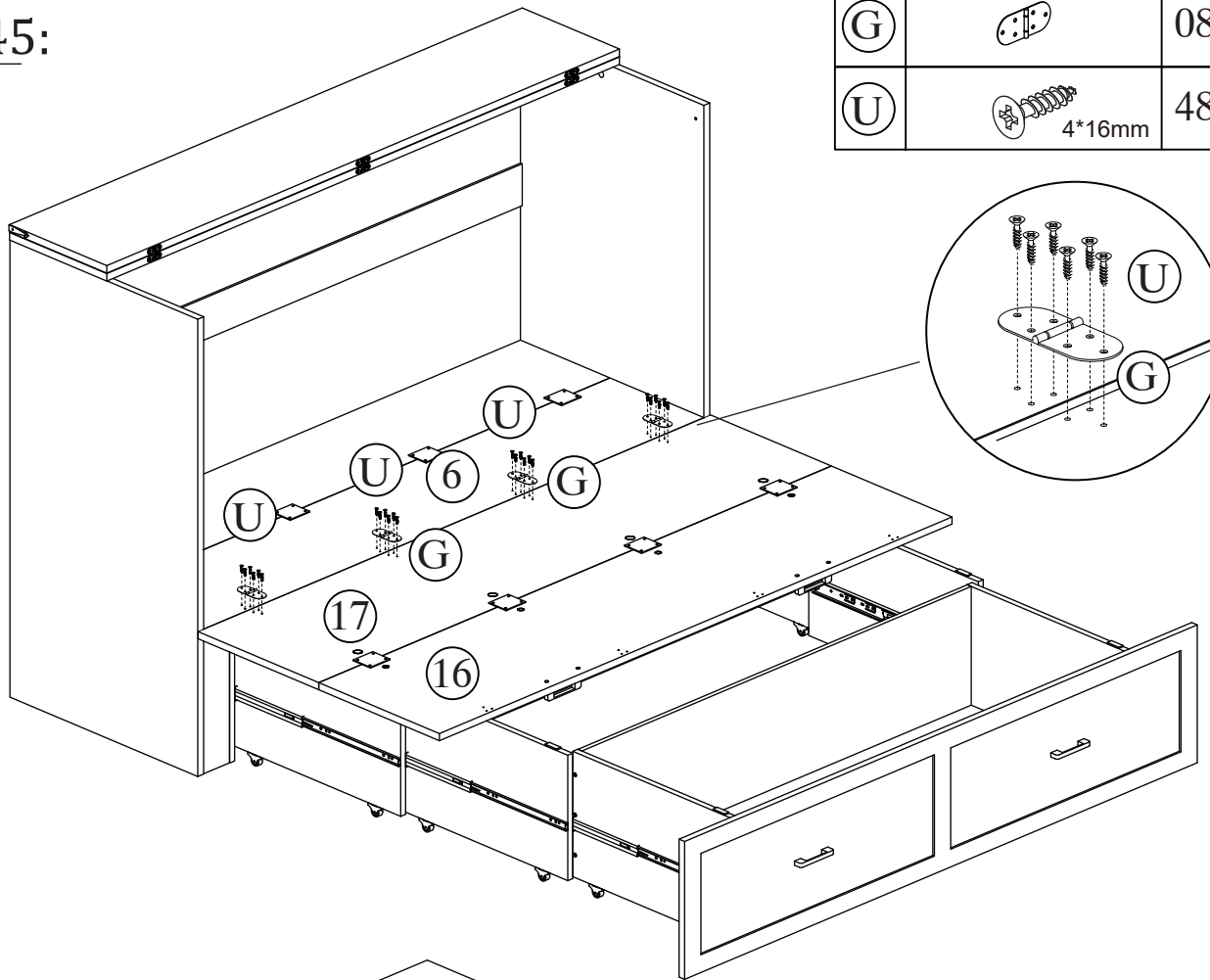

STEP 46:

Étape

a		04
---	--	----

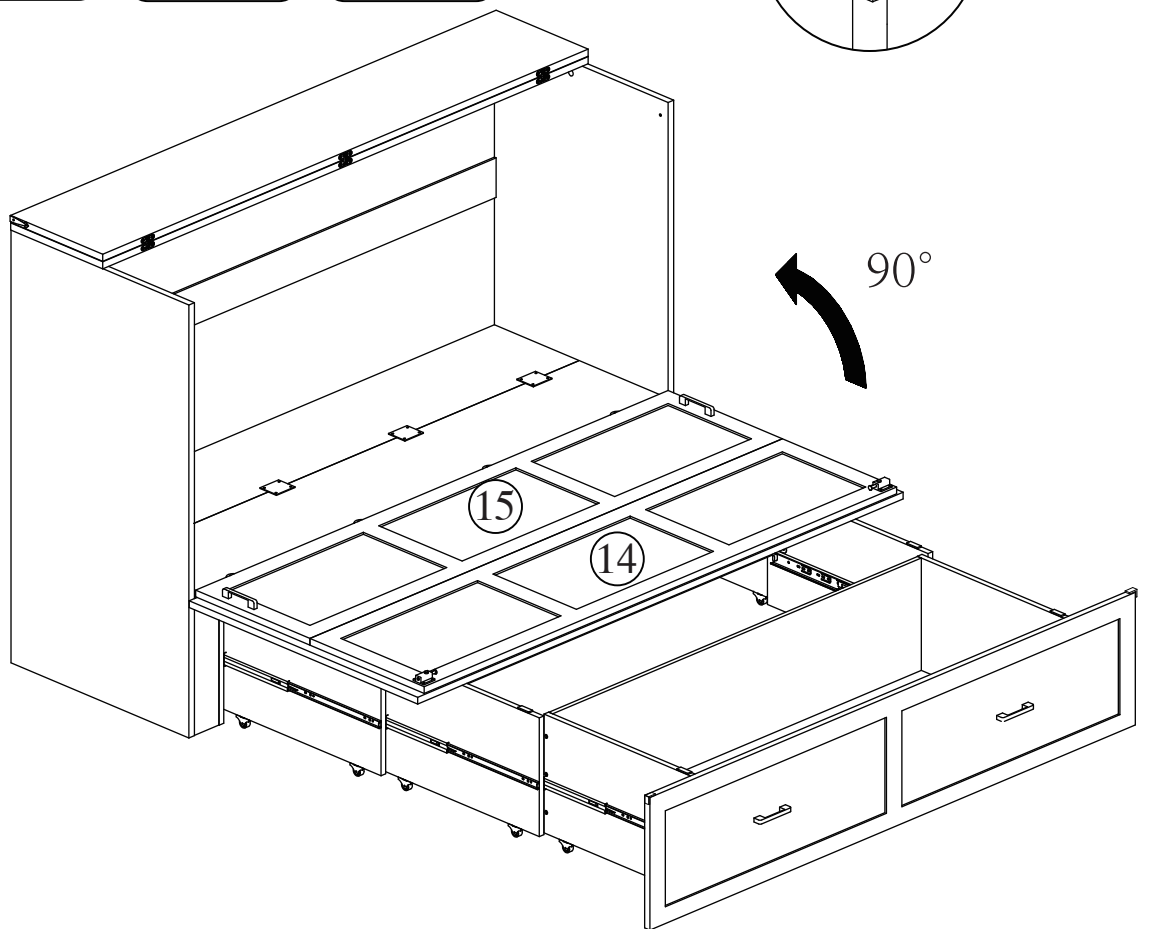
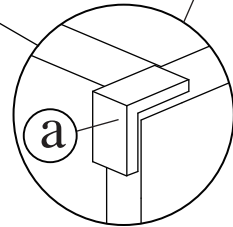
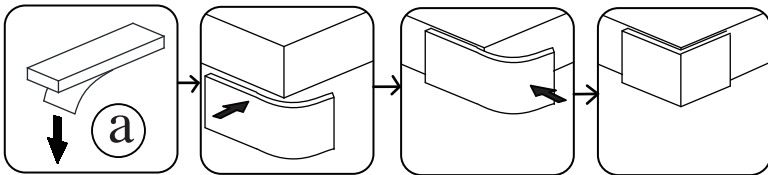
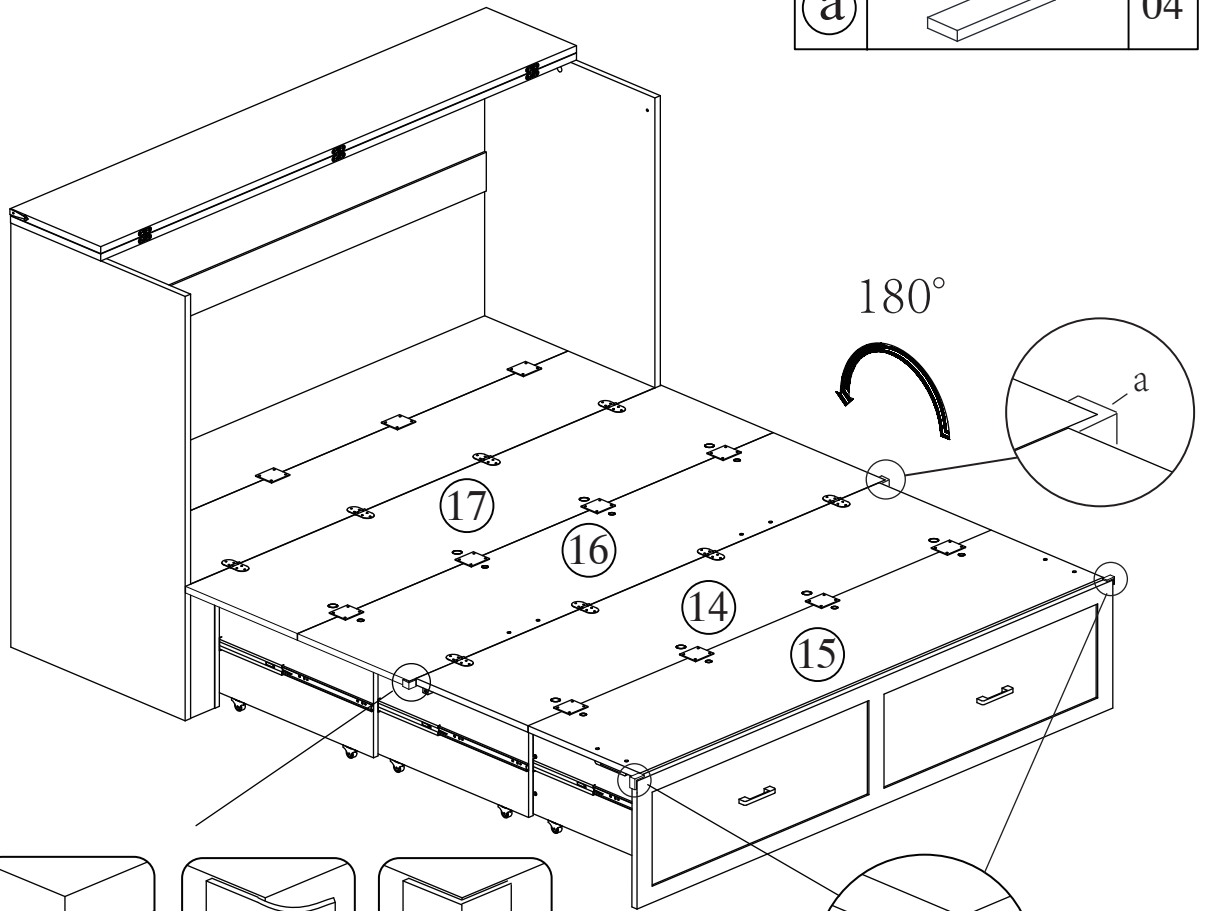

STEP 47:

Étape

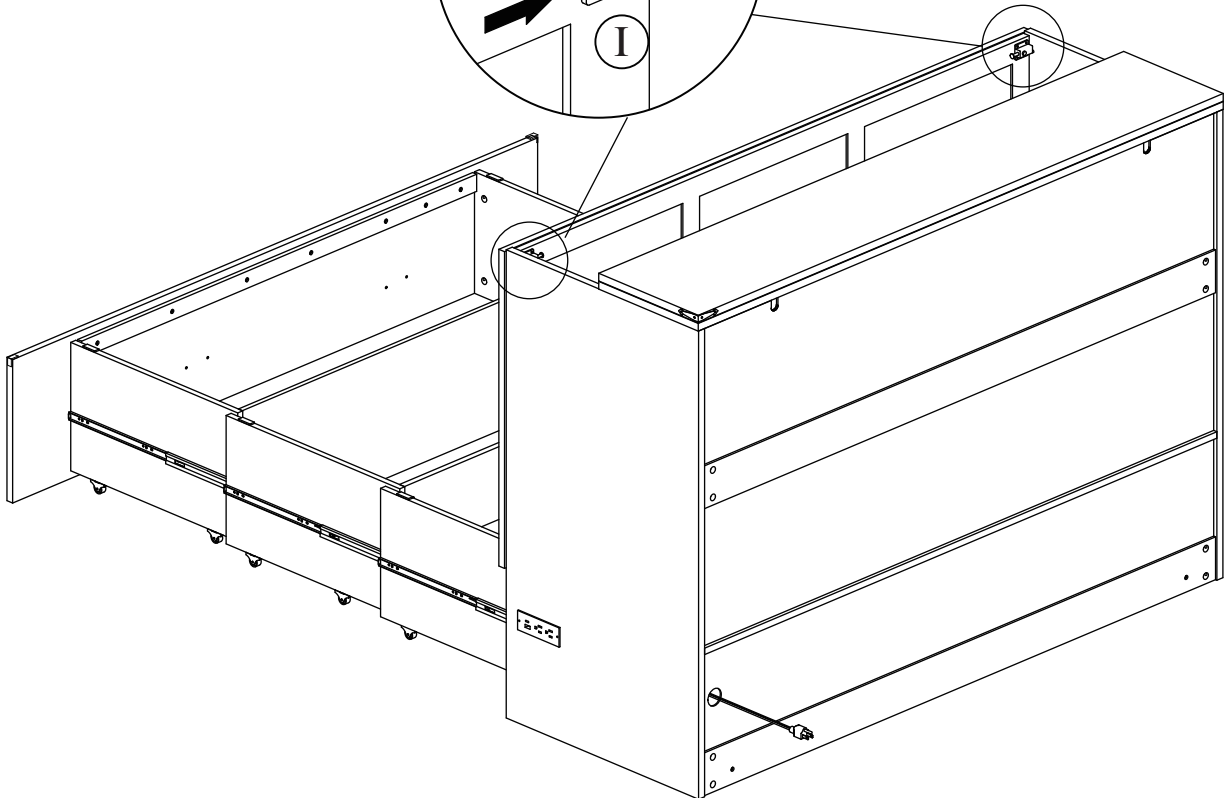
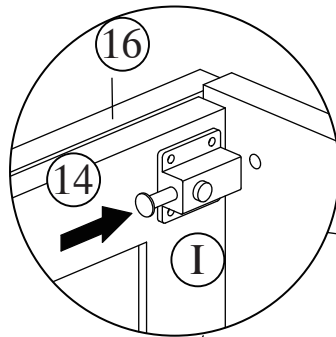
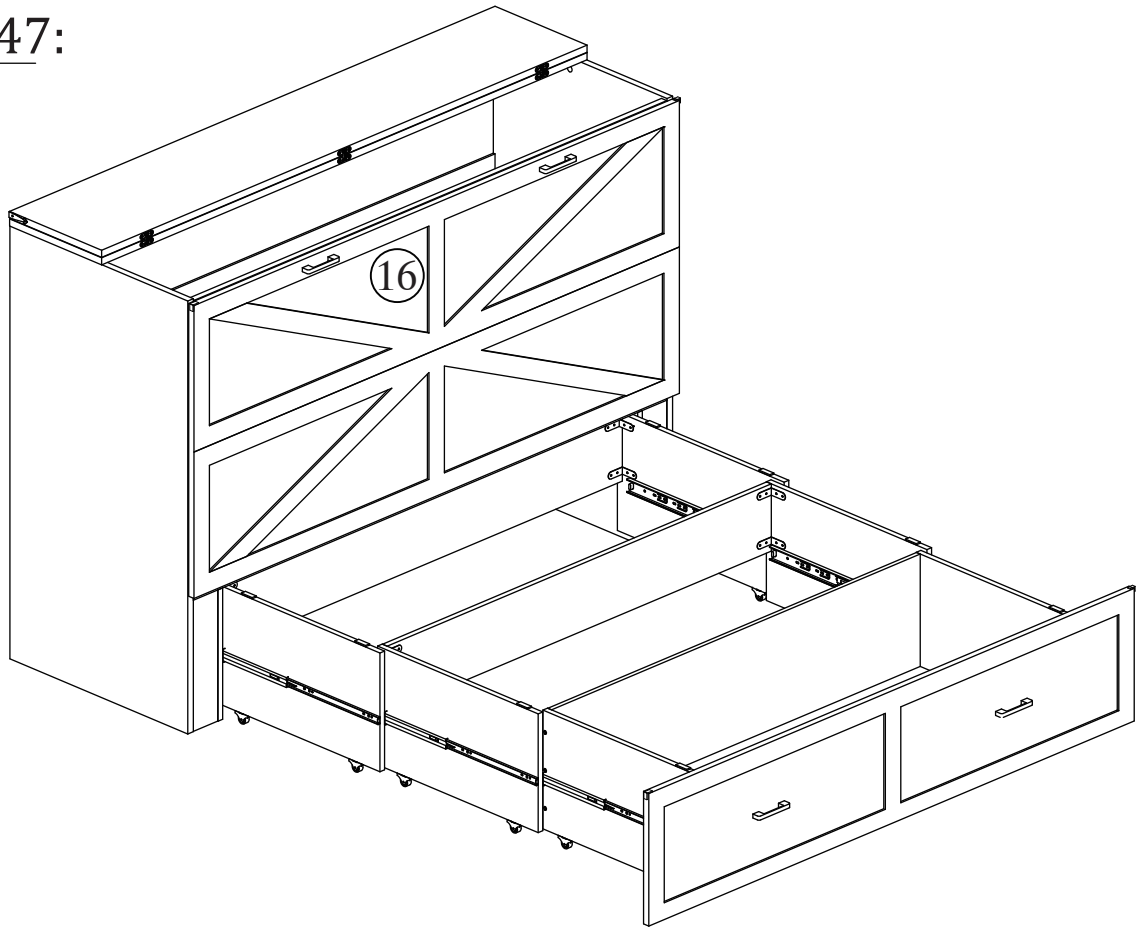

STEP 48:

Étape

180°

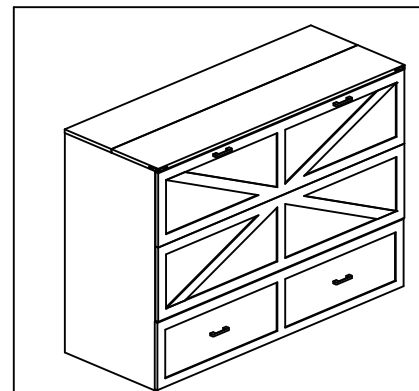
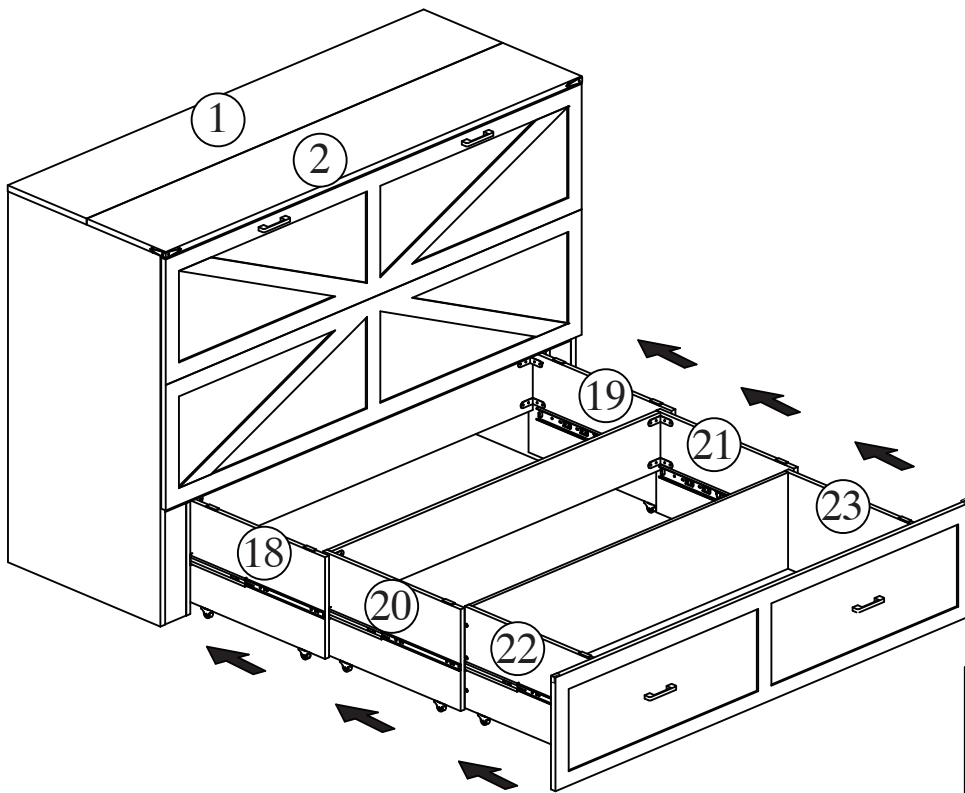
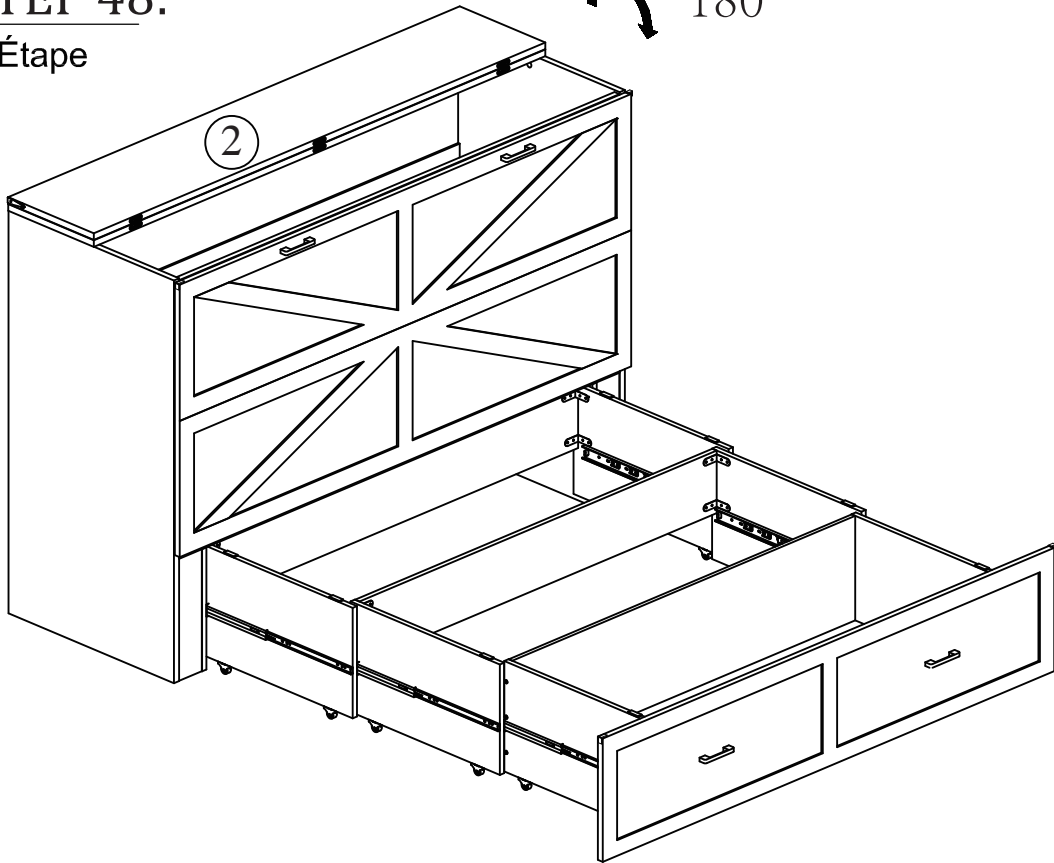

STEP 49:

Étape

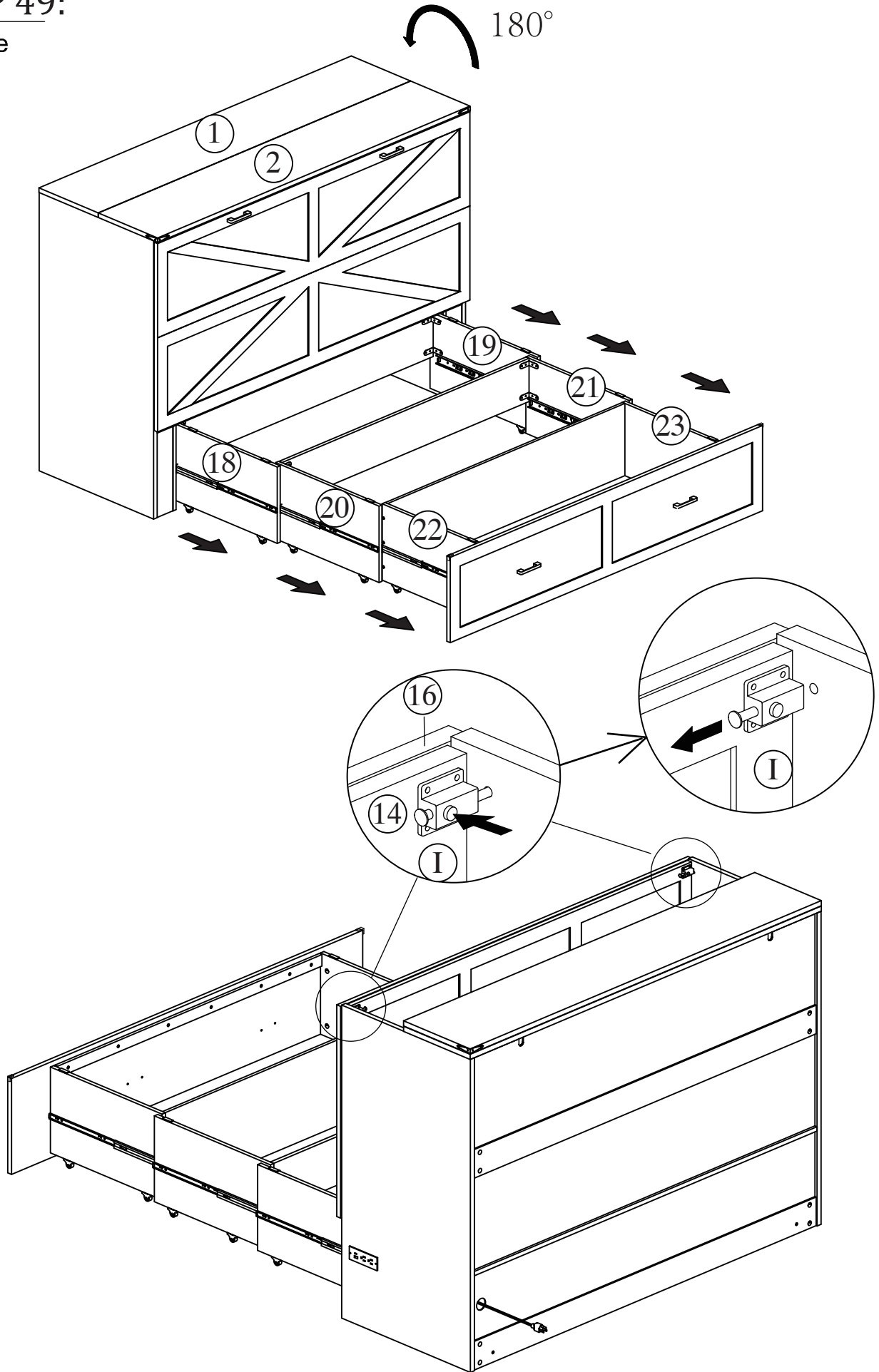

STEP 50:

Étape

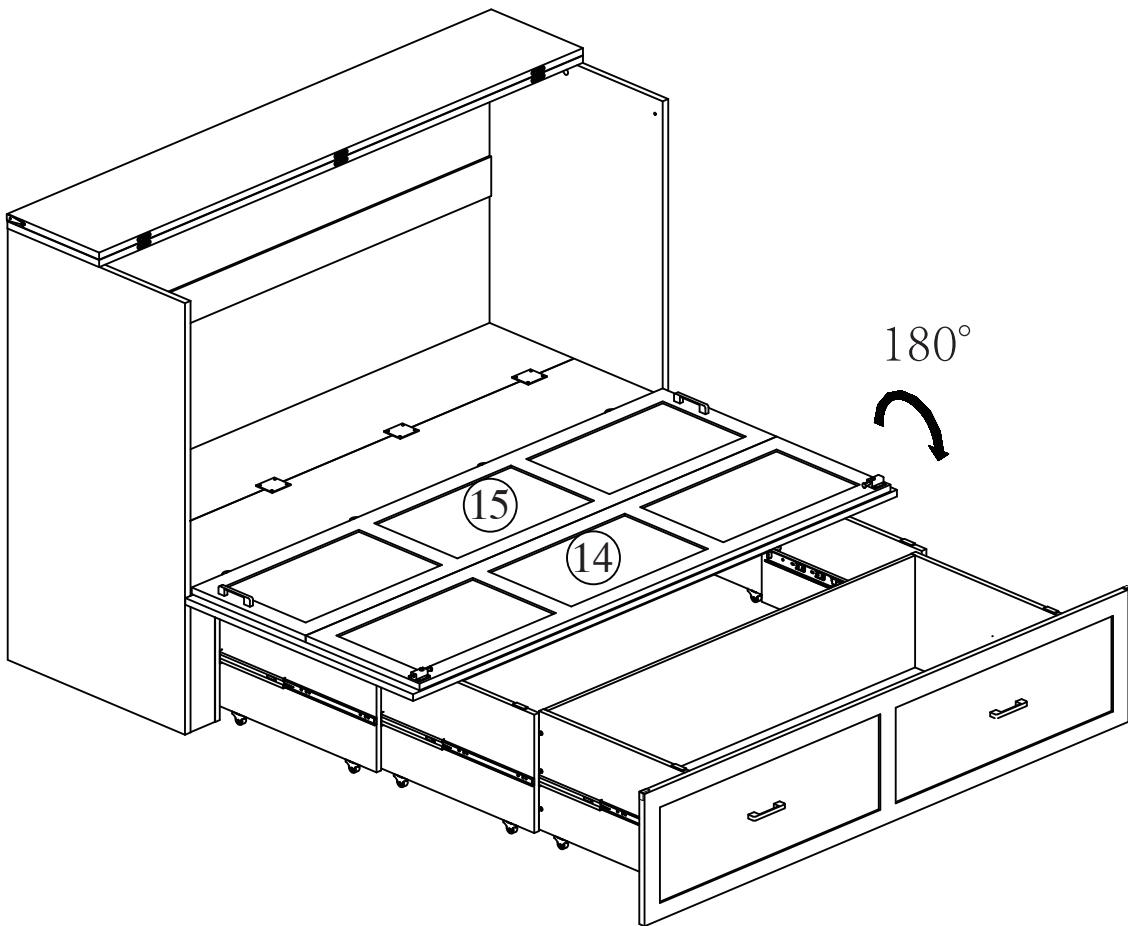
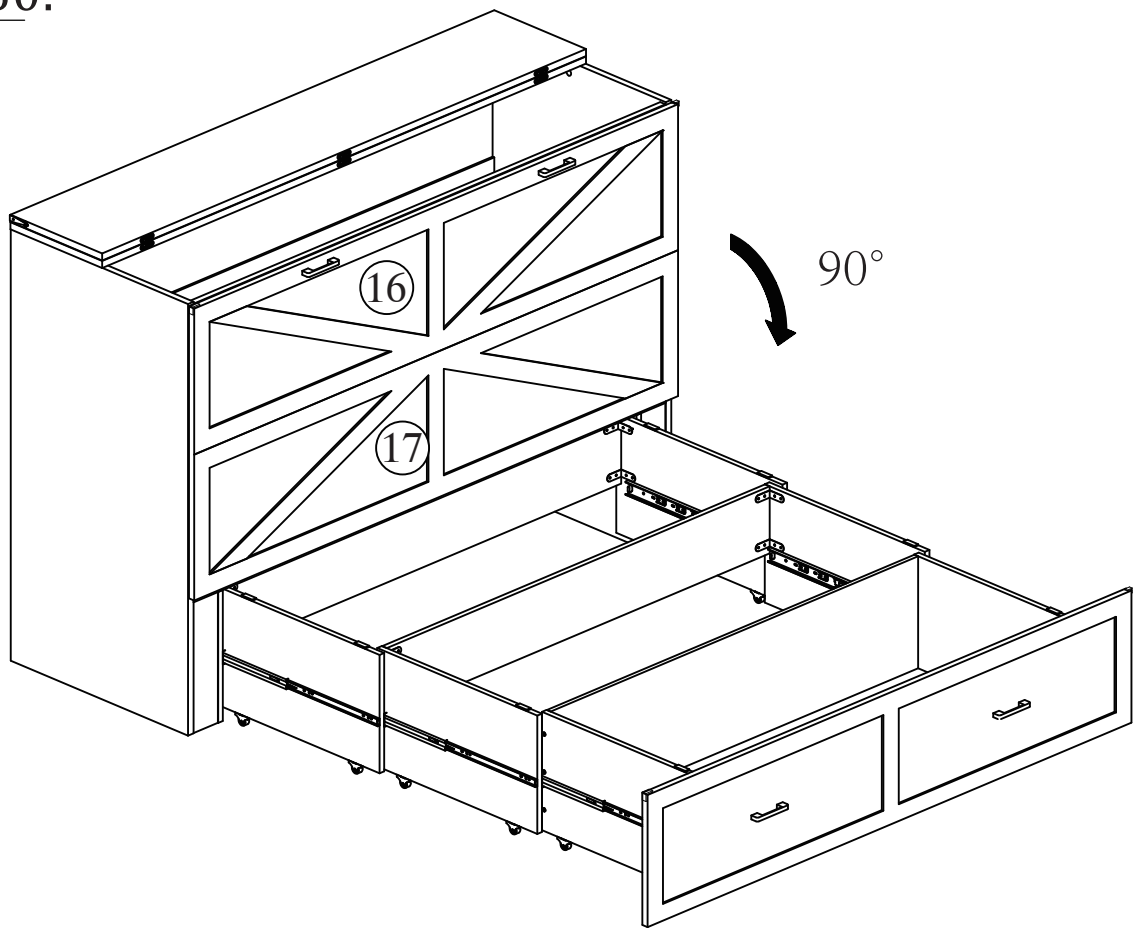

STEP 51:

Étape

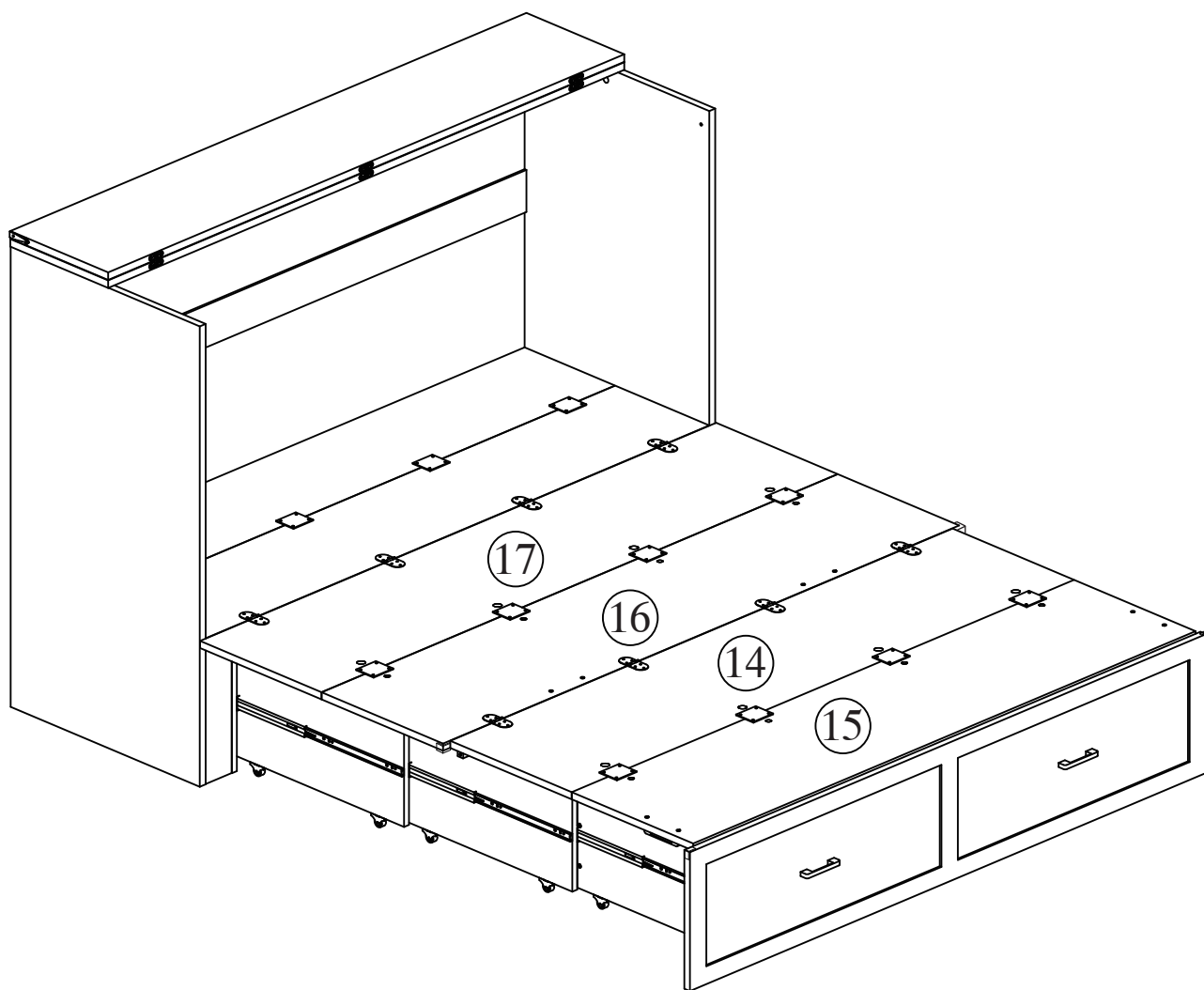

STEP 52:

Étape

