

ASSEMBLY INSTRUCTIONS



Fine Furniture for every stage of life

Dining Table

REVISION 0: 11/18/2015
REVISION 1: 08/02/2018
REVISION 2: 12/01/2017
REVISION 3: 07/13/2020

ASSEMBLY INSTRUCTIONS

ASSEMBLY TIPS :

1. Remove hardware from box and sort by size.
2. Please check to see that all hardware and parts are present prior to start of assembly.
3. Please follow attached instructions in the same sequence as numbered to assure fast & easy assembly.



WARNING !

1. Don't attempt to repair or modify parts that are broken or defective. Please contact the store immediately.
2. This product is for home use only and not intended for commercial establishments.

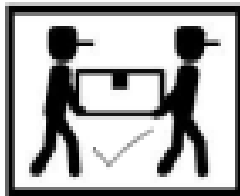

ASSEMBLY TIME

15 MINUTES

PARTS IDENTIFICATION

AN

TOP

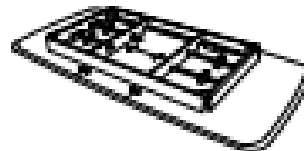

1PC

BN

LEG



4PCS

HARDWARE IDENTIFICATION

1

ALLEN WRENCH
(M5 x 65mm - BLK)



1PC

2

BOLT
(M8 x 80mm - RBW)



8PCS

3

LOCK WASHER
(5/16" - RBW)



8PCS

4

FLAT WASHER
(5/16" - RBW)



8PCS

NOTE :

Phillips head screw driver is required in the assembly process ; However, manufacturer not provide this item.

ASSEMBLY INSTRUCTIONS

STEP 1

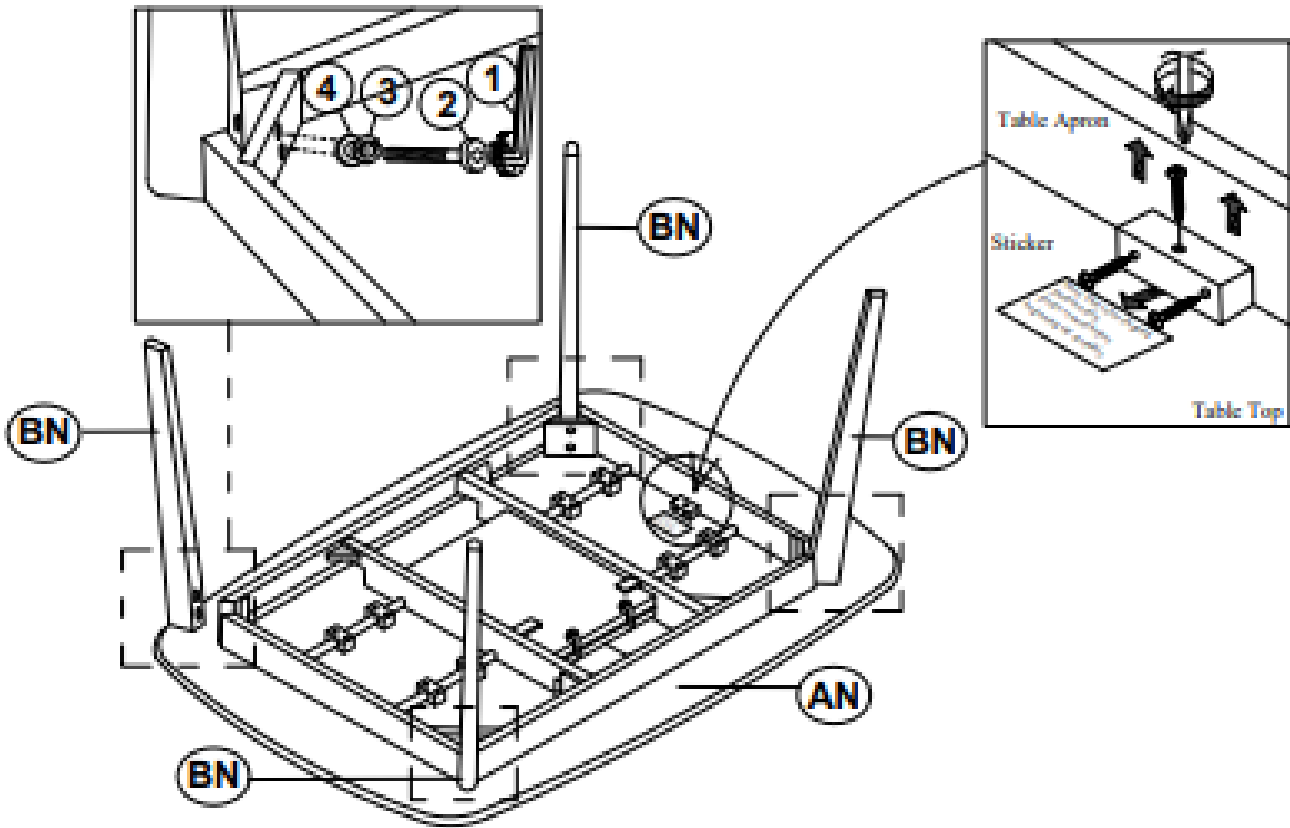

STEP 2

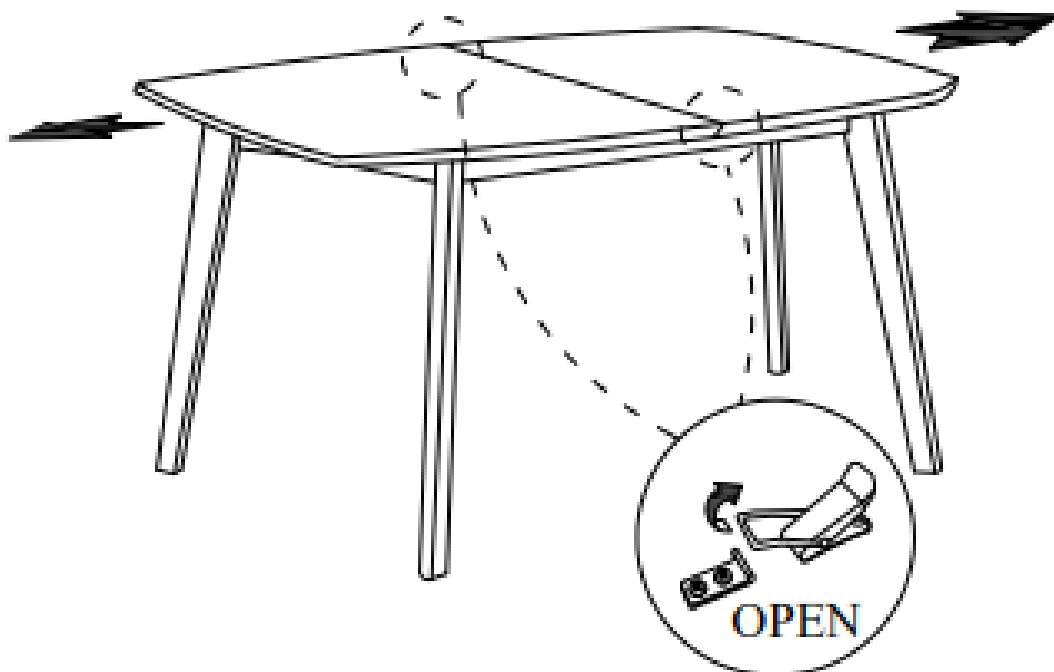

ASSEMBLY INSTRUCTIONS

STEP 3

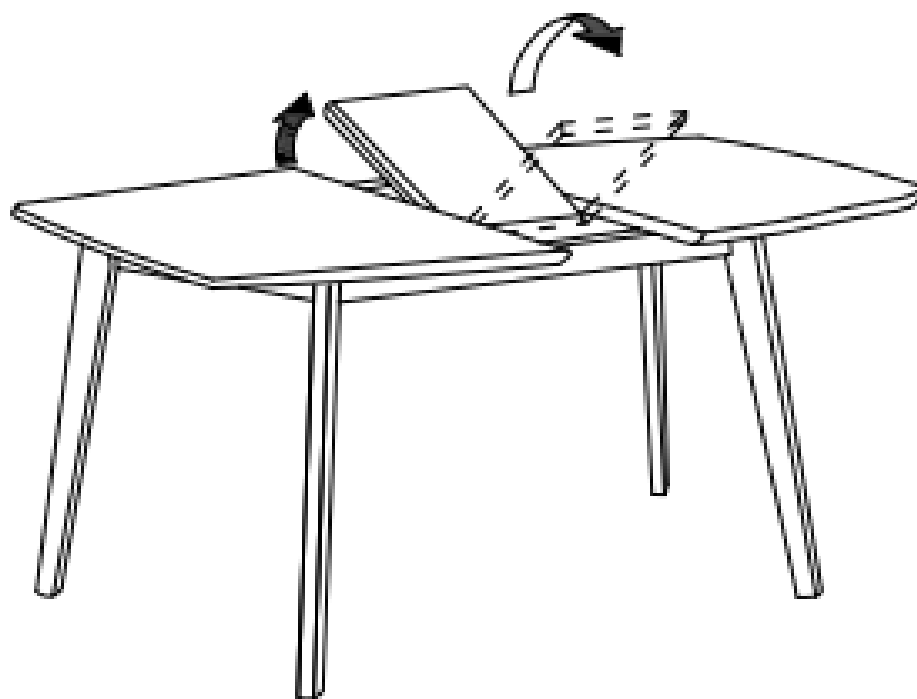

STEP 4

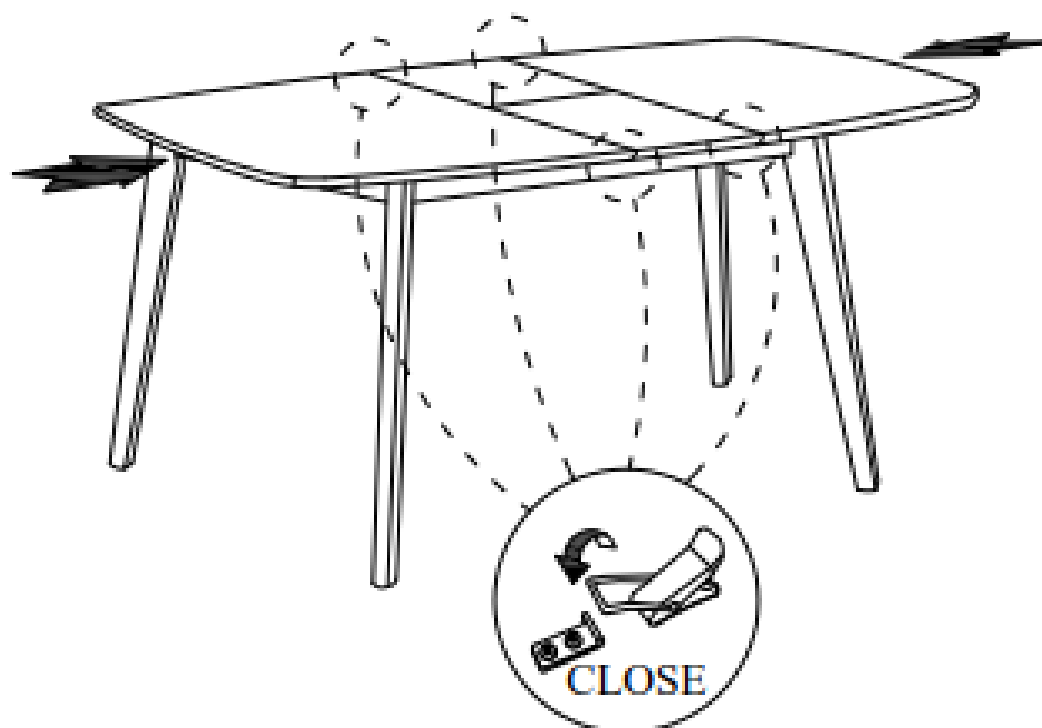

ASSEMBLY INSTRUCTIONS

STEP 5 COMPLETE

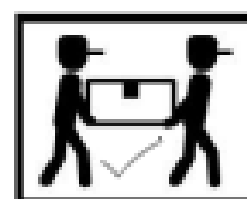
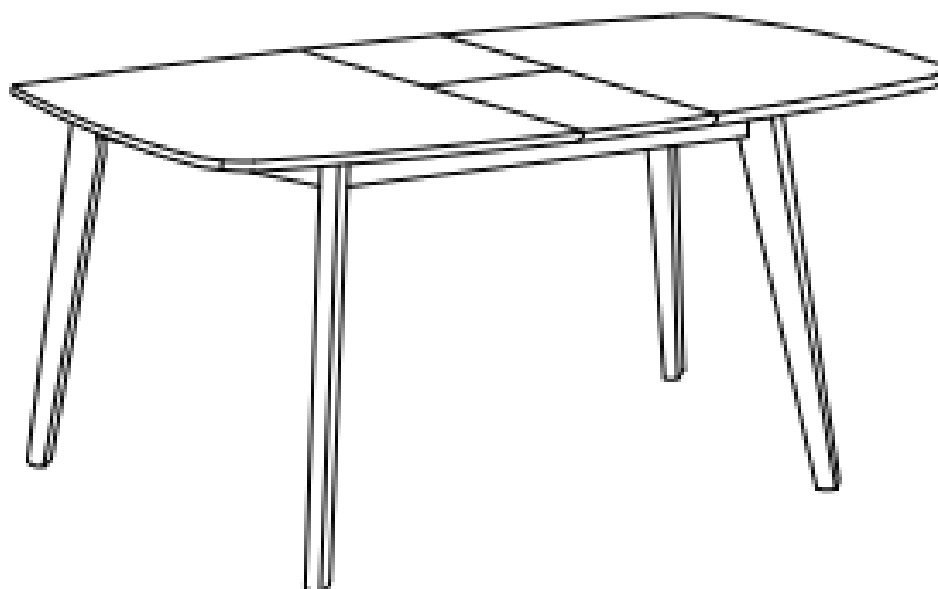

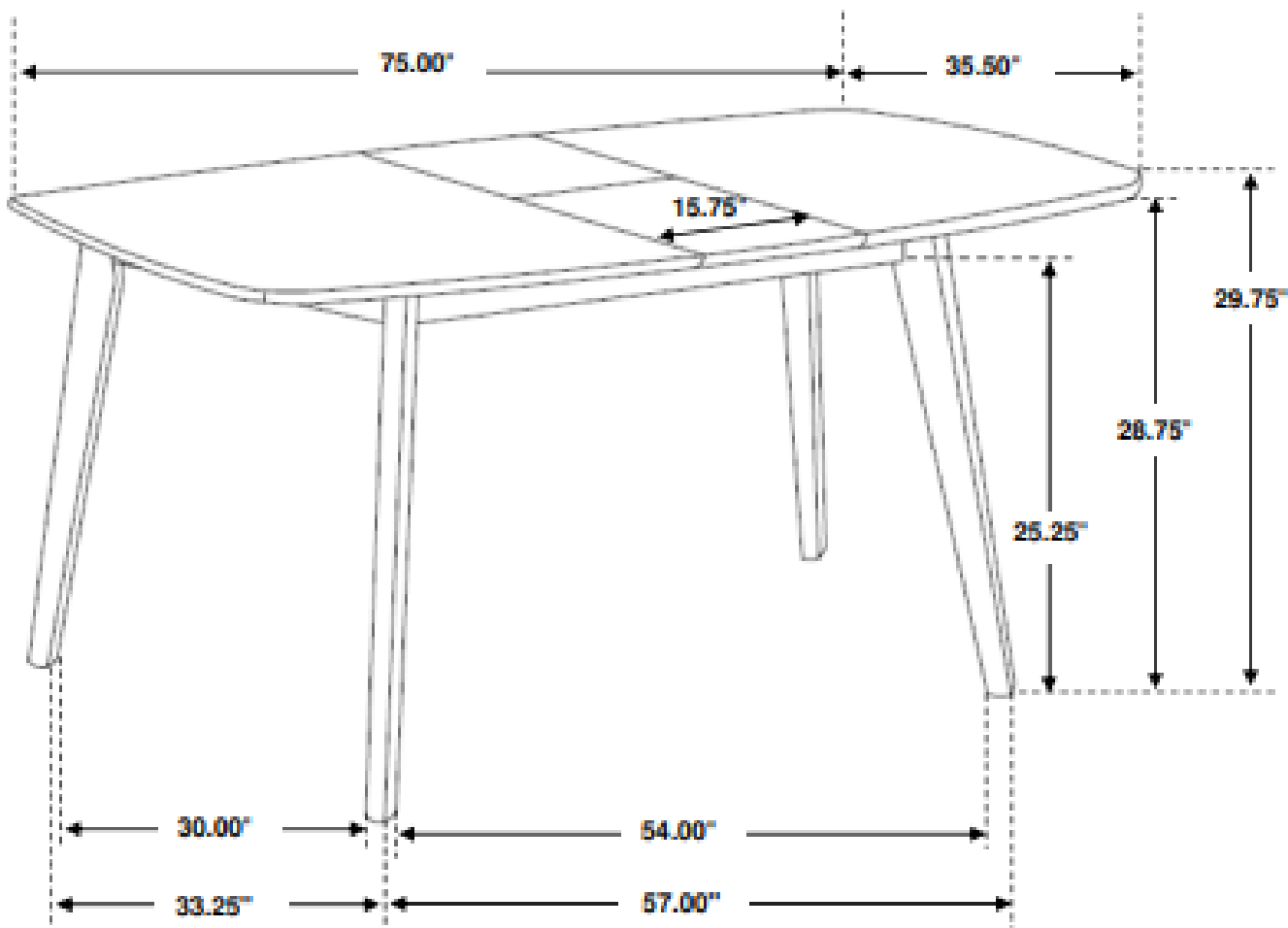

Note: Dimension tolerance $\pm 5\%$

ASSEMBLY INSTRUCTIONS



Fine Furniture for every stage of life

Dining Side Chair

REVISION 0: 11/08/2015
REVISION 1: 12/01/2017
REVISION 2: 02/25/2020

ASSEMBLY INSTRUCTIONS

ASSEMBLY TIPS :

1. Remove hardware from box and sort by size.
2. Please check to see that all hardware and parts are present prior to start of assembly.
3. Please follow attached instructions in the same sequence as numbered to assure fast & easy assembly.



WARNING !

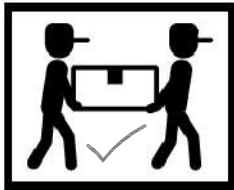

1. Don't attempt to repair or modify parts that are broken or defective. Please contact the store immediately.
2. This product is for home use only and not intended for commercial establishments.





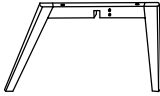
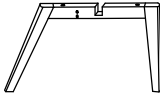
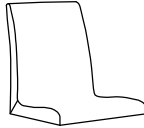

ASSEMBLY TIME

10 MINUTES

PARTS IDENTIFICATION

AN	UPPER LEG FRAME		1PC
BN	LOWER LEG FRAME		1PC
CN	SEAT AND BACK		1PC
DN	WOOD CLEAT		2PCS

HARDWARE IDENTIFICATION

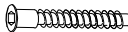
1	ALLEN WRENCH (M4 x 110mm - BLK)		1PC
2	BOLT (M6 x 70mm - RBW)		4PCS
3	LOCK WASHER (1/4" - BLK)		4PCS
4	FLAT WASHER (M6 x 13mm - RBW)		4PCS
5	PAN HEAD SCREW (M4 x 30mm-BLK)		8PCS
6	ALLEN HEAD SCREW (M7 X 50MM ZB(10#) - ZB)		1PCS

NOTE :

Phillips head screw driver is required in the assembly process. However, manufacturer does not provide this item. Quantities shown are for one chair.

ASSEMBLY INSTRUCTIONS

STEP 1

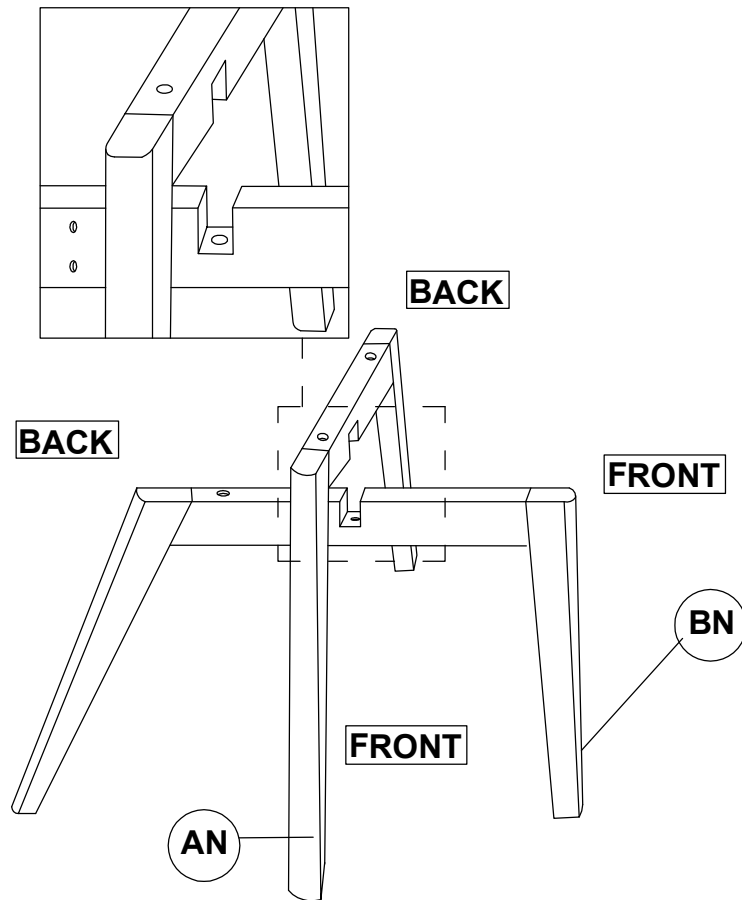

STEP 2

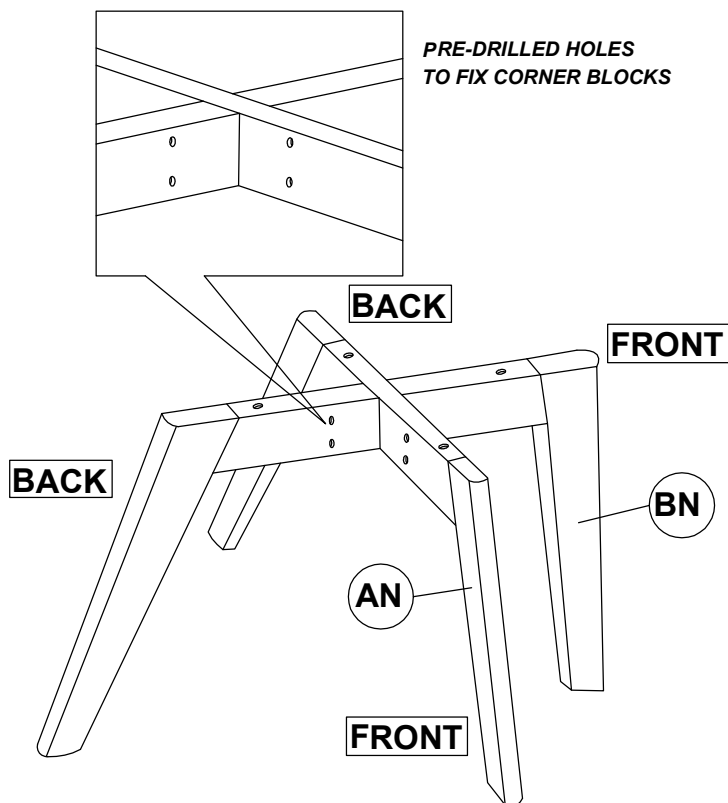

ASSEMBLY INSTRUCTIONS

STEP 3

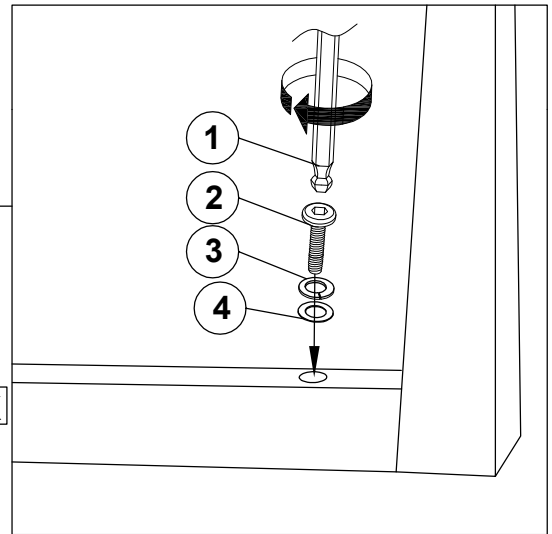
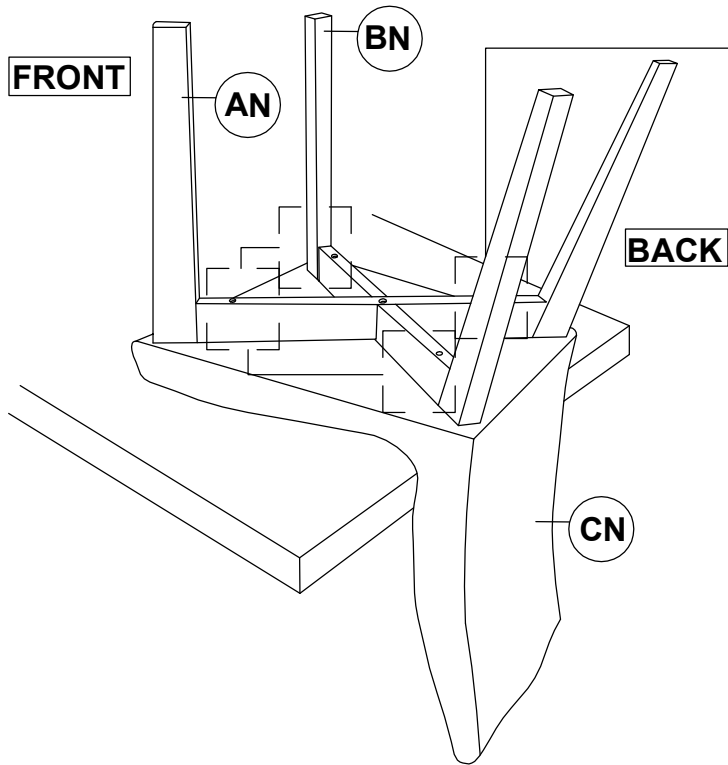

STEP 4

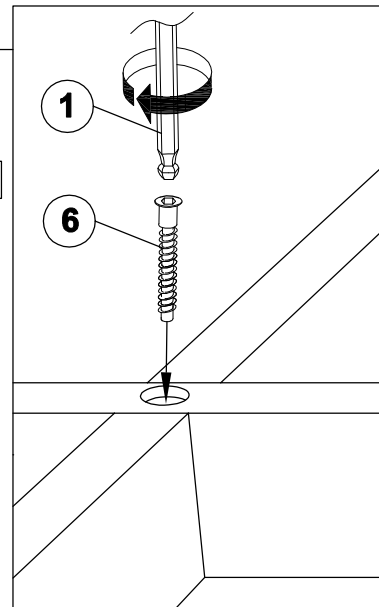
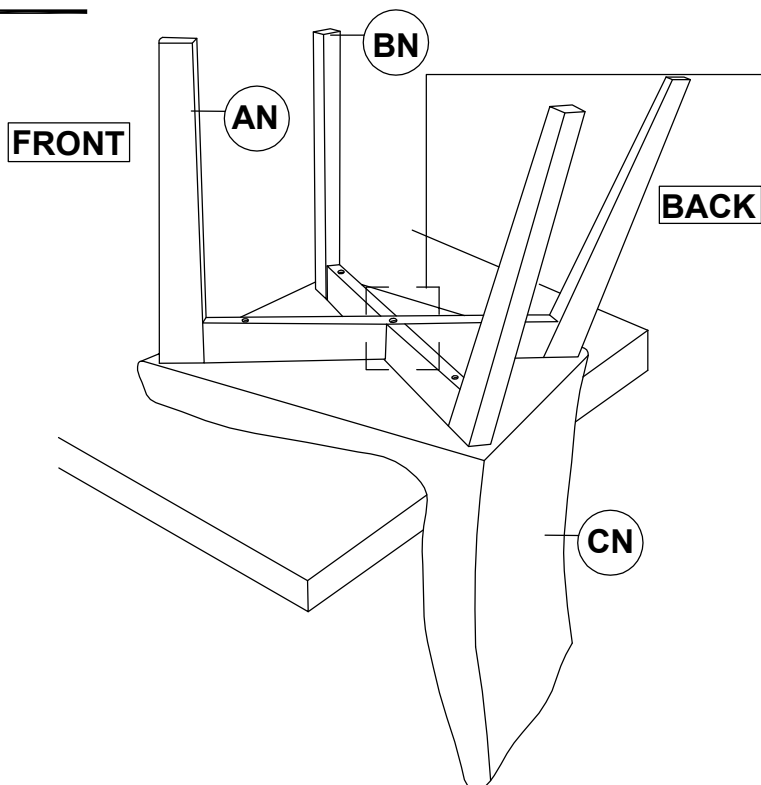

ASSEMBLY INSTRUCTIONS

STEP 5

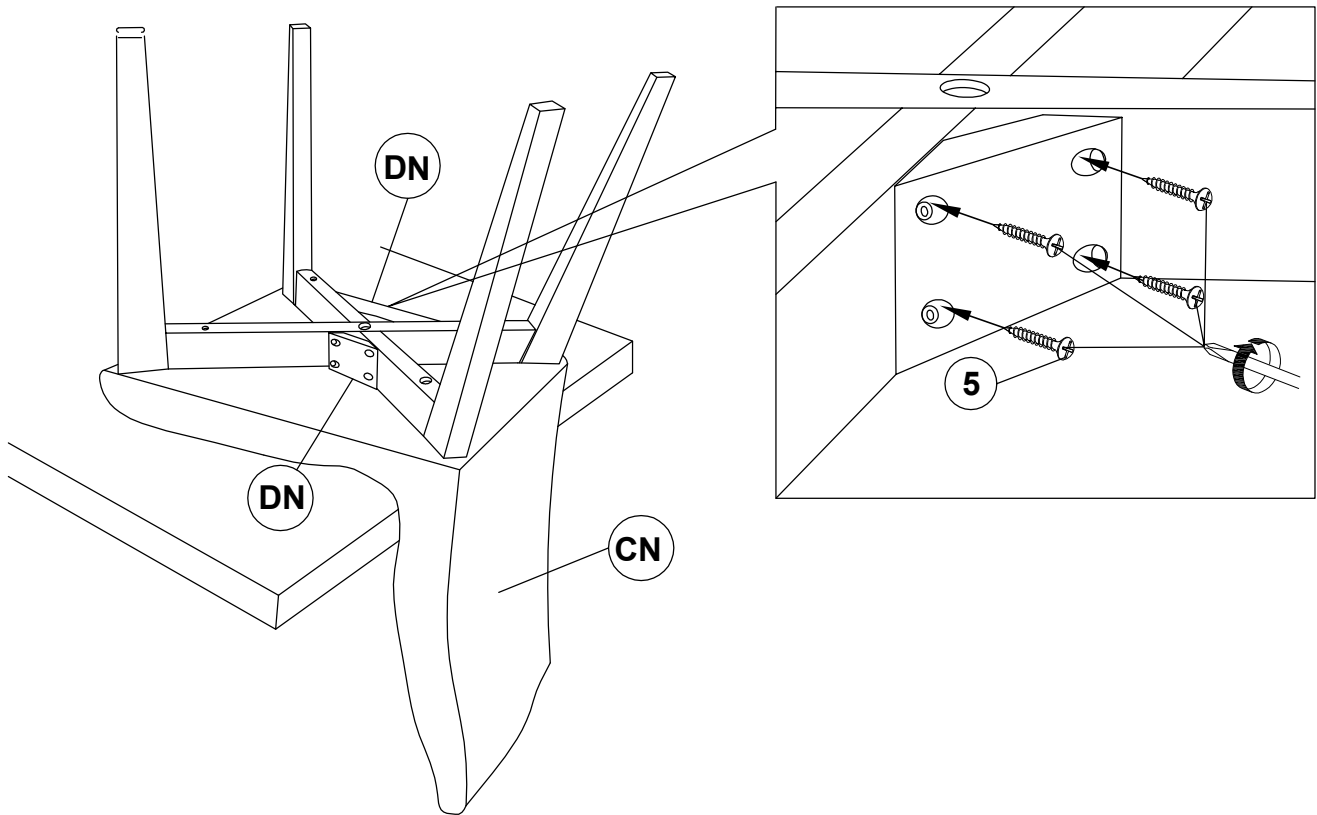

STEP 6 **COMPLETE**

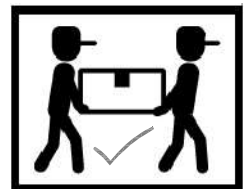
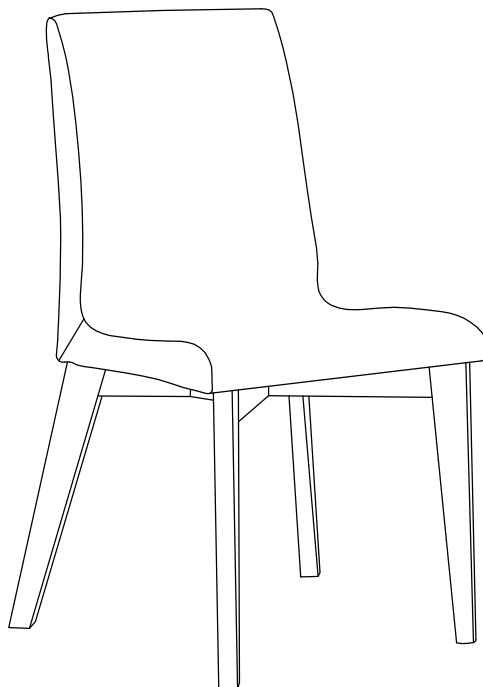

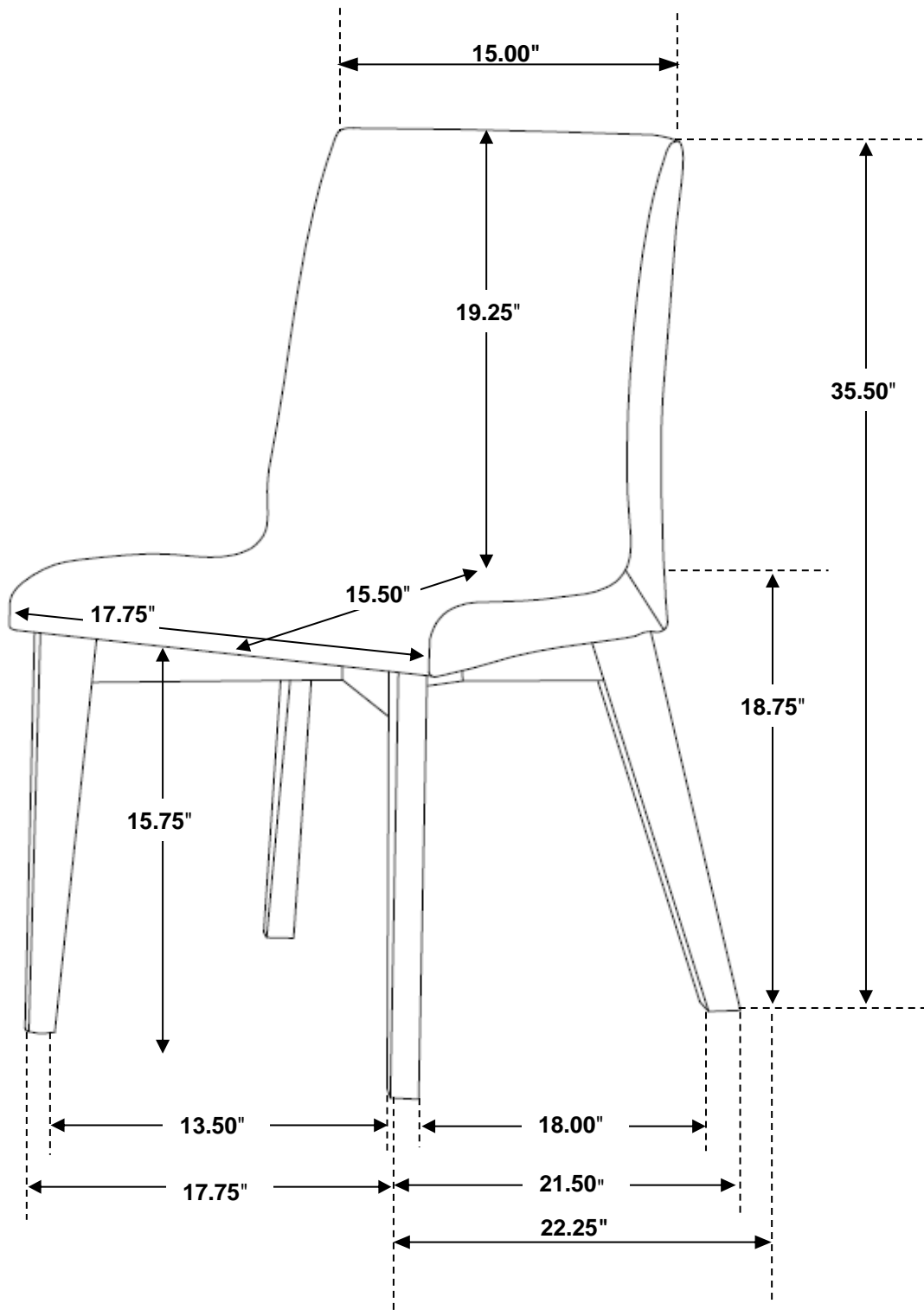

Note: Dimension tolerance $\pm 5\%$